

SITE PLAN

FAR & Tenement Details (Table 4c-1)

Building	No. of Same Bldg	Total Built Up Area (Sq.mt.)	Proposed FAR Area (Sq.mt.) Resi.	Total FAR Area (Sq.mt.)	Total Consumed Additional FAR Area (Sq.mt.)	Tnmt (No.)
A1 (RESIDENSE)	1	92.87	92.87	92.87	92.87	01
Grand Total	1	92.87	92.87	92.87	92.87	01

Proposal Basic Information

Proposal File No.	SINPC/BP/0196/W01/2020
Owner Name	TARCILA TOPPO
Khata No	192
Plot No	1671
Village Name	Gotra
Use	Residential
SubUse	Bungalow/ Dwelling / Non Apartment

AREA STATEMENT SIMDEGA NAGAR PANCHAYAT		VERSION NO. : 1.0.53	VERSION DATE: 16/10/2020
PROJECT DETAIL:			
Region: JHARKHAND URBAN LOCAL BODIES	Plot Use: Residential		
District: SIMDEGA	Plot SubUse: Bungalow/ Dwelling / Non Apartment		
Authority: SIMDEGA NAGAR PANCHAYAT	PlotNearbyReligiousStructure: NA		
Inward No: SINPC/BP/0196/W01/2020	PlotSubPlot No: 1671		
Application Type: General Proposal	North: -		
Project Type: Building Permission	South: -		
Nature of Development: New	East: -		
Location of Development Area: Old Area	West: -		
AREA DETAILS:			
AREA OF PLOT (Minimum)	(A)	SQ.MT. 401.61	
NET AREA OF PLOT(Gross Plot Area - Deduction from Gross Plot area)	(A-Deductions)	401.61	
Deduction for Balance Plot Area(from Gross Plot Area)			
Common Plot		35.52	
Total		35.52	
BALANCE AREA OF PLOT(Net Plot Area - Recreational/Amenity space)	(A-Deductions)	366.09	
PLOT AREA FOR COVERAGE(Net Plot Area)	(A-Deductions)	401.61	
Plot Area for FAR (Net Plot Area + RoadWidening Area)	(A-Deductions)	401.61	
COVERAGE CHECK			
Permissible Coverage area ( 60.00 % )		240.97	
Proposed Coverage Area ( 23.12 % )		92.87	
Total Prop. Coverage Area ( 23.12 % )		92.87	
Balance coverage area ( 36.88 % )		148.10	
FAR CHECK			
Perm. FAR Area ( 1.50 )		602.41	
Total Perm. FAR area		602.41	
Residential FAR		92.87	
Proposed FAR Area		92.87	
Total Proposed FAR Area		92.87	
Consumed FAR (Factor)		0.23	
Balance FAR Area		509.54	
BUILT UP AREA CHECK			
Total Proposed BuiltUp Area		92.87	
ARCHITECT (Regd)		RAM RATAN SINGH	
ENGINEER (Regd)			
SUPERVISOR (Regd)			
OWNER (Regd)		TARCILA TOPPO	
DEVELOPMENT AUTHORITY		LOCAL BODY	

COLOR INDEX	
PLOT BOUNDARY	Black
ABUTTING ROAD	Green
PROPOSED CONSTRUCTION	Red
COMMON PLOT	Yellow
ROAD WIDENING AREA	Blue
EXISTING (To be retained)	Orange
EXISTING (To be demolished)	Light Blue

Buildingwise Floor FAR Details

Floor Name	Building Name A1 (RESIDENSE)		Total	
	Proposed Built Up Area (Sq.mt.)	Proposed FAR Area (Sq.mt.)	Total Proposed Built Up Area (Sq.mt.)	Total FAR Area (Sq.mt.)
Ground Floor	92.87	92.87	92.87	92.87
Terrace Floor	0.00	0.00	0.00	0.00
Total	92.87	92.87	92.87	92.87

Building USE/SUBUSE Details

Building Name	Building Use	Building SubUse	Building Structure
A1 (RESIDENSE)	Residential	Residential Bldg/Apartment	Non-Highrise

LTP NAME AND SIGNATURE	STRUCTURAL ENG'S NAME AND SIGNATURE	BUILDER NAME AND SIGNATURE	DIGITAL SIGNATURE
RAM RATAN SINGH SINPC/DFTMN/0003/2020			

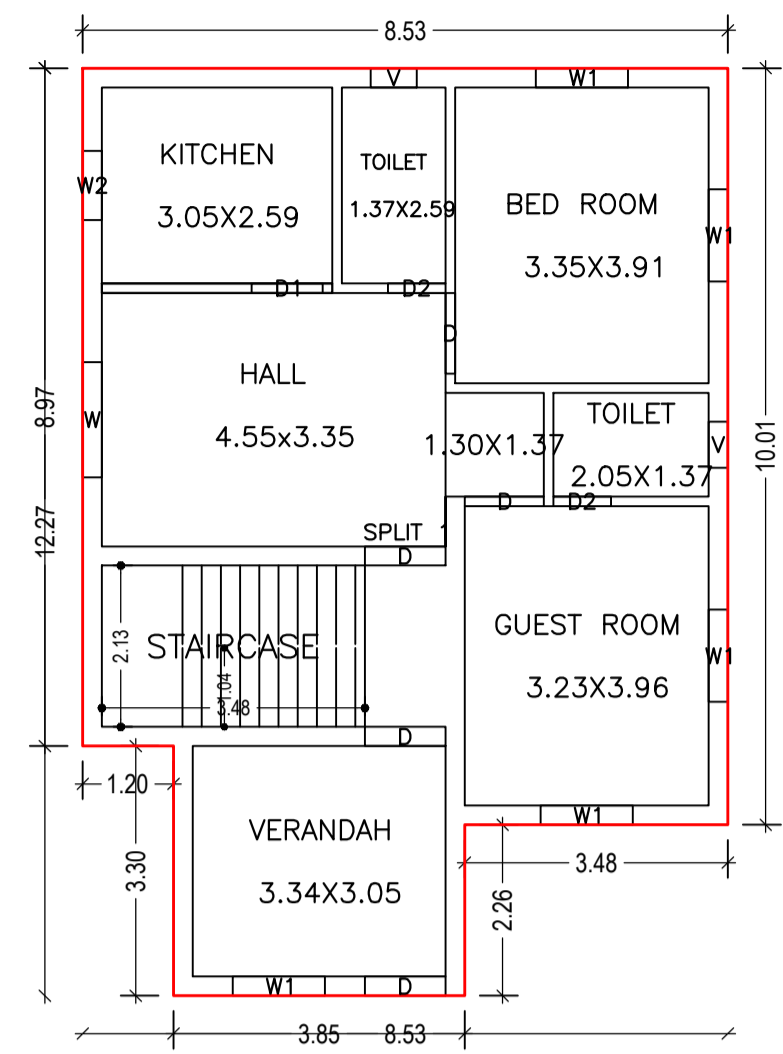

GROUND FLOOR PLAN (Proposed) SCALE 1:100

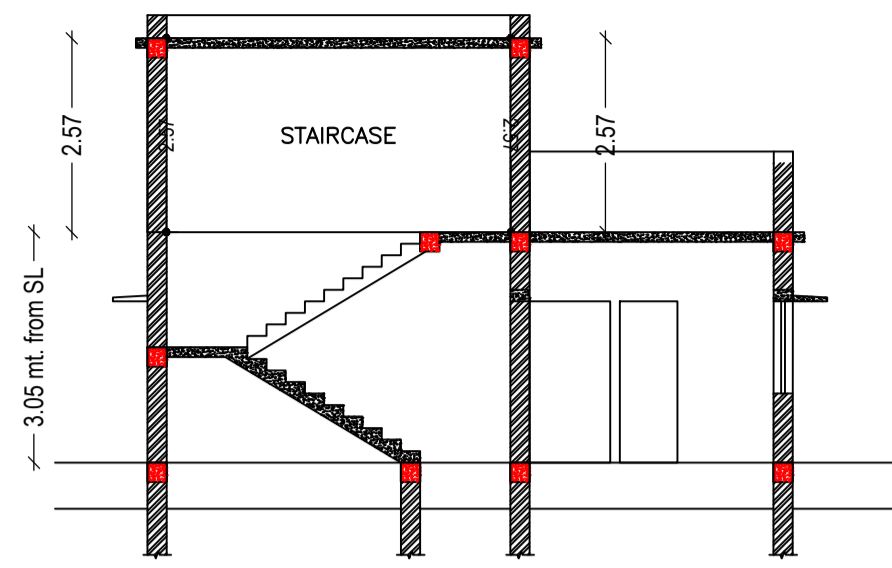

SECTION AT-X-X SCALE 1:100

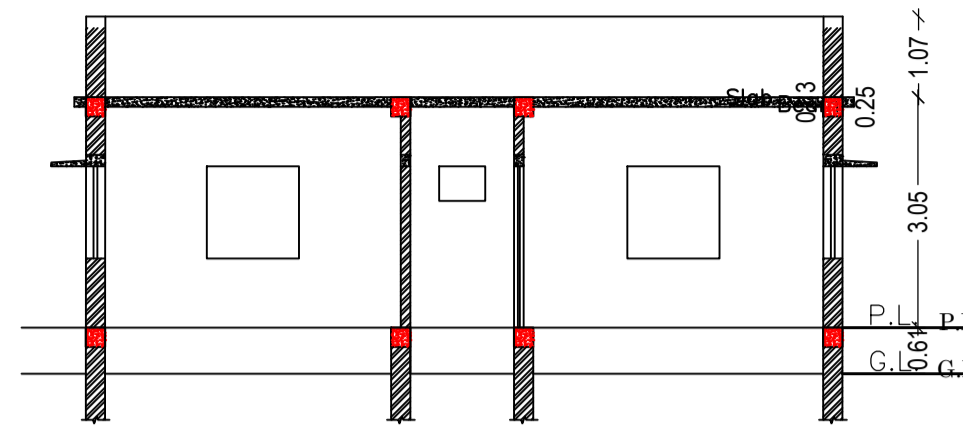

SECTION AT-Y-Y SCALE 1:100

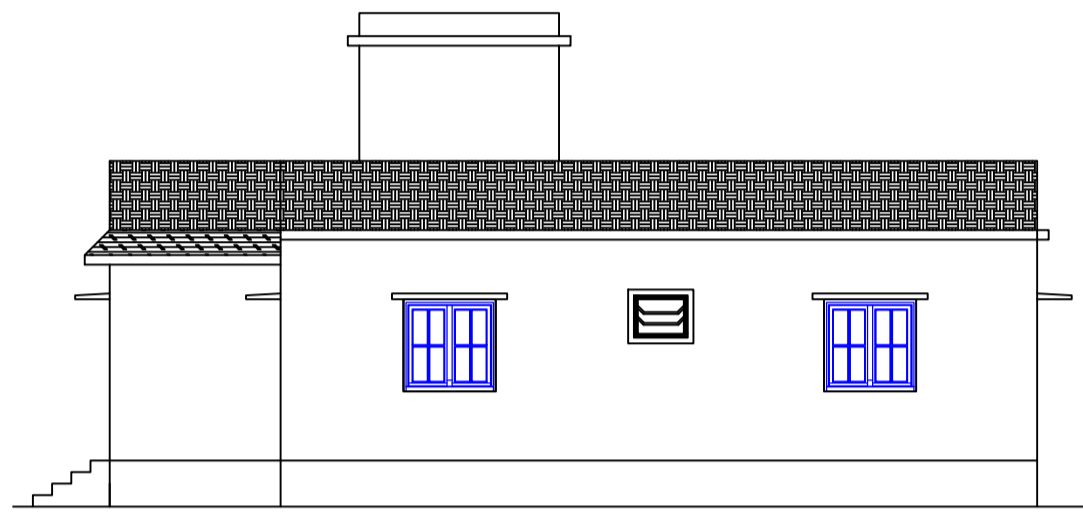

RIGHT SIDE ELEVATION SCALE 1:100



FRONT ELEVATION SCALE 1:100

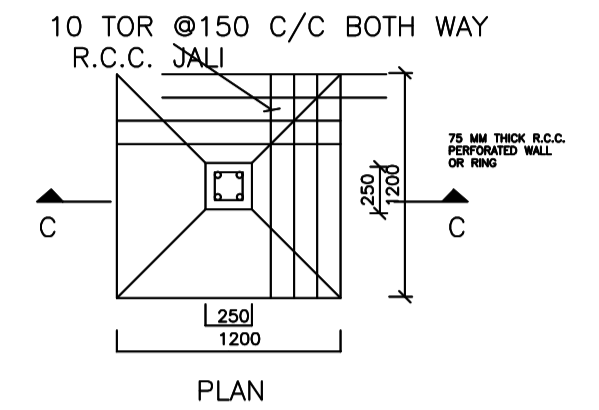

DETAIL OF FOUNDATION SCALE:-

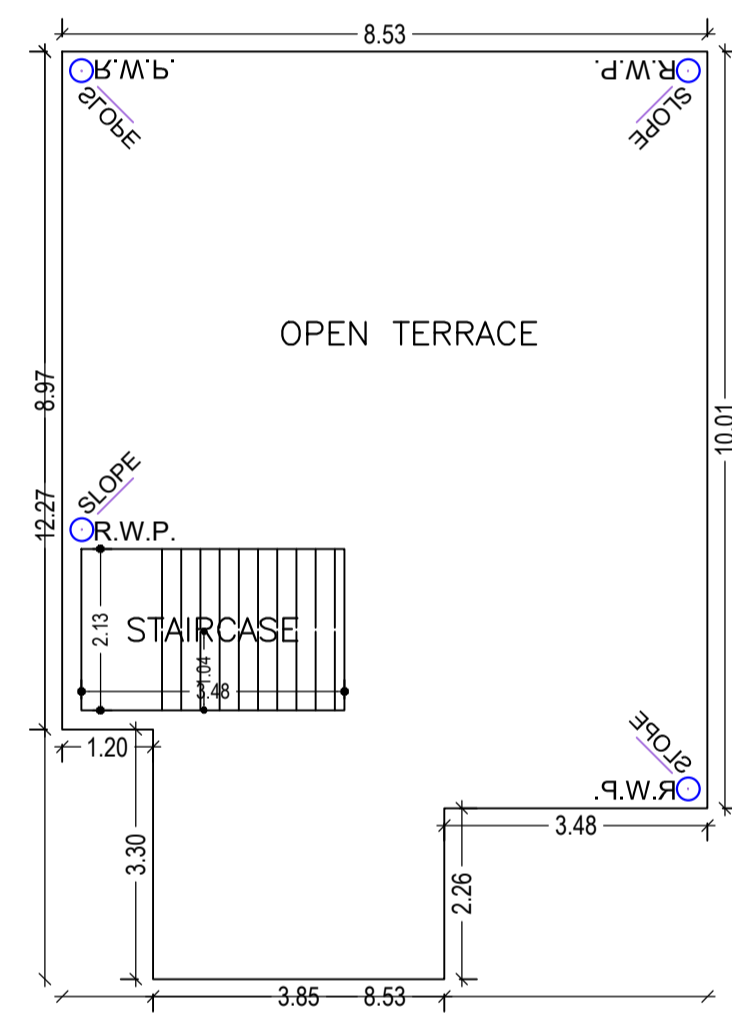
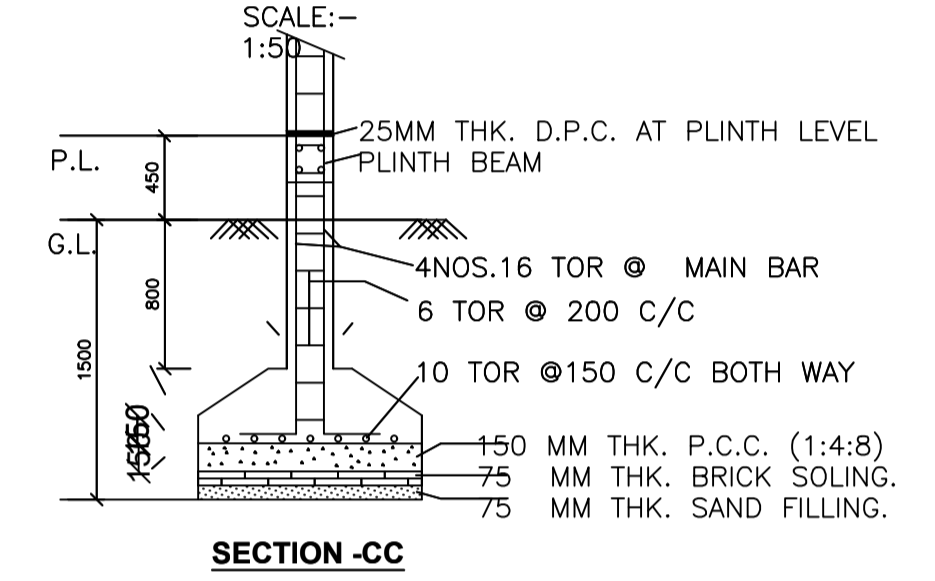

TERRACE FLOOR PLAN (SCALE 1:100)

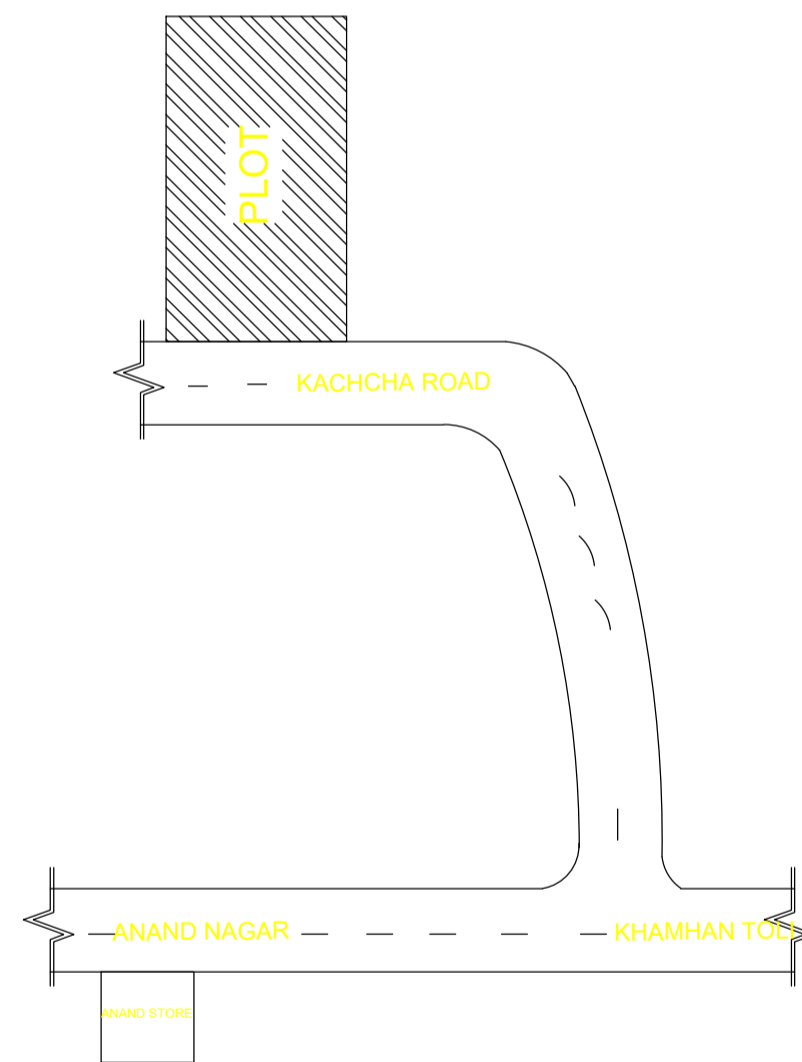

LOCATION PLAN NOT TO SCALE

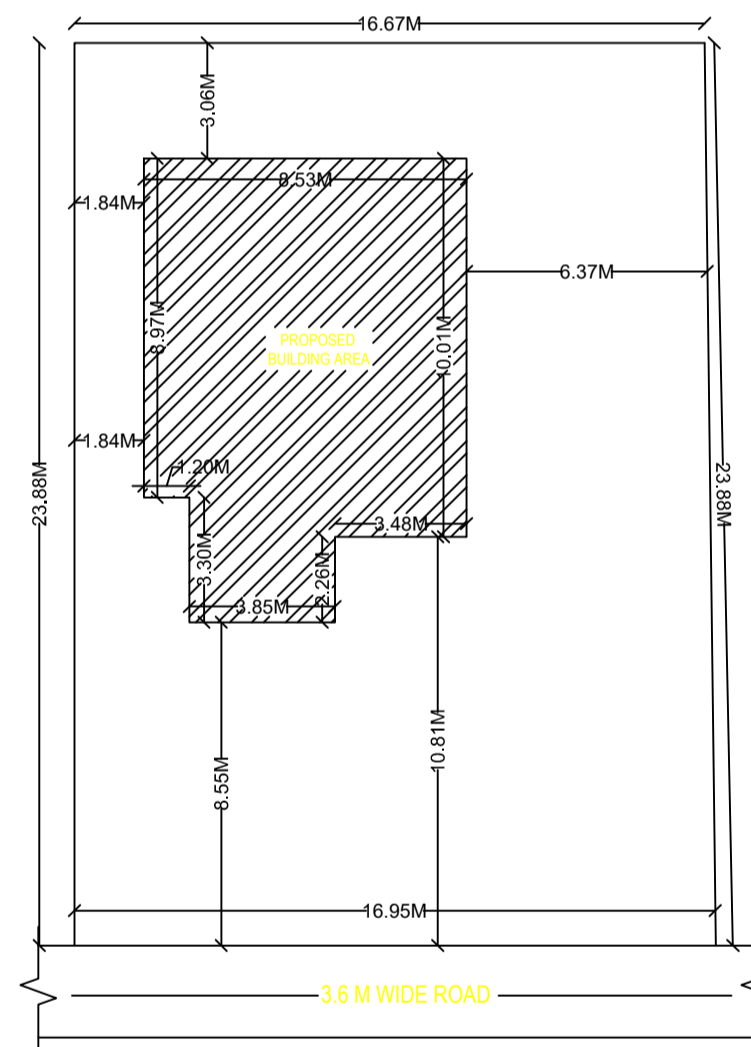

KEY PLAN SCALE 1:200

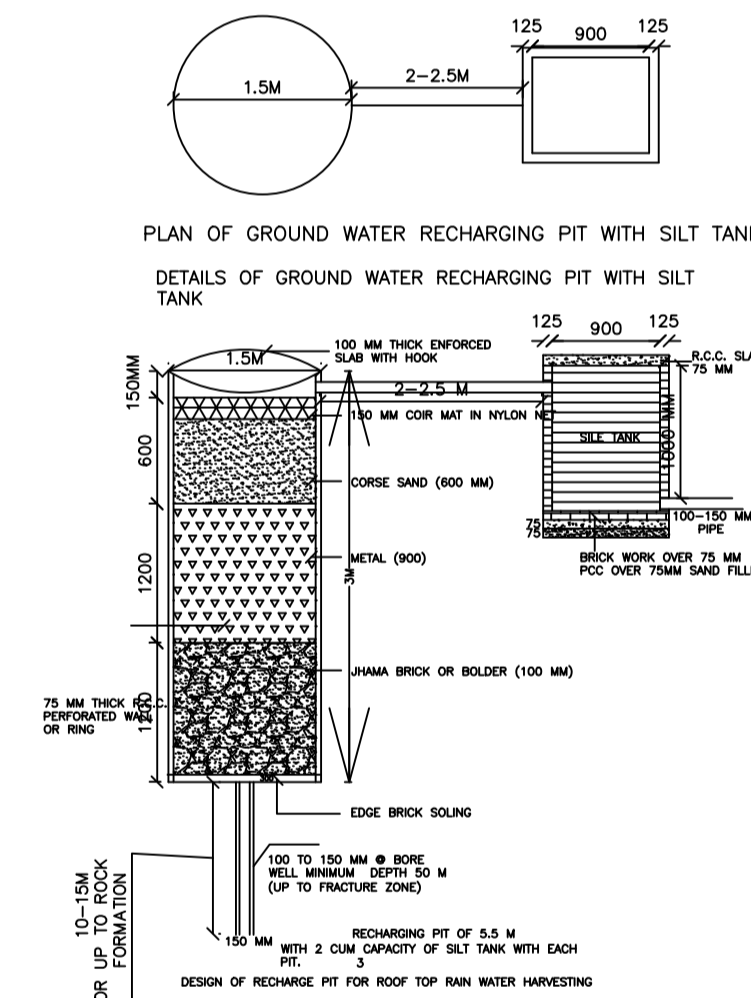

PLAN OF GROUND WATER RECHARGING PIT WITH SILT TANK

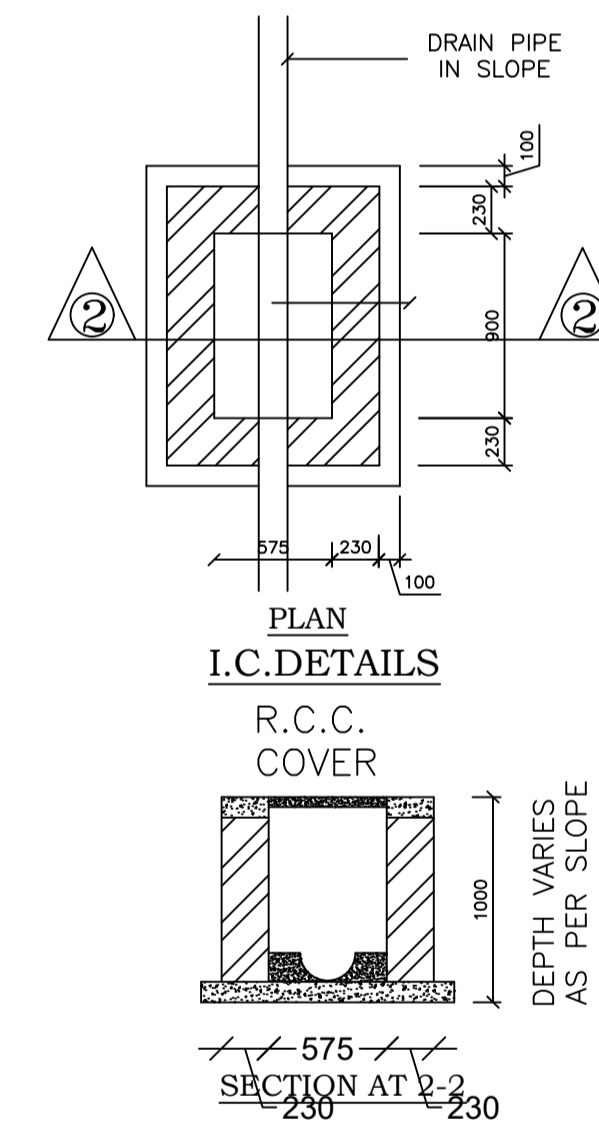

PLAN I.C. DETAILS R.C.C. COVER

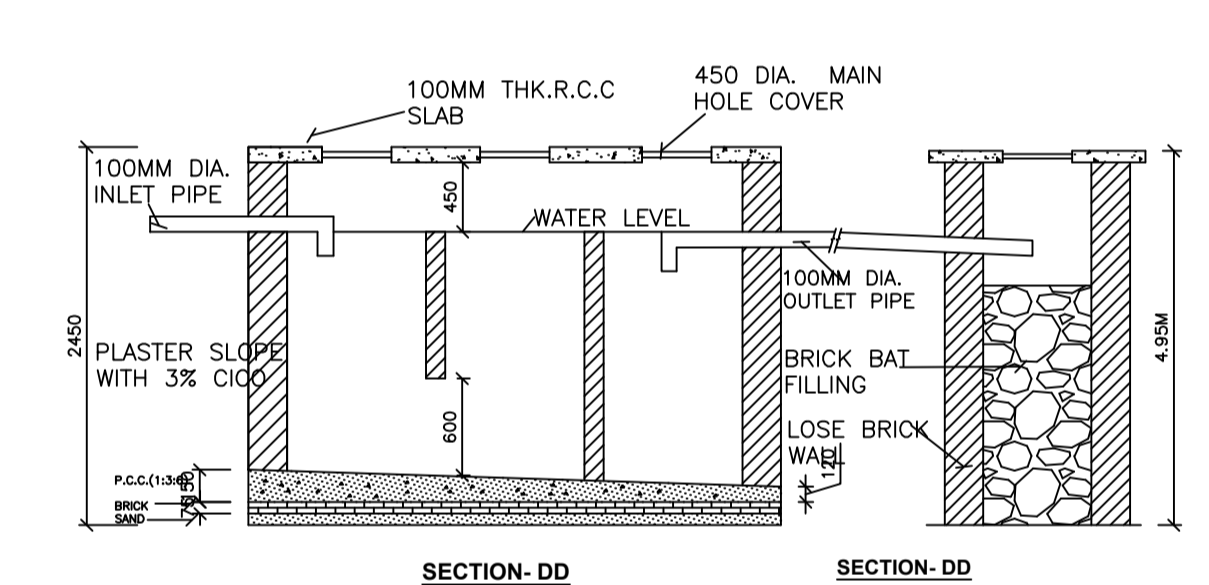

SECTION -DD

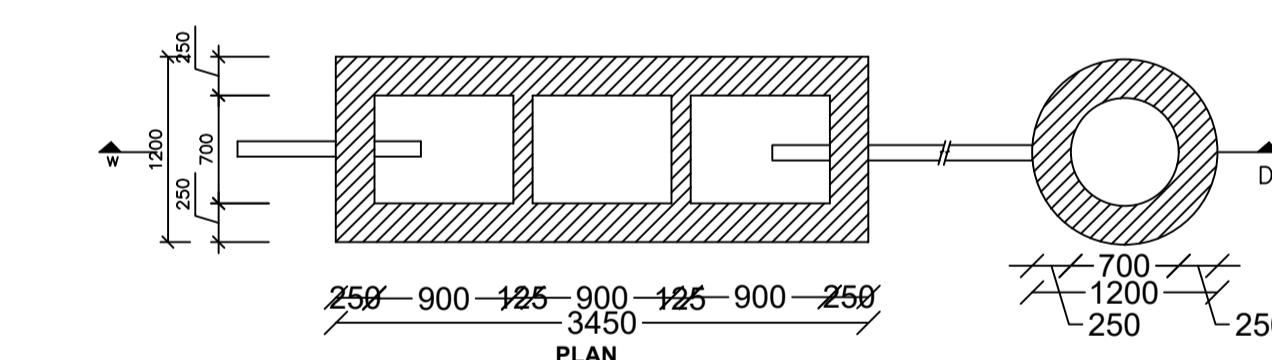

DETAIL OF SEPTIC TANK & SOAKPIT. PLAN SCALE - 1:50

SCHEDULE OF DOOR:

BUILDING NAME	NAME	LENGTH	HEIGHT	NOS
A1 (RESIDENSE)	D2	0.76	2.10	02
A1 (RESIDENSE)	D1	0.94	2.10	01
A1 (RESIDENSE)	D	1.05	2.10	01
A1 (RESIDENSE)	D	1.07	2.10	04

SCHEDULE OF WINDOW/VENTILATION:

BUILDING NAME	NAME	LENGTH	HEIGHT	NOS
A1 (RESIDENSE)	V	0.61	1.20	02
A1 (RESIDENSE)	W2	0.91	1.20	01
A1 (RESIDENSE)	W1	1.22	1.20	05
A1 (RESIDENSE)	W	1.52	1.20	01

UnitBUA Table for Building :A1 (RESIDENSE)

FLOOR	Name	UnitBUA Type	UnitBUA Area	Carpet Area	No. of Rooms	No. of Tenement
GROUND FLOOR PLAN	SPLIT 1	FLAT	70.18	69.79	7	1
Total:	-	-	70.18	69.79	7	1

Building :A1 (RESIDENSE)

Floor Name	Total Built Up Area (Sq.mt.)	Proposed FAR Area (Sq.mt.)	Total FAR Area (Sq.mt.)	Total Consumed Additional FAR Area (Sq.mt.)	Tnmt (No.)
Ground Floor	92.87	92.87	92.87	92.87	01
Terrace Floor	0.00	0.00	0.00	0.00	00
Total:	92.87	92.87	92.87	92.87	01
Total Number of Same Buildings	1				
Total:	92.87	92.87	92.87	92.87	01

LTP NAME AND SIGNATURE	STRUCTURAL ENG'S NAME AND SIGNATURE	BUILDER NAME AND SIGNATURE	DIGITAL SIGNATURE
RAM RATAN SINGH SINPC/DFTMN/0003/2020			