

SITE PLAN

FAR & Tenement Details (Table 4c-1)

Building	No. of Same Bldg	Total Built Up Area (Sq.mt.)	Proposed FAR Area (Sq.mt.) Resi.	Total FAR Area (Sq.mt.)	Total Consumed Additional FAR Area (Sq.mt.)	Tnmt (No.)
A1 (RESIDENCE)	1	215.38	215.38	215.38	215.38	02
Grand Total	1	215.38	215.38	215.38	215.38	02

Proposal Basic Information

Proposal File No.	SINPC/BP/0159/W02/2020
Owner Name	LACHHENDRA SAHU
Khata No	103
Plot No	2530
Village Name	Gotra
Use	Residential
SubUse	Bungalow/ Dwelling / Non Apartment

Required Parking (Table 7a)

Building Name	Type	SubUse	Area (Sq.mt.)	Units		Car		Visitors Car			
				Reqd.	Prop.	Reqd./Unit	Reqd.	Prop.	Reqd./Unit	Reqd.	Prop.
A1 (RESIDENCE)	Residential	Bungalow/ Dwelling / Non Apartment	>0	1	2.00	1	2	-	-	-	-
			>0	1	2.00	-	-	-	1	1	-
Total			-	-	-	-	2	3	-	1	1

Parking Check (Table 7b)

Vehicle Type	Reqd.		Prop.	
	No.	Area	No.	Area
Car	-	-	3	65.47
Total Car	2	25.00	3	65.47
Visitor's Car Parking	-	-	1	22.35
Total Visitor Parking	1	12.50	1	22.35
Total		37.50		110.17

AREA STATEMENT SIMDEGA NAGAR PANCHAYAT

Region: JHARKHAND URBAN LOCAL BODIES	Plot Use: Residential
District: SIMDEGA	Plot SubUse: Bungalow/ Dwelling / Non Apartment
Authority: SIMDEGA NAGAR PANCHAYAT	PlotNearbyReligiousStructure: NA
Inward No: SINPC/BP/0159/W02/2020	PlotSubPlot No: 2530
Application Type: General Proposal	North: -
Project Type: Building Permission	South: -
Nature of Development: New	East: -
Location of Development Area: Old Area	West: -
AREA DETAILS:	SQ.MT.
AREA OF PLOT (Minimum)	(A) 795.25
Deduction for NetPlot Area	
Surrender Free of Cost	37.16
Total	37.16
NET AREA OF PLOT(Gross Plot Area - Deduction from Gross Plot area)	(A-Deductions) 758.09
Deduction for Balance Plot Area(from Gross Plot Area)	
Surrender Free of Cost	37.16
Common Plot	69.28
Total	106.44
BALANCE AREA OF PLOT(Net Plot Area - Recreational/Amenity space)	(A-Deductions) 688.81
PLOT AREA FOR COVERAGE(Net Plot Area)	(A-Deductions) 758.09
Plot Area for FAR (Net Plot Area + RoadWidening Area)	(A-Deductions) 795.25
COVERAGE CHECK	
Permissible Coverage area ( 60.00 % )	454.85
Proposed Coverage Area ( 14.21 % )	107.69
Total Prop. Coverage Area ( 14.21 % )	107.69
Balance coverage area ( 45.79 % )	347.16
FAR CHECK	
Perm. FAR Area ( 1.50 )	1192.88
Total Perm. FAR area	1192.88
Residential FAR	215.38
Proposed FAR Area	215.38
Total Proposed FAR Area	215.38
Consumed FAR (Factor)	0.27
Balance FAR Area	977.50
BUILT UP AREA CHECK	
Total Proposed BuiltUp Area	215.38
ARCHITECT (Regd)	RAJESH KUMAR
ENGINEER (Regd)	
SUPERVISOR (Regd)	
OWNER (Regd)	LACHHENDRA SAHU
DEVELOPMENT AUTHORITY	LOCAL BODY

COLOR INDEX	
PLOT BOUNDARY	Black
ABUTTING ROAD	Green
PROPOSED CONSTRUCTION	Red
COMMON PLOT	Yellow
ROAD WIDENING AREA	Orange
EXISTING (To be retained)	Blue
EXISTING (To be demolished)	Light Blue

Buildingwise Floor FAR Details

Floor Name	Building Name A1 (RESIDENCE)		Total	
	Proposed Built Up Area (Sq.mt.)	Proposed FAR Area (Sq.mt.)	Total Proposed Built Up Area (Sq.mt.)	Total FAR Area (Sq.mt.)
Ground Floor	107.69	107.69	107.69	107.69
First Floor	107.69	107.69	107.69	107.69
Terrace Floor	0.00	0.00	0.00	0.00
Total	215.38	215.38	215.38	215.38

Building USE/SUBUSE Details

Building Name	Building Use	Building SubUse	Building Structure
A1 (RESIDENCE)	Residential	Bungalow/ Dwelling / Non Apartment	Non-Highrise

LTP NAME AND SIGNATURE	STRUCTURAL ENG'S NAME AND SIGNATURE	BUILDER NAME AND SIGNATURE	DIGITAL SIGNATURE
RAJESH KUMAR SINPC/DFTMN/0006/2017			

Proposal Basic Information	
Proposal File No.	SINPC/BP/0159/W02/2020
Owner Name	LACHHENDRA SAHU
Khata No	103
Plot No	2530
Village Name	Gotra
Use	Residential
SubUse	Bungalow/ Dwelling / Non Apartment

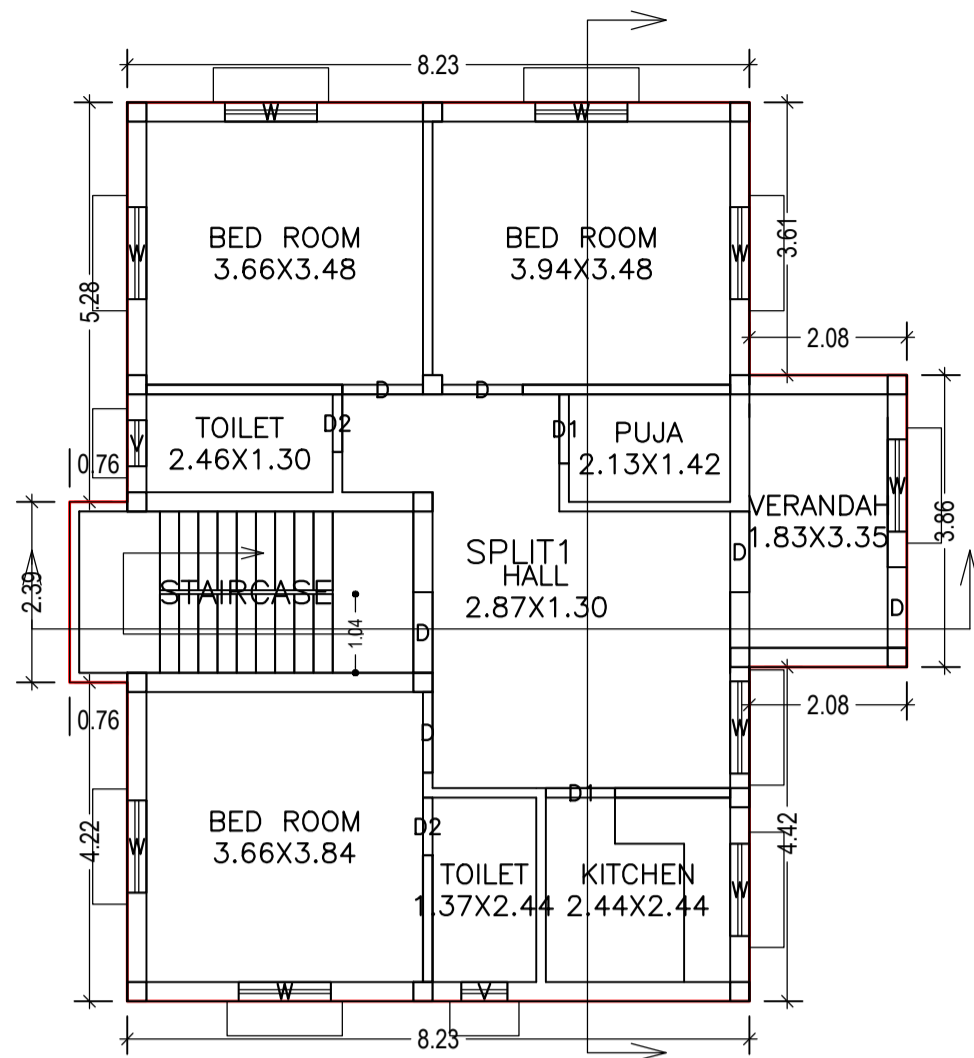

GROUND FLOOR PLAN (Proposed) (SCALE 1:100)

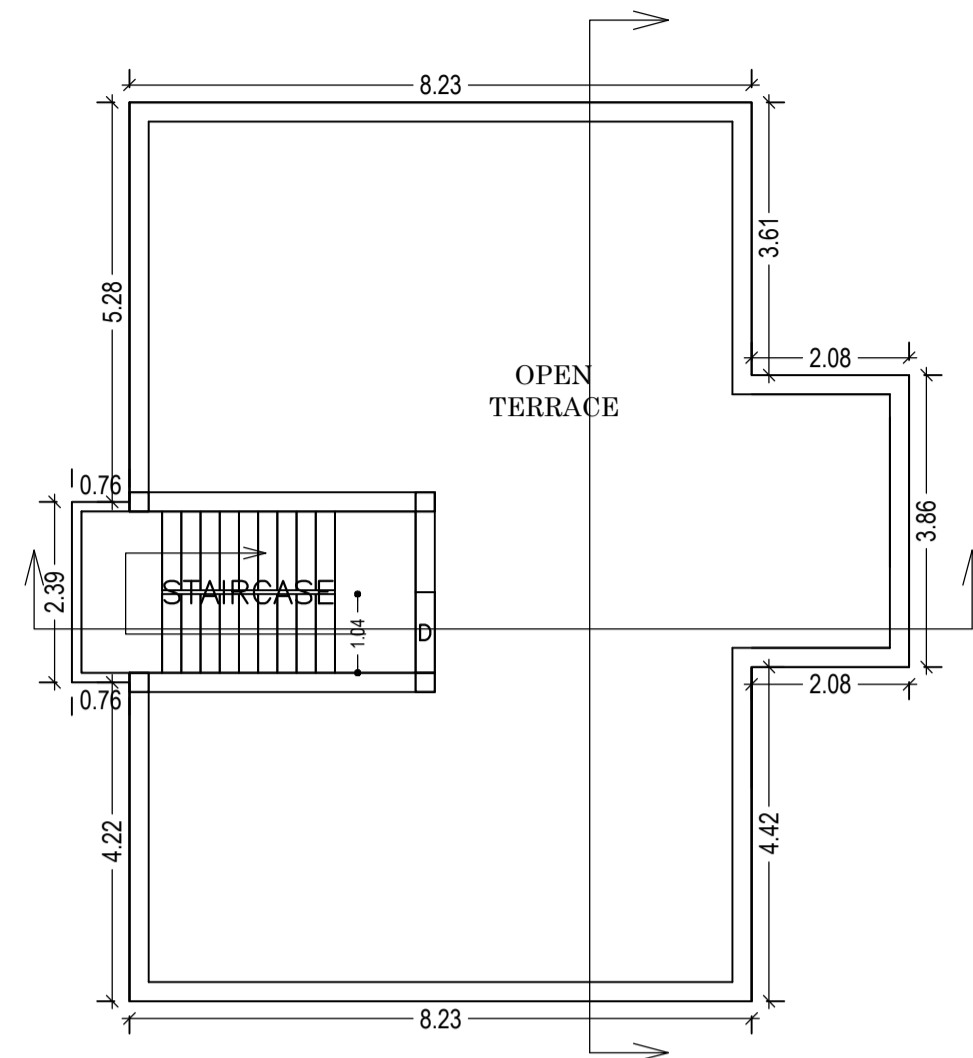

TERRACE FLOOR PLAN (SCALE 1:100)

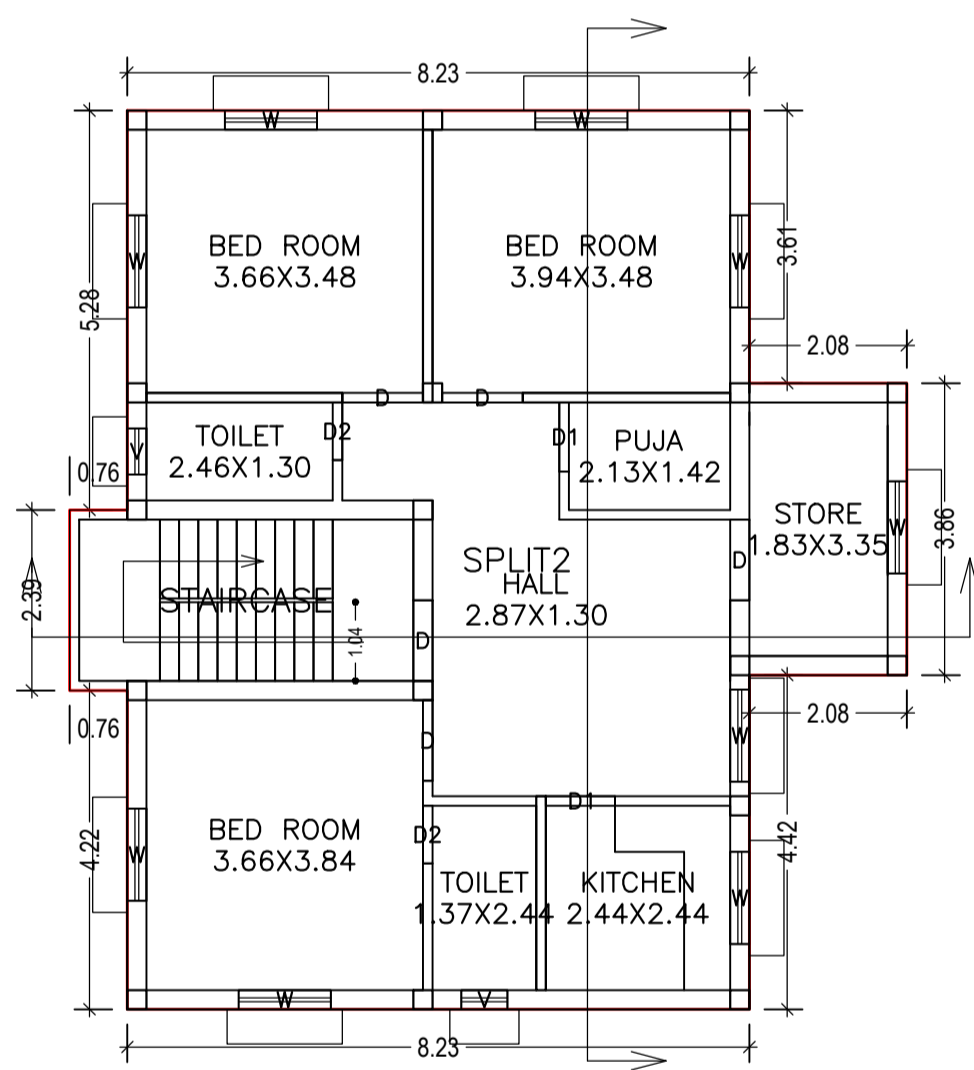

FIRST FLOOR PLAN (Proposed) (SCALE 1:100)

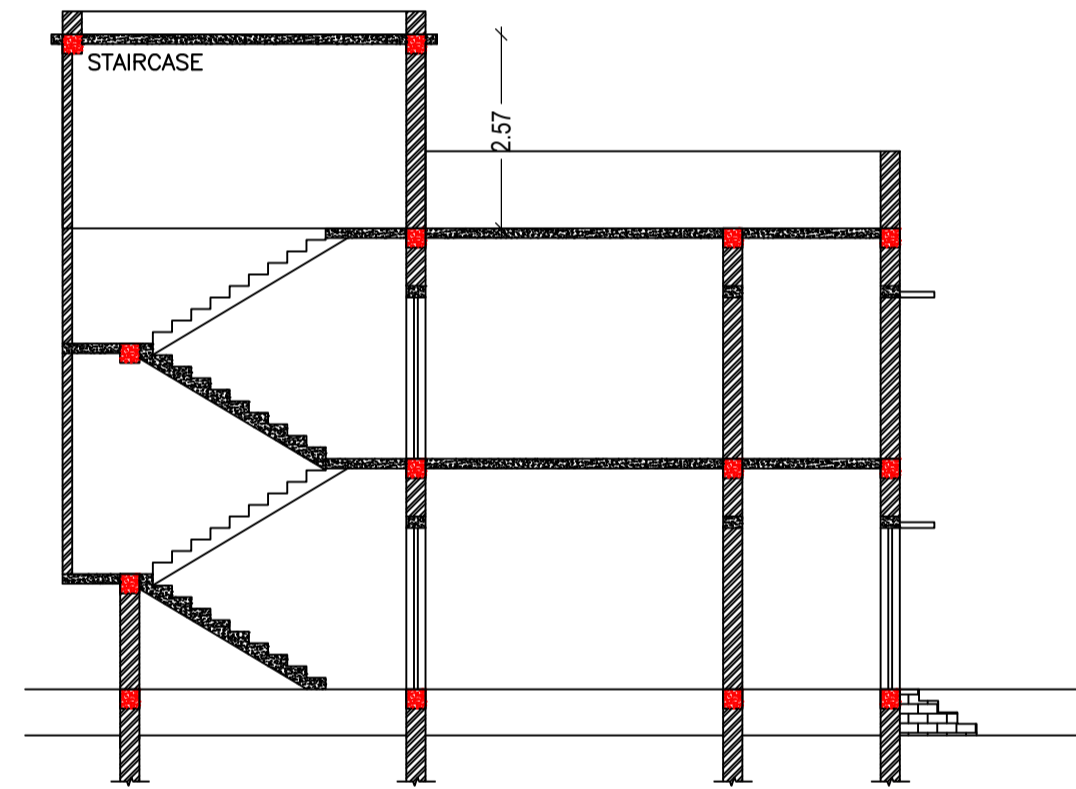
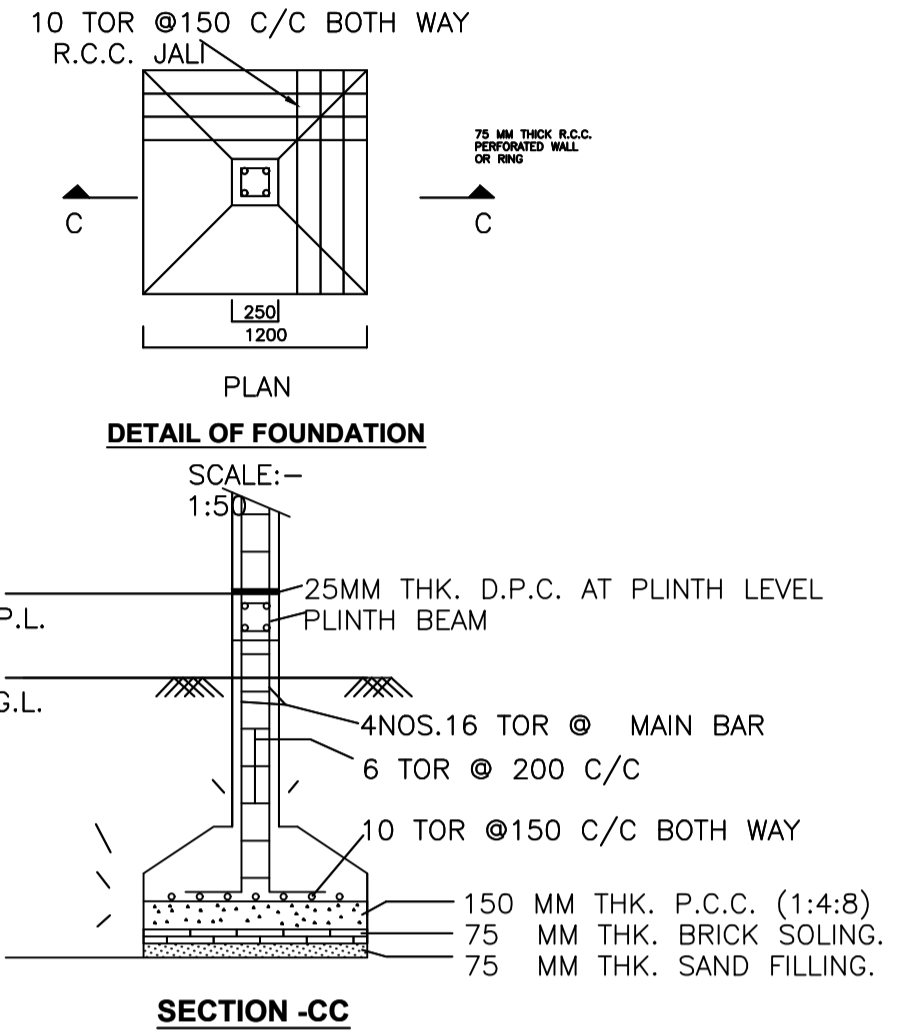
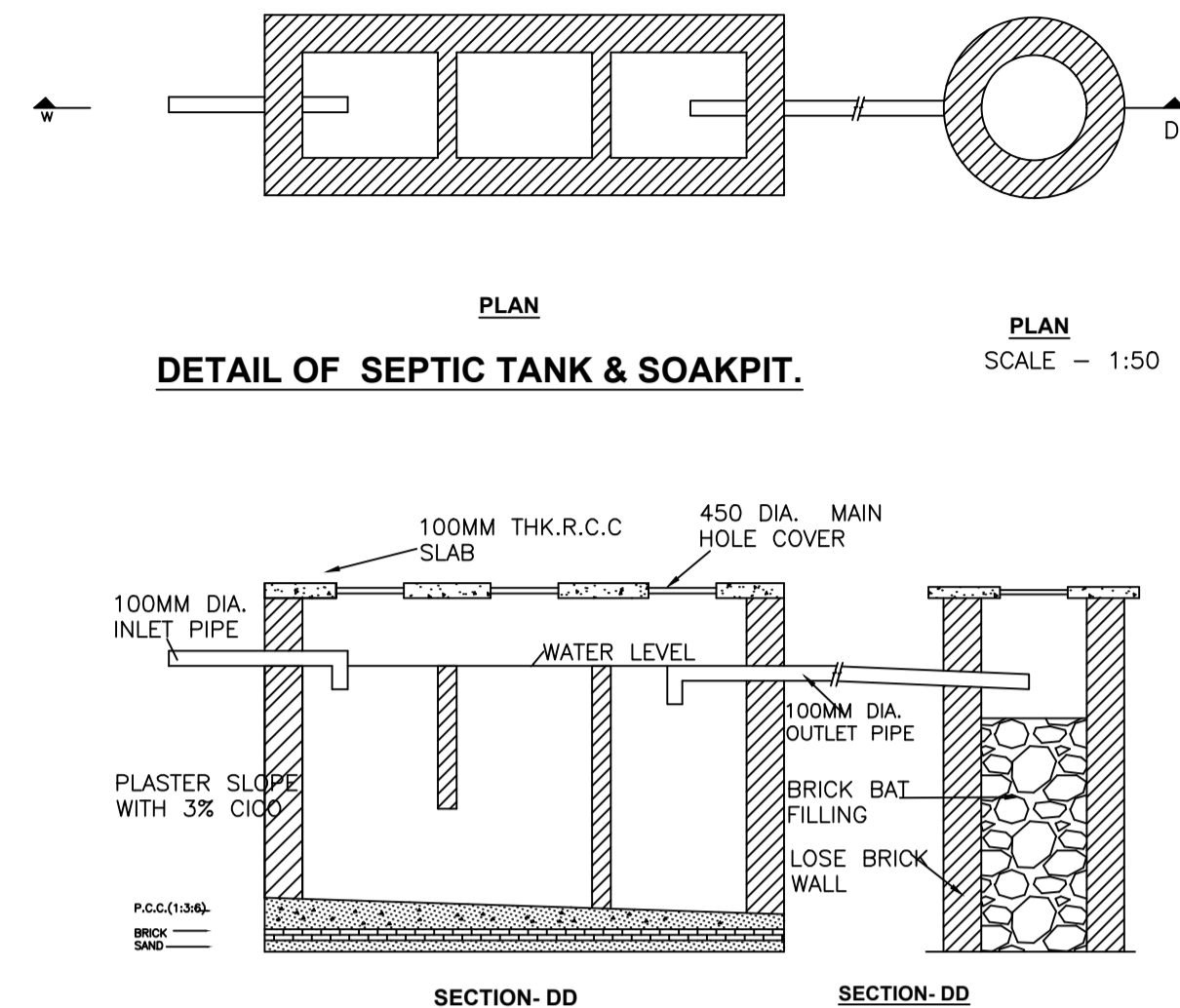
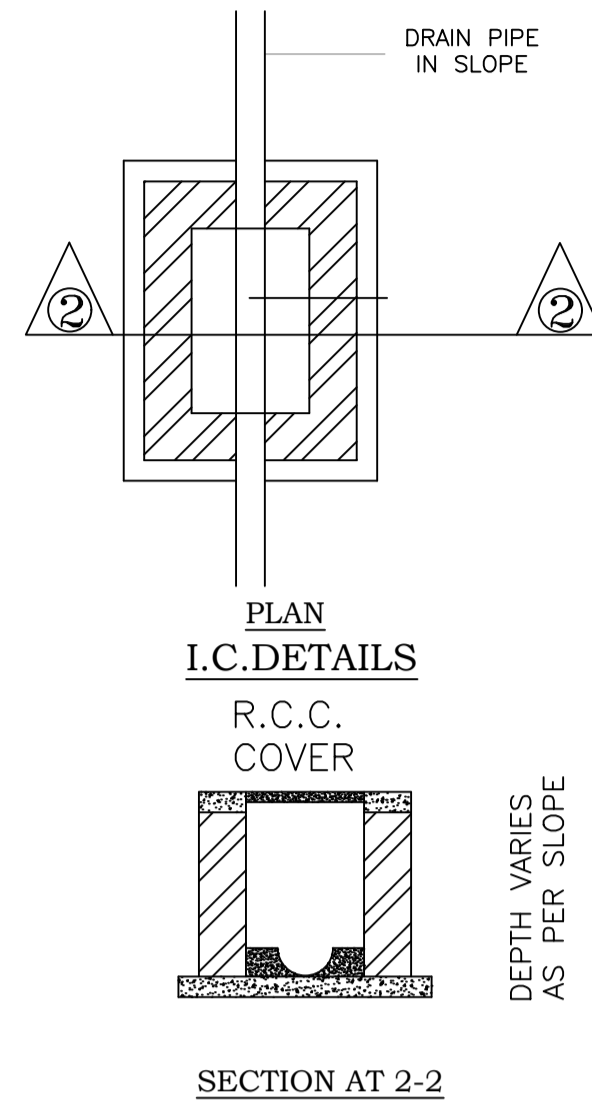

SECTION AT: X-X SCALE 1:100

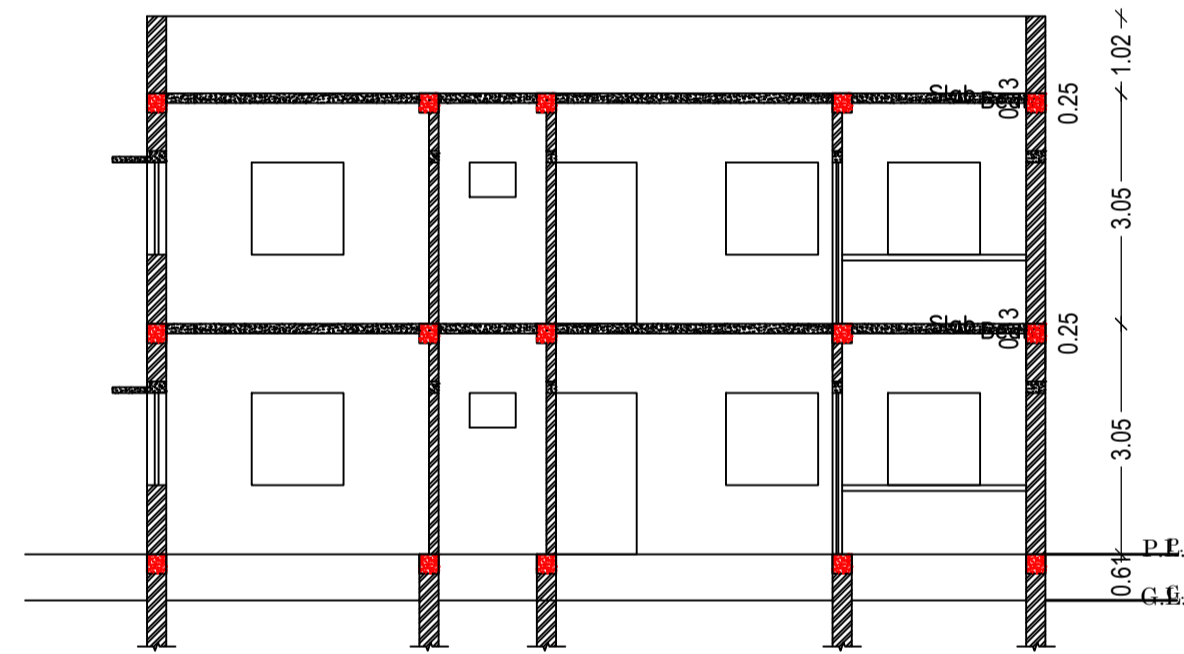

SECTION AT: Y-Y SCALE 1:100

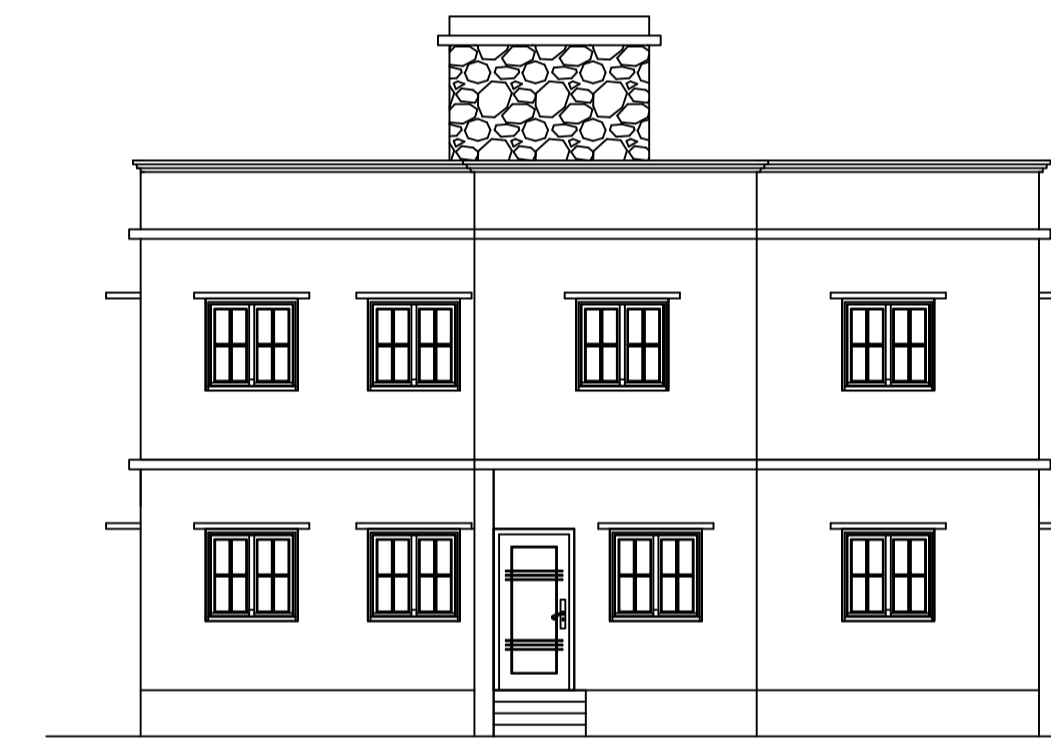

FRONT ELEVATION SCALE 1:100

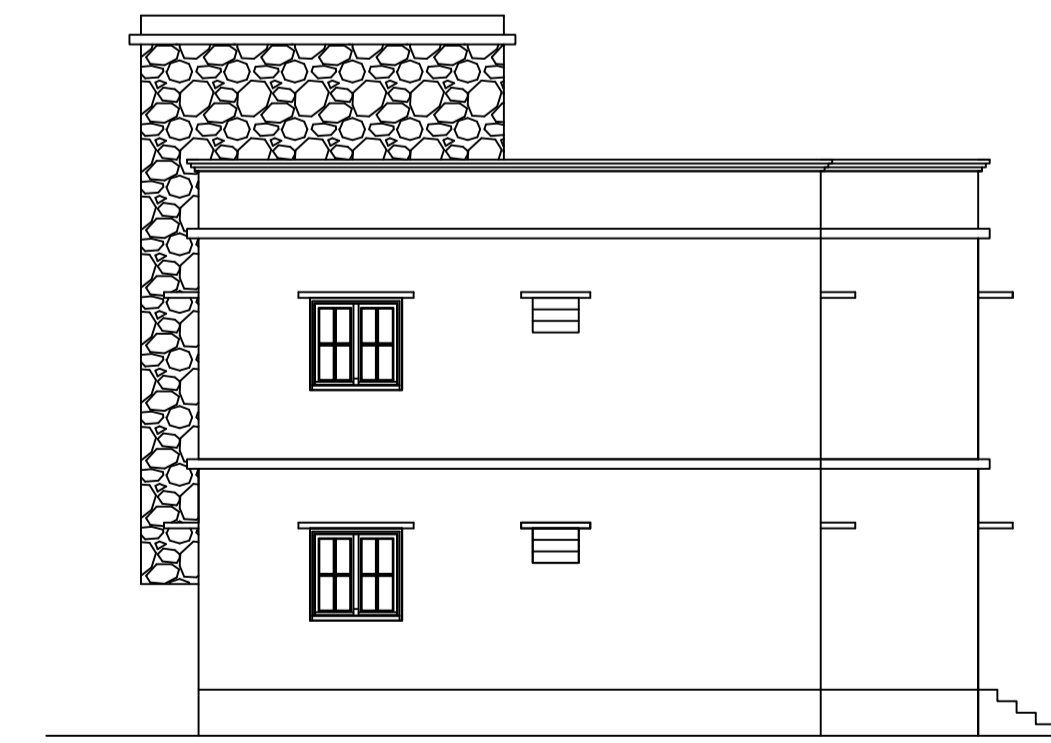

LEFT SIDE ELEVATION SCALE 1:100

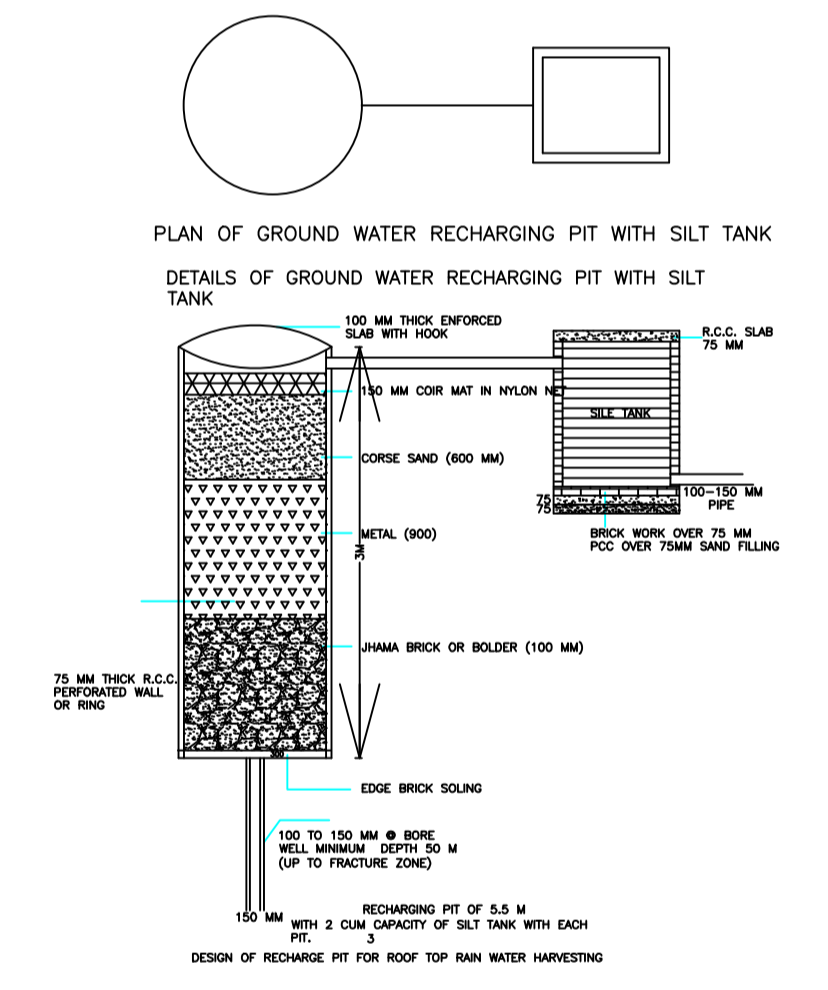

Building :A1 (RESIDENCE)					
Floor Name	Total Built Up Area (Sq.mt.)	Proposed FAR Area (Sq.mt.) Resi.	Total FAR Area (Sq.mt.)	Total Consumed Additional FAR Area (Sq.mt.)	Tnmt (No.)
Ground Floor	107.69	107.69	107.69	107.69	01
First Floor	107.69	107.69	107.69	107.69	01
Terrace Floor	0.00	0.00	0.00	0.00	00
Total :	215.38	215.38	215.38	215.38	02
Total Number of Same Buildings	1				
Total :	215.38	215.38	215.38	215.38	02

SCHEDULE OF DOOR:

BUILDING NAME	NAME	LENGTH	HEIGHT	NOS
A1 (RESIDENCE)	D2	0.76	2.10	04
A1 (RESIDENCE)	D1	0.91	2.10	04
A1 (RESIDENCE)	D	1.07	2.10	11

SCHEDULE OF WINDOW/VENTILATION:

BUILDING NAME	NAME	LENGTH	HEIGHT	NOS
A1 (RESIDENCE)	V	0.61	1.20	04
A1 (RESIDENCE)	W	1.22	1.20	18

UnitBUA Table for Building :A1 (RESIDENCE)

FLOOR	Name	UnitBUA Type	UnitBUA Area	Carpet Area	No. of Rooms	No. of Tenement
GROUND FLOOR PLAN	SPLIT1	FLAT	84.85	83.77	9	1
FIRST FLOOR PLAN	SPLIT2	FLAT	84.85	83.39	9	1
Total:	-	-	169.70	167.16	18	2

LTP NAME AND SIGNATURE	STRUCTURAL ENG'S NAME AND SIGNATURE	BUILDER NAME AND SIGNATURE	DIGITAL SIGNATURE
RAJESH KUMAR SINPC/DFTMN/0006/2017			

Proposal Basic Information	
Proposal File No.	SINPC/BP/0159/W02/2020
Owner Name	LACHHENDRA SAHU
Khata No	103
Plot No	2530
Village Name	Gotra
Use	Residential
SubUse	Bungalow/ Dwelling / Non Apartment

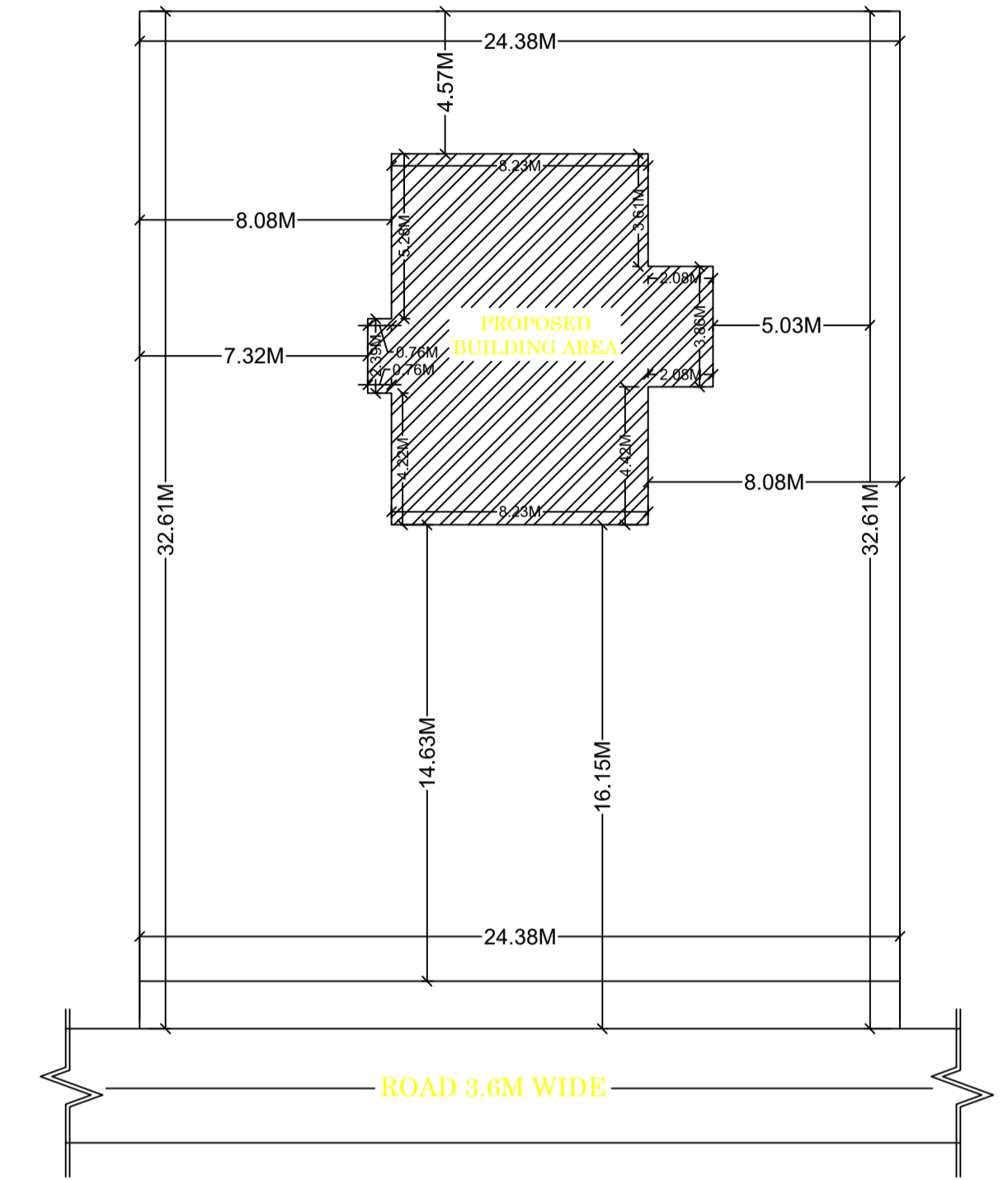

**KEY PLAN**  
SCALE 1:200

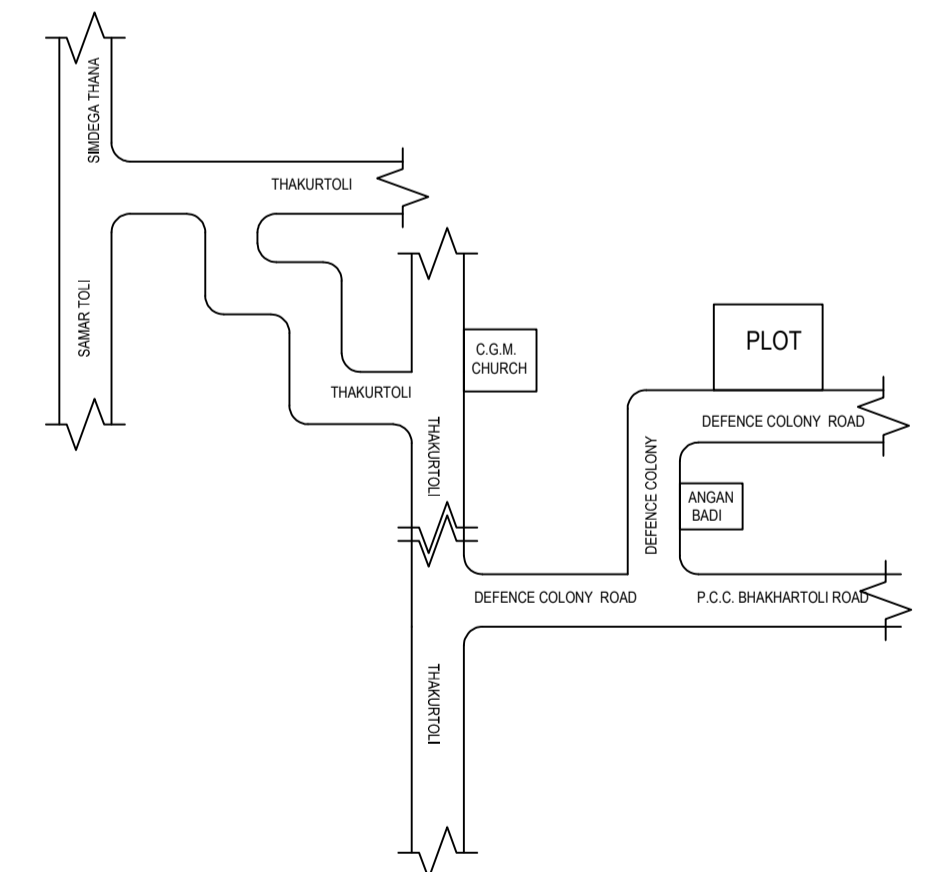

**LOCATION PLAN**  
SCALE 1:200

LTP NAME AND SIGNATURE	STRUCTURAL ENG'S NAME AND SIGNATURE	BUILDER NAME AND SIGNATURE	DIGITAL SIGNATURE
RAJESH KUMAR SINPC/DFTMN/0006/2017			