

FAR & Tenement Details (Table 4c-1)

Building	No. of Same Bldg	Total Built Up Area (Sq.mt.)	Proposed FAR Area (Sq.mt.) Resi.	Total FAR Area (Sq.mt.)	Total Consumed Additional FAR Area (Sq.mt.)	Tnmt (No.)
A1 (RESIDENCE)	1	247.36	247.36	247.36	247.36	02
Grand Total	1	247.36	247.36	247.36	247.36	02

Proposal Basic Information

Proposal File No.	SINPC/BP/0162/W05/2020
Owner Name	ANIL KUJUR
Khata No	50
Plot No	5138,5139
Village Name	Gotra
Use	Residential
SubUse	Bungalow/ Dwelling / Non Apartment

Required Parking (Table 7a)

Building Name	Type	SubUse	Area (Sq.mt.)	Units		Car		Visitors Car			
				Reqd.	Prop.	Reqd./Unit	Reqd.	Prop.	Reqd./Unit	Reqd.	Prop.
A1 (RESIDENCE)	Residential	Bungalow/ Dwelling / Non Apartment	>0	1	2.00	1	2	-	-	-	-
			>0	1	2.00	-	-	-	1	1	-
Total			-	-	-	-	2	3	-	1	1

Parking Check (Table 7b)

Vehicle Type	Reqd.		Prop.	
	No.	Area	No.	Area
Car	-	-	3	55.18
Total Car	2	25.00	3	55.18
Visitor's Car Parking	-	-	1	17.59
Total Visitor Parking	1	12.50	1	17.59
Total		37.50		90.36

AREA STATEMENT SIMDEGA NAGAR PANCHAYAT	VERSION NO. : 1.0.43
PROJECT DETAIL:	VERSION DATE: 29/04/2019
Region: JHARKHAND URBAN LOCAL BODIES	Plot Use: Residential
District: SIMDEGA	Plot SubUse: Bungalow/ Dwelling / Non Apartment
Authority: SIMDEGA NAGAR PANCHAYAT	PlotNearbyReligiousStructure: NA
Inward No: SINPC/BP/0162/W05/2020	PlotSubPlot No: 5138,5139
Application Type: General Proposal	North: -
Project Type: Building Permission	South: -
Nature of Development: New	East: -
Location of Development Area: Old Area	West: -
AREA DETAILS:	SQ.MT.
AREA OF PLOT (Minimum)	(A) 592.16
Deduction for NetPlot Area	
Surrender Free of Cost	34.03
Total	34.03
NET AREA OF PLOT(Gross Plot Area - Deduction from Gross Plot area)	(A-Deductions) 558.12
Deduction for Balance Plot Area(from Gross Plot Area)	
Surrender Free of Cost	34.03
Common Plot	105.79
Total	139.83
BALANCE AREA OF PLOT(Net Plot Area - Recreational/Amenity space)	(A-Deductions) 452.33
PLOT AREA FOR COVERAGE(Net Plot Area)	(A-Deductions) 558.12
Plot Area for FAR (Net Plot Area + RoadWidening Area)	(A-Deductions) 592.16
COVERAGE CHECK	
Permissible Coverage area (60.00 %)	334.87
Proposed Coverage Area (22.16 %)	123.68
Total Prop. Coverage Area (22.16 %)	123.68
Balance coverage area (37.84 %)	211.19
FAR CHECK	
Perm. FAR Area (1.50)	888.24
Total Perm. FAR area	888.24
Residential FAR	247.35
Proposed FAR Area	247.35
Total Proposed FAR Area	247.35
Consumed FAR (Factor)	0.42
Balance FAR Area	640.89
BUILT UP AREA CHECK	
Total Proposed BuiltUp Area	247.36
ARCHITECT (Regd)	RAJESH KUMAR
ENGINEER (Regd)	
SUPERVISOR (Regd)	
OWNER (Regd)	ANIL KUJUR
DEVELOPMENT AUTHORITY	LOCAL BODY

COLOR INDEX	
PLOT BOUNDARY	Black
ABUTTING ROAD	Green
PROPOSED CONSTRUCTION	Red
COMMON PLOT	Yellow
ROAD WIDENING AREA	Light Blue
EXISTING (To be retained)	Blue
EXISTING (To be demolished)	Light Yellow

Buildingwise Floor FAR Details

Floor Name	Building Name		Total	
	Proposed Built Up Area (Sq.mt.)	Proposed FAR Area (Sq.mt.)	Total Proposed Built Up Area (Sq.mt.)	Total FAR Area (Sq.mt.)
Ground Floor	123.68	123.68	123.68	123.68
First Floor	123.68	123.68	123.68	123.68
Terrace Floor	0.00	0.00	0.00	0.00
Total	247.36	247.36	247.36	247.36

Building USE/SUBUSE Details

Building Name	Building Use	Building SubUse	Building Structure
A1 (RESIDENCE)	Residential	Bungalow/ Dwelling / Non Apartment	Non-Highrise

LTP NAME AND SIGNATURE	STRUCTURAL ENG'S NAME AND SIGNATURE	BUILDER NAME AND SIGNATURE	DIGITAL SIGNATURE
RAJESH KUMAR SINPC/DFTMN/0006/2017			

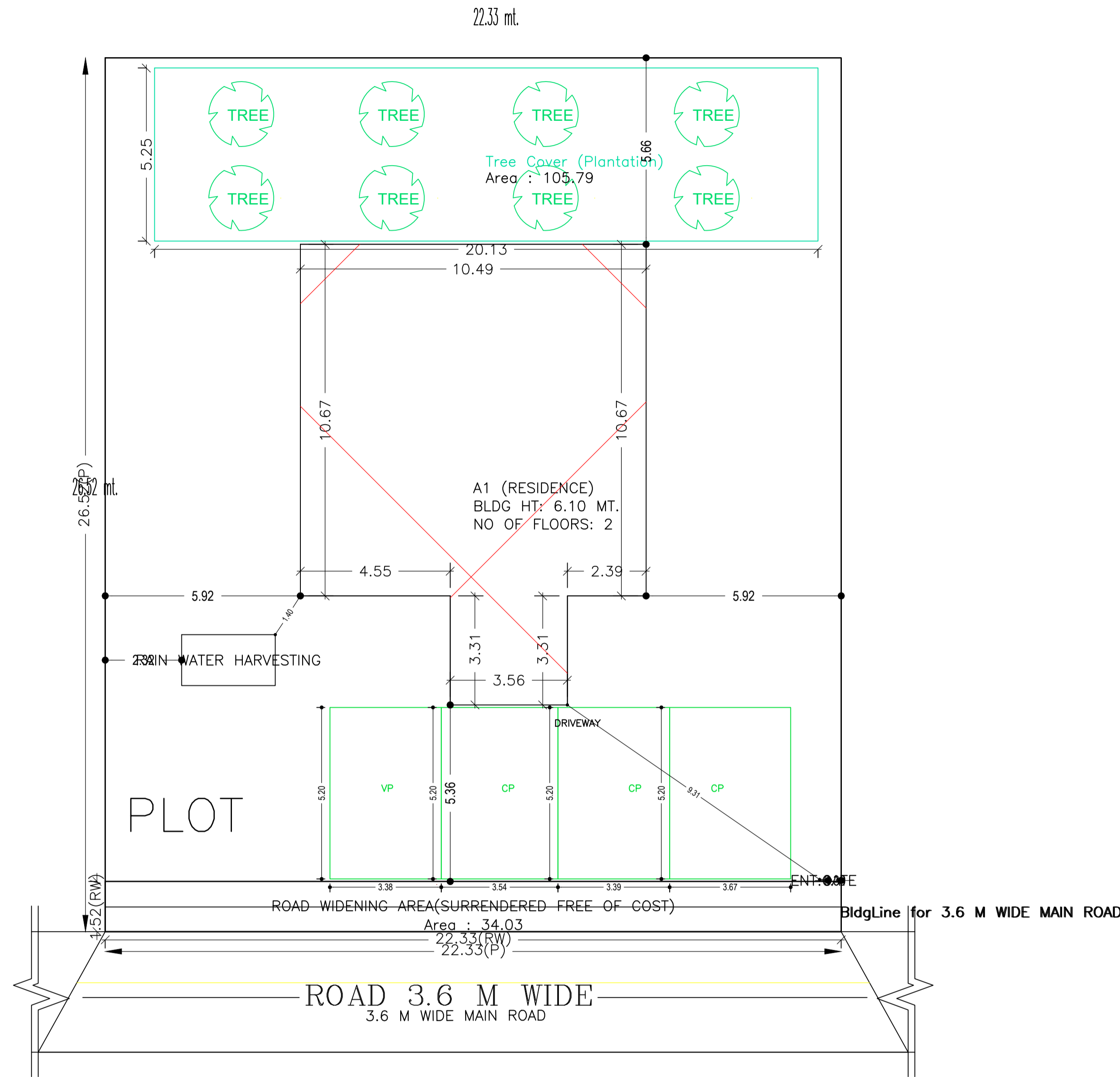

SITE PLAN

Proposal Basic Information

Proposal File No.	SINPC/BI/0162/W05/2020
Owner Name	ANIL KUJUR
Khata No	50
Plot No	5138,5139
Village Name	Gotra
Use	Residential
SubUse	Bungalow/ Dwelling / Non Apartment

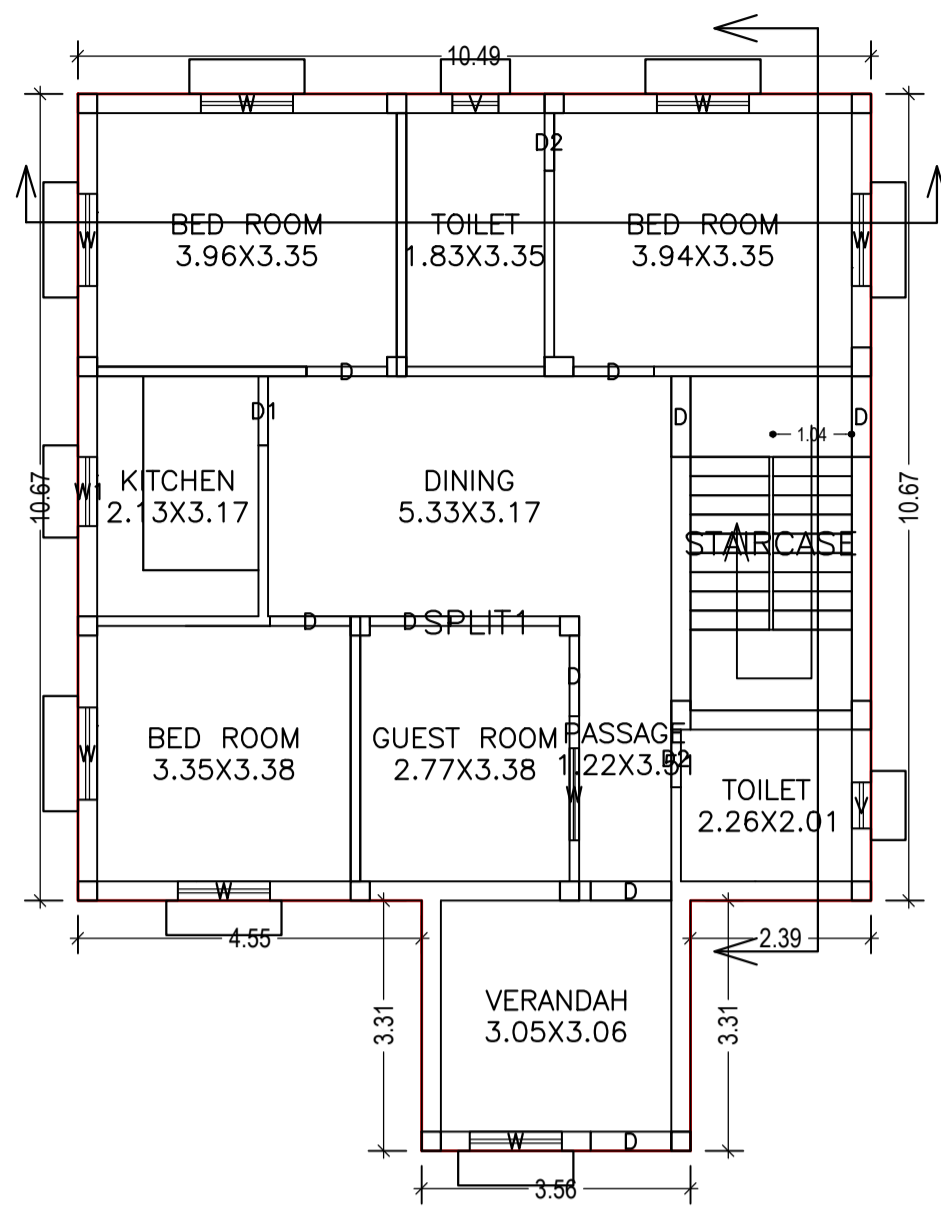

GROUND FLOOR PLAN (Proposed) (SCALE 1:100)

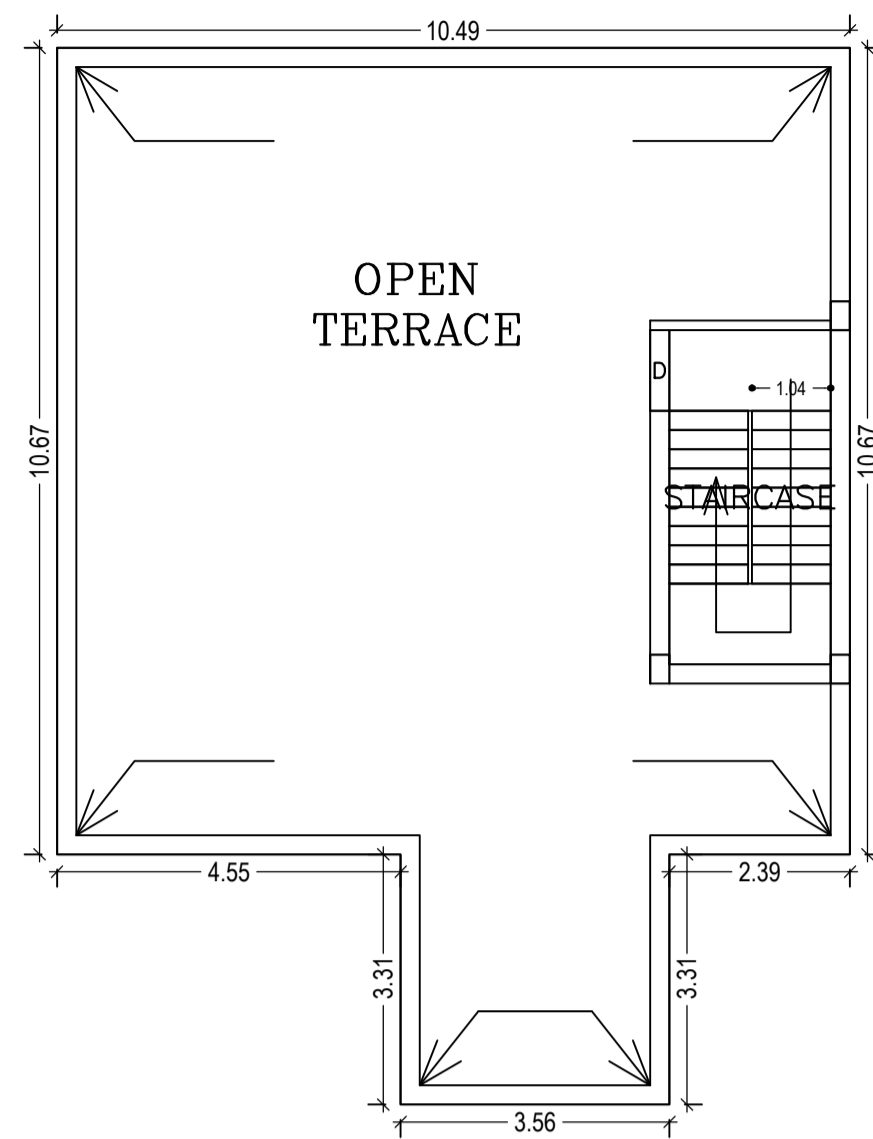

TERRACE FLOOR PLAN (SCALE 1:100)

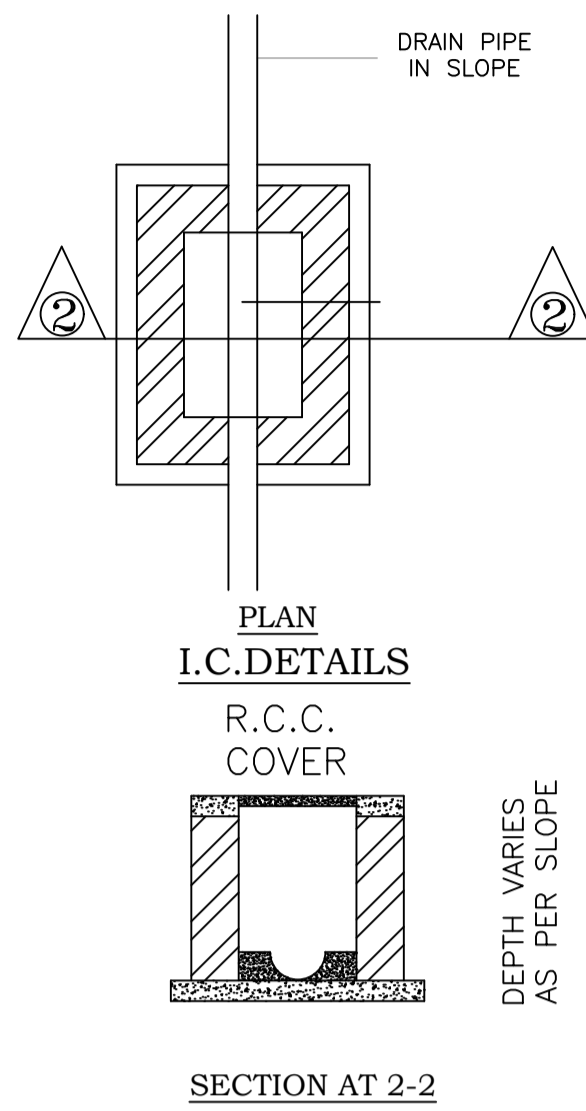

SECTION AT 2-2

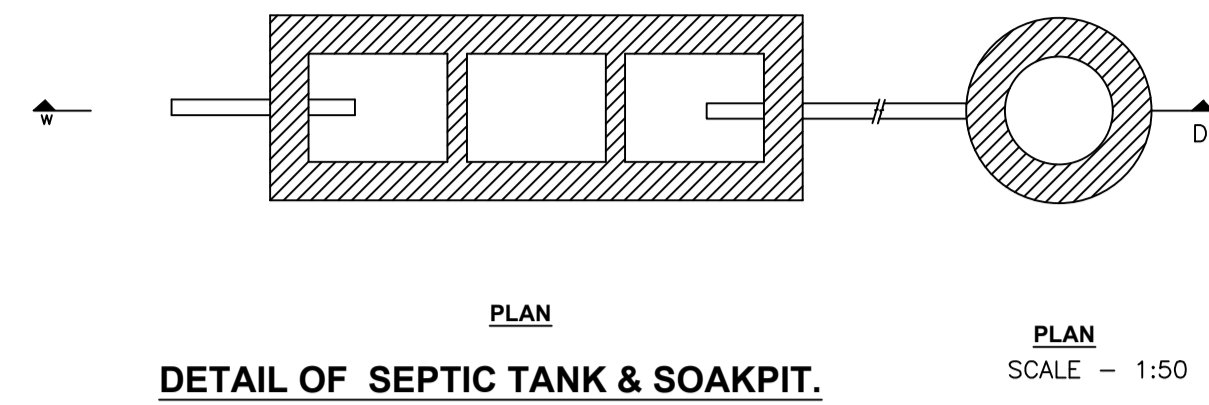

DETAIL OF SEPTIC TANK & SOAKPIT.

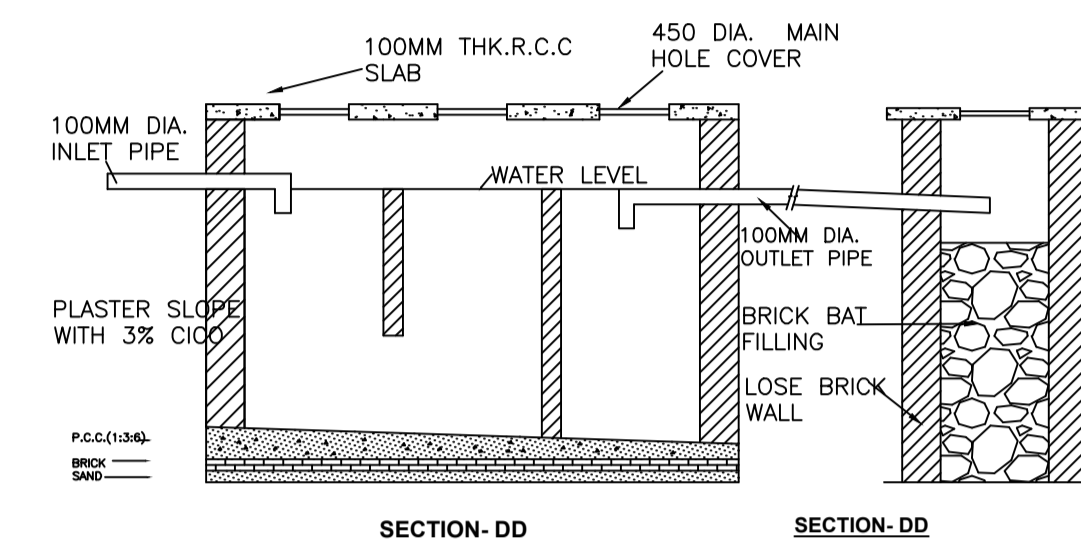

SECTION-DD

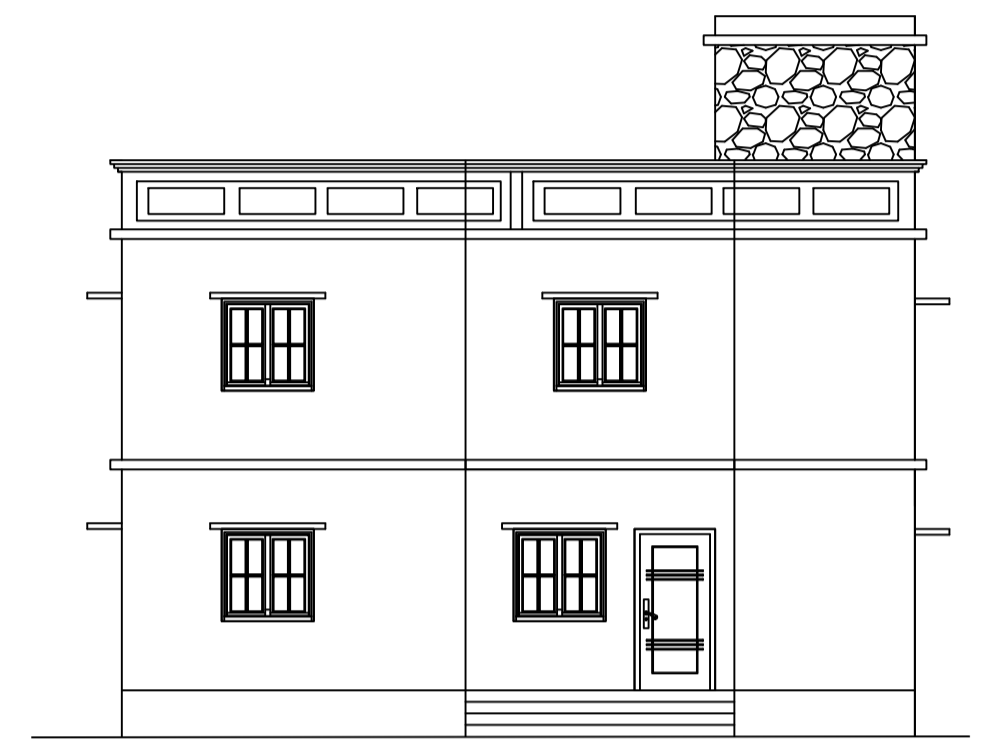

FRONT ELEVATION (SCALE 1:100)

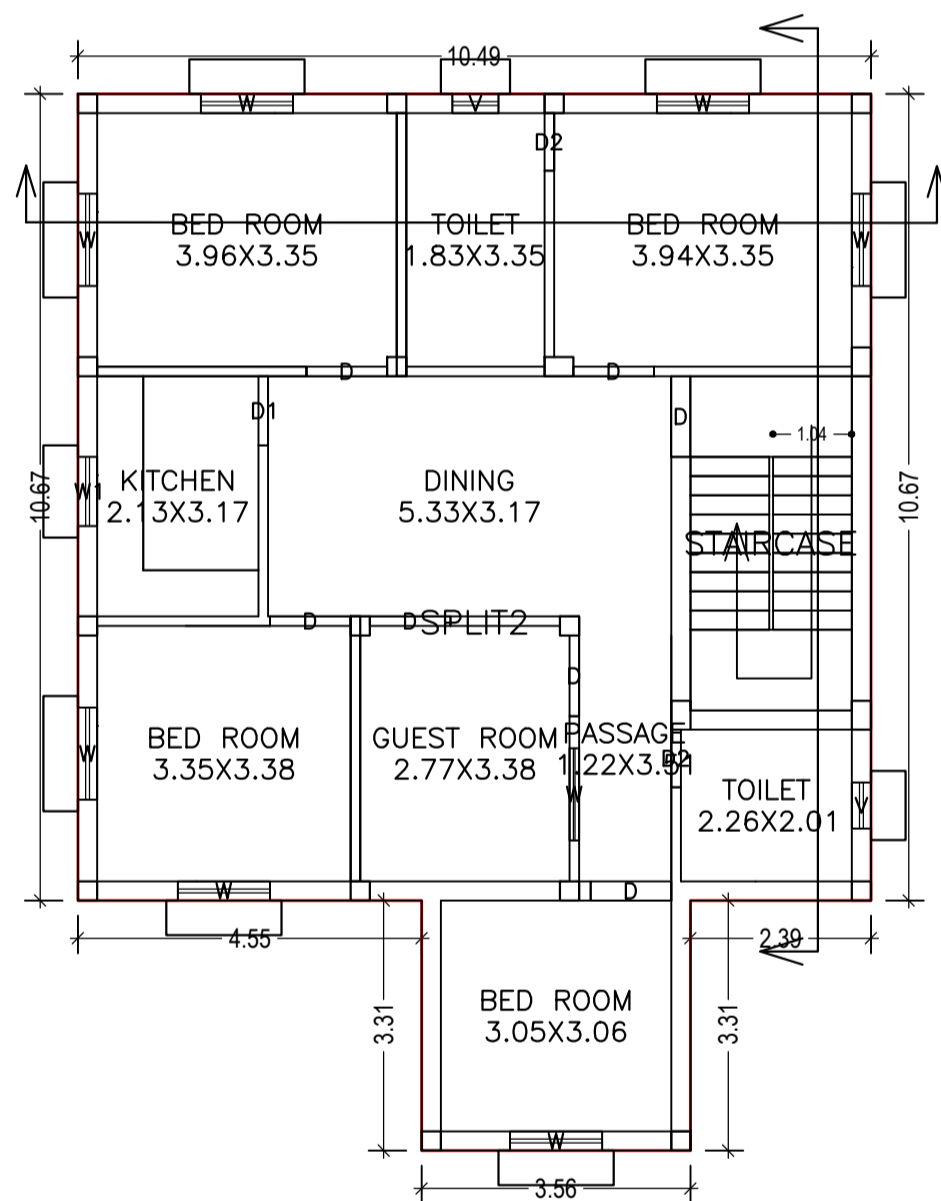

FIRST FLOOR PLAN (Proposed) (SCALE 1:100)

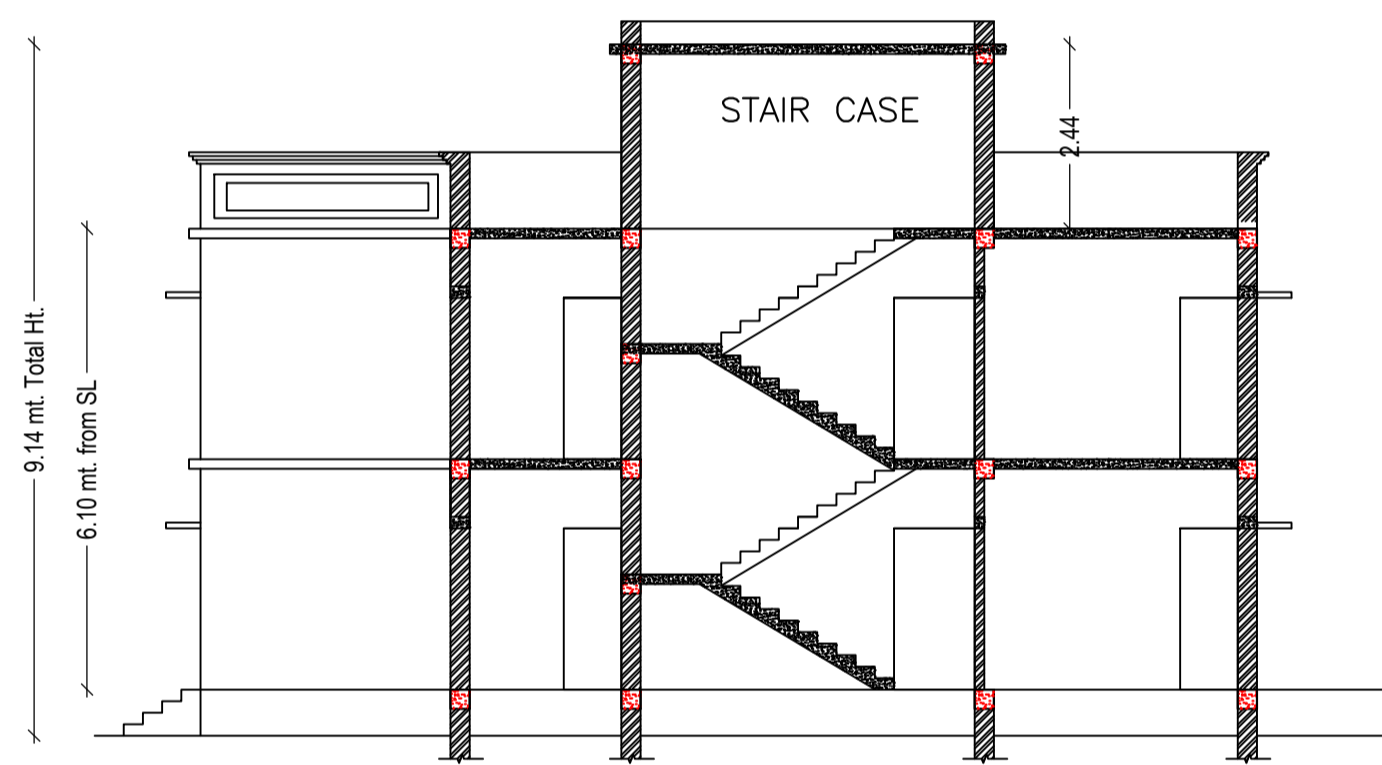

SECTION AT: X-X (SCALE 1:100)

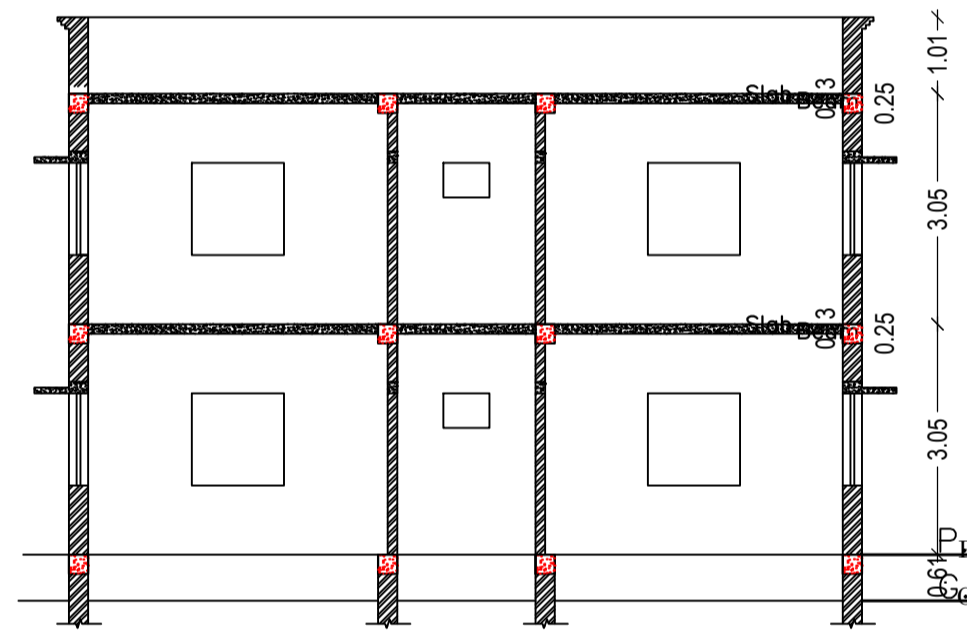

SECTION AT: Y-Y (SCALE 1:100)

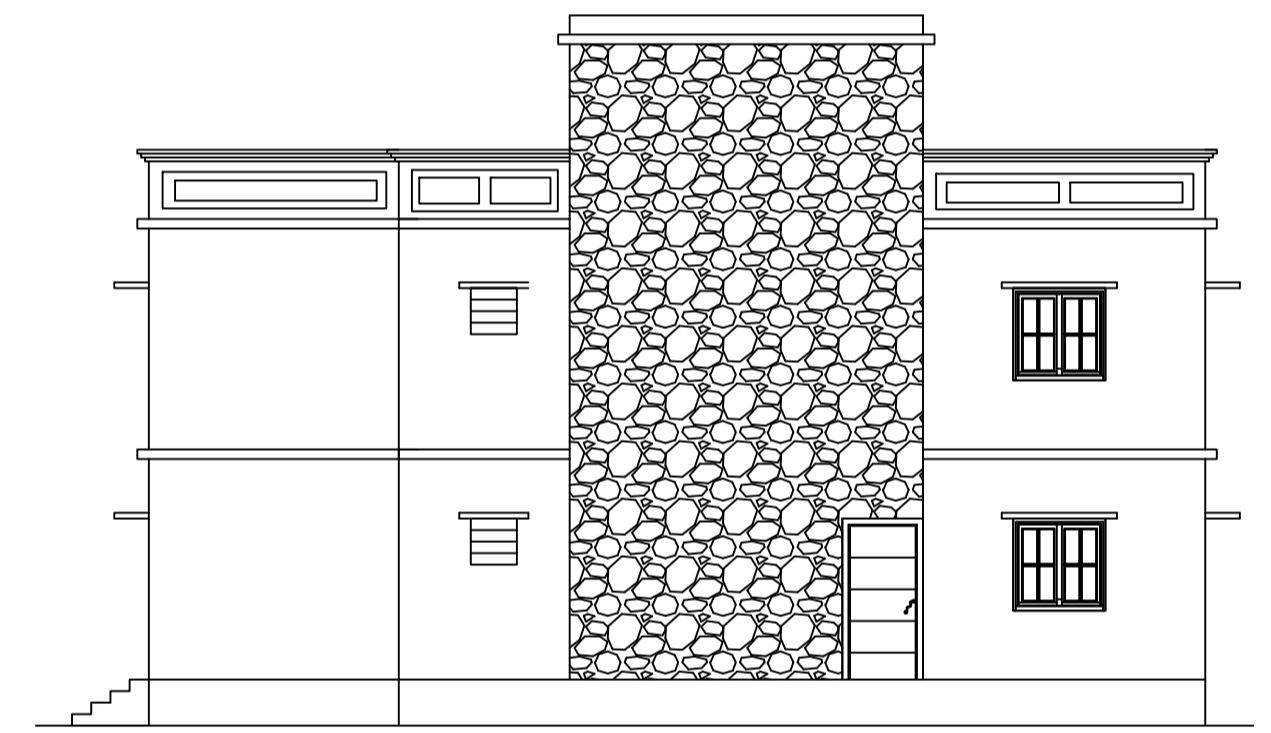

LEFT SIDE ELEVATION (SCALE 1:100)

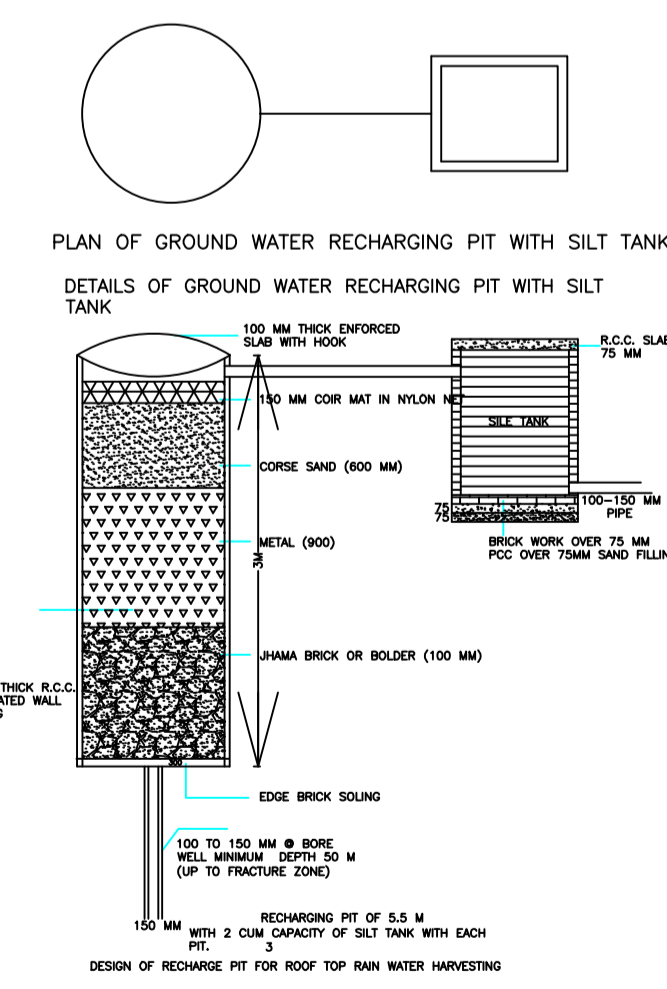

PLAN OF GROUND WATER RECHARGING PIT WITH SILT TANK

DETAILS OF GROUND WATER RECHARGING PIT WITH SILT TANK

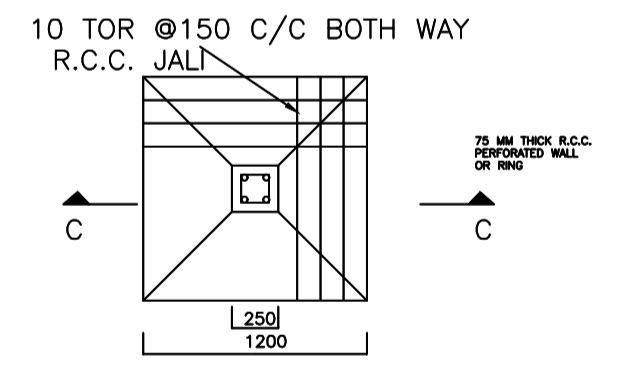

DETAIL OF FOUNDATION

SCALE: 1:50

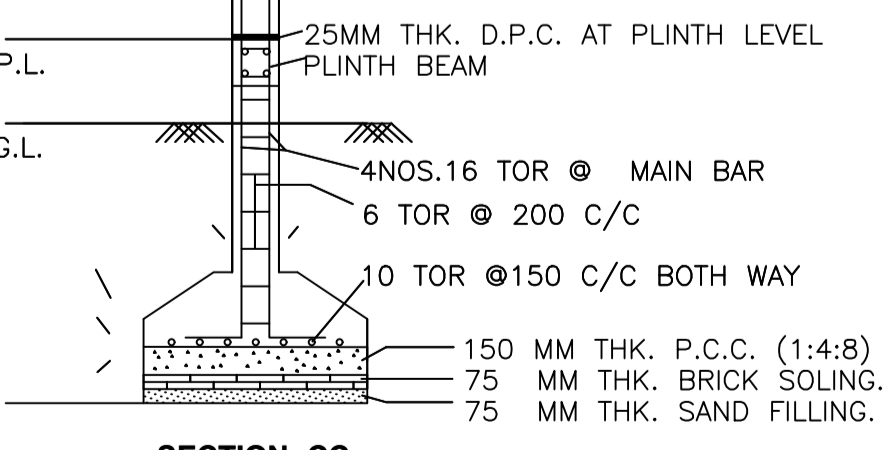

SECTION-CC

Building :A1 (RESIDENCE)

Floor Name	Total Built Up Area (Sq.mt.)	Proposed FAR Area (Sq.mt.)	Total FAR Area (Sq.mt.)	Total Consumed Additional FAR Area (Sq.mt.)	Tnmt (No.)
Ground Floor	123.68	123.68	123.68	123.68	01
First Floor	123.68	123.68	123.68	123.68	01
Terrace Floor	0.00	0.00	0.00	0.00	00
Total:	247.36	247.36	247.36	247.36	02
Total Number of Same Buildings	1				
Total:	247.36	247.36	247.36	247.36	02

SCHEDULE OF DOOR:

BUILDING NAME	NAME	LENGTH	HEIGHT	NOS
A1 (RESIDENCE)	D2	0.76	2.10	04
A1 (RESIDENCE)	D1	0.91	2.10	02
A1 (RESIDENCE)	D	1.07	2.10	15

SCHEDULE OF WINDOW/VENTILATION:

BUILDING NAME	NAME	LENGTH	HEIGHT	NOS
A1 (RESIDENCE)	V	0.61	1.20	04
A1 (RESIDENCE)	W1	0.91	1.20	02
A1 (RESIDENCE)	W	1.22	1.20	16

UnitBUA Table for Building :A1 (RESIDENCE)

FLOOR	Name	UnitBUA Type	UnitBUA Area	Carpet Area	No. of Rooms	No. of Tenement
GROUND FLOOR PLAN	SPLIT1	FLAT	100.04	98.81	10	1
FIRST FLOOR PLAN	SPLIT2	FLAT	100.04	98.81	10	1
Total:	-	-	200.08	197.62	20	2

LTP NAME AND SIGNATURE	STRUCTURAL ENG'S NAME AND SIGNATURE	BUILDER NAME AND SIGNATURE	DIGITAL SIGNATURE
RAJESH KUMAR SINPC/DFTMN/0006/2017			

Proposal Basic Information	
Proposal File No.	SINPC/BP/0162/W05/2020
Owner Name	ANIL KUJUR
Khata No	50
Plot No	5138,5139
Village Name	Gotra
Use	Residential
SubUse	Bungalow/ Dwelling / Non Apartment

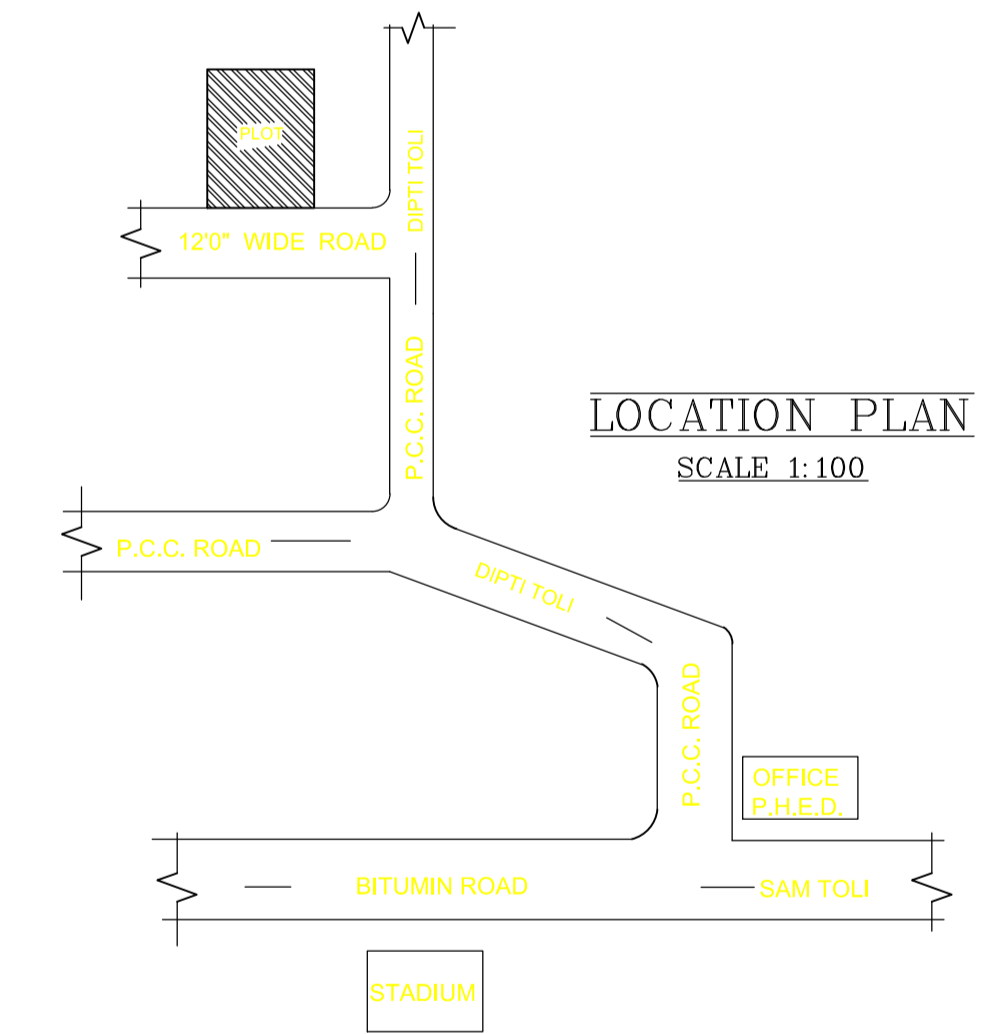
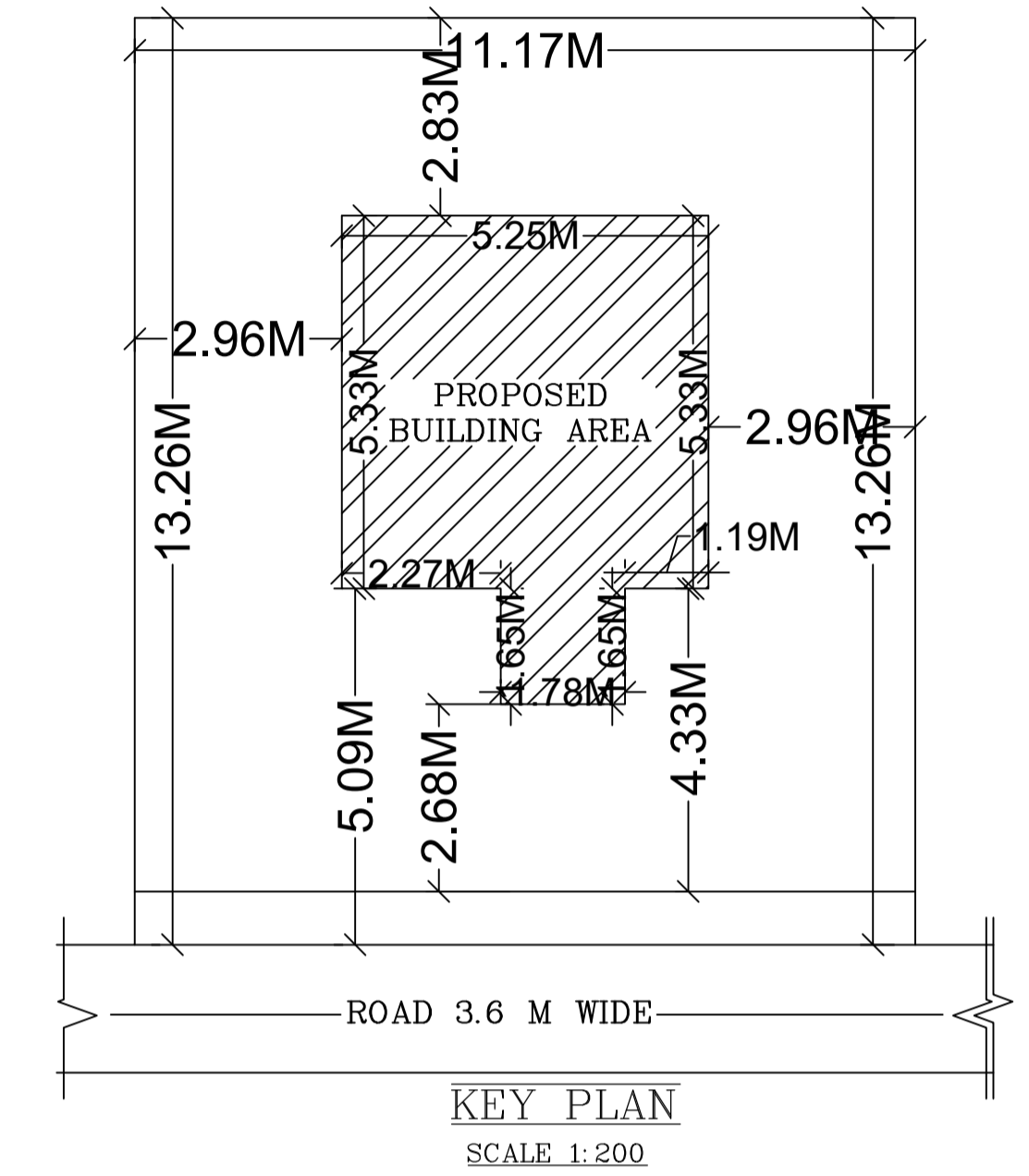

LTP NAME AND SIGNATURE	STRUCTURAL ENG'S NAME AND SIGNATURE	BUILDER NAME AND SIGNATURE	DIGITAL SIGNATURE
RAJESH KUMAR SINPC/DFTMN/0006/2017			