

SITE PLAN

(Scale - 1:200)

FAR & Tenement Details (Table 4c-1)

Building	No. of Same Bldg	Total Built Up Area (Sq.mt.)	Proposed FAR Area (Sq.mt.) Resi.	Total FAR Area (Sq.mt.)	Total Consumed Additional FAR Area (Sq.mt.)	Tnmt (No.)
A1 (RESIDENCE)	1	147.09	147.09	147.09	147.09	01
Grand Total	1	147.09	147.09	147.09	147.09	01

Proposal Basic Information

Proposal File No.	SINPC/BP/0179/W05/2020
Owner Name	RAJENDRA EKKA
Khata No	97
Plot No	3508
Village Name	Gotra
Use	Residential
SubUse	Bungalow/ Dwelling / Non Apartment

AREA STATEMENT SIMDEGA NAGAR PANCHAYAT		VERSION NO: 1.0.46
PROJECT DETAIL:		VERSION DATE: 22/06/2020
Region: JHARKHAND URBAN LOCAL BODIES	Plot Use: Residential	
District: SIMDEGA	Plot SubUse: Bungalow/ Dwelling / Non Apartment	
Authority: SIMDEGA NAGAR PANCHAYAT	PlotNearbyReligiousStructure: NA	
Inward No: SINPC/BP/0179/W05/2020	PlotSubPlot No: 3508	
Application Type: General Proposal	North: -	
Project Type: Building Permission	South: -	
Nature of Development: New	East: -	
Location of Development Area: Old Area	West: -	
AREA DETAILS:		
AREA OF PLOT (Minimum)	(A)	SQ.MT. 2138.60
Deduction for NetPlot Area		
Surrender Free of Cost		60.83
Total		60.83
NET AREA OF PLOT(Gross Plot Area - Deduction from Gross Plot area)		
(A-Deductions)		2077.77
Deduction for Balance Plot Area(from Gross Plot Area)		
Surrender Free of Cost		60.83
Common Plot		117.92
Total		178.75
BALANCE AREA OF PLOT(Net Plot Area - Recreational/Amenity space)		
(A-Deductions)		1959.85
PLOT AREA FOR COVERAGE(Net Plot Area)		
(A-Deductions)		2077.77
Plot Area for FAR (Net Plot Area + RoadWidening Area)		
(A-Deductions)		2138.60
COVERAGE CHECK		
Permissible Coverage area (50.00 %)		1038.89
Proposed Coverage Area (7.08 %)		147.09
Total Prop. Coverage Area (7.08 %)		147.09
Balance coverage area (42.92 %)		891.80
FAR CHECK		
Perm. FAR Area (1.50)		3207.90
Total Perm. FAR area		3207.90
Residential FAR		147.09
Proposed FAR Area		147.09
Total Proposed FAR Area		147.09
Consumed FAR (Factor)		0.07
Balance FAR Area		3060.81
BUILT UP AREA CHECK		
Total Proposed BuiltUp Area		147.09
ARCHITECT (Regd)	RAJESH KUMAR	
ENGINEER (Regd)		
SUPERVISOR (Regd)		
OWNER (Regd)	RAJENDRA EKKA	
DEVELOPMENT AUTHORITY		LOCAL BODY

COLOR INDEX	
PLOT BOUNDARY	Black
ABUTTING ROAD	Green
PROPOSED CONSTRUCTION	Red
COMMON PLOT	Yellow
ROAD WIDENING AREA	Orange
EXISTING (To be retained)	Blue
EXISTING (To be demolished)	Light Blue

Buildingwise Floor FAR Details

Floor Name	Building Name A1 (RESIDENCE)		Total	
	Proposed Built Up Area (Sq.mt.)	Proposed FAR Area (Sq.mt.)	Total Proposed Built Up Area (Sq.mt.)	Total FAR Area (Sq.mt.)
Ground Floor	147.09	147.09	147.09	147.09
Terrace Floor	0.00	0.00	0.00	0.00
Total	147.09	147.09	147.09	147.09

Building USE/SUBUSE Details

Building Name	Building Use	Building SubUse	Building Structure
A1 (RESIDENCE)	Residential	Bungalow/ Dwelling / Non Apartment	Non-Highrise

LTP NAME AND SIGNATURE	STRUCTURAL ENG'S NAME AND SIGNATURE	BUILDER NAME AND SIGNATURE	DIGITAL SIGNATURE
RAJESH KUMAR SINPC/DFTMN/0006/2017			

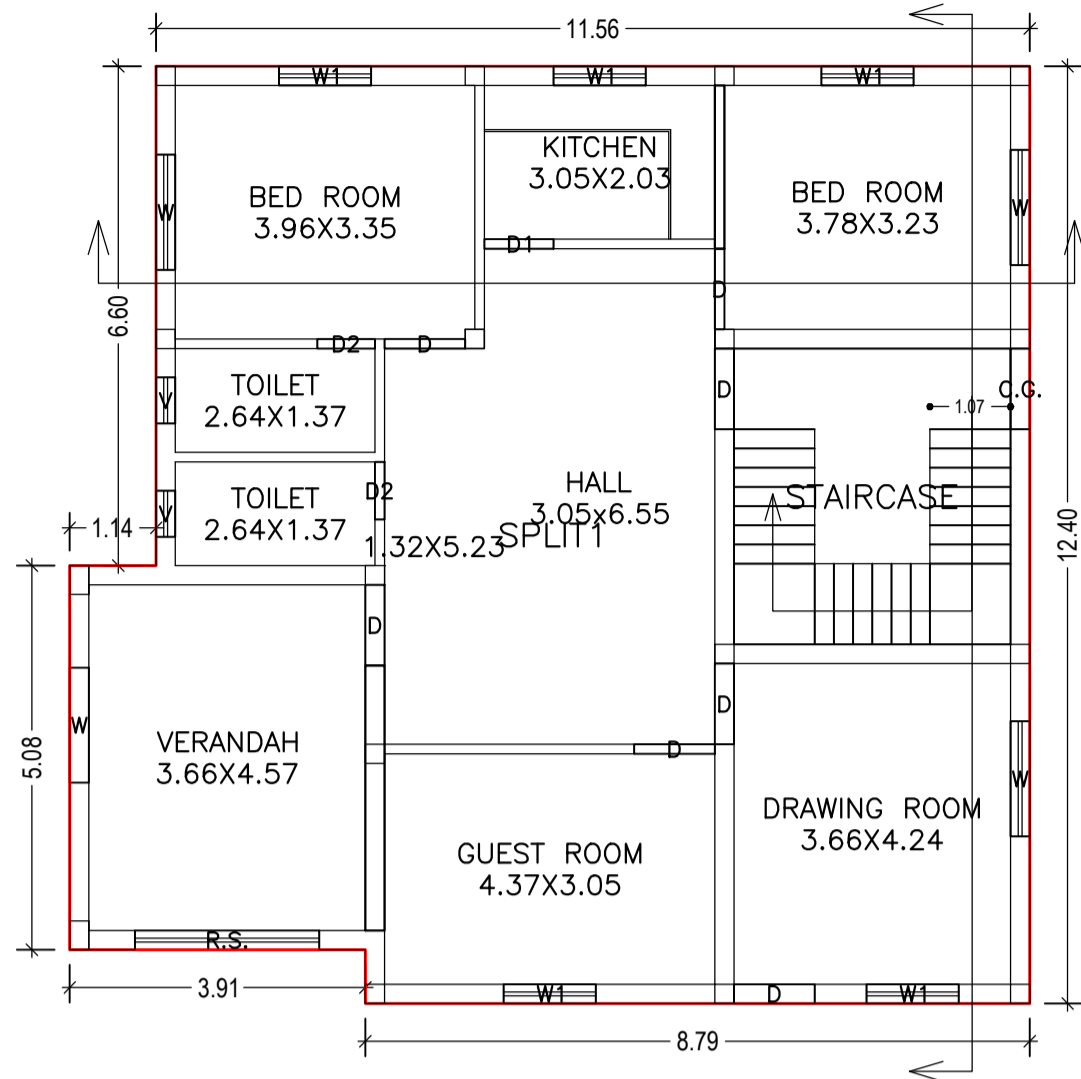

GROUND FLOOR PLAN (Proposed) (SCALE 1:100)

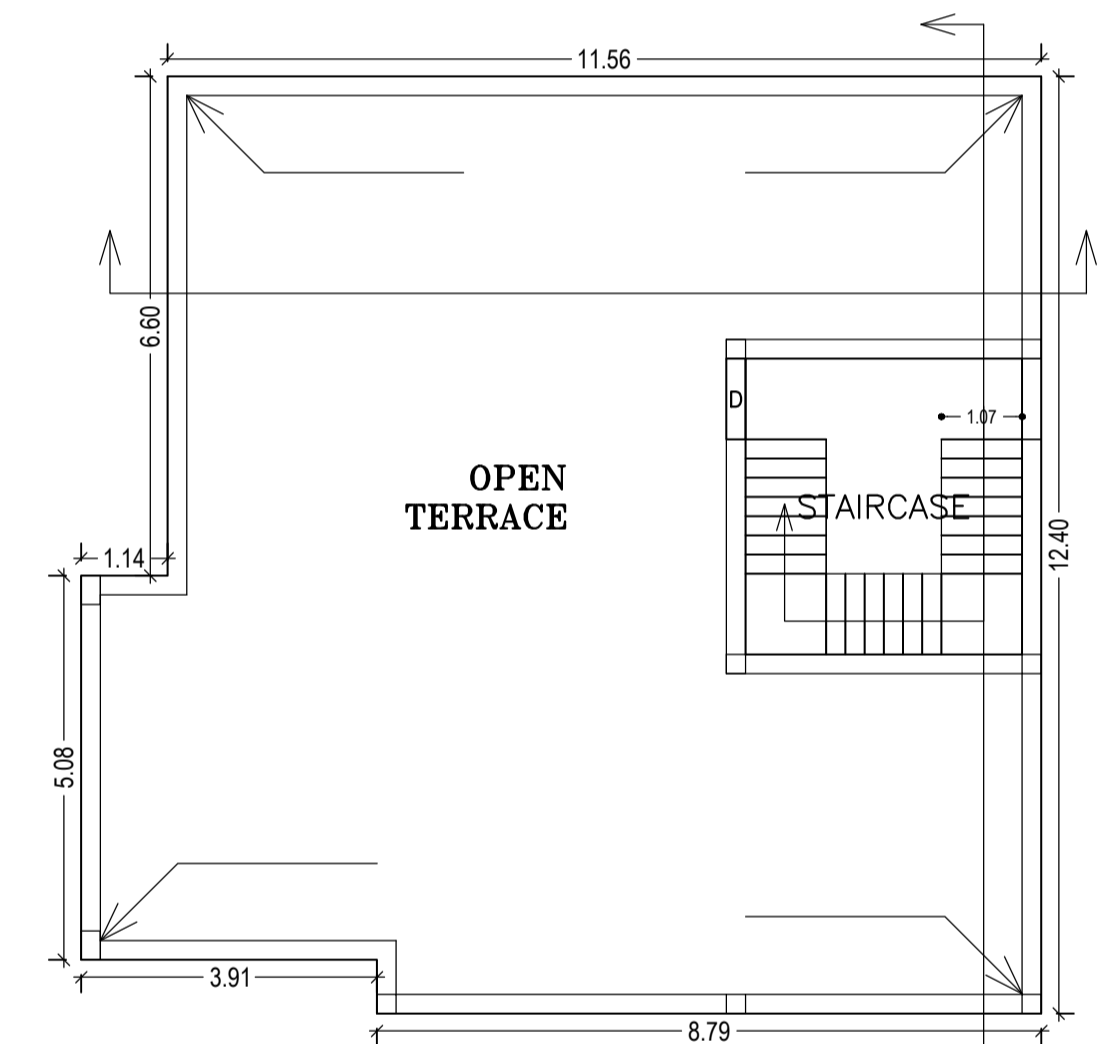

TERRACE FLOOR PLAN (SCALE 1:100)

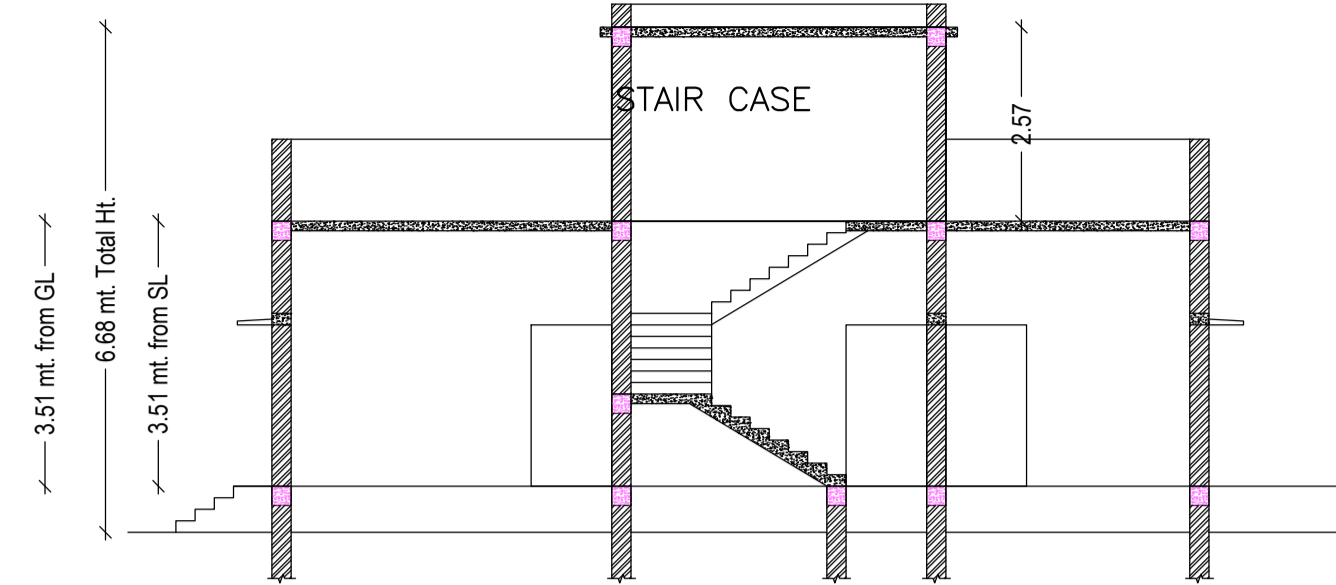

SECTION AT: Y-Y SCALE 1:100

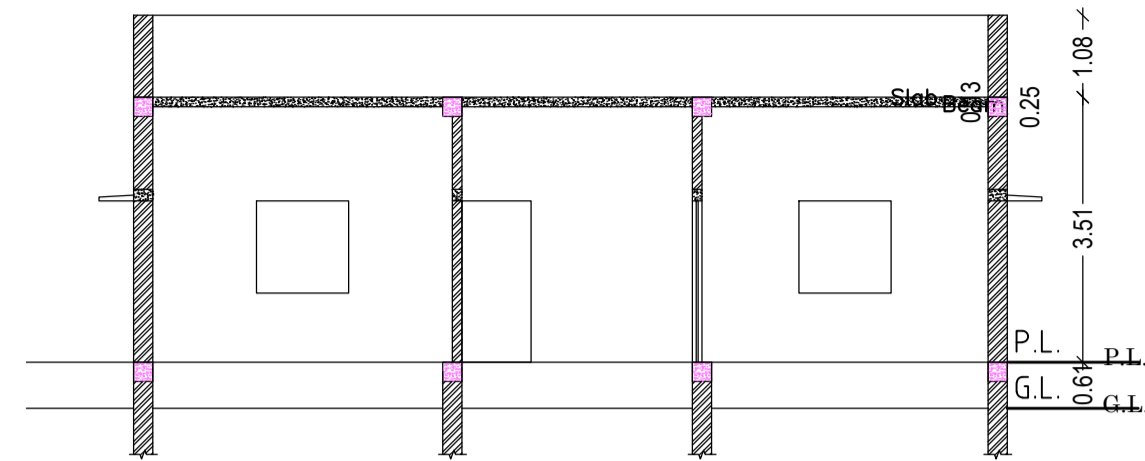

SECTION AT: X-X SCALE 1:100

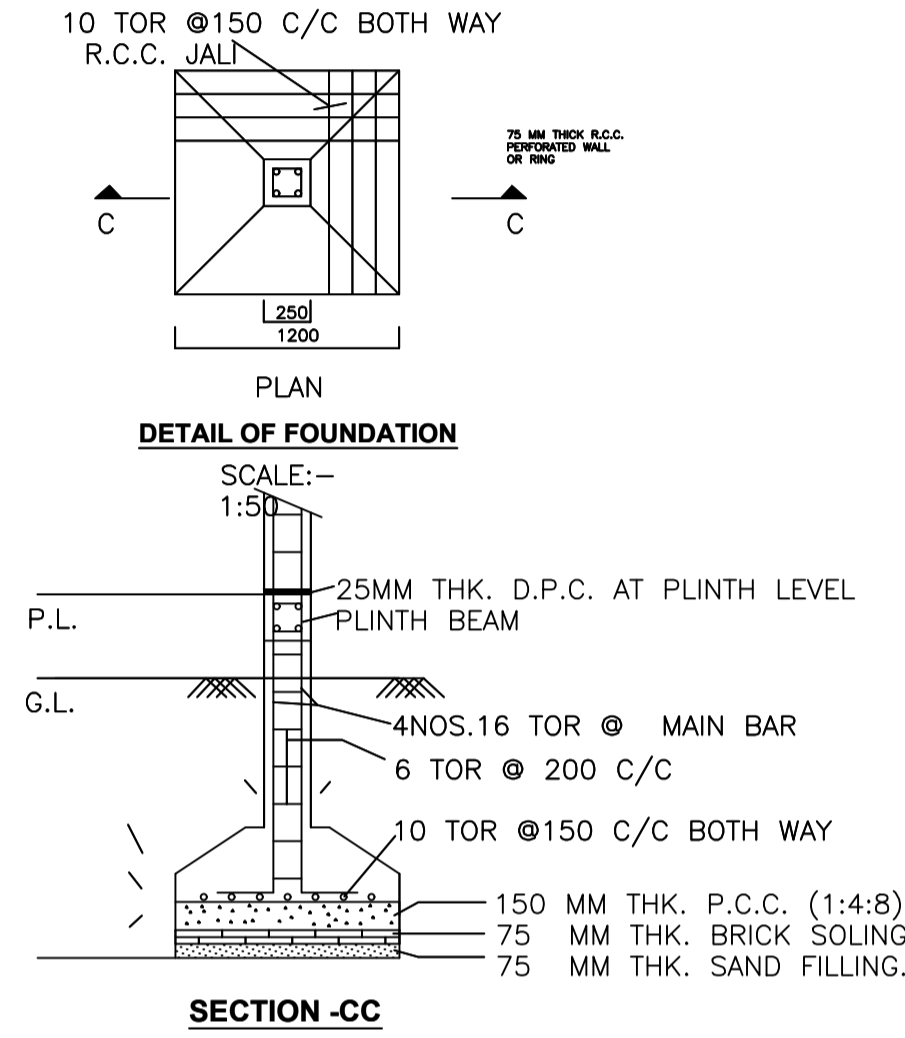
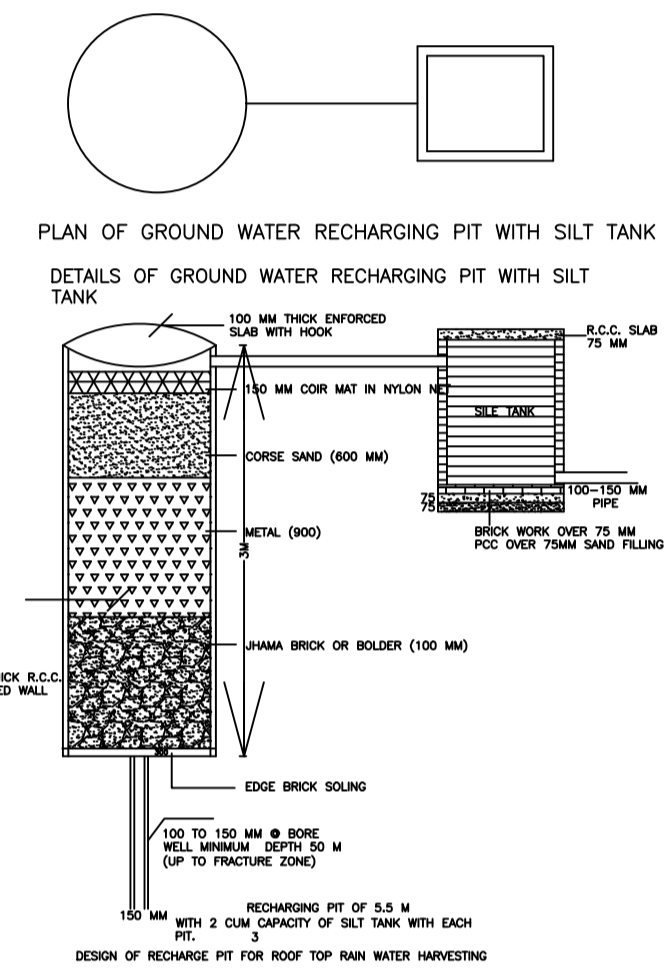

SECTION -CC

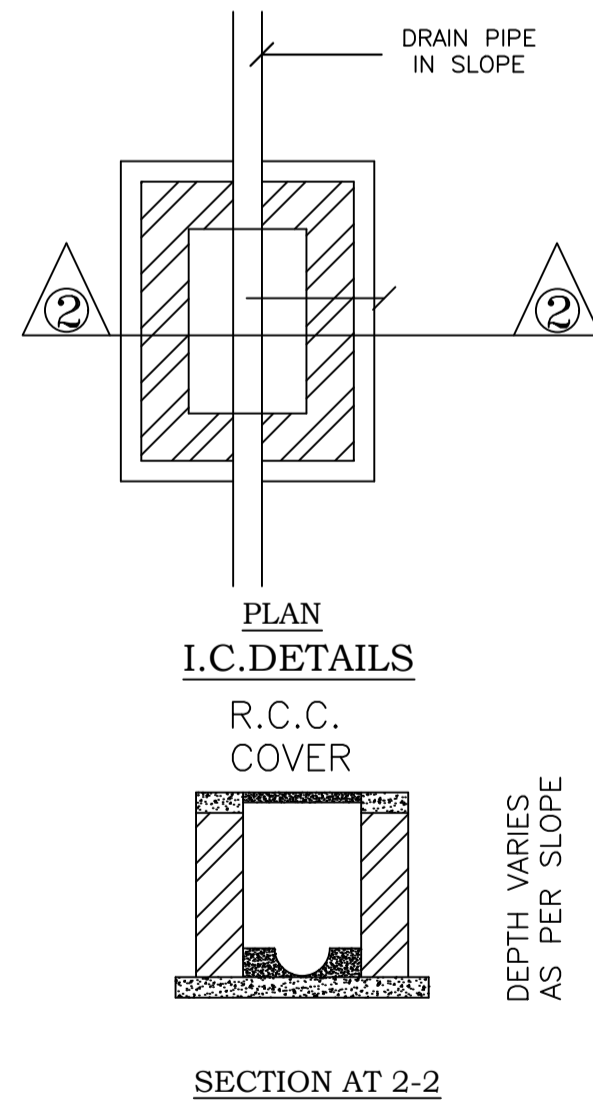

SECTION AT 2-2

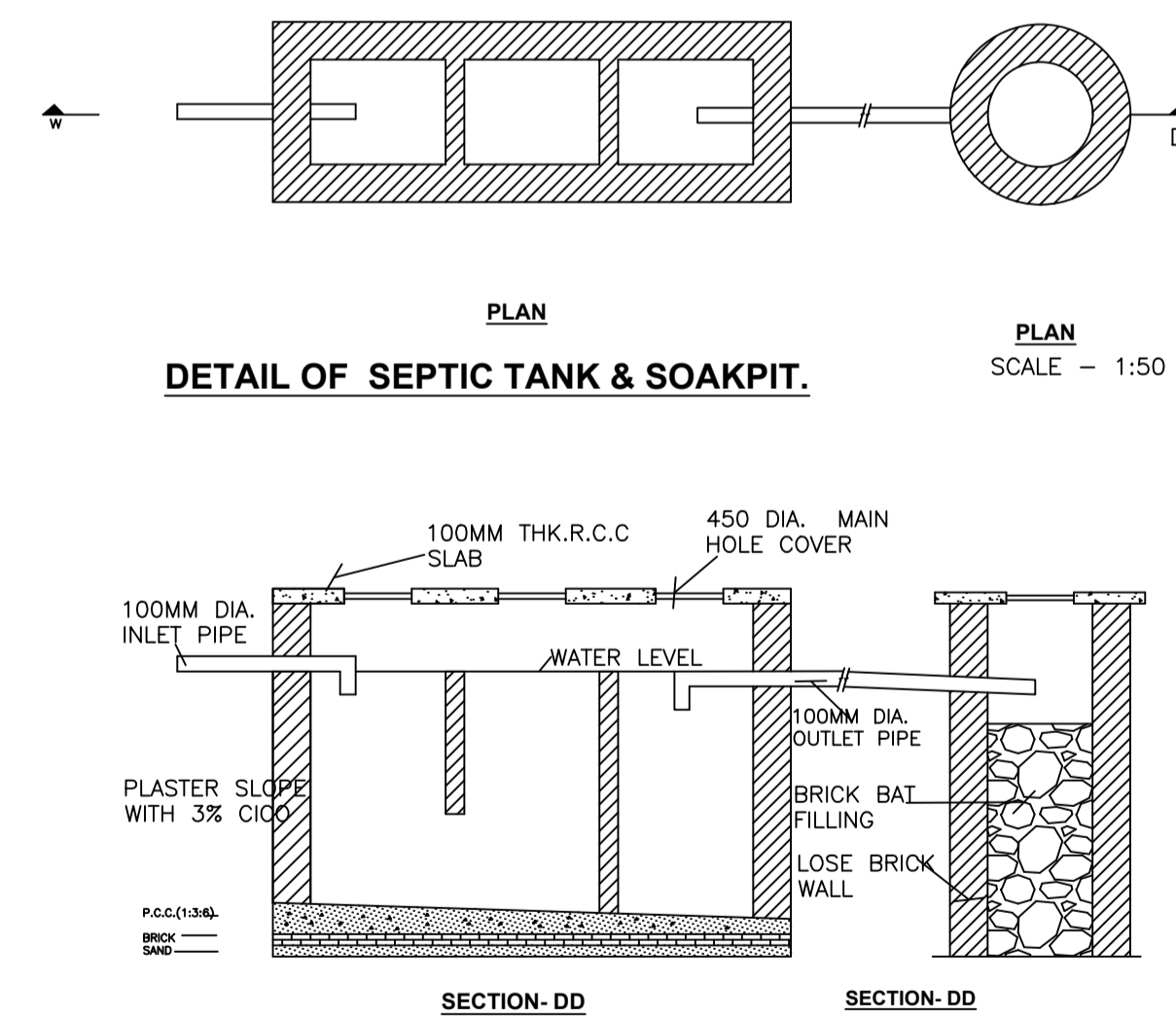

SECTION-DD

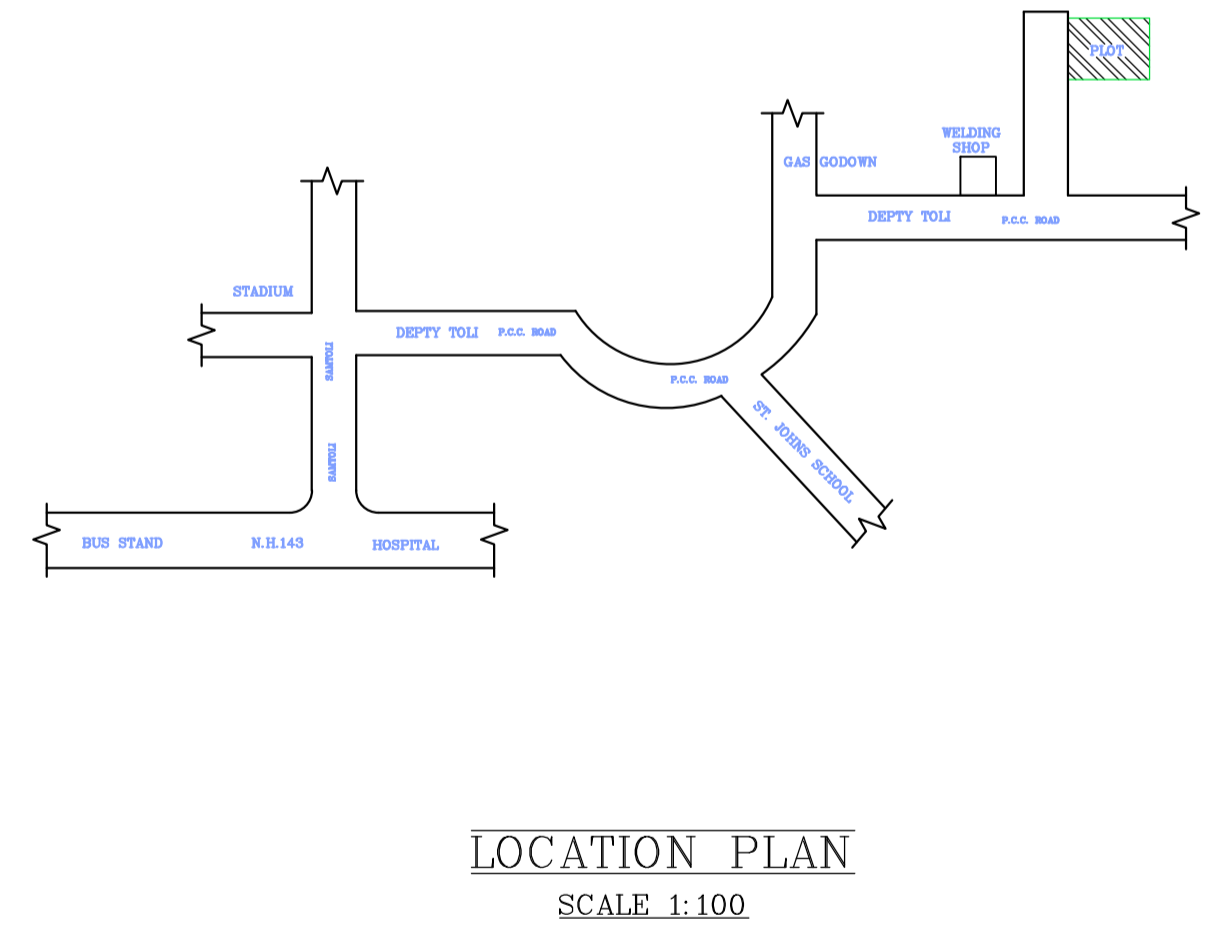

LOCATION PLAN SCALE 1:100

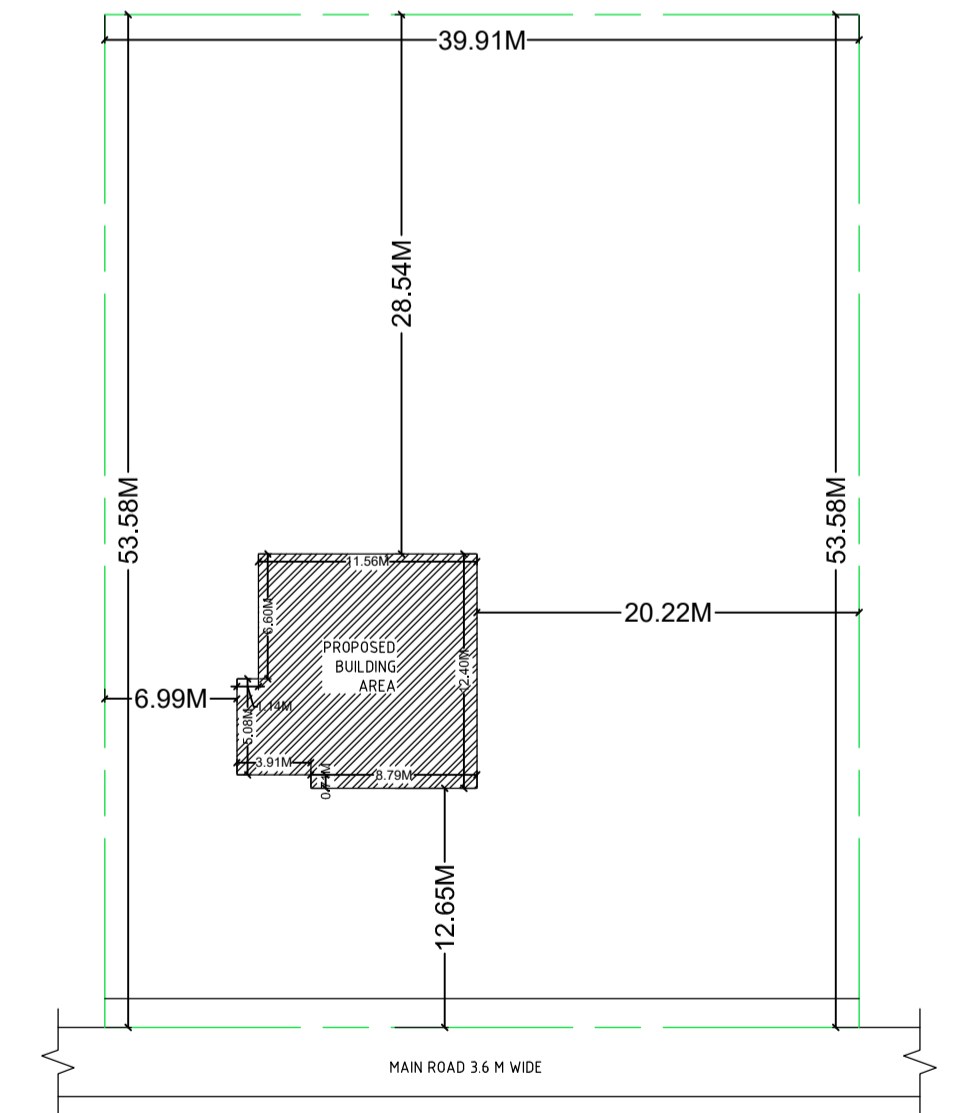

KEY PLAN SCALE 1:400



FRONT ELEVATION SCALE 1:100

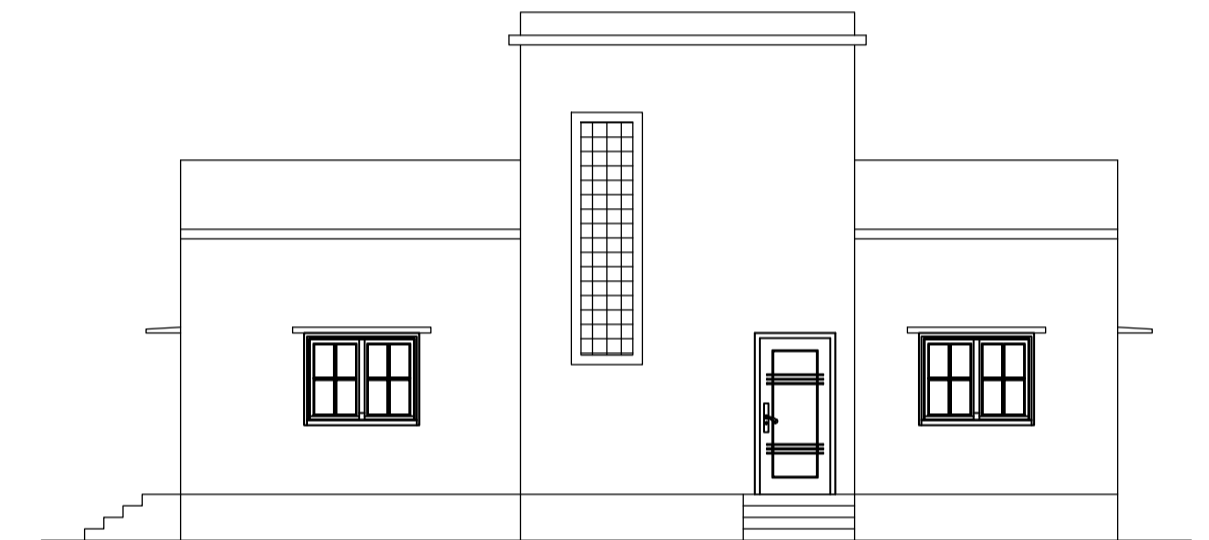

RIGHT SIDE ELEVATION SCALE 1:100

Building :A1 (RESIDENCE)

Floor Name	Total Built Up Area (Sq.mt.)	Proposed FAR Area (Sq.mt.)	Total FAR Area (Sq.mt.)	Total Consumed Additional FAR Area (Sq.mt.)	Tnmt (No.)
Ground Floor	147.09	147.09	147.09	147.09	01
Terrace Floor	0.00	0.00	0.00	0.00	00
Total:	147.09	147.09	147.09	147.09	01
Total Number of Same Buildings	1				
Total:	147.09	147.09	147.09	147.09	01

SCHEDULE OF DOOR:

BUILDING NAME	NAME	LENGTH	HEIGHT	NOS
A1 (RESIDENCE)	D2	0.76	2.10	02
A1 (RESIDENCE)	D1	0.91	2.10	01
A1 (RESIDENCE)	D	1.07	2.10	07
A1 (RESIDENCE)	R.S.	2.44	2.10	01

SCHEDULE OF WINDOW/VENTILATION:

BUILDING NAME	NAME	LENGTH	HEIGHT	NOS
A1 (RESIDENCE)	V	0.61	1.20	02
A1 (RESIDENCE)	W1	1.22	1.20	05
A1 (RESIDENCE)	W	1.52	1.20	04

UnitBUA Table for Building :A1 (RESIDENCE)

FLOOR	Name	UnitBUA Type	UnitBUA Area	Carpet Area	No. of Rooms	No. of Tenement
GROUND FLOOR PLAN	SPLIT1	FLAT	117.31	116.15	9	1
Total:	-	-	117.31	116.15	9	1

LTP NAME AND SIGNATURE	STRUCTURAL ENG'S NAME AND SIGNATURE	BUILDER NAME AND SIGNATURE	DIGITAL SIGNATURE
RAJESH KUMAR SINPC/DFTMN/0006/2017			