

FAR & Tenement Details (Table 4c-1)

Building	No. of Same Bldg	Total Built Up Area (Sq.mt.)	Proposed FAR Area (Sq.mt.) Resi.	Total FAR Area (Sq.mt.)	Total Consumed Additional FAR Area (Sq.mt.)	Tnmt (No.)
A1 (RESIDENCE)	1	118.58	118.58	118.58	118.58	01
Grand Total	1	118.58	118.58	118.58	118.58	01

Proposal Basic Information

Proposal File No.	SINPC/DFTMN/0177/W02/2020
Owner Name	SHANTIMANI MINJ
Khata No	266
Plot No	4117
Village Name	Gotra
Use	Residential
SubUse	Bungalow/ Dwelling / Non Apartment

AREA STATEMENT SIMDEGA NAGAR PANCHAYAT		VERSION NO. : 1.0.46
PROJECT DETAIL		VERSION DATE: 22/06/2020
Region: JHARKHAND URBAN LOCAL BODIES	Plot Use: Residential	
District: SIMDEGA	Plot SubUse: Bungalow/ Dwelling / Non Apartment	
Authority: SIMDEGA NAGAR PANCHAYAT	PlotNearbyReligiousStructure: NA	
Inward No: SINPC/DFTMN/0177/W02/2020	PlotSubPlot No: 4117	
Application Type: General Proposal	North: -	
Project Type: Building Permission	South: -	
Nature of Development: New	East: -	
Location of Development Area: Old Area	West: -	
AREA DETAILS:		
AREA OF PLOT (Minimum)	(A)	SQ.MT. 1248.63
Deduction for NetPlot Area		
Surrender Free of Cost		48.67
Total		48.67
NET AREA OF PLOT(Gross Plot Area - Deduction from Gross Plot area)		
(A-Deductions)		1199.96
Deduction for Balance Plot Area(from Gross Plot Area)		
Surrender Free of Cost		48.67
Common Plot		65.83
Total		114.50
BALANCE AREA OF PLOT(Net Plot Area - Recreational/Amenity space)		
(A-Deductions)		1134.13
PLOT AREA FOR COVERAGE(Net Plot Area)		
(A-Deductions)		1199.96
Plot Area for FAR (Net Plot Area + RoadWidening Area)		
(A-Deductions)		1248.63
COVERAGE CHECK		
Permissible Coverage area ( 50.00 % )		599.98
Proposed Coverage Area ( 9.88 % )		118.58
Total Prop. Coverage Area ( 9.88 % )		118.58
Balance coverage area ( 40.12 % )		481.40
FAR CHECK		
Perm. FAR Area ( 1.50 )		1872.95
Total Perm. FAR area		1872.95
Residential FAR		118.58
Proposed FAR Area		118.58
Total Proposed FAR Area		118.58
Consumed FAR (Factor)		0.09
Balance FAR Area		1754.37
BUILT UP AREA CHECK		
Total Proposed BuiltUp Area		118.58
ARCHITECT (Regd)	RAJESH KUMAR	
ENGINEER (Regd)		
SUPERVISOR (Regd)		
OWNER (Regd)	SHANTIMANI MINJ	
DEVELOPMENT AUTHORITY		LOCAL BODY

COLOR INDEX	
PLOT BOUNDARY	Black
ABUTTING ROAD	Green
PROPOSED CONSTRUCTION	Red
COMMON PLOT	Yellow
ROAD WIDENING AREA	Blue
EXISTING (To be retained)	Blue
EXISTING (To be demolished)	Yellow

Buildingwise Floor FAR Details

Floor Name	Building Name A1 (RESIDENCE)		Total	
	Proposed Built Up Area (Sq.mt.)	Proposed FAR Area (Sq.mt.)	Total Proposed Built Up Area (Sq.mt.)	Total FAR Area (Sq.mt.)
Ground Floor	118.58	118.58	118.58	118.58
Terrace Floor	0.00	0.00	0.00	0.00
Total	118.58	118.58	118.58	118.58

Building USE/SUBUSE Details

Building Name	Building Use	Building SubUse	Building Structure
A1 (RESIDENCE)	Residential	Bungalow/ Dwelling / Non Apartment	Non-Highrise

SITE PLAN

LTP NAME AND SIGNATURE	STRUCTURAL ENG'S NAME AND SIGNATURE	BUILDER NAME AND SIGNATURE	DIGITAL SIGNATURE
RAJESH KUMAR SINPC/DFTMN/0006/2017			

Proposal Basic Information	
Proposal File No.	SINPC/0177/W02/2020
Owner Name	SHANTIMANI MINJ
Khata No	266
Plot No	4117
Village Name	Gotra
Use	Residential
SubUse	Bungalow/ Dwelling / Non Apartment

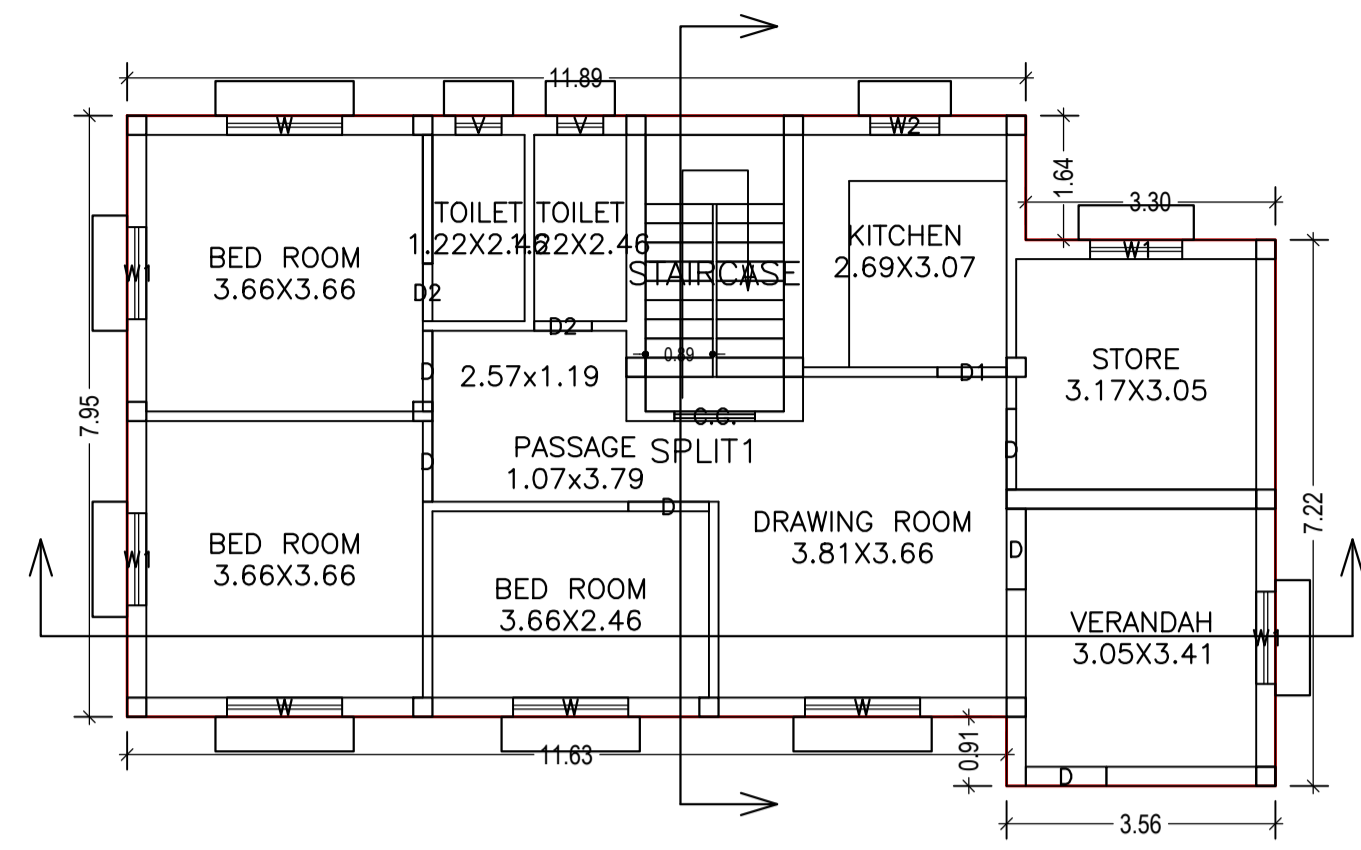

GROUND FLOOR PLAN (Proposed) (SCALE 1:100)

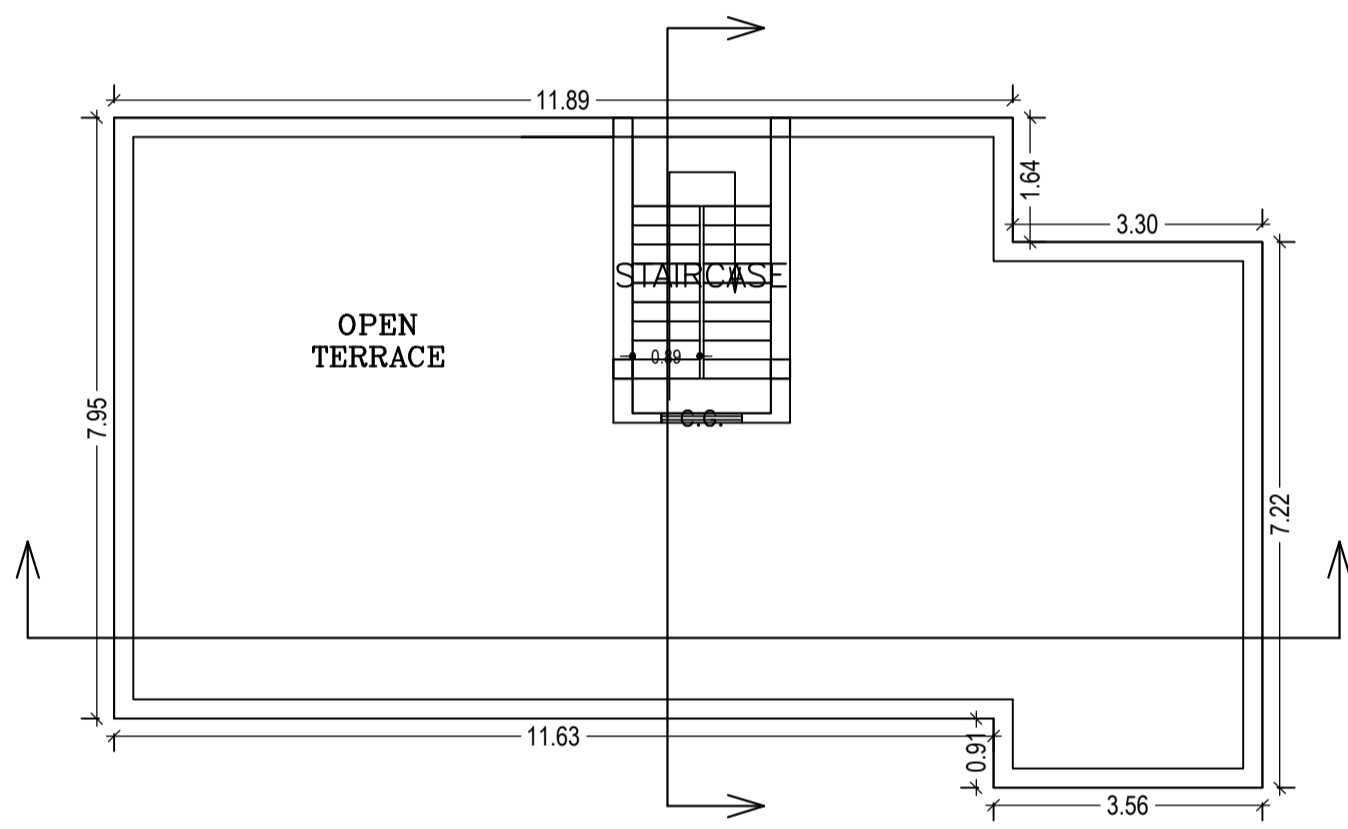

TERRACE FLOOR PLAN (SCALE 1:100)

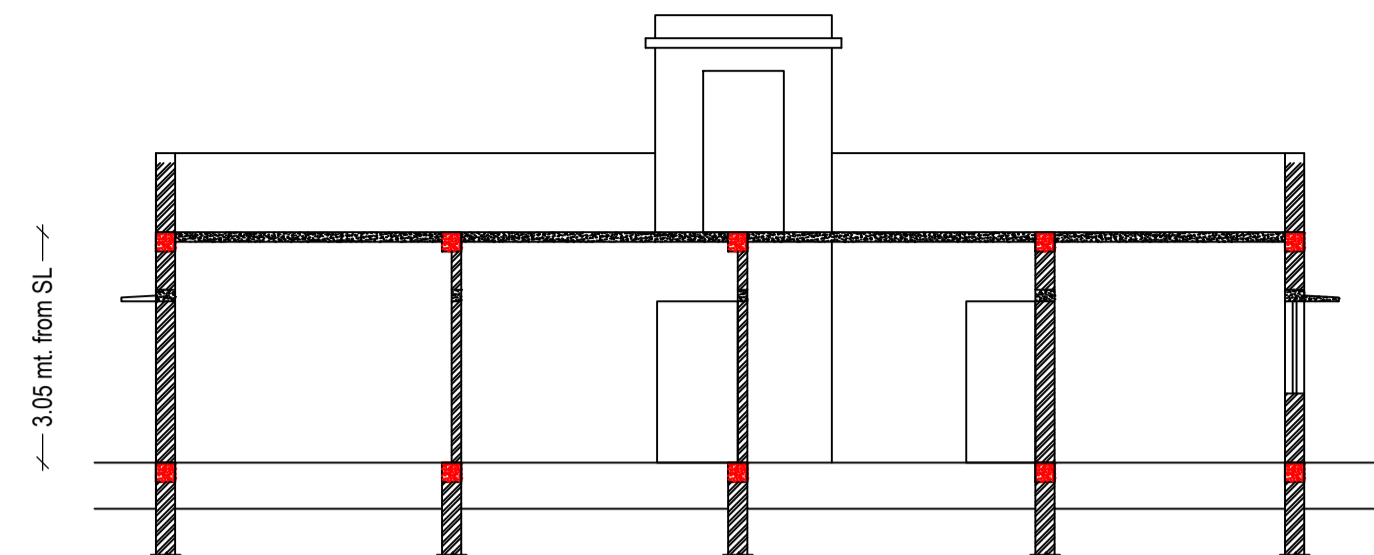

SECTION AT: Y-Y SCALE 1:100

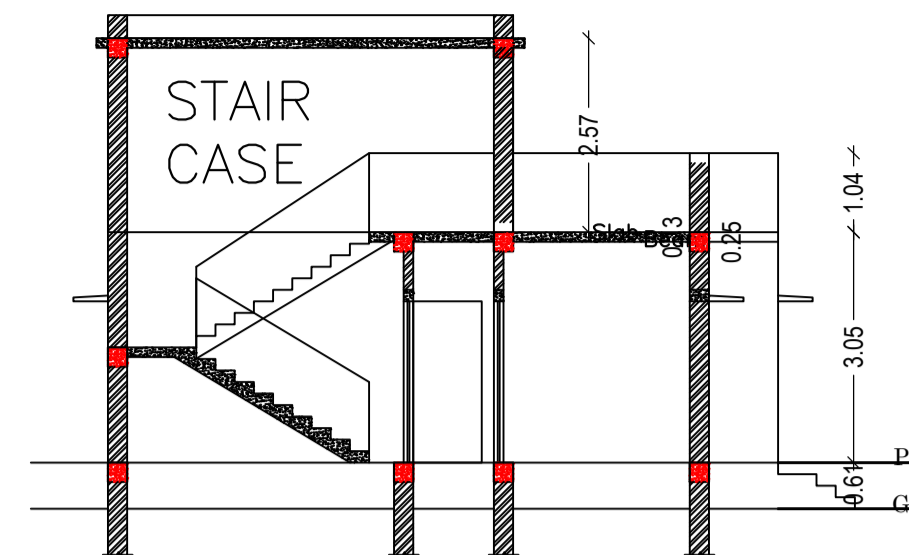

SECTION AT: X-X SCALE 1:100

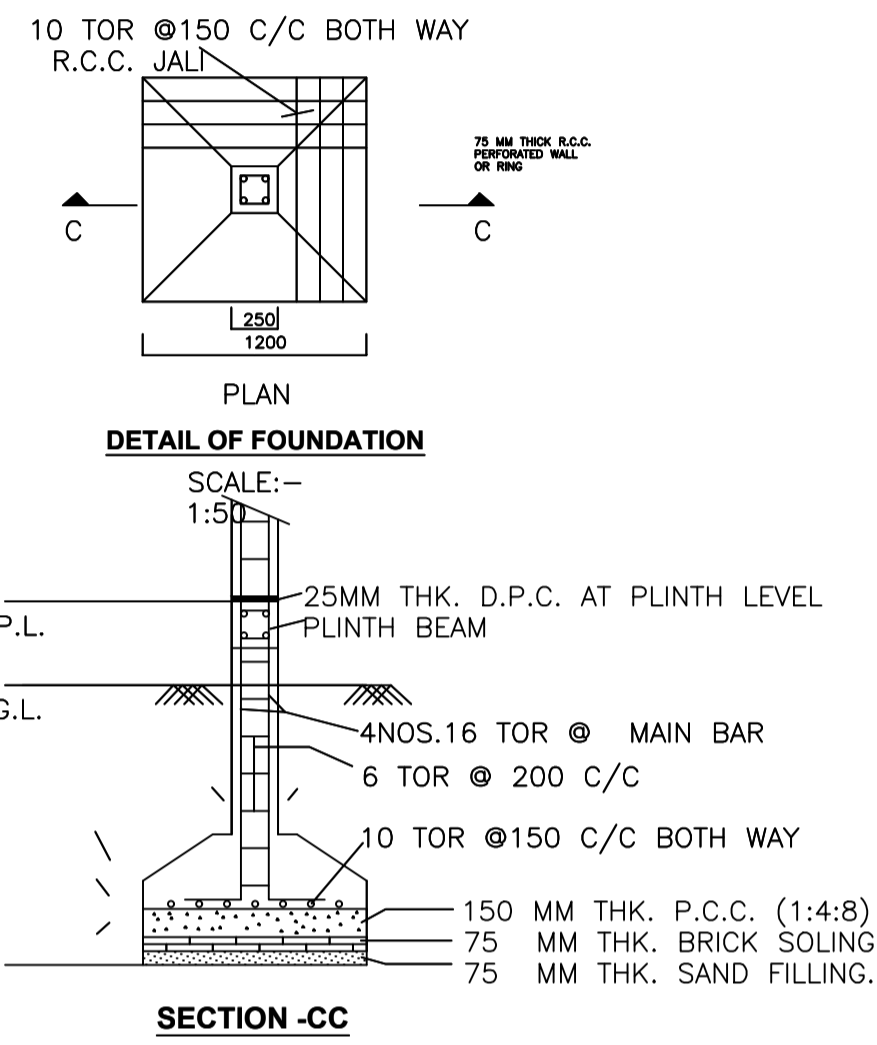

SECTION -CC

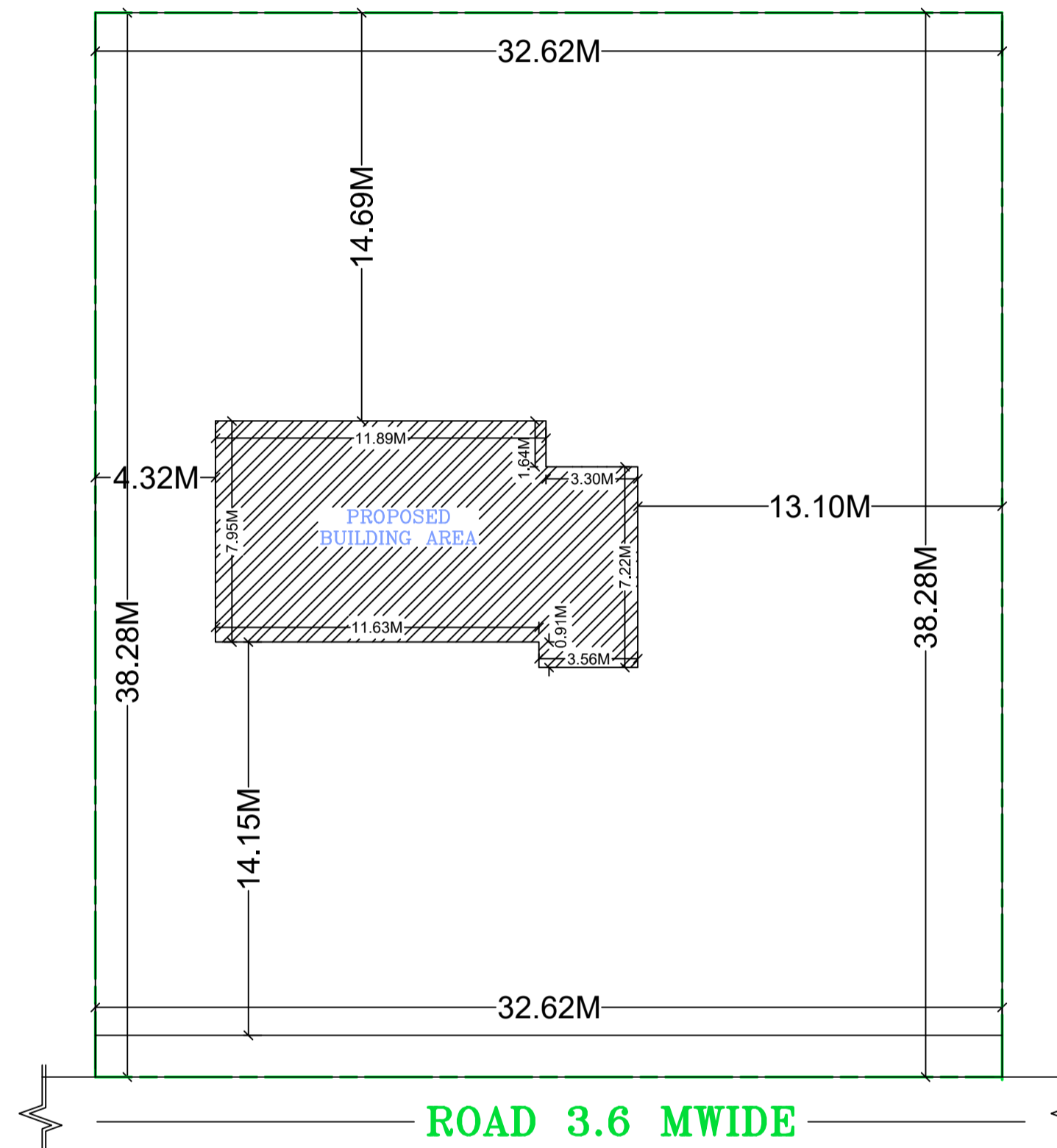

KEY PLAN SCALE 1:200

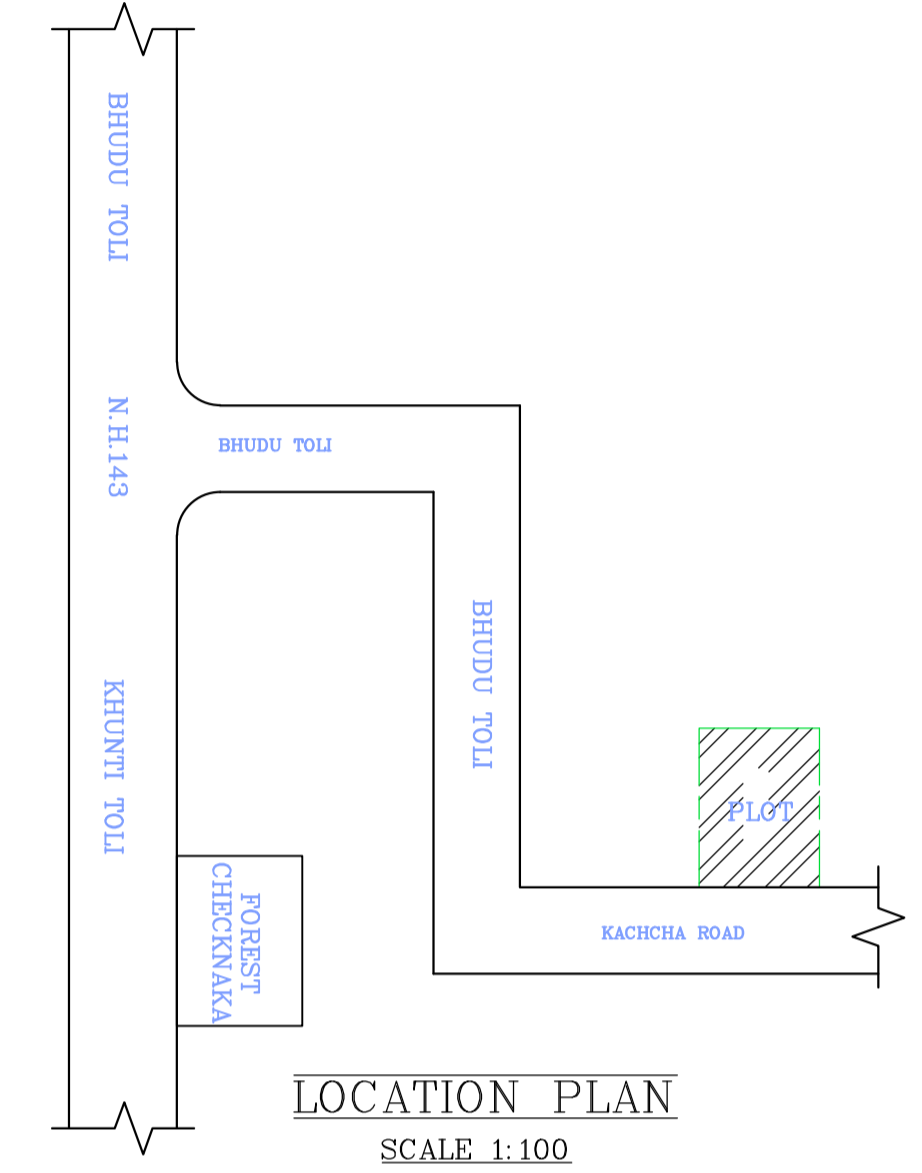

LOCATION PLAN SCALE 1:100

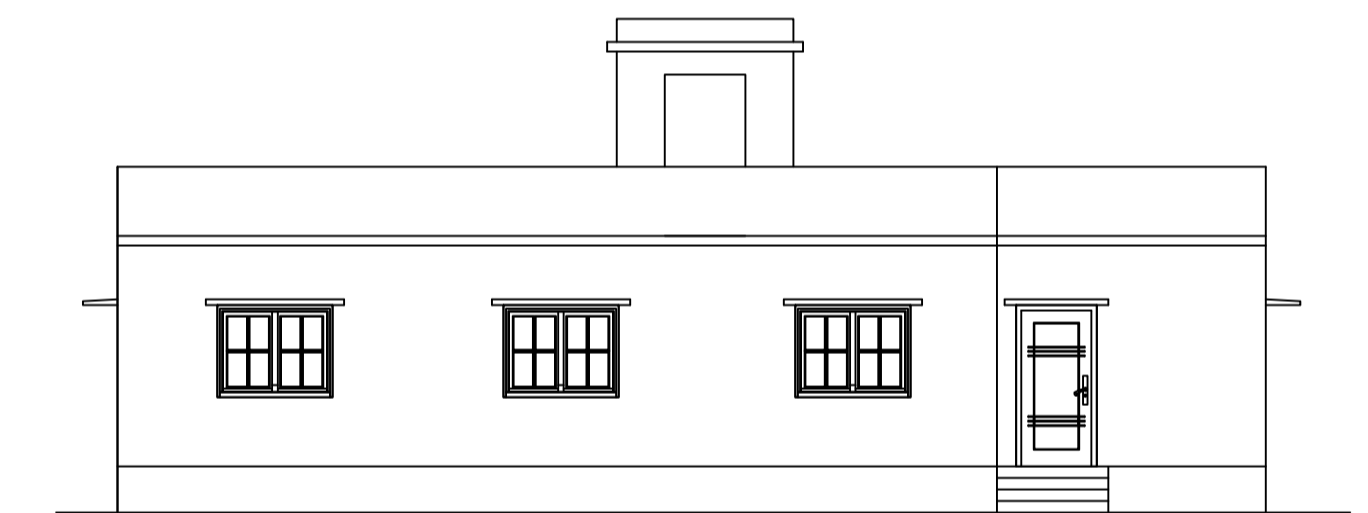

FRONT ELEVATION SCALE 1:100



LEFT SIDE ELEVATION SCALE 1:100

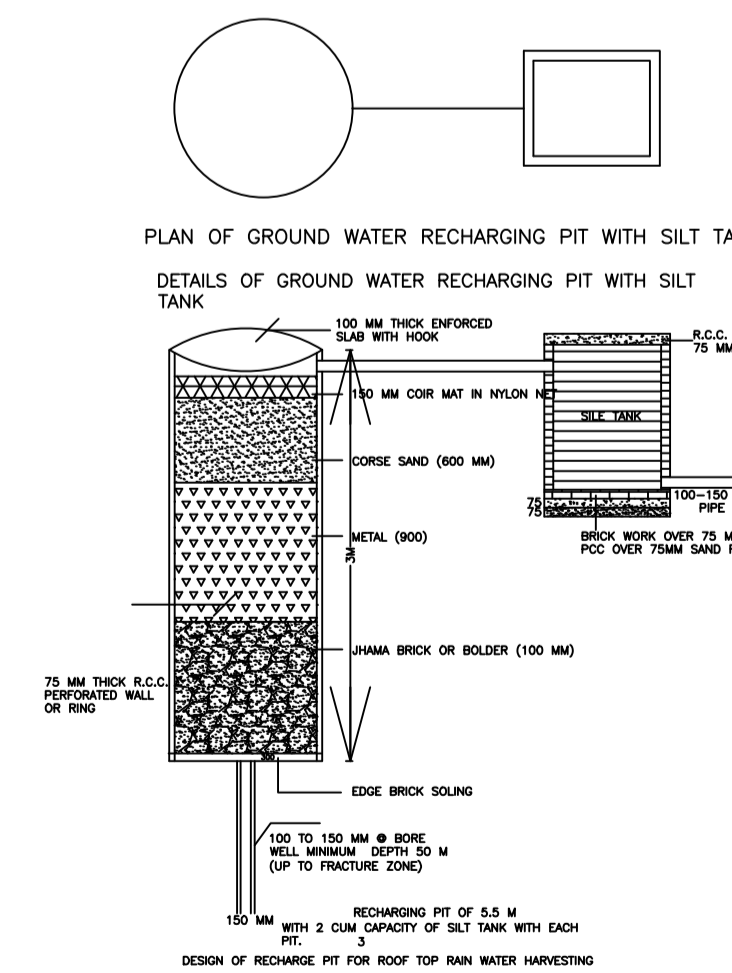

Building :A1 (RESIDENCE)					
Floor Name	Total Built Up Area (Sq.mt.)	Proposed FAR Area (Sq.mt.)	Total FAR Area (Sq.mt.)	Total Consumed Additional FAR Area (Sq.mt.)	Tnmt (No.)
Ground Floor	118.58	118.58	118.58	118.58	01
Terrace Floor	0.00	0.00	0.00	0.00	00
Total :	118.58	118.58	118.58	118.58	01
Total Number of Same Buildings	1				
Total :	118.58	118.58	118.58	118.58	01

SCHEDULE OF DOOR:

BUILDING NAME	NAME	LENGTH	HEIGHT	NOS
A1 (RESIDENCE)	D2	0.76	2.10	02
A1 (RESIDENCE)	D1	0.91	2.10	01
A1 (RESIDENCE)	D	1.07	2.10	06
A1 (RESIDENCE)	C.G.	1.07	2.10	01

SCHEDULE OF WINDOW/VENTILATION:

BUILDING NAME	NAME	LENGTH	HEIGHT	NOS
A1 (RESIDENCE)	V	0.61	1.20	02
A1 (RESIDENCE)	W2	0.91	1.20	01
A1 (RESIDENCE)	W1	1.22	1.20	04
A1 (RESIDENCE)	W	1.52	1.20	04

UnitBUA Table for Building :A1 (RESIDENCE)

FLOOR	Name	UnitBUA Type	UnitBUA Area	Carpet Area	No. of Rooms	No. of Tenement
GROUND FLOOR PLAN	SPLIT1	FLAT	97.78	96.72	10	1
Total:	-	-	97.78	96.72	10	1

LTP NAME AND SIGNATURE	STRUCTURAL ENG'S NAME AND SIGNATURE	BUILDER NAME AND SIGNATURE	DIGITAL SIGNATURE
RAJESH KUMAR SINPC/DFTMN/0006/2017			

Proposal Basic Information	
Proposal File No.	SINPC/DFTMN/0177/W02/2020
Owner Name	SHANTIMANI MINJ
Khata No	266
Plot No	4117
Village Name	Gotra
Use	Residential
SubUse	Bungalow/ Dwelling / Non Apartment

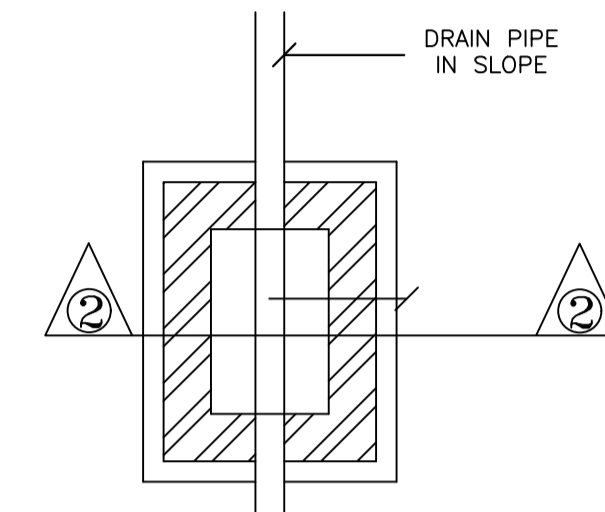

PLAN  
I.C.DETAILS  
R.C.C.  
COVER

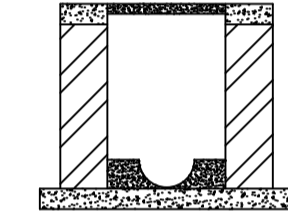

SECTION AT 2-2

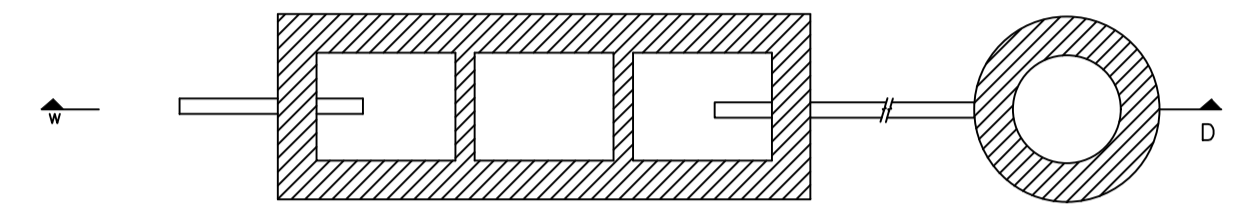

PLAN  
DETAIL OF SEPTIC TANK & SOAKPIT.

PLAN  
SCALE - 1:50

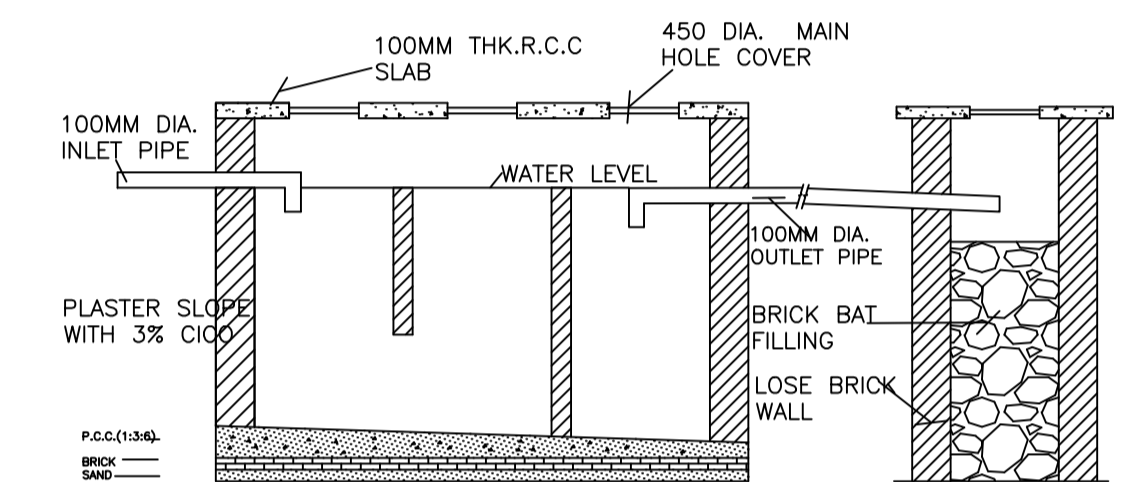

SECTION-DD

SECTION-DD

LTP NAME AND SIGNATURE	STRUCTURAL ENG'S NAME AND SIGNATURE	BUILDER NAME AND SIGNATURE	DIGITAL SIGNATURE
RAJESH KUMAR SINPC/DFTMN/0006/2017			