

SITE PLAN

FAR & Tenement Details (Table 4c-1)

Building	No. of Same Bldg	Total Built Up Area (Sq.mt.)	Proposed FAR Area (Sq.mt.) Resi.	Total FAR Area (Sq.mt.)	Total Consumed Additional FAR Area (Sq.mt.)	Tnmt (No.)
A1 (RESIDENCE)	1	145.29	145.29	145.29	145.29	01
Grand Total	1	145.29	145.29	145.29	145.29	01

Proposal Basic Information

Proposal File No.	SINPC/BP/0170/W02/2020
Owner Name	SHOBHA DEVI
Khata No	101
Plot No	4882
Village Name	Gotra
Use	Residential
SubUse	Bungalow/ Dwelling / Non Apartment

AREA STATEMENT SIMDEGA NAGAR PANCHAYAT		VERSION NO.: 1.0.46	VERSION DATE: 22/06/2020
PROJECT DETAIL:			
Region: JHARKHAND URBAN LOCAL BODIES	Plot Use: Residential		
District: SIMDEGA	Plot SubUse: Bungalow/ Dwelling / Non Apartment		
Authority: SIMDEGA NAGAR PANCHAYAT	PlotNearbyReligiousStructure: NA		
Inward No: SINPC/BP/0170/W02/2020	Plot/SubPlot No: 4882		
Application Type: General Proposal	North: -		
Project Type: Building Permission	South: -		
Nature of Development: New	East: -		
Location of Development Area: Old Area	West: -		
AREA DETAILS:			
AREA OF PLOT (Minimum)	(A)	SQ.MT. 279.24	
Deduction for NetPlot Area			
Surrender Free of Cost		22.93	
Total		22.93	
NET AREA OF PLOT(Gross Plot Area - Deduction from Gross Plot area)			
(A-Deductions)		256.31	
Deduction for Balance Plot Area(from Gross Plot Area)			
Surrender Free of Cost		22.93	
Common Plot		16.34	
Total		39.27	
BALANCE AREA OF PLOT(Net Plot Area - Recreational/Amenity space)			
(A-Deductions)		239.97	
PLOT AREA FOR COVERAGE(Net Plot Area)			
(A-Deductions)		256.31	
Plot Area for FAR (Net Plot Area + RoadWidening Area)			
(A-Deductions)		279.24	
COVERAGE CHECK			
Permissible Coverage area (60.00 %)		153.79	
Proposed Coverage Area (56.68 %)		145.29	
Total Prop. Coverage Area (56.68 %)		145.29	
Balance coverage area (3.32 %)		8.50	
FAR CHECK			
Perm. FAR Area (1.50)		418.86	
Total Perm. FAR area		418.86	
Residential FAR		145.29	
Proposed FAR		145.29	
Total Proposed FAR Area		145.29	
Consumed FAR (Factor)		0.52	
Balance FAR Area		273.57	
BUILT UP AREA CHECK			
Total Proposed BuiltUp Area		145.29	
ARCHITECT (Regd)		RAJESH KUMAR	
ENGINEER (Regd)			
SUPERVISOR (Regd)			
OWNER (Regd)		SHOBHA DEVI	
DEVELOPMENT AUTHORITY		LOCAL BODY	

COLOR INDEX	
PLOT BOUNDARY	Black
ABUTTING ROAD	Green
PROPOSED CONSTRUCTION	Red
COMMON PLOT	Yellow
ROAD WIDENING AREA	Blue
EXISTING (To be retained)	Blue
EXISTING (To be demolished)	Yellow

Buildingwise Floor FAR Details

Floor Name	Building Name A1 (RESIDENCE)		Total	
	Proposed Built Up Area (Sq.mt.)	Proposed FAR Area (Sq.mt.)	Total Proposed Built Up Area (Sq.mt.)	Total FAR Area (Sq.mt.)
Ground Floor	145.29	145.29	145.29	145.29
Terrace Floor	0.00	0.00	0.00	0.00
Total	145.29	145.29	145.29	145.29

Building USE/SUBUSE Details

Building Name	Building Use	Building SubUse	Building Structure
A1 (RESIDENCE)	Residential	Bungalow/ Dwelling / Non Apartment	Non-Highrise

LTP NAME AND SIGNATURE	STRUCTURAL ENG'S NAME AND SIGNATURE	BUILDER NAME AND SIGNATURE	DIGITAL SIGNATURE
RAJESH KUMAR SINPC/DFTMN/0006/2017			

Proposal Basic Information	
Proposal File No.	SINPC/BP/0170/W02/2020
Owner Name	SHOBHA DEVI
Khata No	101
Plot No	4882
Village Name	Gotra
Use	Residential
SubUse	Bungalow/ Dwelling / Non Apartment

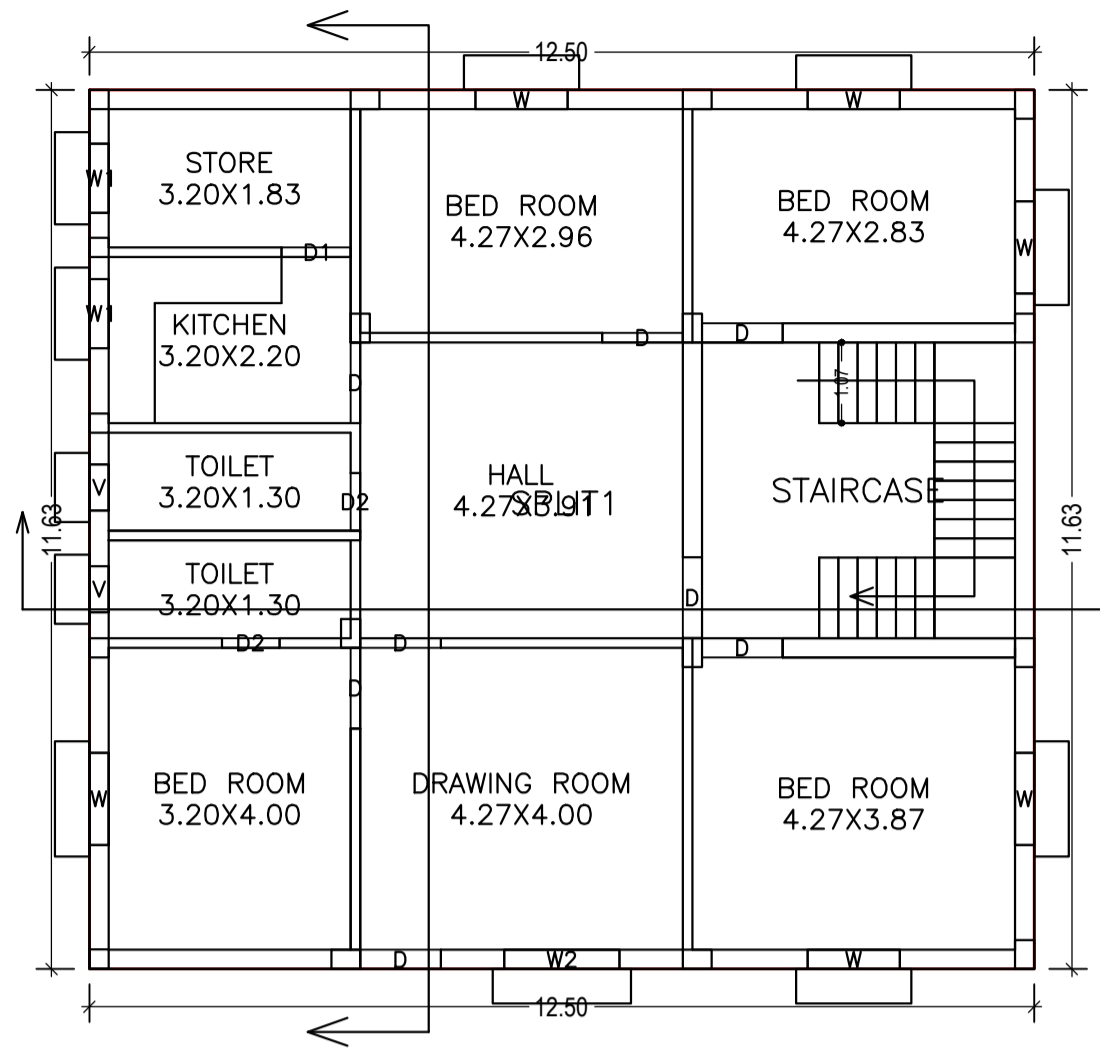

GROUND FLOOR PLAN (Proposed) (SCALE 1:100)

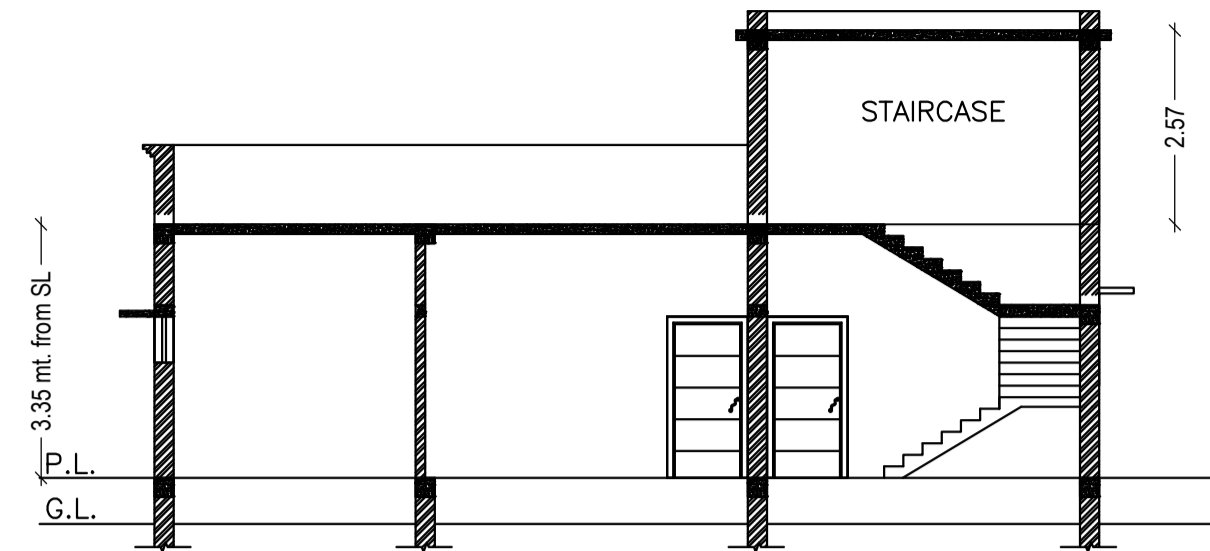

SECTION AT: X-X SCALE 1:100

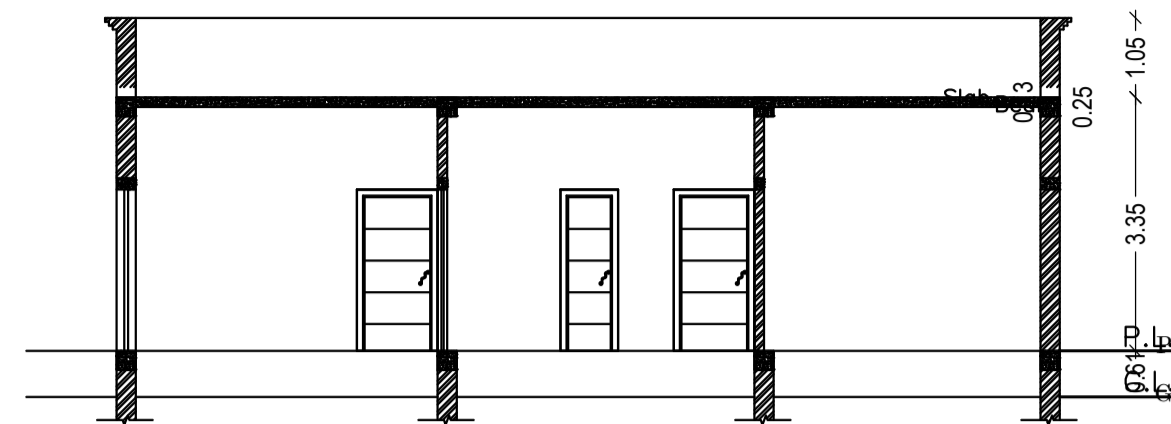

SECTION AT: Y-Y SCALE 1:100

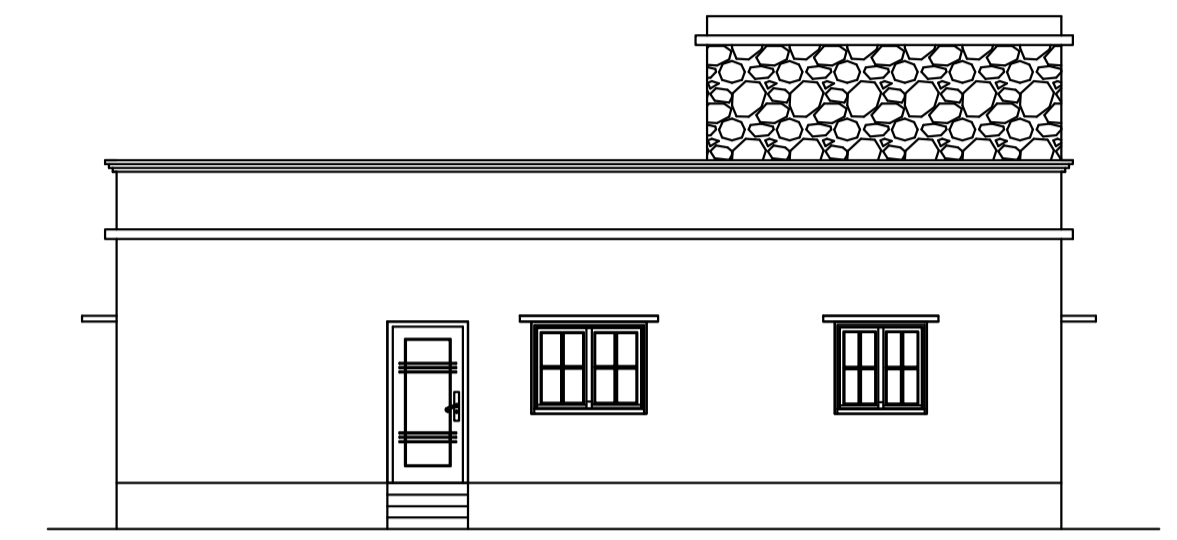
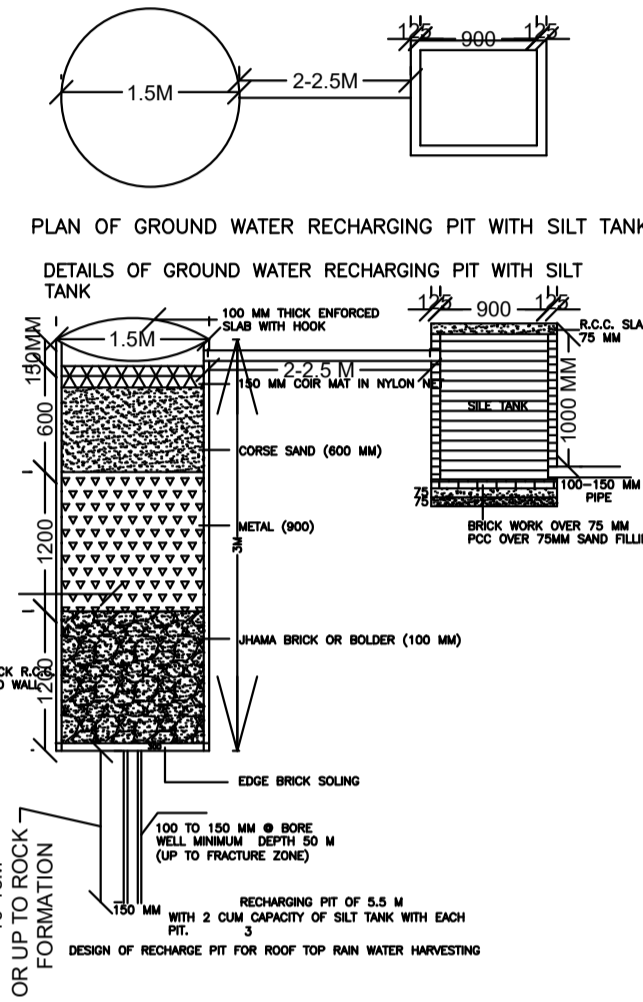

FRONT ELEVATION SCALE 1:100

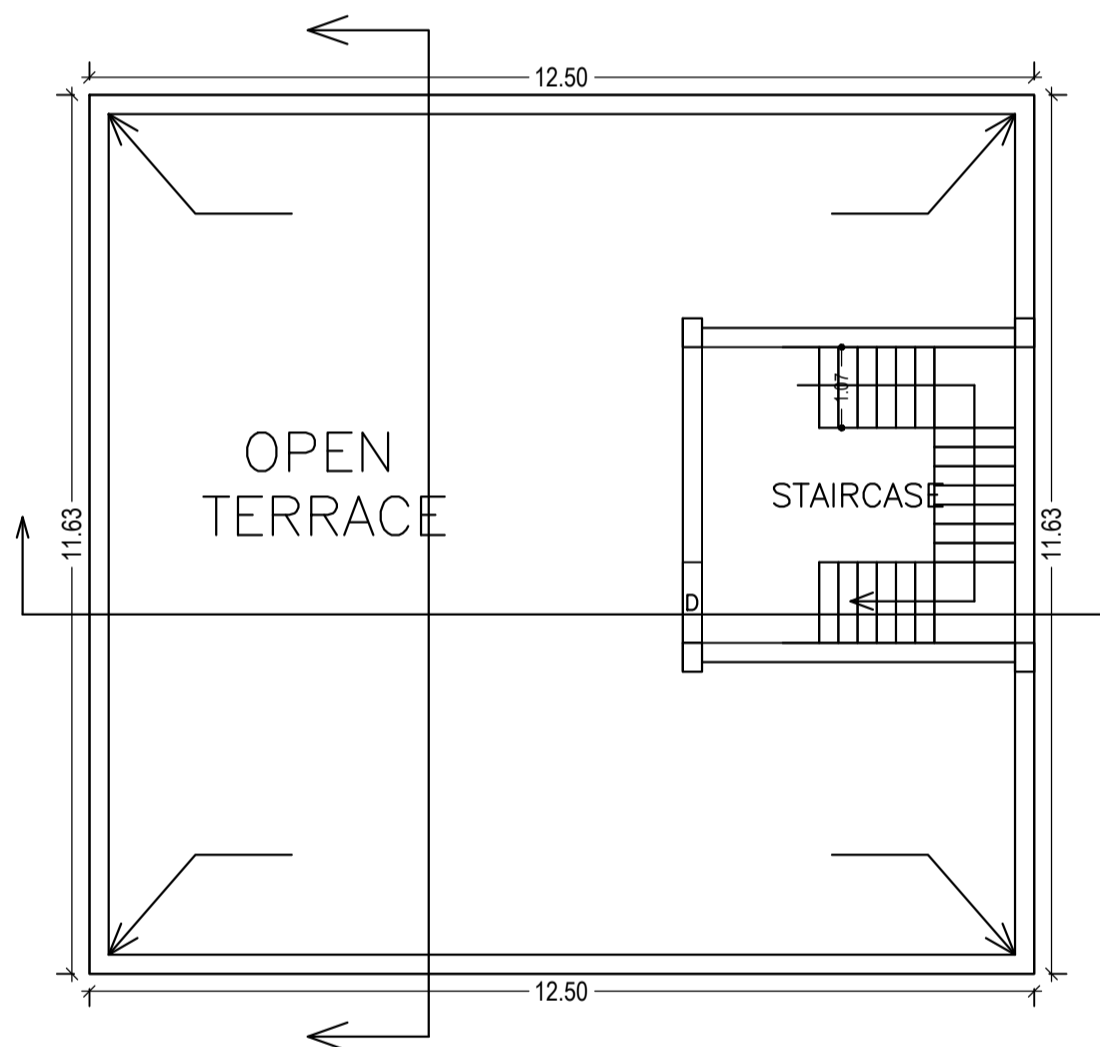

TERRACE FLOOR PLAN (SCALE 1:100)

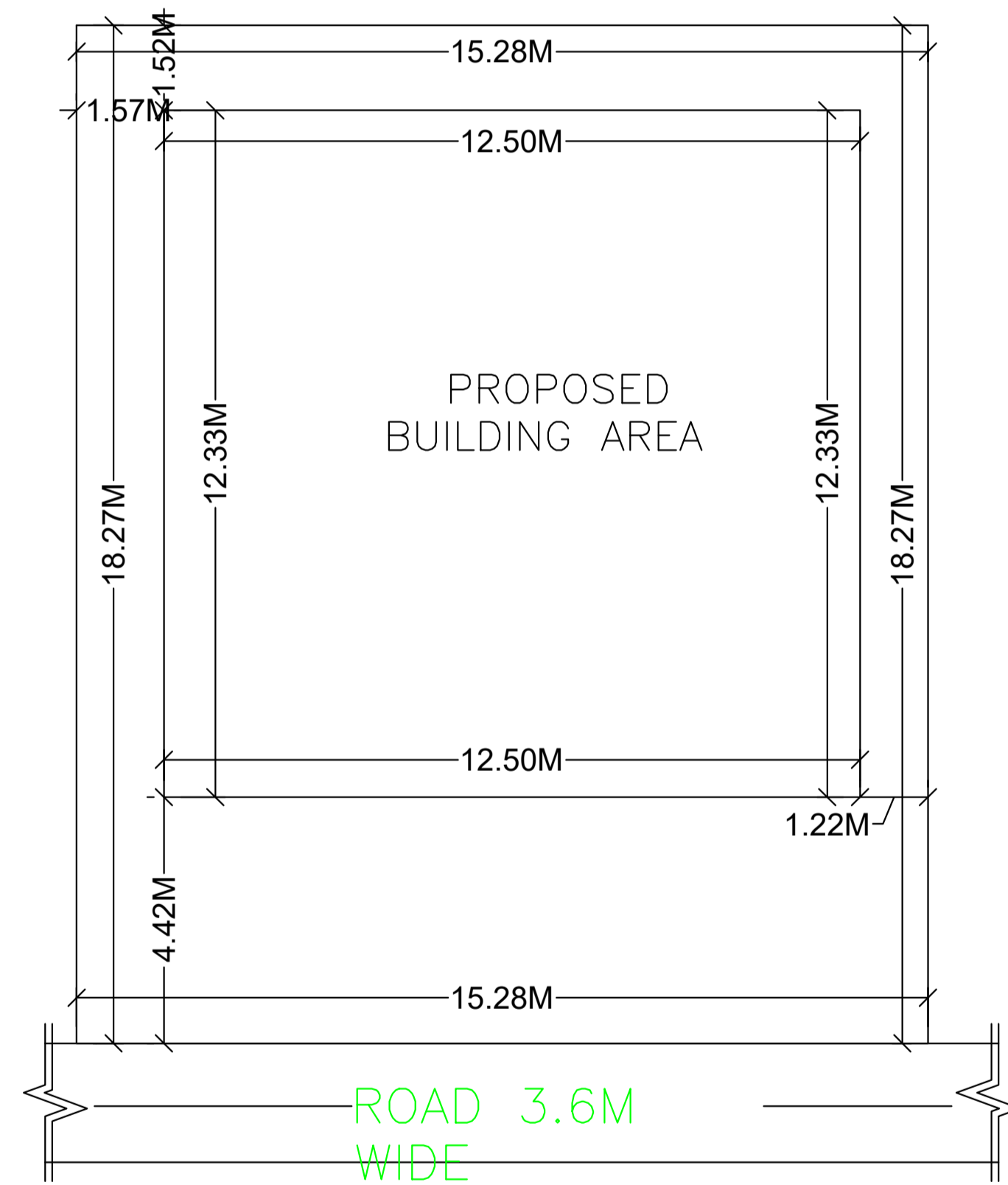

KEY PLAN SCALE 1:100

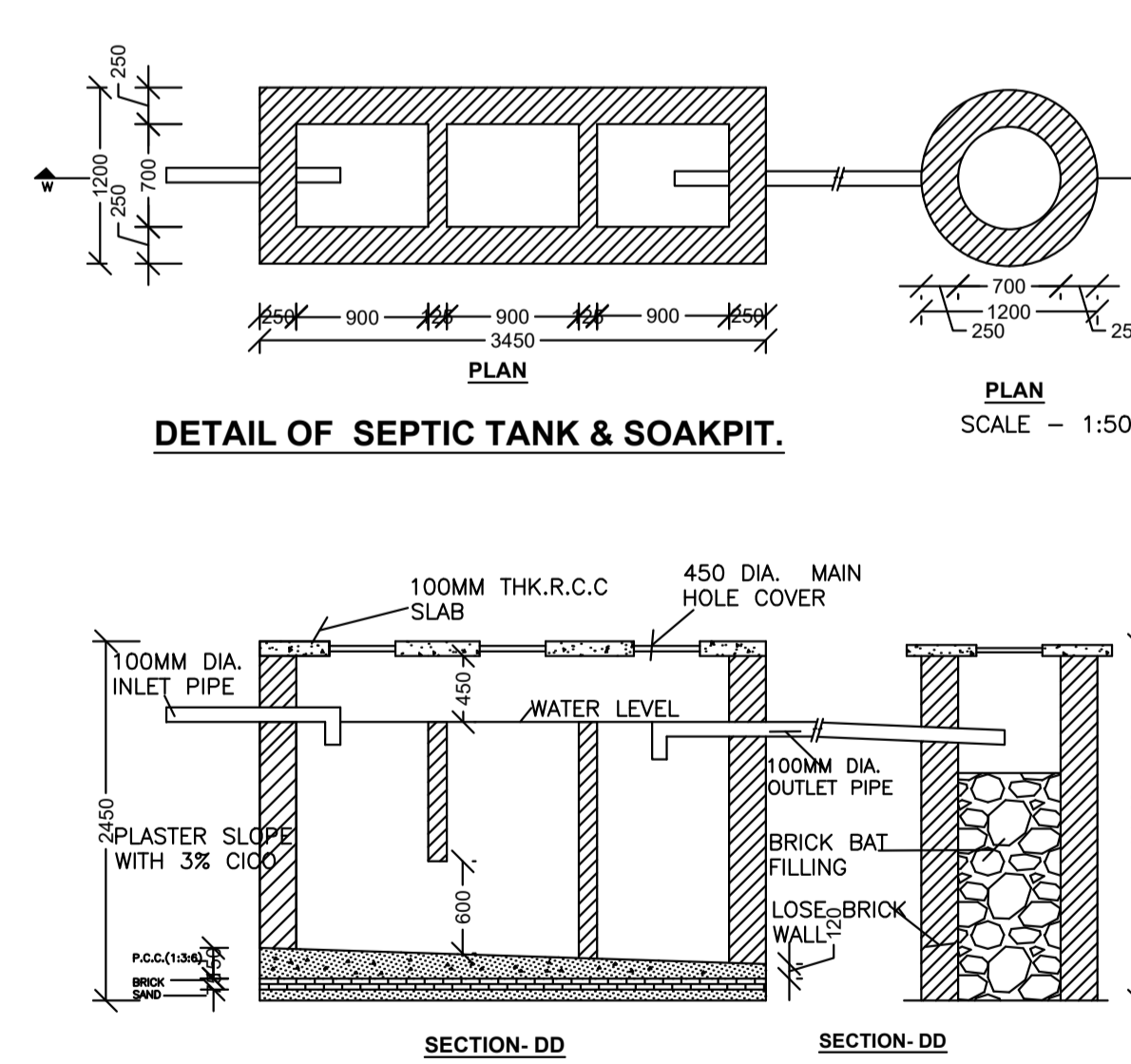
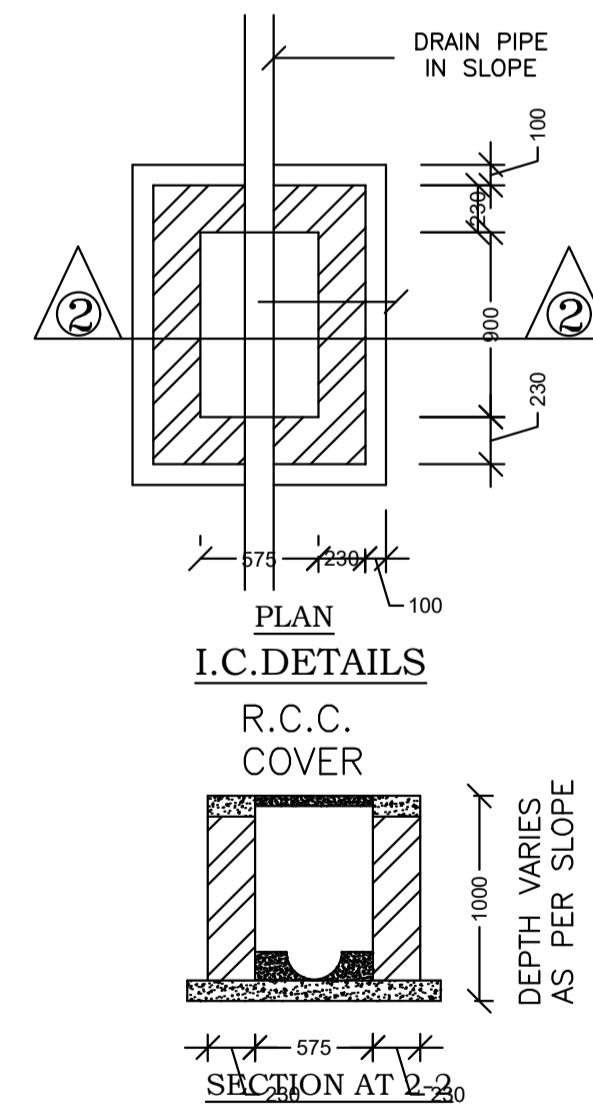

DETAIL OF SEPTIC TANK & SOAKPIT. SCALE - 1:50

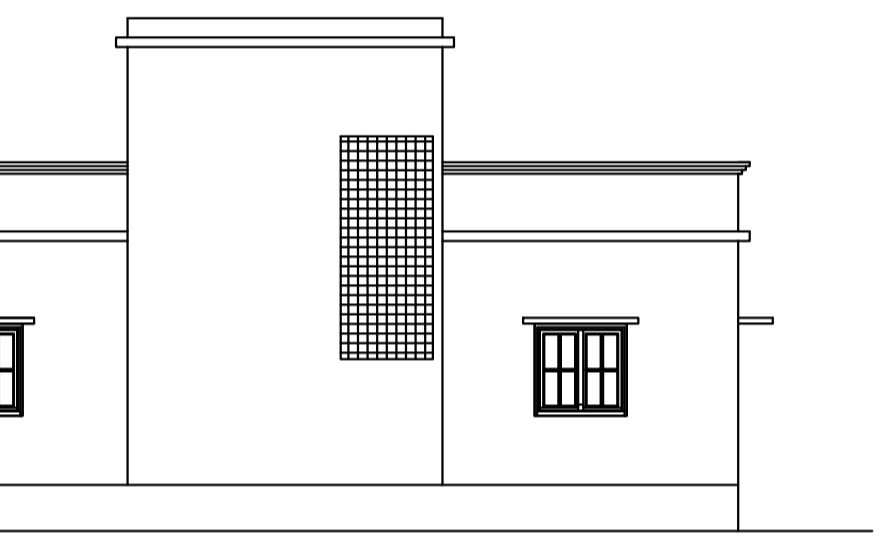

RIGHT SIDE ELEVATION SCALE 1:100

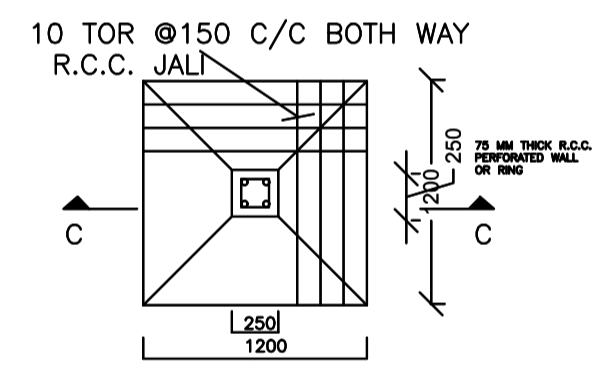

DETAIL OF FOUNDATION SCALE:- 1:50

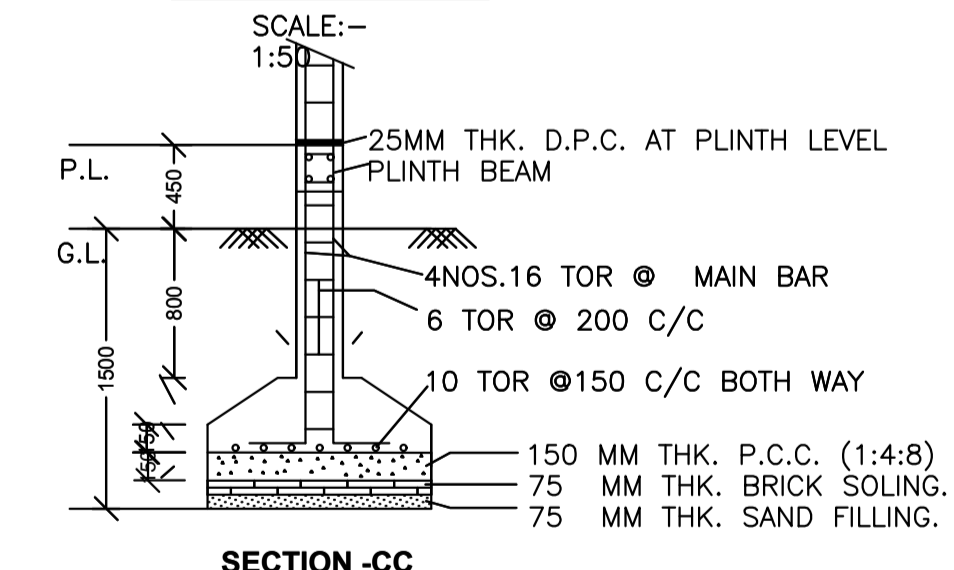

SECTION-CC

SCHEDULE OF DOOR:

BUILDING NAME	NAME	LENGTH	HEIGHT	NOS
A1 (RESIDENCE)	D2	0.76	2.10	02
A1 (RESIDENCE)	D1	0.91	2.10	01
A1 (RESIDENCE)	D	1.07	2.10	08

SCHEDULE OF WINDOW/VENTILATION:

BUILDING NAME	NAME	LENGTH	HEIGHT	NOS
A1 (RESIDENCE)	V	0.61	1.20	02
A1 (RESIDENCE)	W1	0.91	1.20	02
A1 (RESIDENCE)	W	1.22	1.20	06
A1 (RESIDENCE)	W2	1.52	1.20	01

UnitBUA Table for Building :A1 (RESIDENCE)

FLOOR	Name	UnitBUA Type	UnitBUA Area	Carpet Area	No. of Rooms	No. of Tenement
GROUND FLOOR PLAN	SPLIT1	FLAT	113.88	112.69	10	1
Total:	-	-	113.88	112.69	10	1

Building :A1 (RESIDENCE)

Floor Name	Total Built Up Area (Sq.mt.)	Proposed FAR Area (Sq.mt.)	Total FAR Area (Sq.mt.)	Total Consumed Additional FAR Area (Sq.mt.)	Tnmt (No.)
Ground Floor	145.29	145.29	145.29	145.29	01
Terrace Floor	0.00	0.00	0.00	0.00	00
Total:	145.29	145.29	145.29	145.29	01
Total Number of Same Buildings	1				
Total:	145.29	145.29	145.29	145.29	01

LTP NAME AND SIGNATURE	STRUCTURAL ENG'S NAME AND SIGNATURE	BUILDER NAME AND SIGNATURE	DIGITAL SIGNATURE
RAJESH KUMAR SINPC/DFTMN/0006/2017			

Proposal Basic Information	
Proposal File No.	SINPC/BP/0170/W02/2020
Owner Name	SHOBHA DEVI
Khata No	101
Plot No	4882
Village Name	Gotra
Use	Residential
SubUse	Bungalow/ Dwelling / Non Apartment

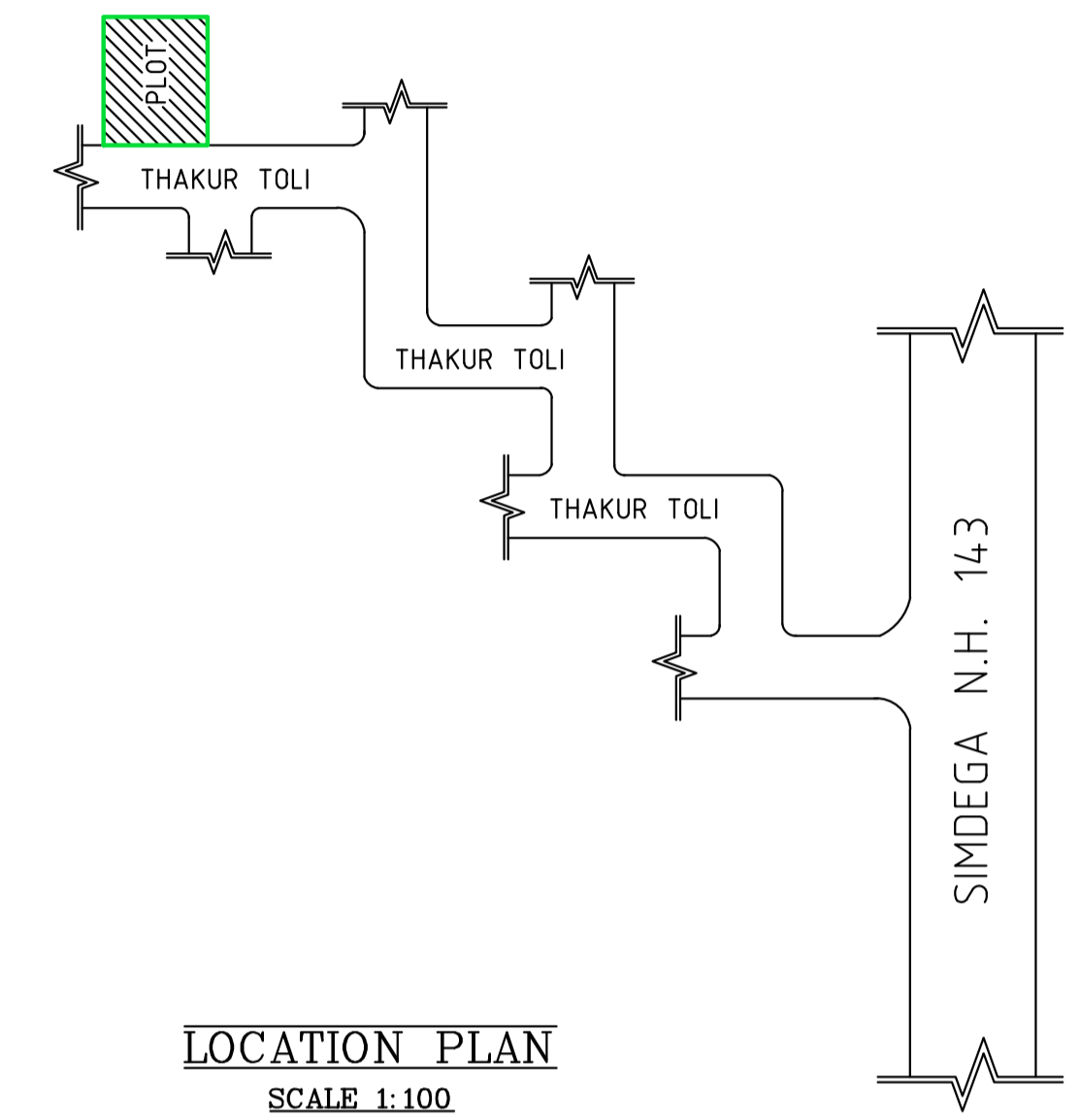

LTP NAME AND SIGNATURE	STRUCTURAL ENG'S NAME AND SIGNATURE	BUILDER NAME AND SIGNATURE	DIGITAL SIGNATURE
RAJESH KUMAR SINPC/DFTMN/0006/2017			