

SITE PLAN

FAR & Tenement Details (Table 4c-1)

Building	No. of Same Bldg	Total Built Up Area (Sq.mt.)	Proposed FAR Area (Sq.mt.) Resi.	Total FAR Area (Sq.mt.)	Total Consumed Additional FAR Area (Sq.mt.)	Tnmt (No.)
A1 (RESIDENCE)	1	295.26	295.26	295.26	295.26	01
Grand Total	1	295.26	295.26	295.26	295.26	01

Proposal Basic Information

Proposal File No.	SINPC/BP/0166/W07/2020
Owner Name	BIRENDRA SORENG
Khata No	95
Plot No	564
Village Name	Khijiri
Use	Residential
SubUse	Bungalow/ Dwelling / Non Apartment

AREA STATEMENT SIMDEGA NAGAR PANCHAYAT	VERSION NO: 1.0.44	SQ.MT.
PROJECT DETAIL:	VERSION DATE: 29/04/2019	
Region: JHARKHAND URBAN LOCAL BODIES	Plot Use: Residential	
District: SIMDEGA	Plot SubUse: Bungalow/ Dwelling / Non Apartment	
Authority: SIMDEGA NAGAR PANCHAYAT	PlotNearbyReligiousStructure: NA	
Inward No: SINPC/BP/0166/W07/2020	PlotSubPlot No: 564	
Application Type: General Proposal	North: -	
Project Type: Building Permission	South: -	
Nature of Development: New	East: -	
Location of Development Area: Old Area	West: -	
AREA DETAILS:		
AREA OF PLOT (Minimum)	(A)	597.39
Deduction for NetPlot Area		
Surrender Free of Cost		27.78
Total		27.78
NET AREA OF PLOT(Gross Plot Area - Deduction from Gross Plot area)	(A-Deductions)	569.61
Deduction for Balance Plot Area(from Gross Plot Area)		
Surrender Free of Cost		27.78
Common Plot		63.75
Total		91.53
BALANCE AREA OF PLOT(Net Plot Area - Recreational/Amenity space)	(A-Deductions)	505.86
PLOT AREA FOR COVERAGE(Net Plot Area)	(A-Deductions)	569.61
Plot Area for FAR (Net Plot Area + RoadWidening Area)	(A-Deductions)	597.39
COVERAGE CHECK		
Permissible Coverage area (60.00 %)		341.77
Proposed Coverage Area (25.92 %)		147.63
Total Prop. Coverage Area (25.92 %)		147.63
Balance coverage area (34.08 %)		194.14
FAR CHECK		
Perm. FAR Area (1.50)		896.09
Total Perm. FAR area		896.09
Residential FAR		295.26
Proposed FAR Area		295.26
Total Proposed FAR Area		295.26
Consumed FAR (Factor)		0.49
Balance FAR Area		600.83
BUILT UP AREA CHECK		
Total Proposed BuiltUp Area		295.26
ARCHITECT (Regd)	RAJESH KUMAR	
ENGINEER (Regd)		
SUPERVISOR (Regd)		
OWNER (Regd)	BIRENDRA SORENG	
DEVELOPMENT AUTHORITY	LOCAL BODY	

COLOR INDEX	
PLOT BOUNDARY	Black
ABUTTING ROAD	Green
PROPOSED CONSTRUCTION	Red
COMMON PLOT	Yellow
ROAD WIDENING AREA	Orange
EXISTING (To be retained)	Blue
EXISTING (To be demolished)	Light Blue

Buildingwise Floor FAR Details

Floor Name	Building Name		Total	
	Proposed Built Up Area (Sq.mt.)	Proposed FAR Area (Sq.mt.)	Total Proposed Built Up Area (Sq.mt.)	Total FAR Area (Sq.mt.)
Ground Floor	147.63	147.63	147.63	147.63
First Floor	147.63	147.63	147.63	147.63
Terrace Floor	0.00	0.00	0.00	0.00
Total	295.26	295.26	295.26	295.26

Building USE/SUBUSE Details

Building Name	Building Use	Building SubUse	Building Structure
A1 (RESIDENCE)	Residential	Bungalow/ Dwelling / Non Apartment	Non-Highrise

LTP NAME AND SIGNATURE	STRUCTURAL ENG'S NAME AND SIGNATURE	BUILDER NAME AND SIGNATURE	DIGITAL SIGNATURE
RAJESH KUMAR SINPC/DFTMN/0006/2017			

Proposal Basic Information	
Proposal File No.	SINPC/BP/0166/W07/220
Owner Name	BIRENDRA SORENG
Khata No	95
Plot No	564
Village Name	Khijri
Use	Residential
SubUse	Bungalow/ Dwelling / Non Apartment

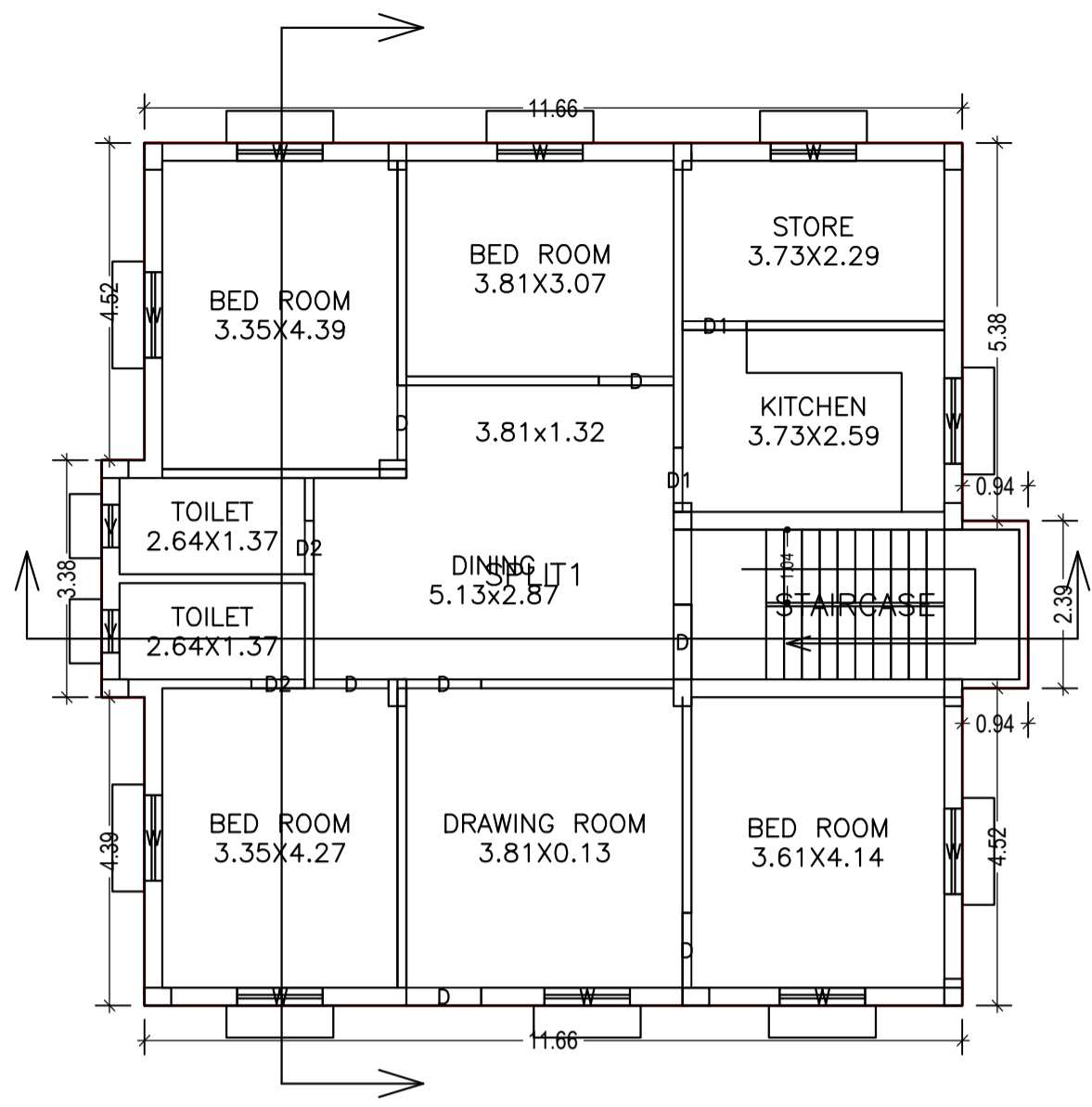

GROUND FLOOR PLAN (Proposed) (SCALE 1:100)

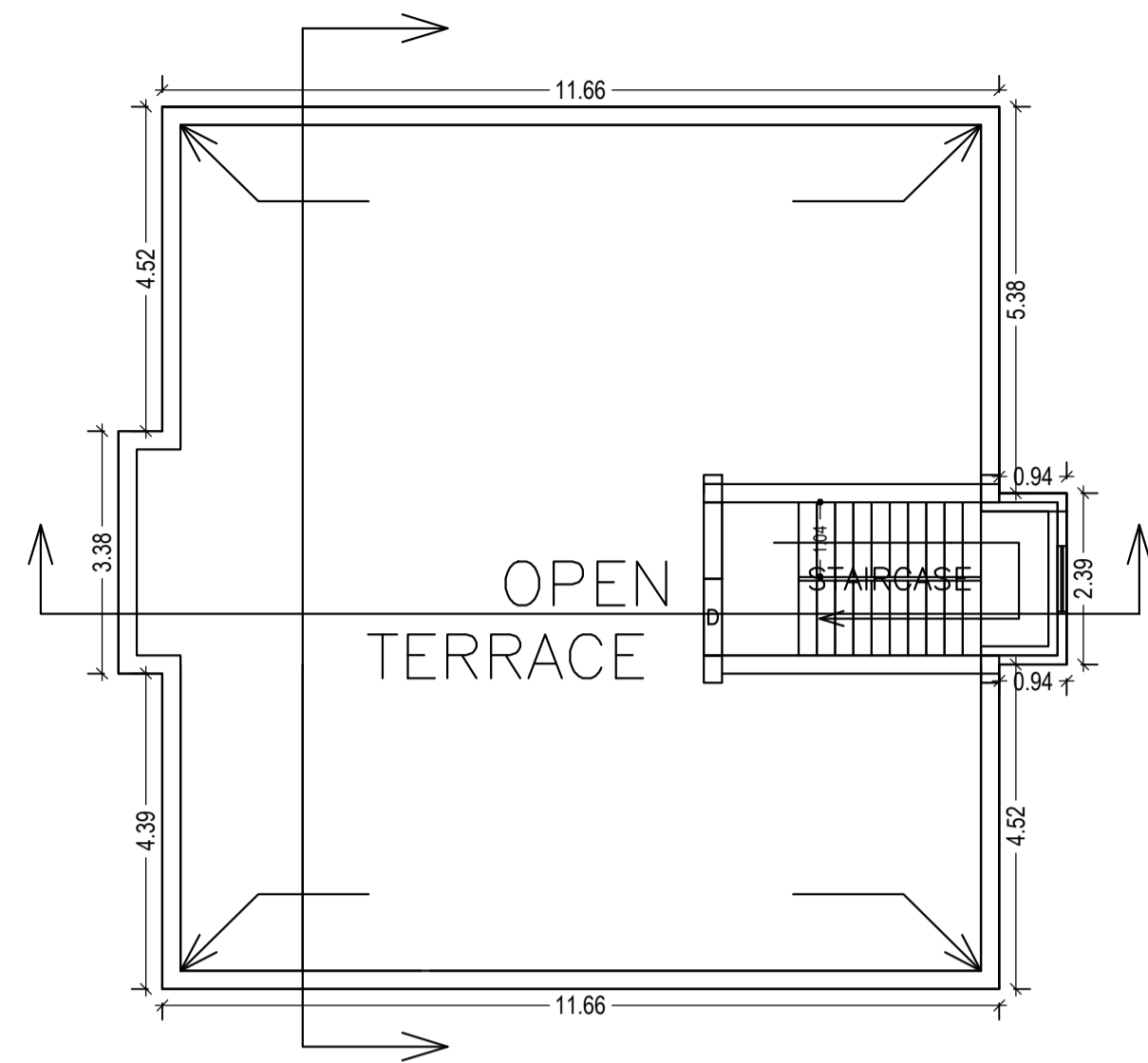

TERRACE FLOOR PLAN (SCALE 1:100)

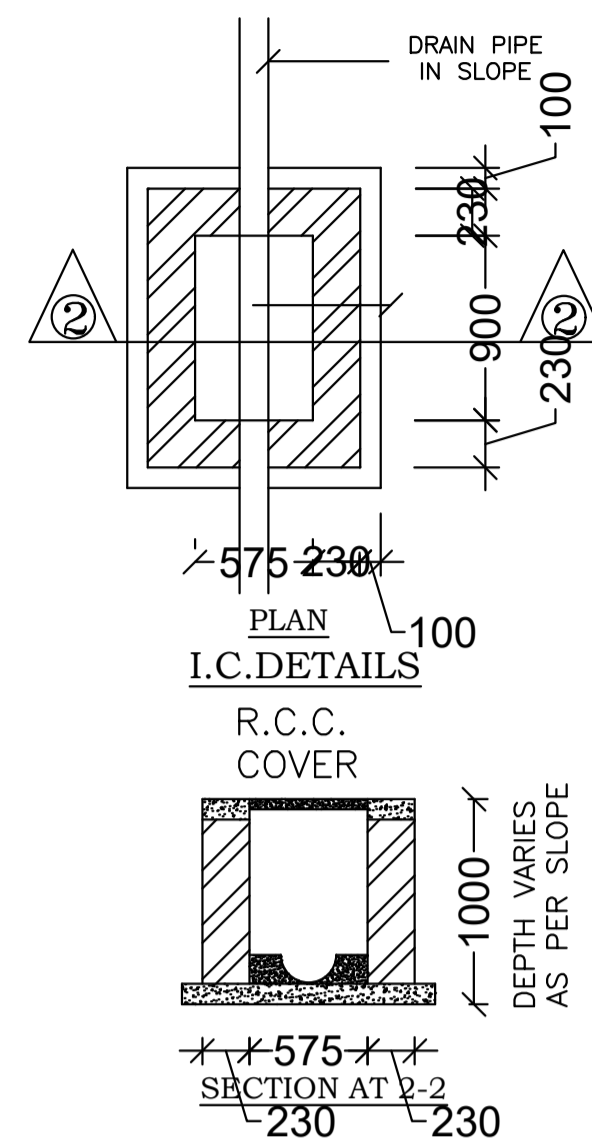

I.C. DETAILS R.C.C. COVER SECTION AT 2-2

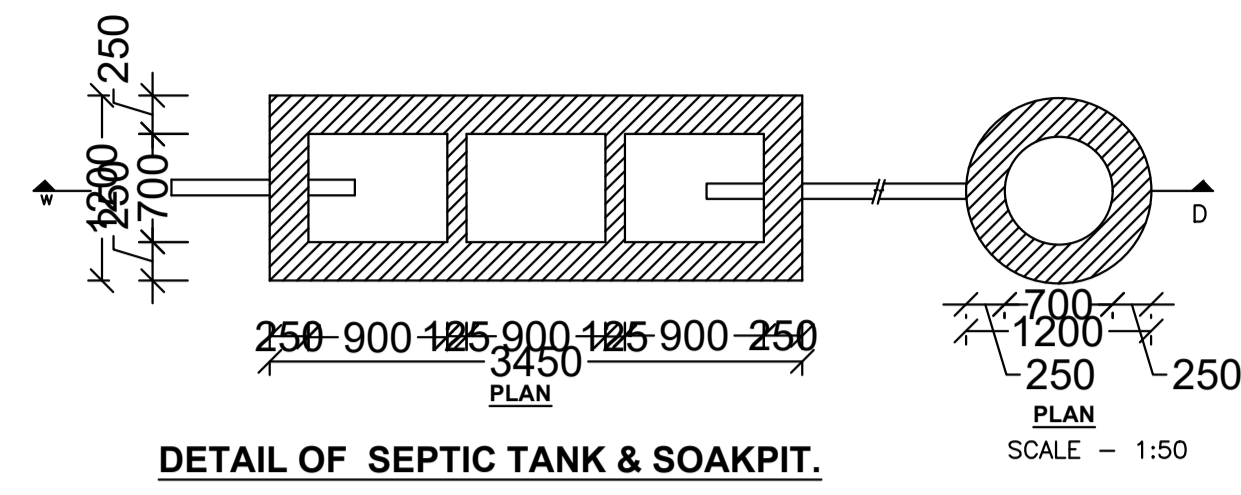

DETAIL OF SEPTIC TANK & SOAKPIT.

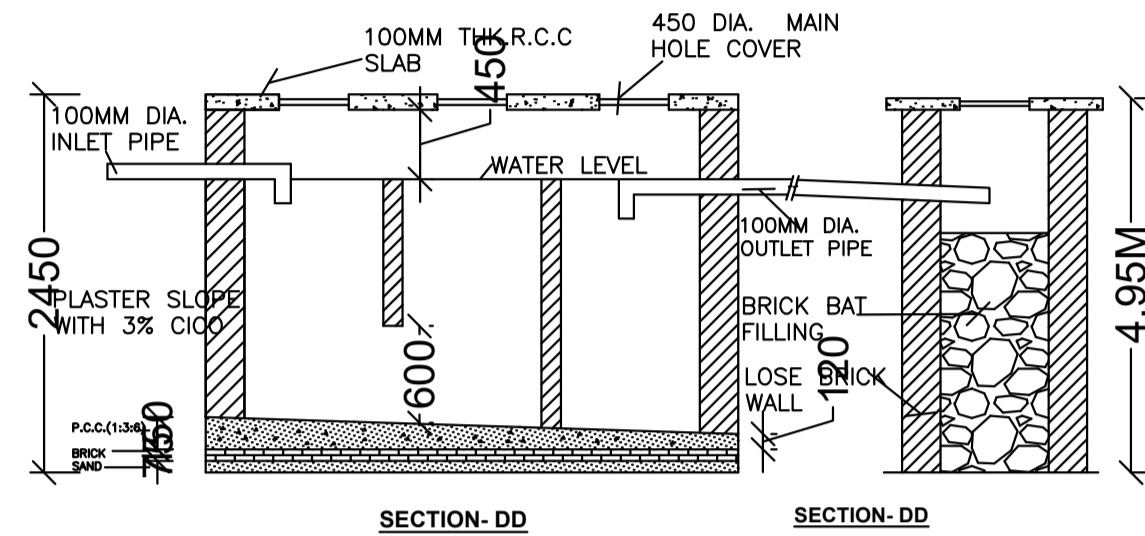

SECTION-DD

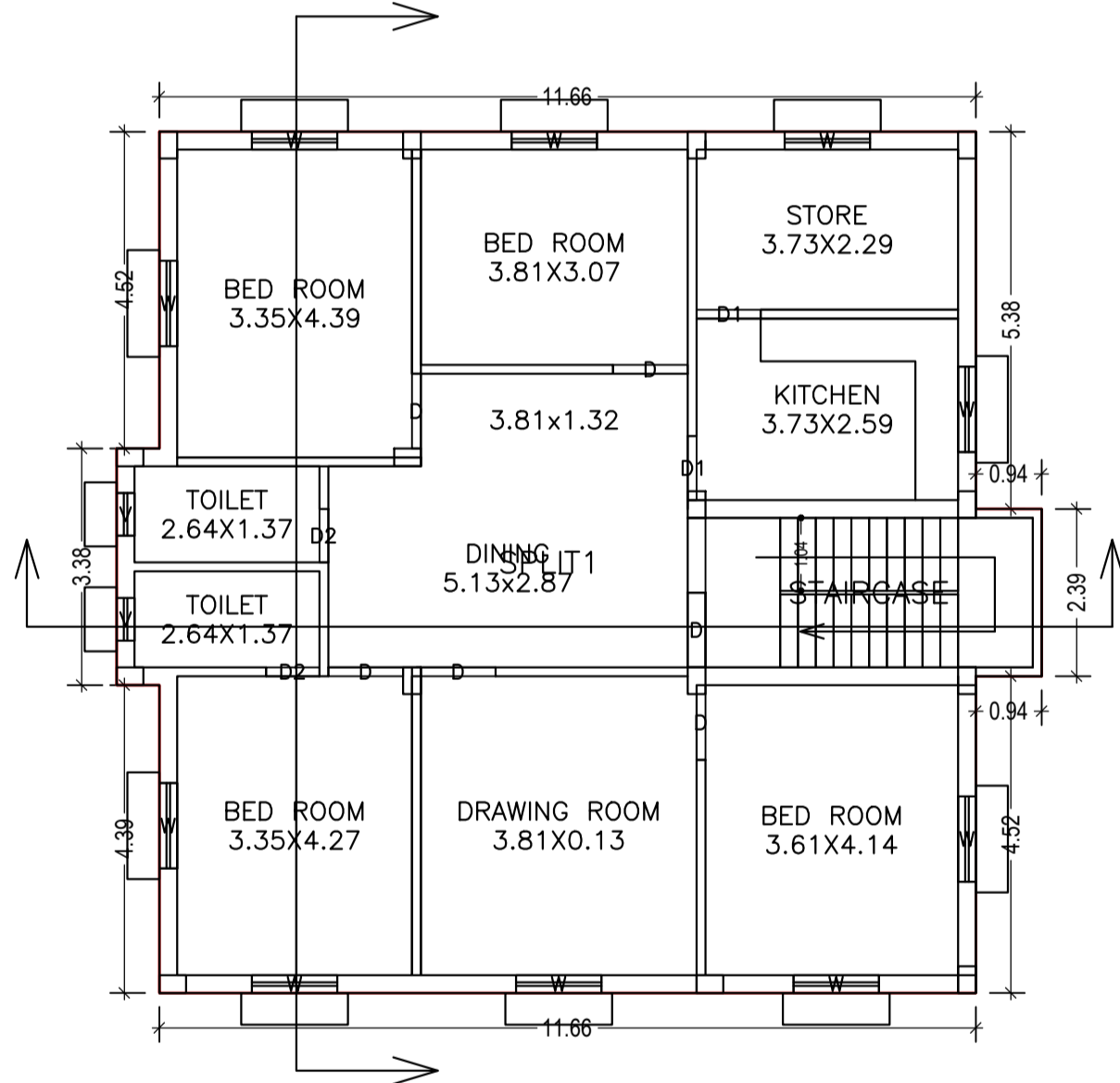

FIRST FLOOR PLAN (Proposed) (SCALE 1:100)

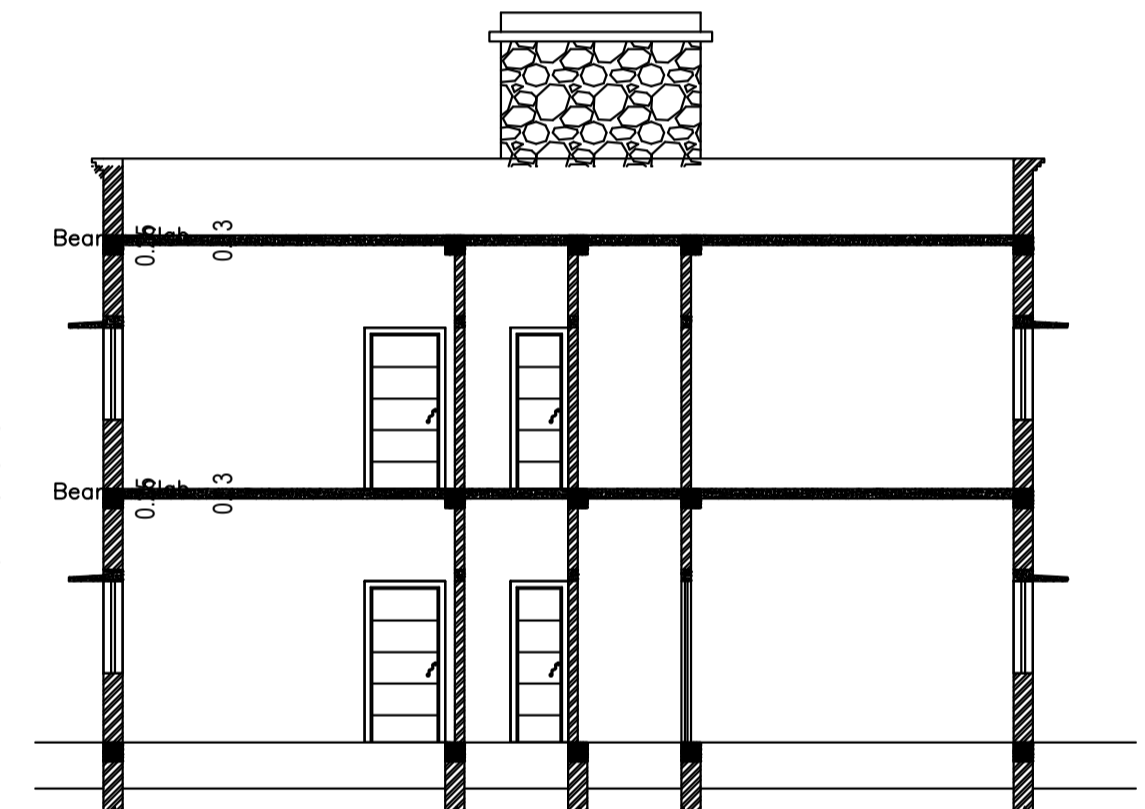

SECTION AT: X-X SCALE 1:100

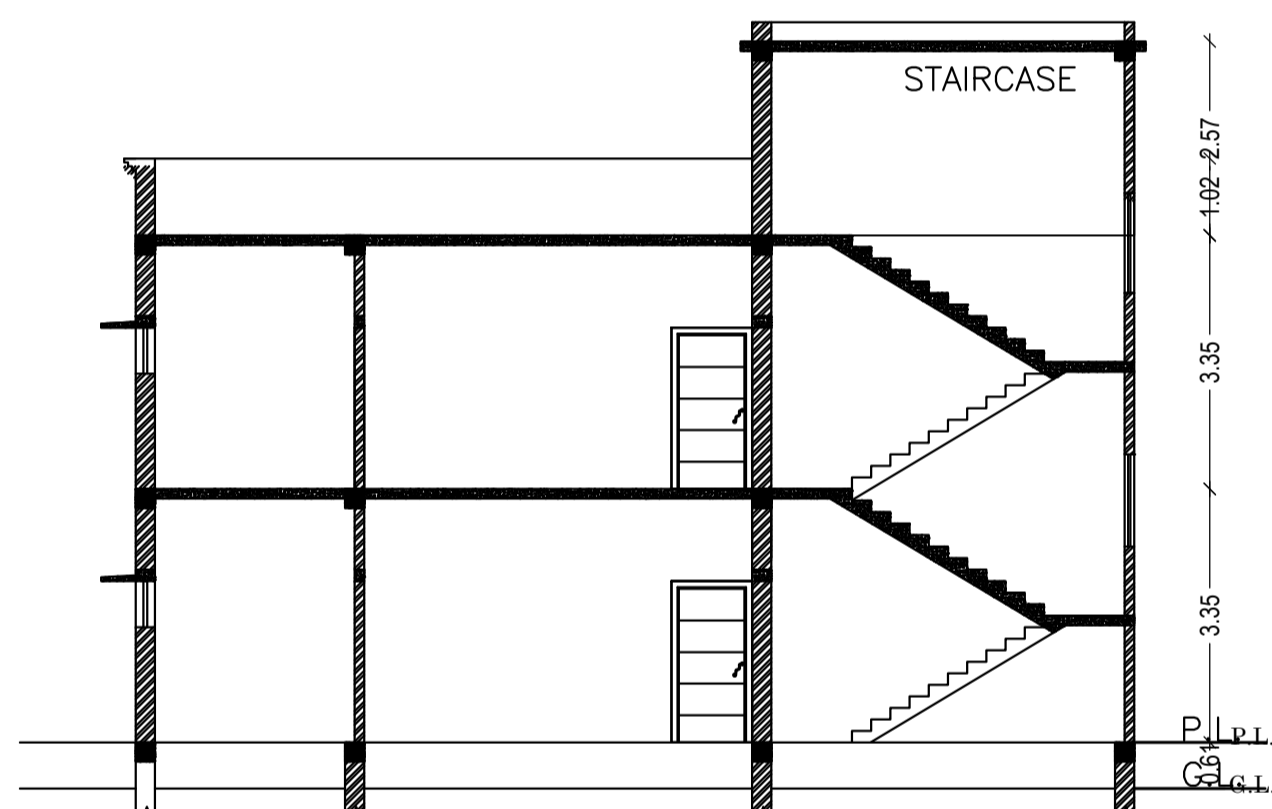

SECTION AT: Y-Y SCALE 1:100

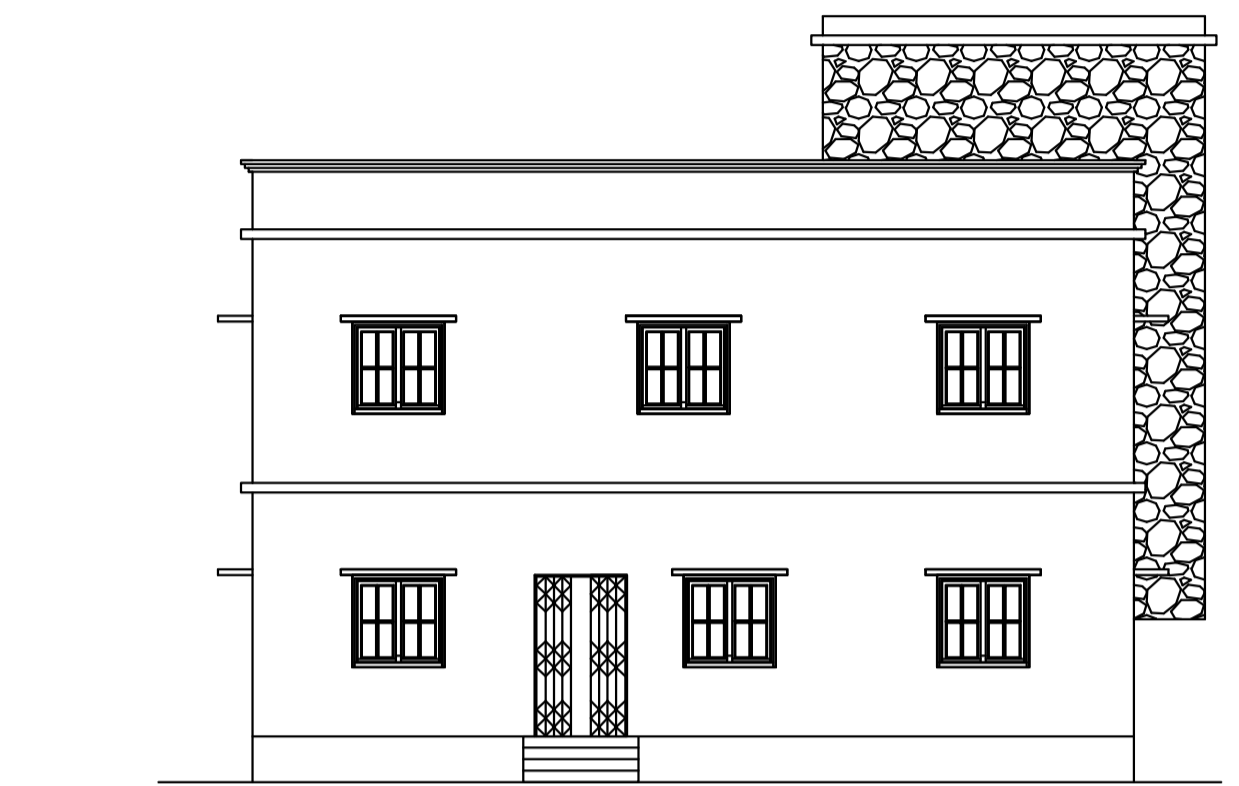

FRONT ELEVATION SCALE 1:100

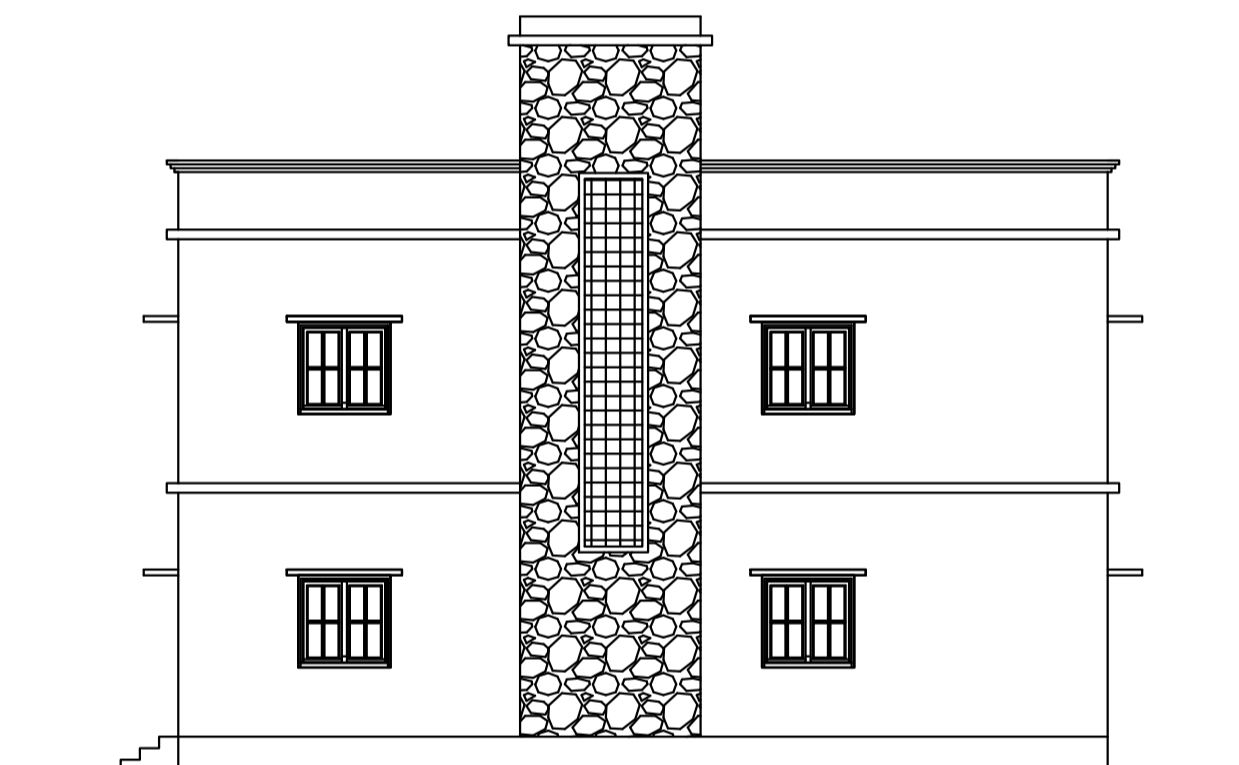

RIGHT SIDE ELEVATION SCALE 1:100

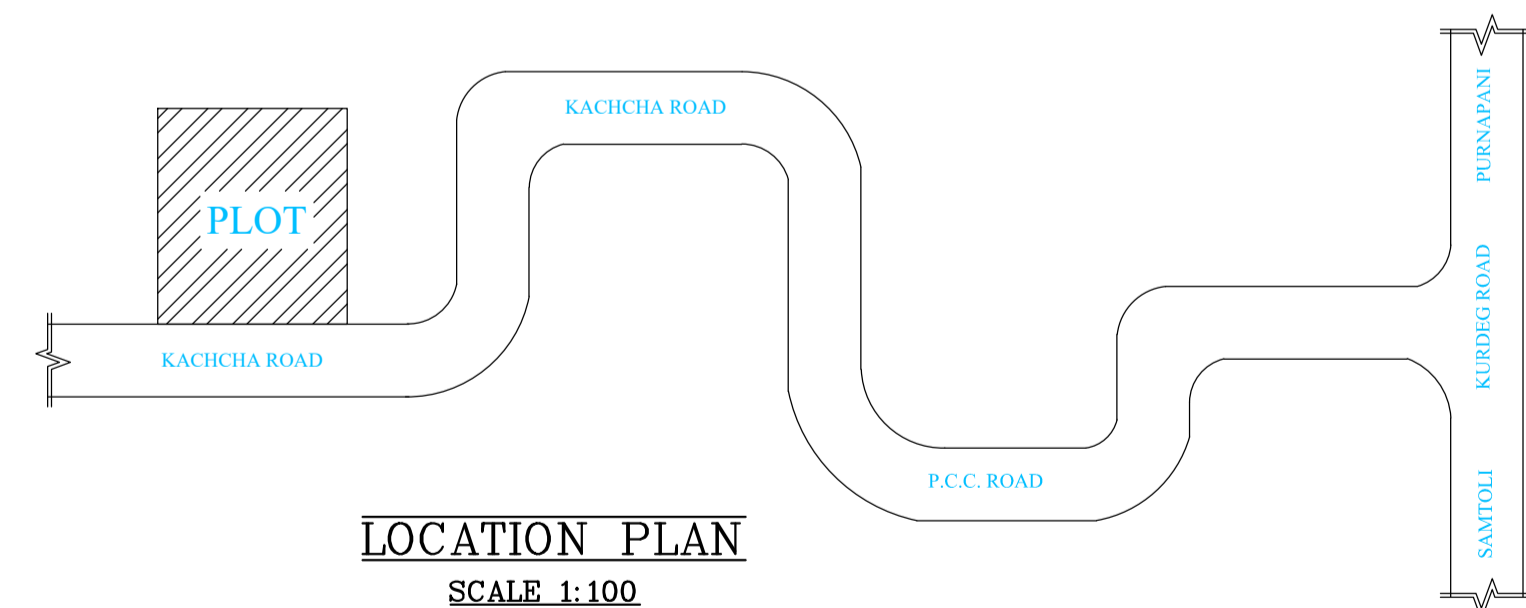

LOCATION PLAN SCALE 1:100

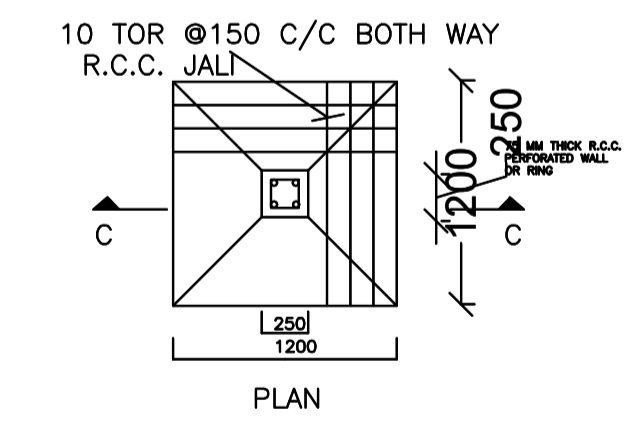

DETAIL OF FOUNDATION

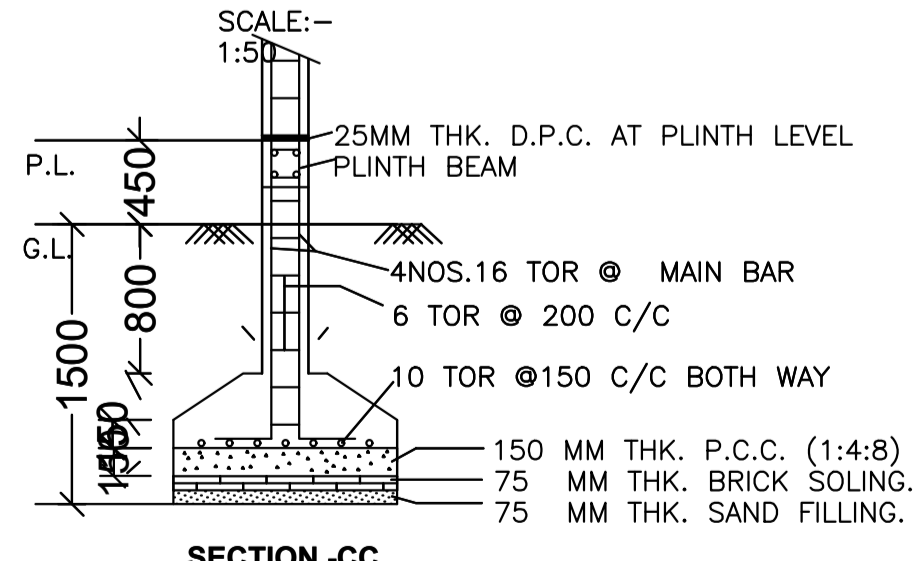

SECTION-CC

Building :A1 (RESIDENCE)

Floor Name	Total Built Up Area (Sq.mt.)	Proposed FAR Area (Sq.mt.)	Total FAR Area (Sq.mt.)	Total Consumed Additional FAR Area (Sq.mt.)	Tnmt (No.)
Ground Floor	147.63	147.63	147.63	147.63	01
First Floor	147.63	147.63	147.63	147.63	00
Terrace Floor	0.00	0.00	0.00	0.00	00
Total:	295.26	295.26	295.26	295.26	01
Total Number of Same Buildings	1				
Total:	295.26	295.26	295.26	295.26	01

SCHEDULE OF DOOR:

BUILDING NAME	NAME	LENGTH	HEIGHT	NOS
A1 (RESIDENCE)	D2	0.76	2.10	04
A1 (RESIDENCE)	D1	0.91	2.10	04
A1 (RESIDENCE)	D	1.07	2.10	13

SCHEDULE OF WINDOW/VENTILATION:

BUILDING NAME	NAME	LENGTH	HEIGHT	NOS
A1 (RESIDENCE)	V	0.61	1.20	04
A1 (RESIDENCE)	W	1.22	1.20	20

UnitBUA Table for Building :A1 (RESIDENCE)

FLOOR	Name	UnitBUA Type	UnitBUA Area	Carpet Area	No. of Rooms	No. of Tenement
GROUND FLOOR PLAN	SPLIT1	FLAT	245.93	242.44	10	1
FIRST FLOOR PLAN	SPLIT1	FLAT	0.00	0.00	10	0
Total:	-	-	245.93	242.44	20	1

LTP NAME AND SIGNATURE	STRUCTURAL ENG'S NAME AND SIGNATURE	BUILDER NAME AND SIGNATURE	DIGITAL SIGNATURE
RAJESH KUMAR SINPC/DFTMN/0006/2017			

Proposal Basic Information

Proposal File No.	SINPC/BP/0166/W07/220
Owner Name	BIRENDRA SORENG
Khata No	95
Plot No	564
Village Name	Khijri
Use	Residential
SubUse	Bungalow/ Dwelling / Non Apartment

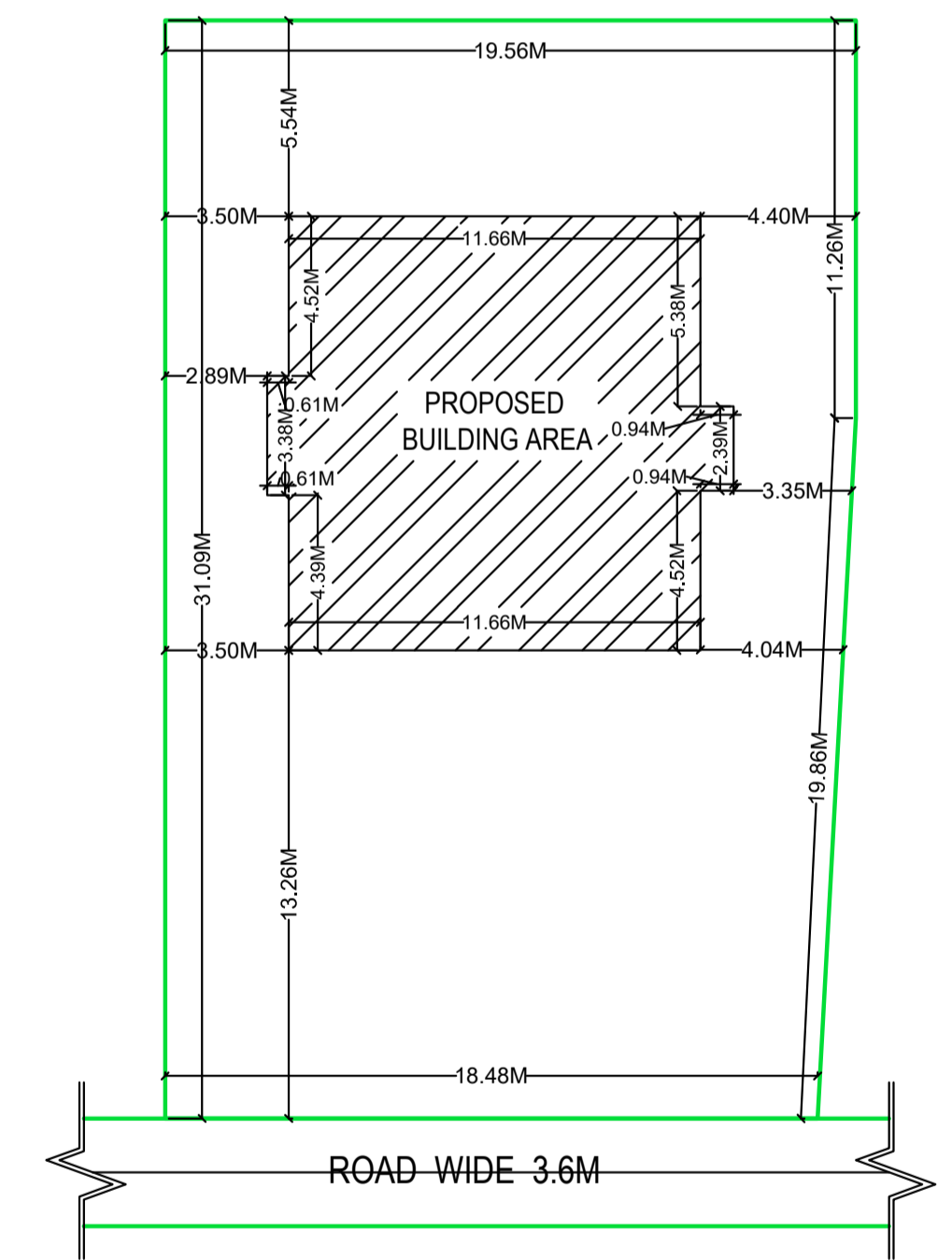
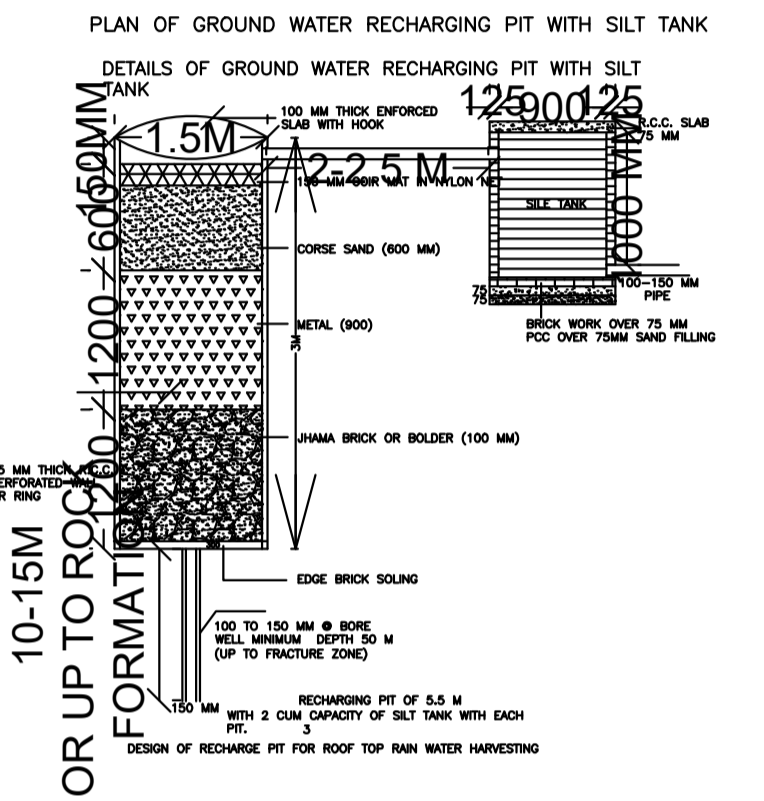
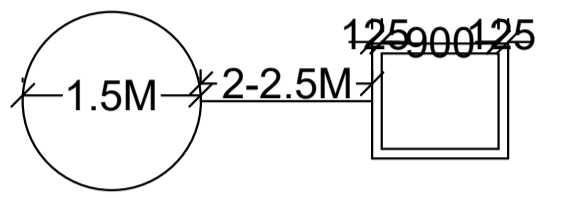

KEY PLAN
SCALE 1:200

LTP NAME AND SIGNATURE	STRUCTURAL ENG'S NAME AND SIGNATURE	BUILDER NAME AND SIGNATURE	DIGITAL SIGNATURE
RAJESH KUMAR SINPC/DFTMN/0006/2017			