

SITE PLAN

FAR & Tenement Details (Table 4c-1)

Building	No. of Same Bldg	Total Built Up Area (Sq.mt.)	Proposed FAR Area (Sq.mt.) Resi.	Total FAR Area (Sq.mt.)	Total Consumed Additional FAR Area (Sq.mt.)	Tnmt (No.)
A1 (RESIDENCE)	1	235.70	235.70	235.70	235.70	02
Grand Total	1	235.70	235.70	235.70	235.70	02

Proposal Basic Information

Proposal File No.	SINPC/BP/0164/W02/2020
Owner Name	SHAMBHUNATH PRADHAN
Khata No	12
Plot No	4835
Village Name	Gotra
Use	Residential
SubUse	Bungalow/ Dwelling / Non Apartment

Required Parking (Table 7a)

Building Name	Type	SubUse	Area (Sq.mt.)	Units		Car		Visitors Car			
				Reqd.	Prop.	Reqd./Unit	Reqd.	Prop.	Reqd./Unit	Reqd.	Prop.
A1 (RESIDENCE)	Residential	Bungalow/ Dwelling / Non Apartment	>0	1	2.00	1	2	-	-	-	-
			>0	1	2.00	-	-	-	1	1	-
Total			-	-	-	-	2	3	-	1	1

Parking Check (Table 7b)

Vehicle Type	Reqd.		Prop.	
	No.	Area	No.	Area
Car	-	-	3	51.47
Total Car	2	25.00	3	51.47
Visitor's Car Parking	-	-	1	13.84
Total Visitor Parking	1	12.50	1	13.84
Total		37.50		79.15

AREA STATEMENT SIMDEGA NAGAR PANCHAYAT	VERSION NO: 1.0.44	VERSION DATE: 29/04/2019
PROJECT DETAIL:	Region: JHARKHAND URBAN LOCAL BODIES	Plot Use: Residential
	District: SIMDEGA	Plot SubUse: Bungalow/ Dwelling / Non Apartment
	Authority: SIMDEGA NAGAR PANCHAYAT	PlotNearbyReligiousStructure: NA
	Inward No: SINPC/BP/0164/W02/2020	PlotSubPlot No: 4835
	Application Type: General Proposal	North: -
	Project Type: Building Permission	South: -
	Nature of Development: New	East: -
	Location of Development Area: Old Area	West: -
AREA DETAILS:	AREA OF PLOT (Minimum)	(A) 314.58
	Deduction for NetPlot Area	
	Surrender Free of Cost	17.49
	Total	17.49
	NET AREA OF PLOT(Gross Plot Area - Deduction from Gross Plot area)	(A-Deductions) 297.08
	Deduction for Balance Plot Area(from Gross Plot Area)	
	Surrender Free of Cost	17.49
	Common Plot	31.52
	Total	49.01
	BALANCE AREA OF PLOT(Net Plot Area - Recreational/Amenity space)	(A-Deductions) 265.56
	PLOT AREA FOR COVERAGE(Net Plot Area)	(A-Deductions) 297.08
	Plot Area for FAR (Net Plot Area + RoadWidening Area)	(A-Deductions) 314.58
COVERAGE CHECK	Permissible Coverage area (60.00 %)	178.25
	Proposed Coverage Area (39.67 %)	117.85
	Total Prop. Coverage Area (39.67 %)	117.85
	Balance coverage area (20.33 %)	60.40
FAR CHECK	Perm. FAR Area (1.50)	471.87
	Total Perm. FAR area	471.87
	Residential FAR	235.70
	Proposed FAR Area	235.70
	Total Proposed FAR Area	235.70
	Consumed FAR (Factor)	0.75
	Balance FAR Area	236.17
BUILT UP AREA CHECK	Total Proposed BuiltUp Area	235.70
ARCHITECT (Regd)		RAJESH KUMAR
ENGINEER (Regd)		
SUPERVISOR (Regd)		
OWNER (Regd)		SHAMBHUNATH PRADHAN
DEVELOPMENT AUTHORITY		LOCAL BODY

COLOR INDEX	
PLOT BOUNDARY	Black
ABUTTING ROAD	Green
PROPOSED CONSTRUCTION	Red
COMMON PLOT	Yellow
ROAD WIDENING AREA	Orange
EXISTING (To be retained)	Blue
EXISTING (To be demolished)	Light Blue

Buildingwise Floor FAR Details

Floor Name	Building Name A1 (RESIDENCE)		Total	
	Proposed Built Up Area (Sq.mt.)	Proposed FAR Area (Sq.mt.)	Total Proposed Built Up Area (Sq.mt.)	Total FAR Area (Sq.mt.)
Ground Floor	117.85	117.85	117.85	117.85
First Floor	117.85	117.85	117.85	117.85
Terrace Floor	0.00	0.00	0.00	0.00
Total	235.70	235.70	235.70	235.70

Building USE/SUBUSE Details

Building Name	Building Use	Building SubUse	Building Structure
A1 (RESIDENCE)	Residential	Bungalow/ Dwelling / Non Apartment	Non-Highrise

LTP NAME AND SIGNATURE	STRUCTURAL ENG'S NAME AND SIGNATURE	BUILDER NAME AND SIGNATURE	DIGITAL SIGNATURE
RAJESH KUMAR SINPC/DFTMN/0006/2017			

Proposal Basic Information	
Proposal File No.	SINPC/BP/0164/W02/2020
Owner Name	SHAMBHUNATH PRADHAN
Khata No	12
Plot No	4835
Village Name	Gotra
Use	Residential
SubUse	Bungalow/ Dwelling / Non Apartment

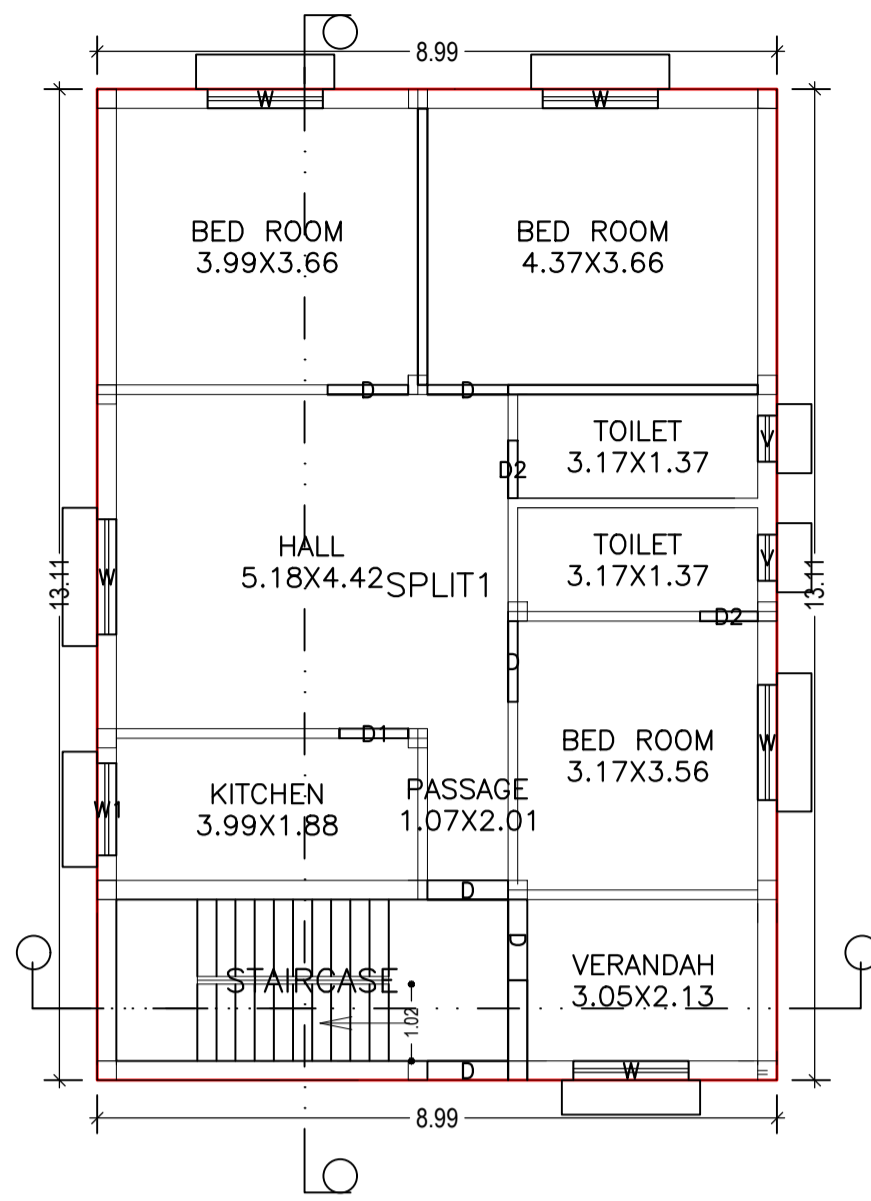

GROUND FLOOR PLAN (Proposed) (SCALE 1:100)

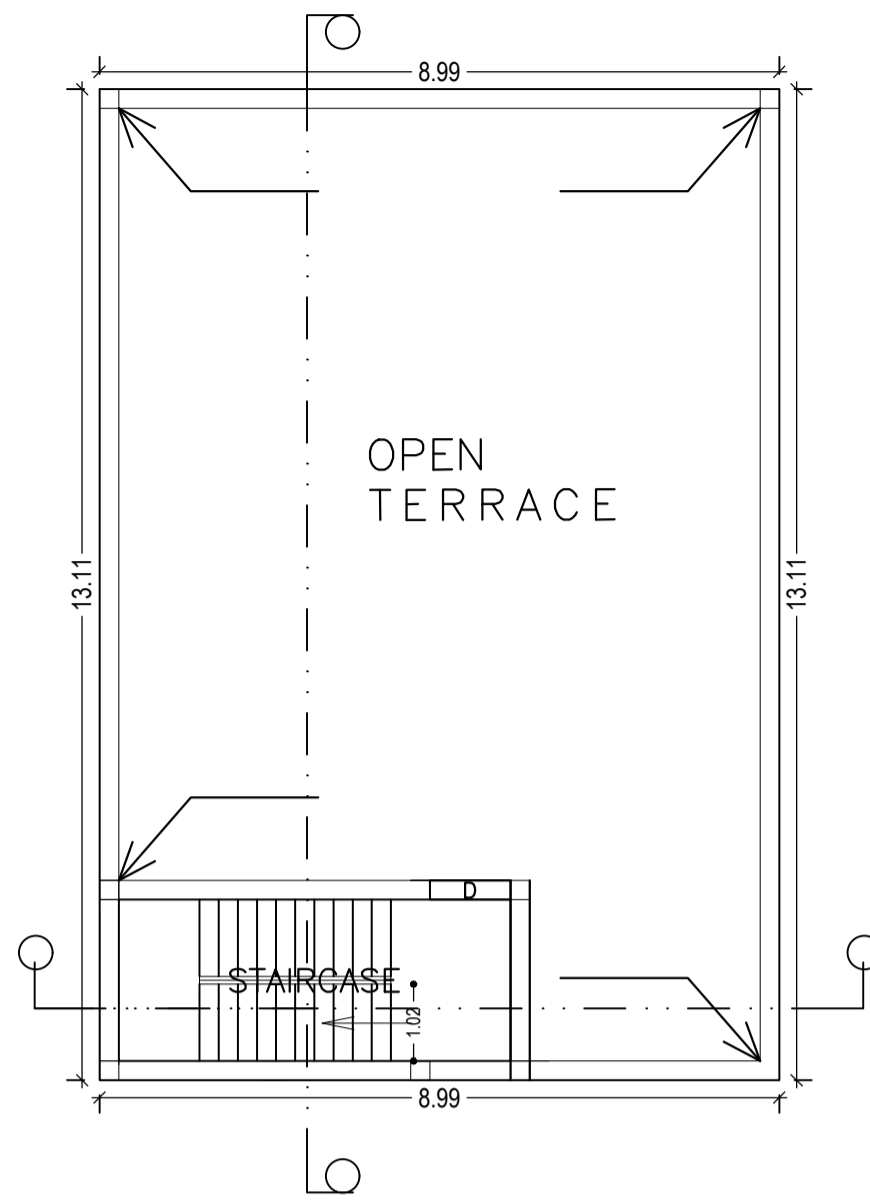

TERRACE FLOOR PLAN (SCALE 1:100)

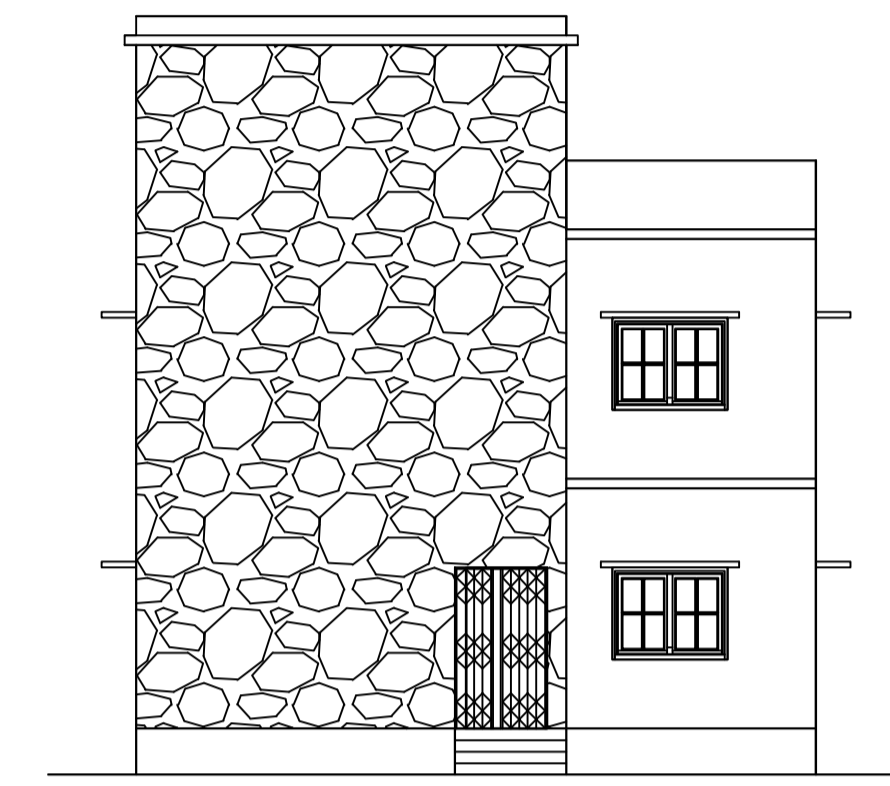
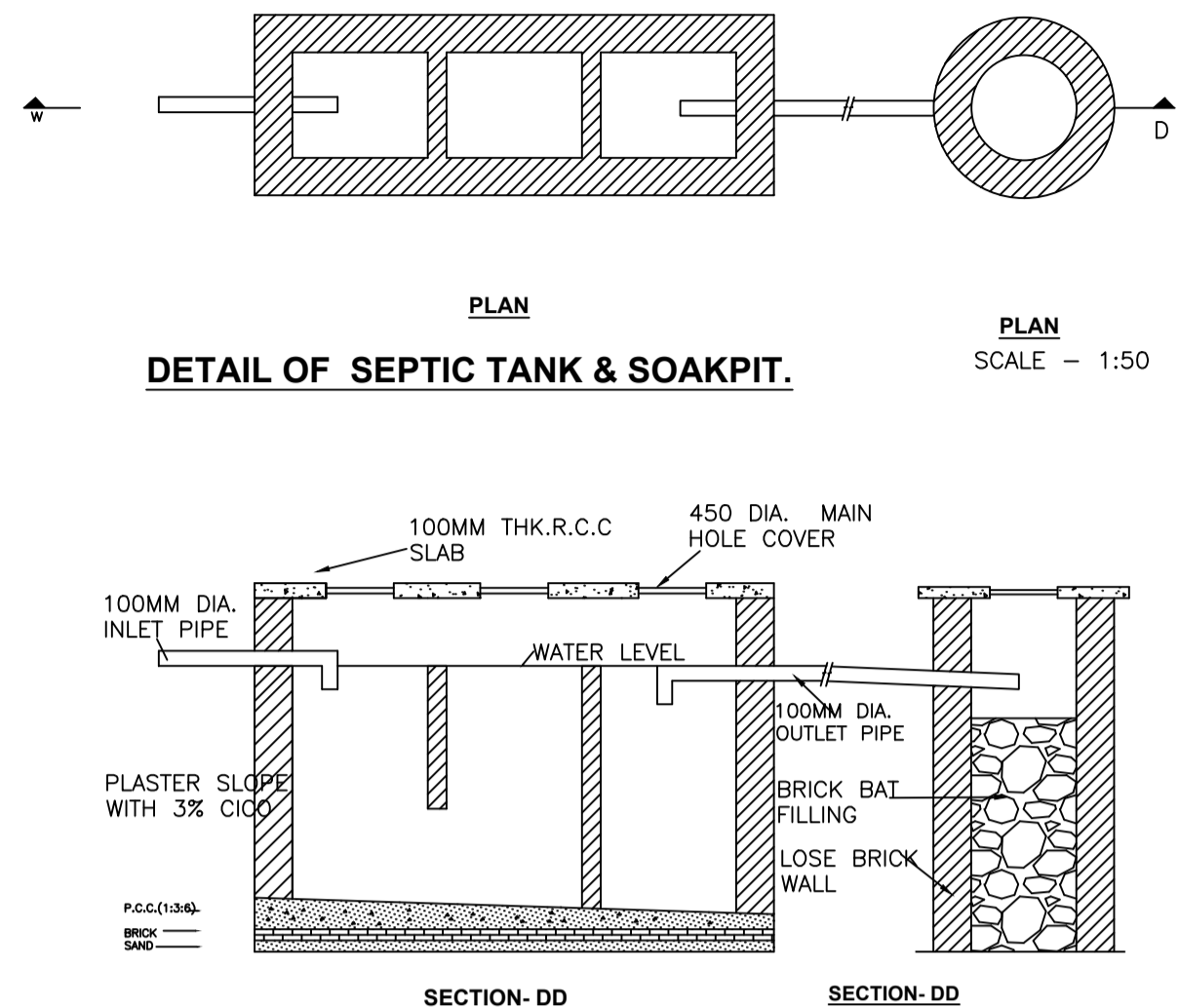
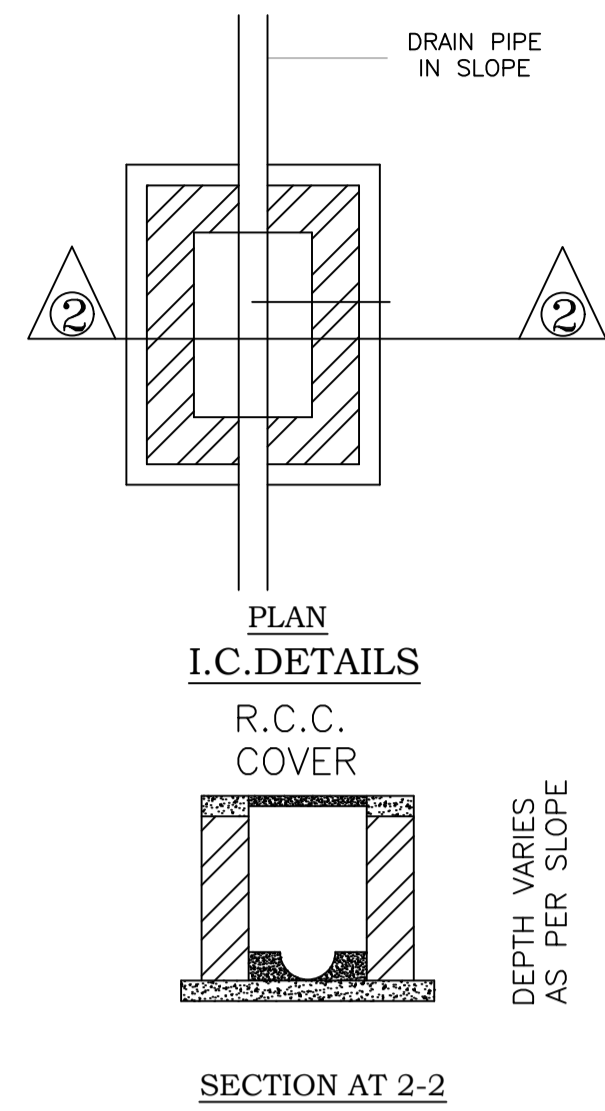

FRONT ELEVATION (SCALE 1:100)

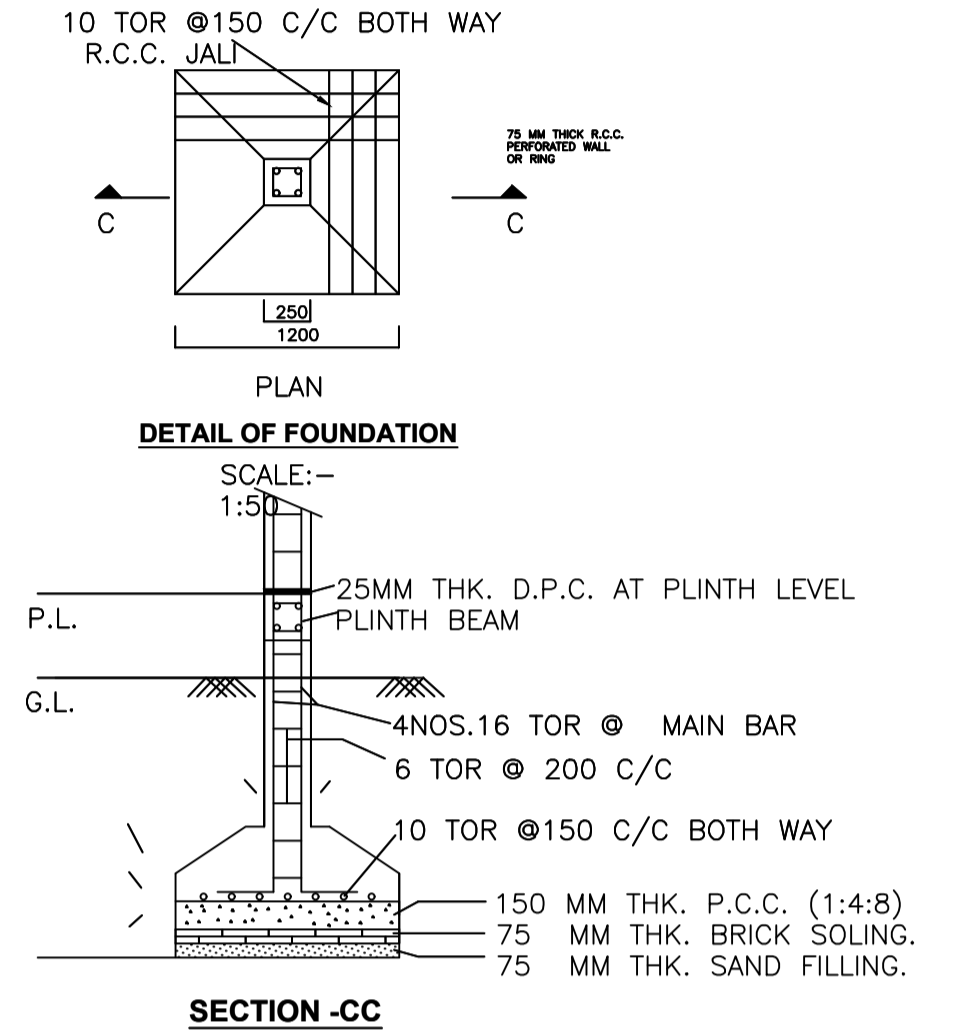

SECTION -CC

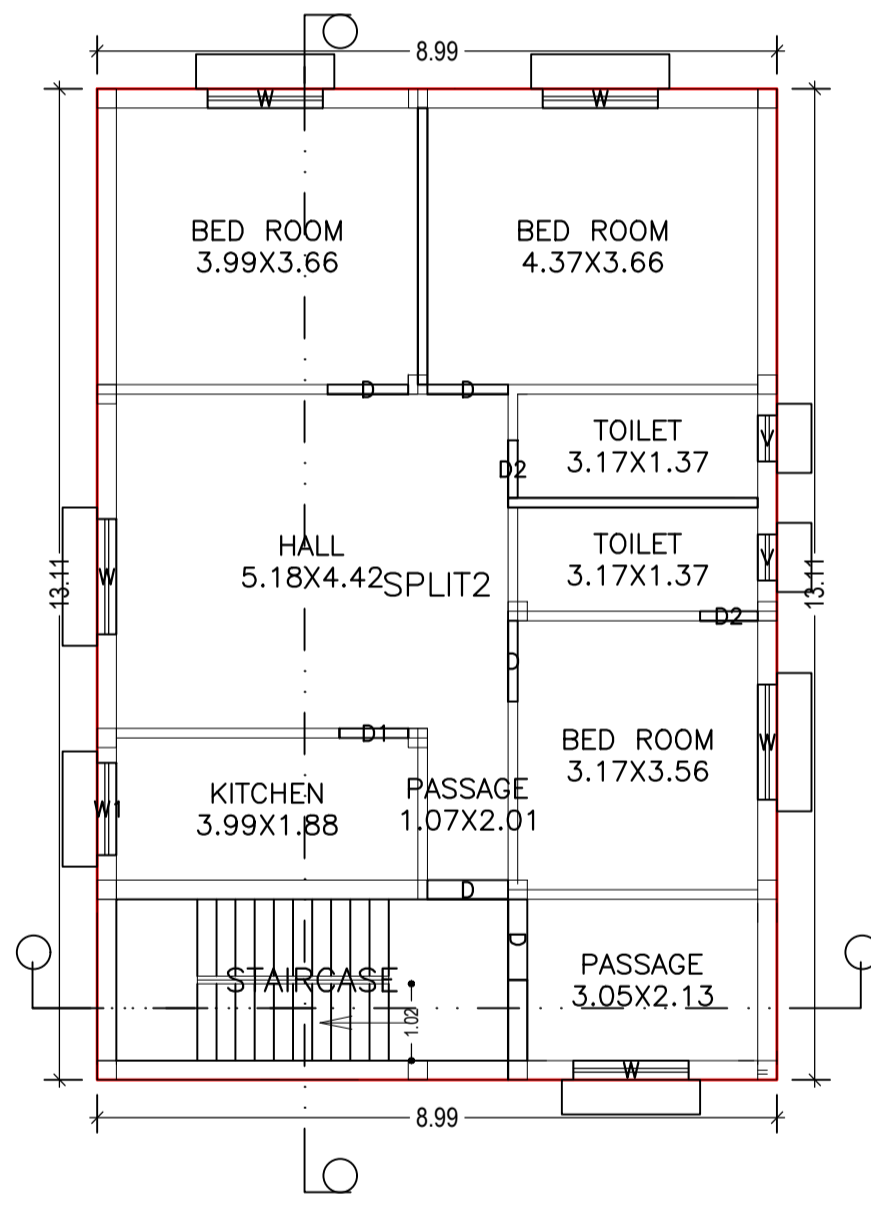

FIRST FLOOR PLAN (Proposed) (SCALE 1:100)

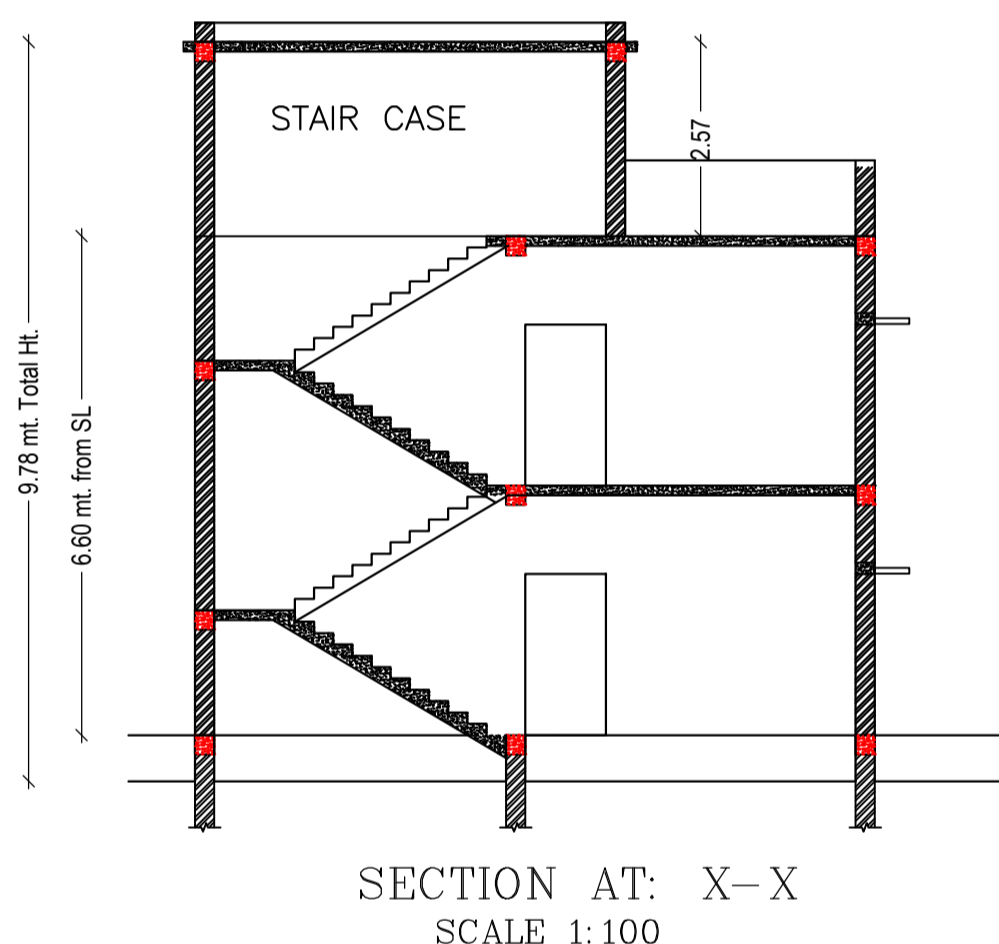

SECTION AT: X-X (SCALE 1:100)

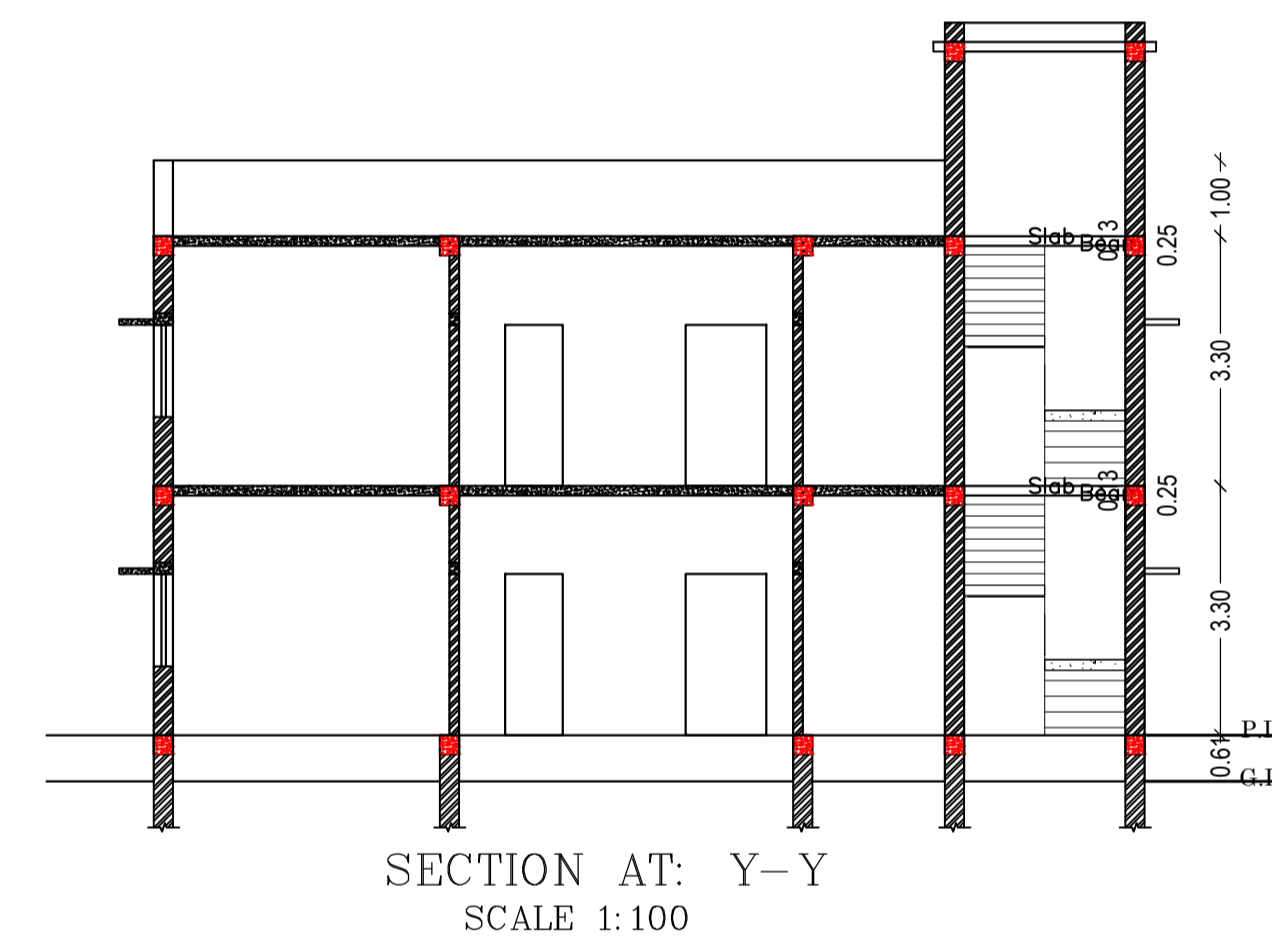

SECTION AT: Y-Y (SCALE 1:100)

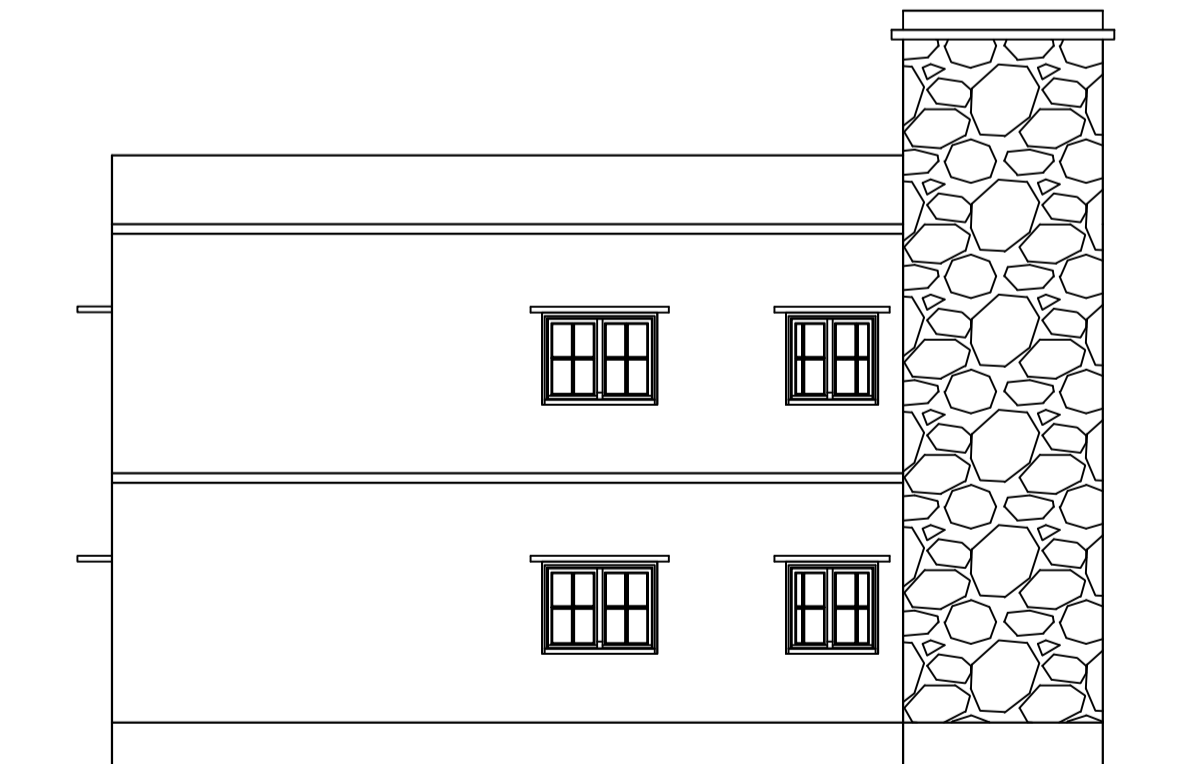

LEFT SIDE ELEVATION (SCALE 1:100)

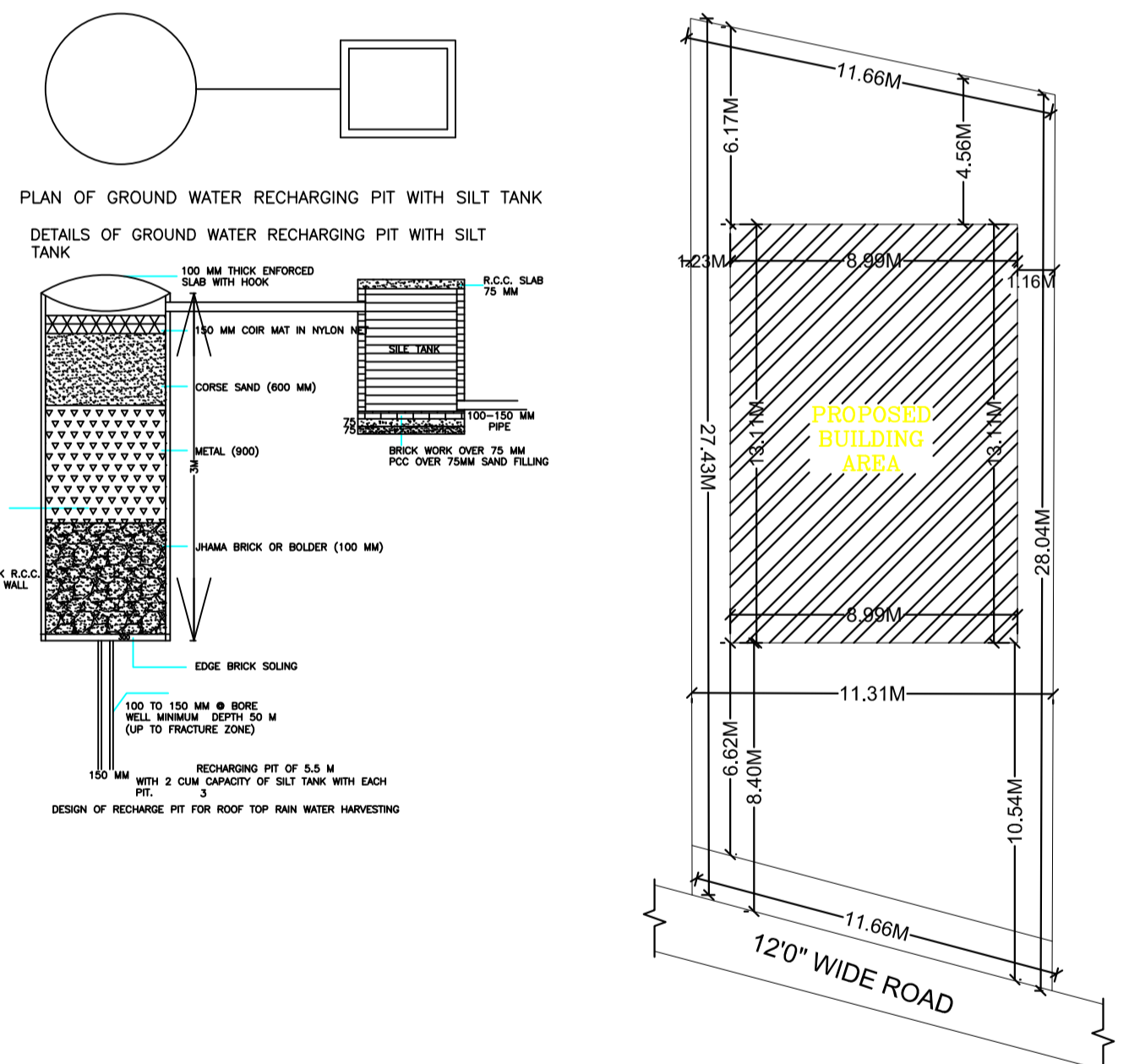

KEY PLAN (SCALE 1:200)

LOCATION PLAN (SCALE 1:100)

Building :A1 (RESIDENCE)

Floor Name	Total Built Up Area (Sq.mt.)	Proposed FAR Area (Sq.mt.) Resi.	Total FAR Area (Sq.mt.)	Total Consumed Additional FAR Area (Sq.mt.)	Tnmt (No.)
Ground Floor	117.85	117.85	117.85	117.85	01
First Floor	117.85	117.85	117.85	117.85	01
Terrace Floor	0.00	0.00	0.00	0.00	00
Total:	235.70	235.70	235.70	235.70	02
Total Number of Same Buildings	1				
Total:	235.70	235.70	235.70	235.70	02

SCHEDULE OF DOOR:

BUILDING NAME	NAME	LENGTH	HEIGHT	NOS
A1 (RESIDENCE)	D2	0.76	2.10	04
A1 (RESIDENCE)	D1	0.91	2.10	02
A1 (RESIDENCE)	D	1.07	2.10	10

SCHEDULE OF WINDOW/VENTILATION:

BUILDING NAME	NAME	LENGTH	HEIGHT	NOS
A1 (RESIDENCE)	V	0.61	1.20	04
A1 (RESIDENCE)	W1	1.22	1.20	02
A1 (RESIDENCE)	W	1.52	1.20	10

UnitBUA Table for Building :A1 (RESIDENCE)

FLOOR	Name	UnitBUA Type	UnitBUA Area	Carpet Area	No. of Rooms	No. of Tenement
GROUND FLOOR PLAN	SPLIT1	FLAT	93.92	93.03	9	1
FIRST FLOOR PLAN	SPLIT2	FLAT	93.92	93.03	9	1
Total:	-	-	187.84	186.06	18	2

LTP NAME AND SIGNATURE	STRUCTURAL ENG'S NAME AND SIGNATURE	BUILDER NAME AND SIGNATURE	DIGITAL SIGNATURE
RAJESH KUMAR SINPC/DFTMN/0006/2017			