

FAR & Tenement Details (Table 4c-1)

Building	No. of Same Bldg	Total Built Up Area (Sq.mt.)	Proposed FAR Area (Sq.mt.) Resi.	Total FAR Area (Sq.mt.)	Total Consumed Additional FAR Area (Sq.mt.)	Tnmt (No.)
A (SMT ANNA MINZ)	1	247.20	247.20	247.20	247.20	01
Grand Total:	1	247.20	247.20	247.20	247.20	01

Proposal Basic Information

Proposal File No.	SINPC/BP/0189/W01/2020
Owner Name	ANNA MINZ
Khata No	67
Plot No	2750
Village Name	Gotra
Use	Residential
SubUse	Bungalow/ Dwelling / Non Apartment

AREA STATEMENT SIMDEGA NAGAR PANCHAYAT	VERSION NO: 1.0.66	VERSION DATE: 16/10/2020
PROJECT DETAIL:		
Region: JHARKHAND URBAN LOCAL BODIES	Plot Use: Residential	
District: SIMDEGA	Plot SubUse: Bungalow/ Dwelling / Non Apartment	
Authority: SIMDEGA NAGAR PANCHAYAT	PlotNearbyReligiousStructure: NA	
Inward No: SINPC/BP/0189/W01/2020	PlotSubPlot No: 2750	
Application Type: General Proposal	North: -	
Project Type: Building Permission	South: -	
Nature of Development: New	East: -	
Location of Development Area: Old Area	West: -	
AREA DETAILS:		
AREA OF PLOT (Minimum)	(A)	575.19
Deduction for NetPlot Area		
Surrender Free of Cost		18.36
Total		18.36
NET AREA OF PLOT(Gross Plot Area - Deduction from Gross Plot area)	(A-Deductions)	556.82
Deduction for Balance Plot Area(from Gross Plot Area)		
Surrender Free of Cost		18.36
Common Plot		74.12
Total		92.48
BALANCE AREA OF PLOT(Net Plot Area - Recreational/Amenity space)	(A-Deductions)	462.70
PLOT AREA FOR COVERAGE(Net Plot Area)	(A-Deductions)	556.82
Plot Area for FAR (Net Plot Area + RoadWidening Area)	(A-Deductions)	575.19
COVERAGE CHECK		
Permissible Coverage area (60.00 %)		334.09
Proposed Coverage Area (22.27 %)		123.99
Total Prop. Coverage Area (22.27 %)		123.99
Balance coverage area (37.73 %)		210.10
FAR CHECK		
Perm. FAR Area (1.500)		862.79
Total Perm. FAR area		862.79
Residential FAR		247.20
Proposed FAR Area		247.20
Total Proposed FAR Area		247.20
Consumed FAR (Factor)		0.43
Balance FAR Area		615.59
BUILT UP AREA CHECK		
Total Proposed BuiltUp Area		247.20
ARCHITECT (Regd)		MD RAGIB SAYEED
ENGINEER (Regd)		
SUPERVISOR (Regd)		
OWNER (Regd)		ANNA MINZ
DEVELOPMENT AUTHORITY		LOCAL BODY

COLOR INDEX

PLOT BOUNDARY	Black
ABUTTING ROAD	Green
PROPOSED CONSTRUCTION	Red
COMMON PLOT	Yellow
ROAD WIDENING AREA	Blue
EXISTING (To be retained)	Blue
EXISTING (To be demolished)	Yellow

Buildingwise Floor FAR Details

Floor Name	Building Name A (SMT ANNA MINZ)		Total	
	Proposed Built Up Area (Sq.mt.)	Proposed FAR Area (Sq.mt.)	Total Proposed Built Up Area (Sq.mt.)	Total FAR Area (Sq.mt.)
Ground Floor	123.99	123.99	123.99	123.99
First Floor	123.21	123.21	123.21	123.21
Terrace Floor	0.00	0.00	0.00	0.00
Total:	247.20	247.20	247.20	247.20

Building USE/SUBUSE Details

Building Name	Building Use	Building SubUse	Building Structure
A (SMT ANNA MINZ)	Residential	Bungalow/ Dwelling / Non Apartment	Non-Highrise

SITE PLAN

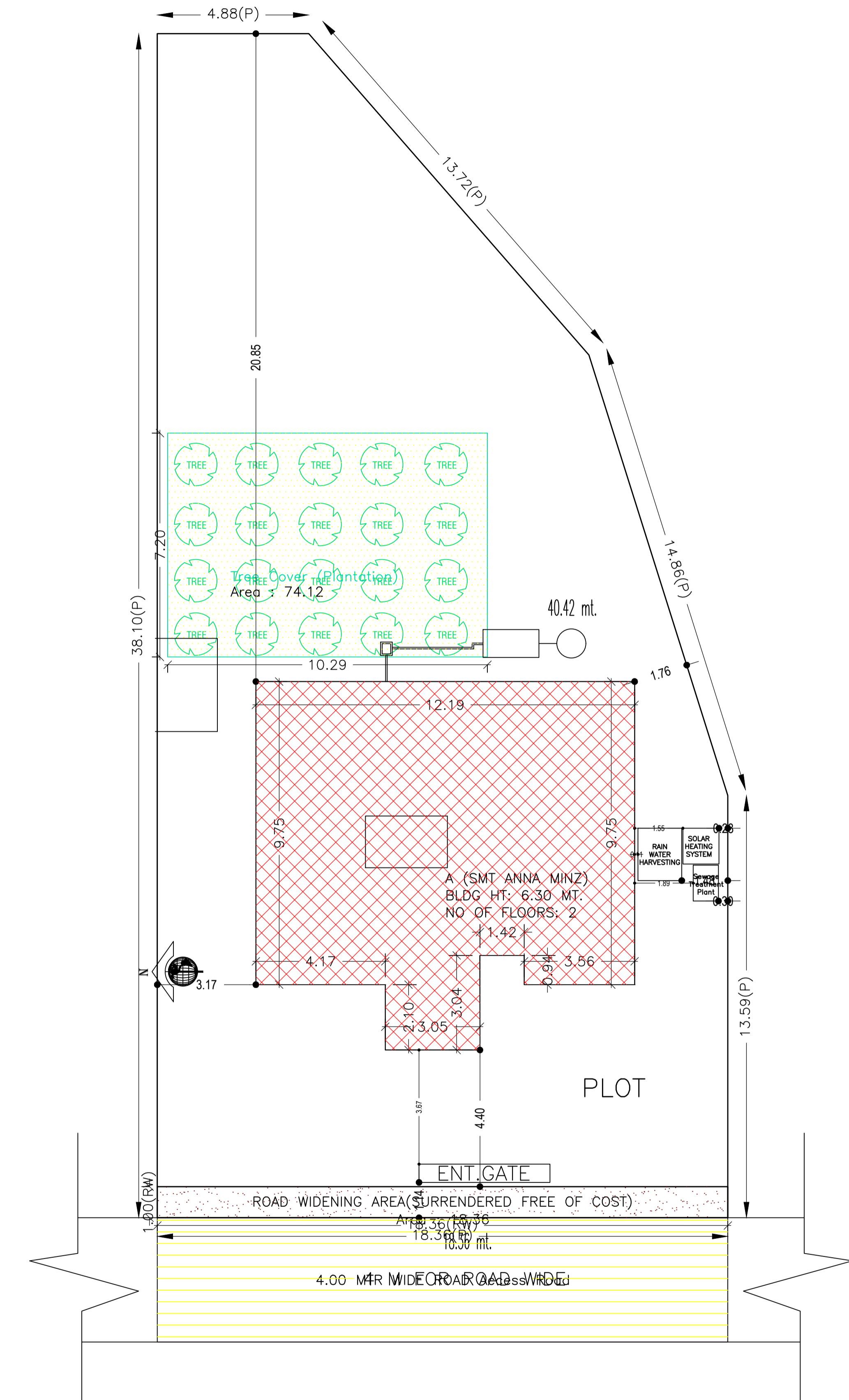

LTP NAME AND SIGNATURE	STRUCTURAL ENG'S NAME AND SIGNATURE	BUILDER NAME AND SIGNATURE	DIGITAL SIGNATURE
MD RAGIB SAYEED SINPC/ENG/0001/2017			

Proposal Basic Information	
Proposal File No.	SINPC/BI/0189/W01/2020
Owner Name	ANNA MINZ
Khata No	67
Plot No	2750
Village Name	Gotra
Use	Residential
SubUse	Bungalow/ Dwelling / Non Apartment

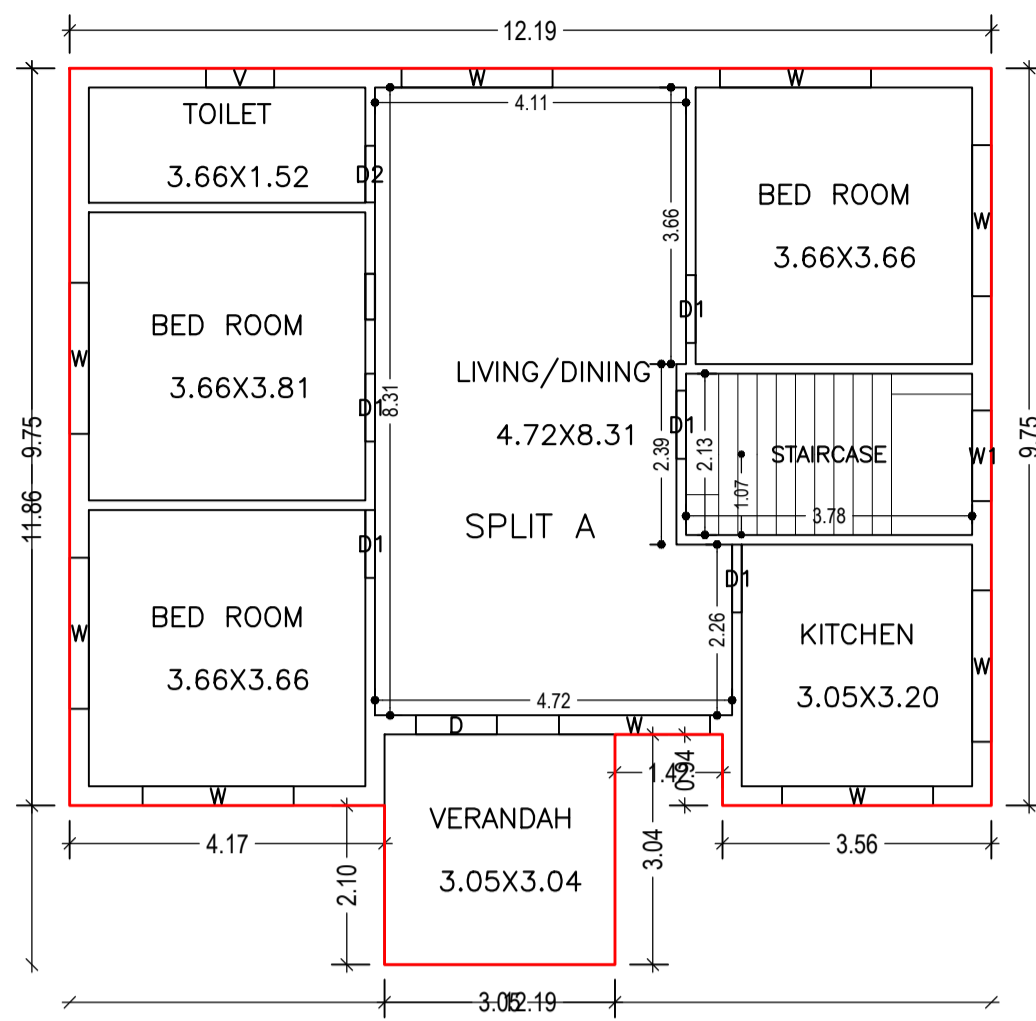

GROUND FLOOR PLAN
(Proposed)
(SCALE 1:100)

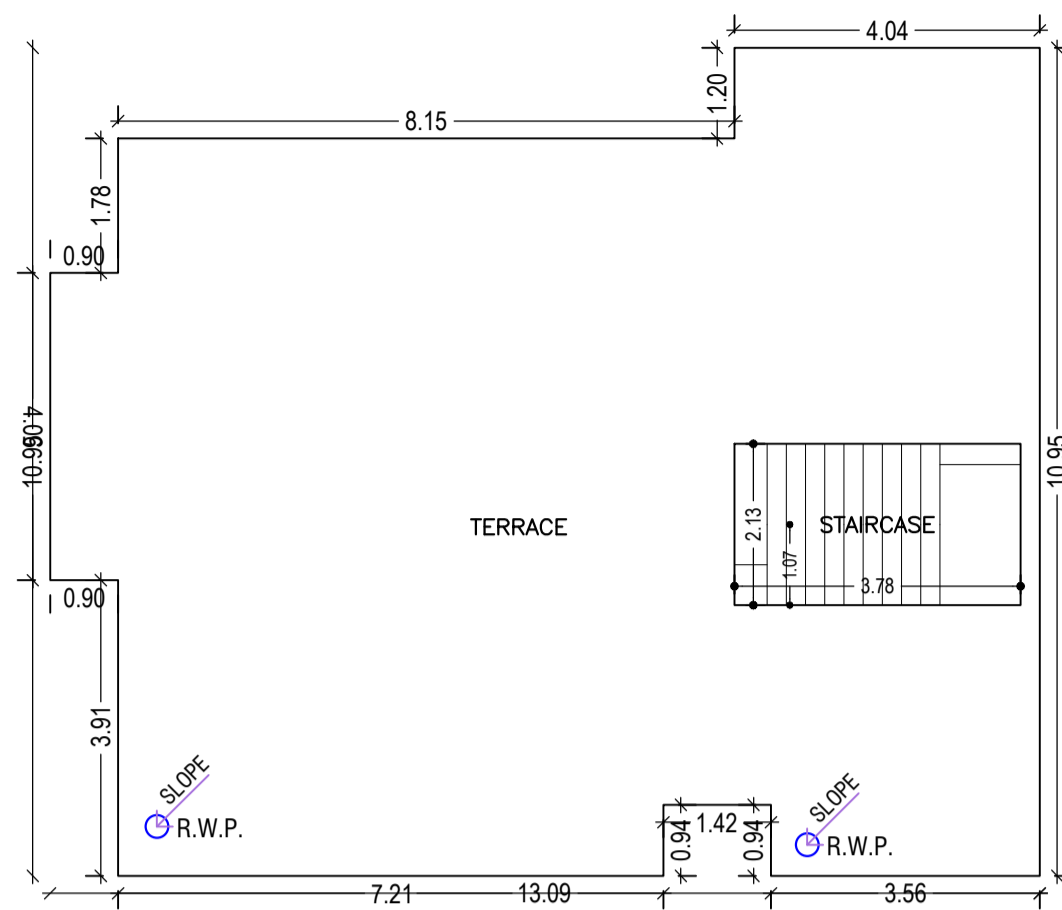

TERRACE FLOOR PLAN
(SCALE 1:100)

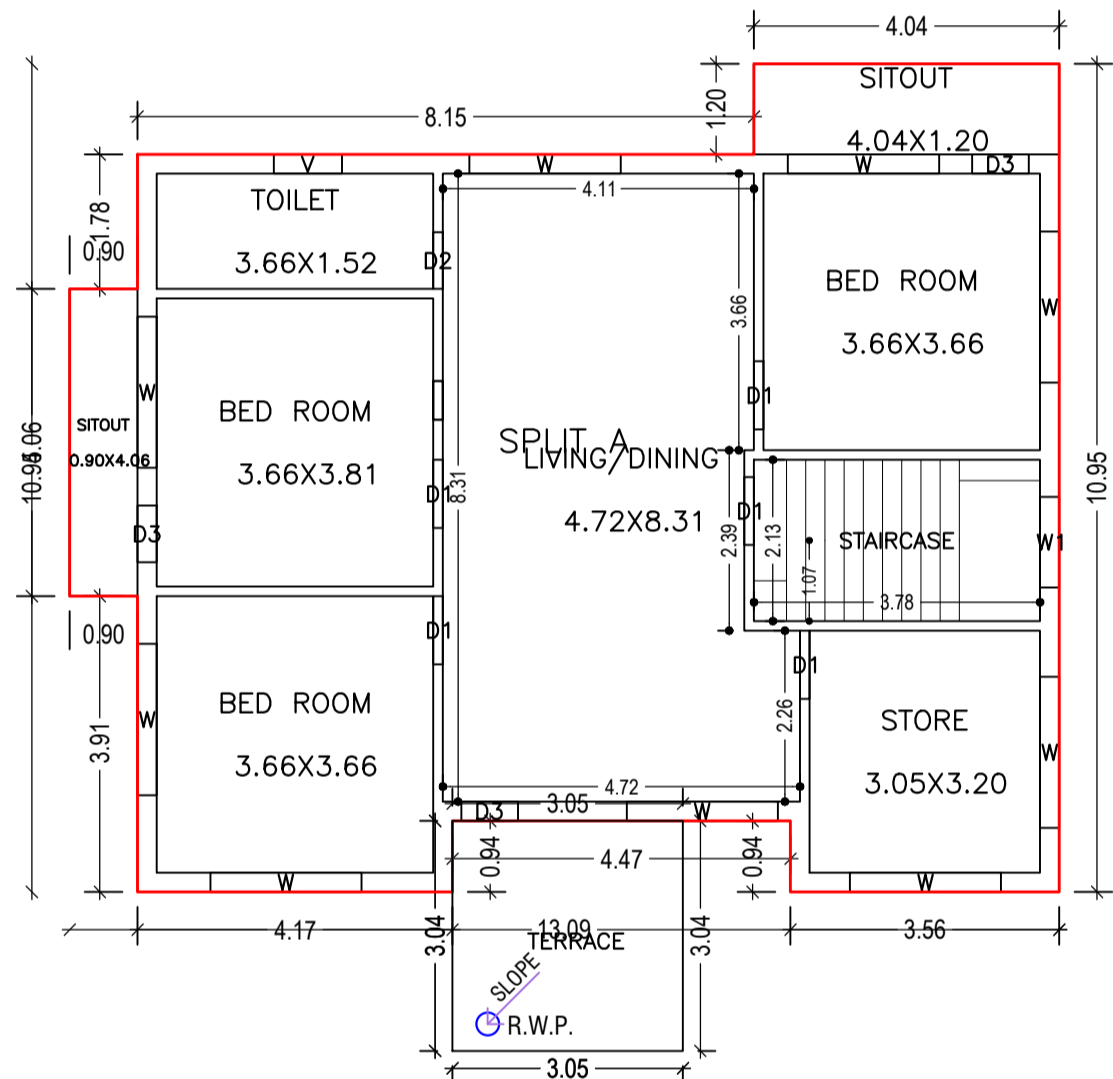

FIRST FLOOR PLAN
(Proposed)
(SCALE 1:100)

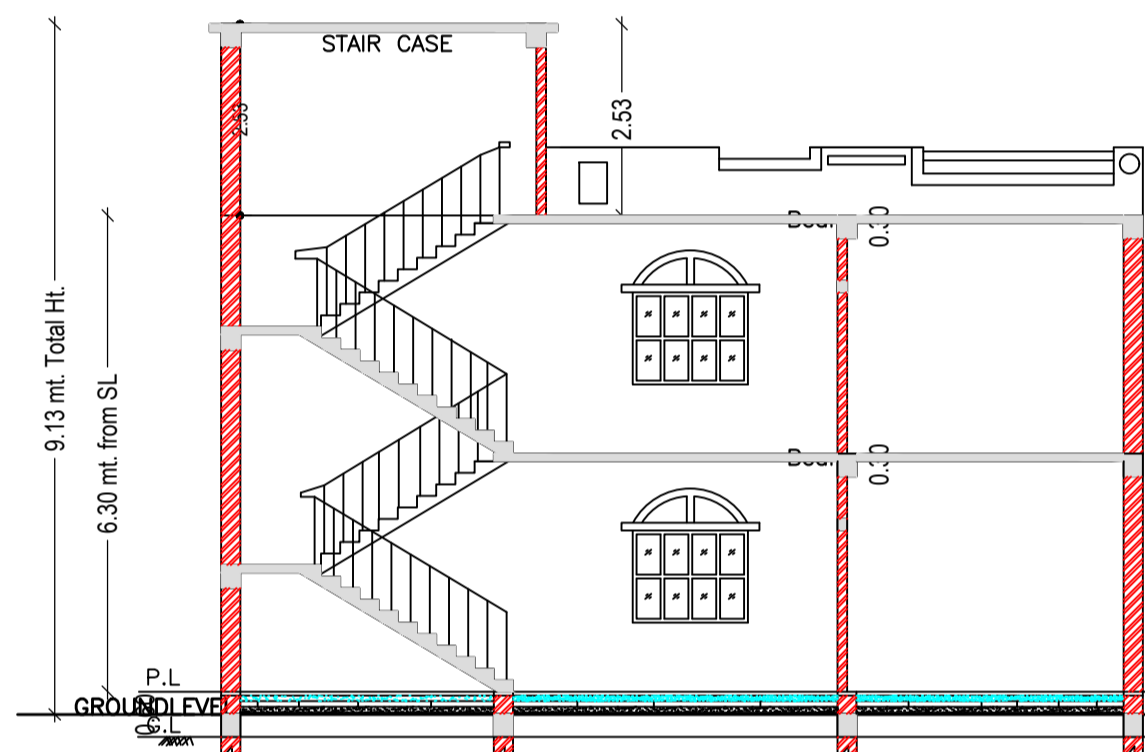

SECTION X-X

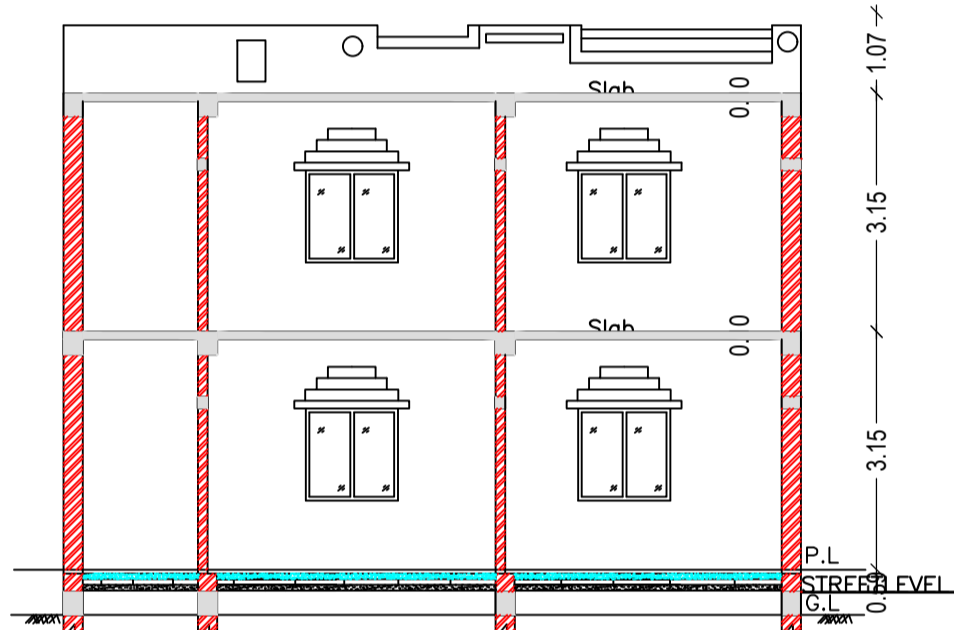

SECTION Y-Y

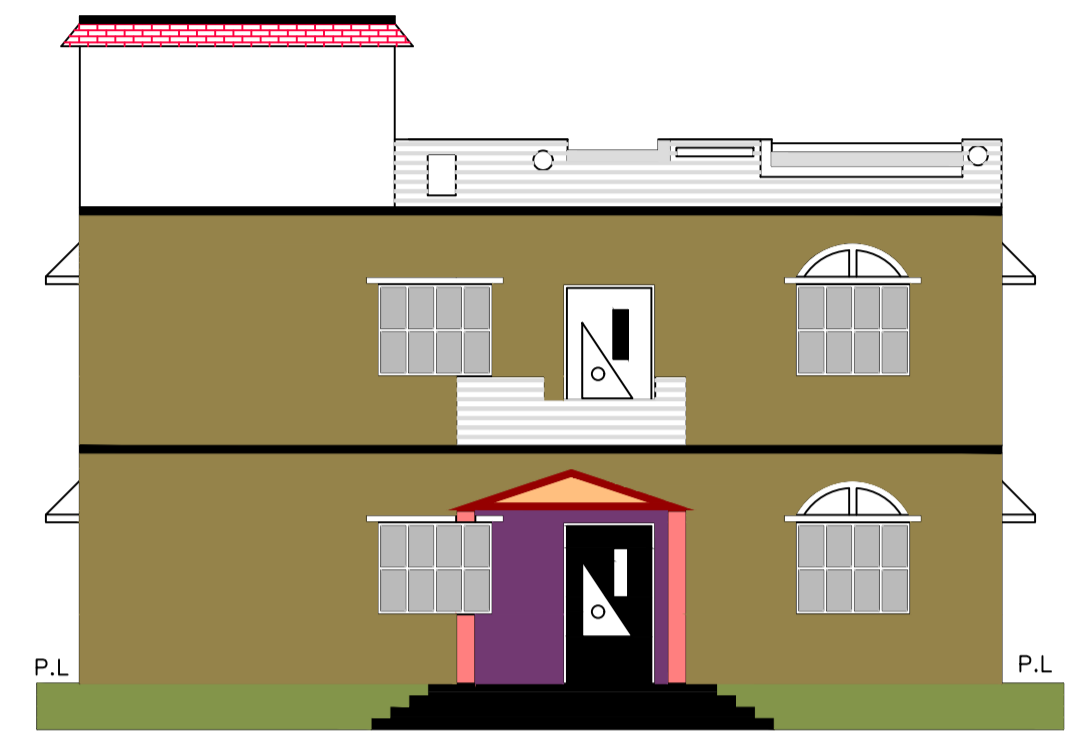

FRONT ELEVATION

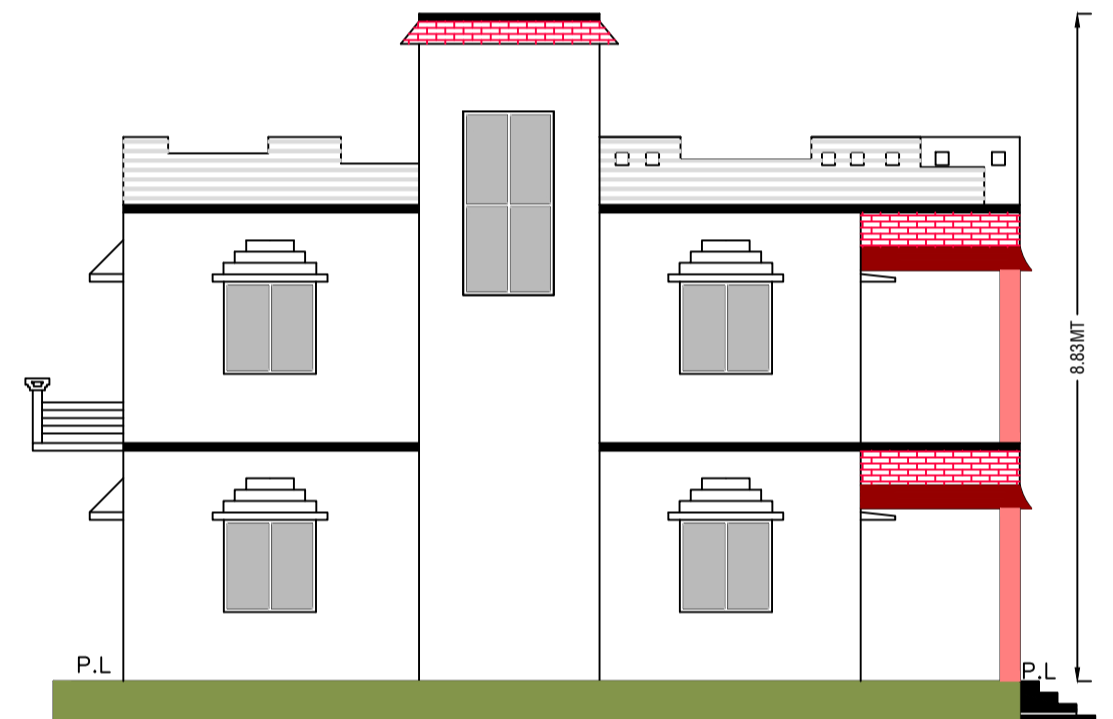

SIDE ELEVATION

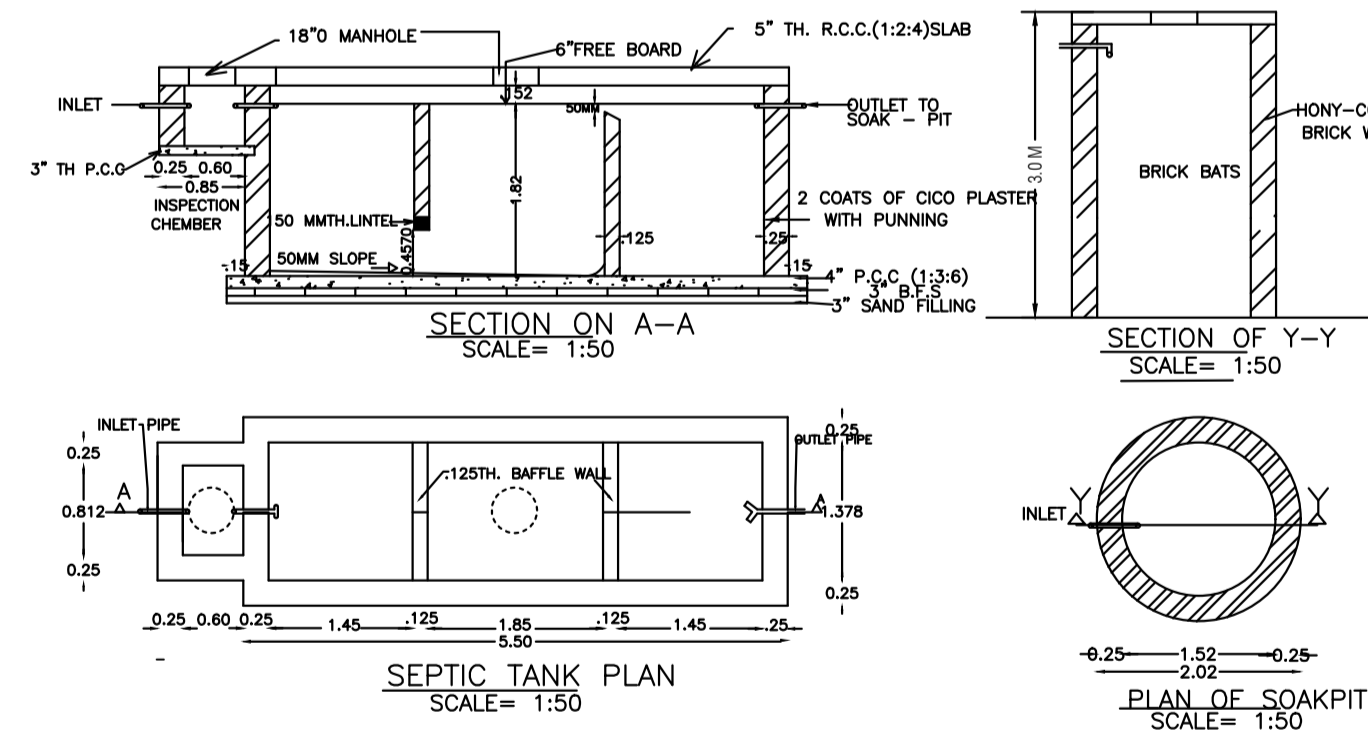

SEPTIC TANK PLAN
SCALE= 1:50

SECTION ON A-A
SCALE= 1:50

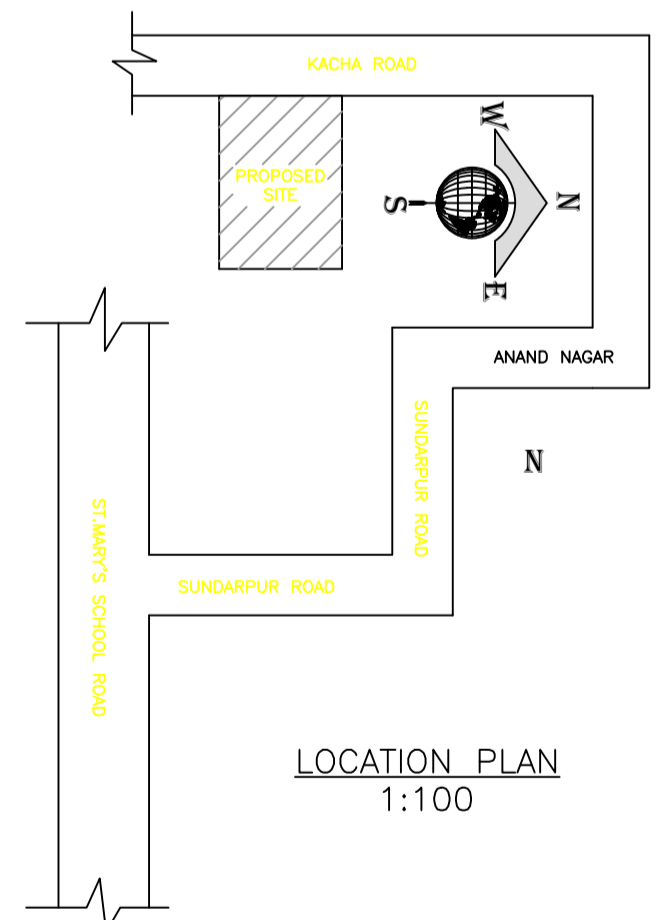

LOCATION PLAN
SCALE= 1:200

SITE PLAN
SCALE= 1:200

Building :A (SMT ANNA MINZ)

Floor Name	Total Built Up Area (Sq.mt.)	Proposed FAR Area (Sq.mt.)	Total FAR Area (Sq.mt.)	Total Consumed Additional FAR Area (Sq.mt.)	Tnmt (No.)
Ground Floor	123.99	123.99	123.99	123.99	01
First Floor	123.21	123.21	123.21	123.21	00
Terrace Floor	0.00	0.00	0.00	0.00	00
Total :	247.20	247.20	247.20	247.20	01
Total Number of Same Buildings	1				
Total :	247.20	247.20	247.20	247.20	01

SCHEDULE OF DOOR:

BUILDING NAME	NAME	LENGTH	HEIGHT	NOS
A (SMT ANNA MINZ)	D3	0.75	2.13	03
A (SMT ANNA MINZ)	D2	0.75	2.13	02
A (SMT ANNA MINZ)	D1	0.90	2.13	10
A (SMT ANNA MINZ)	D	1.07	2.13	01

SCHEDULE OF WINDOW/VENTILATION:

BUILDING NAME	NAME	LENGTH	HEIGHT	NOS
A (SMT ANNA MINZ)	V	0.90	2.70	02
A (SMT ANNA MINZ)	W1	1.20	2.70	02
A (SMT ANNA MINZ)	W	2.00	2.70	18

UnitBUA Table for Building :A (SMT ANNA MINZ)

FLOOR	Name	UnitBUA Type	UnitBUA Area	Carpet Area	No. of Rooms	No. of Tenement
GROUND FLOOR PLAN	SPLIT A	FLAT	208.79	208.65	7	1
FIRST FLOOR PLAN	SPLIT A	FLAT	0.00	0.00	8	0
Total:	-	-	208.79	208.65	15	1

LTP NAME AND SIGNATURE	STRUCTURAL ENG'S NAME AND SIGNATURE	BUILDER NAME AND SIGNATURE	DIGITAL SIGNATURE
MD RAGIB SAYEED SINPC/ENG/0001/2017			

Proposal Basic Information	
Proposal File No.	SINPC/BP/0189/W01/2020
Owner Name	ANNA MINZ
Khata No	67
Plot No	2750
Village Name	Gotra
Use	Residential
SubUse	Bungalow/ Dwelling / Non Apartment

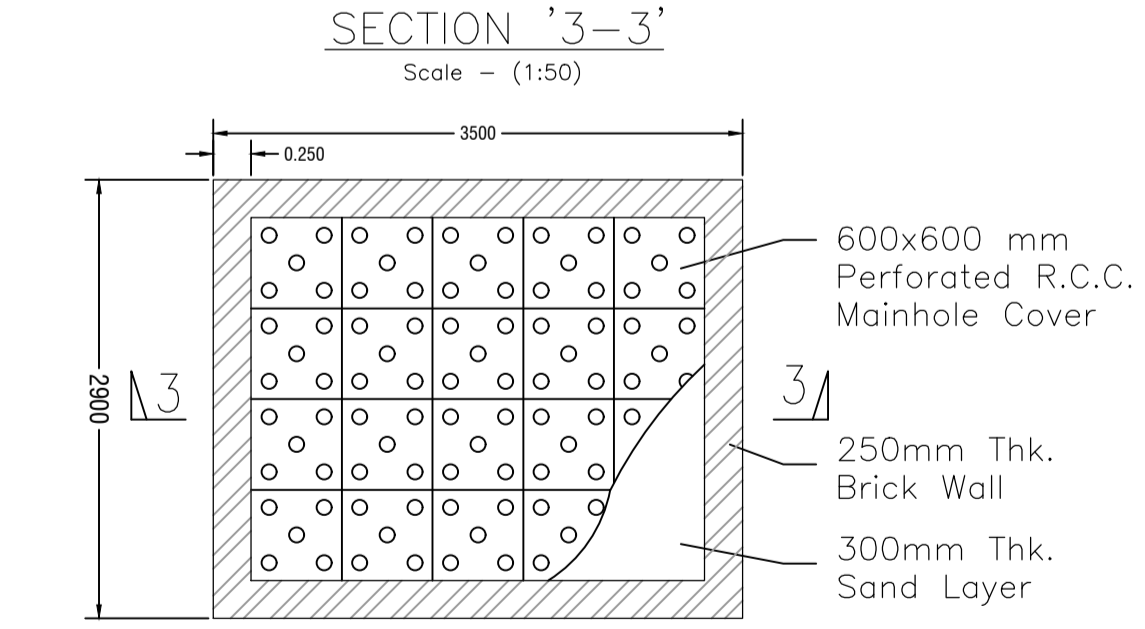
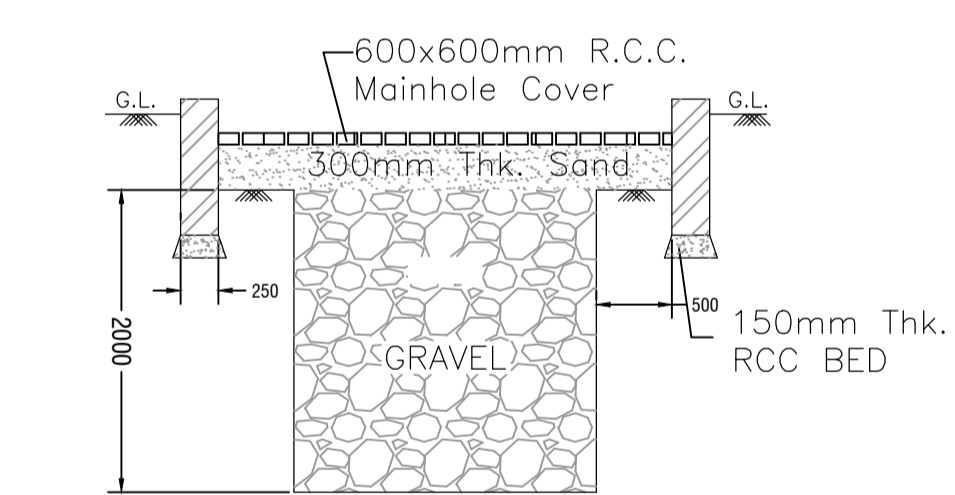
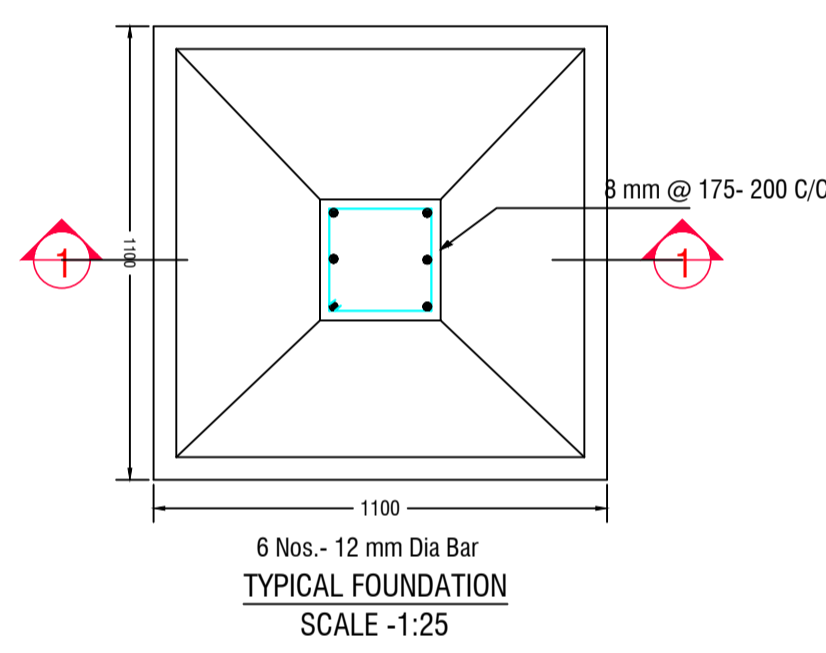
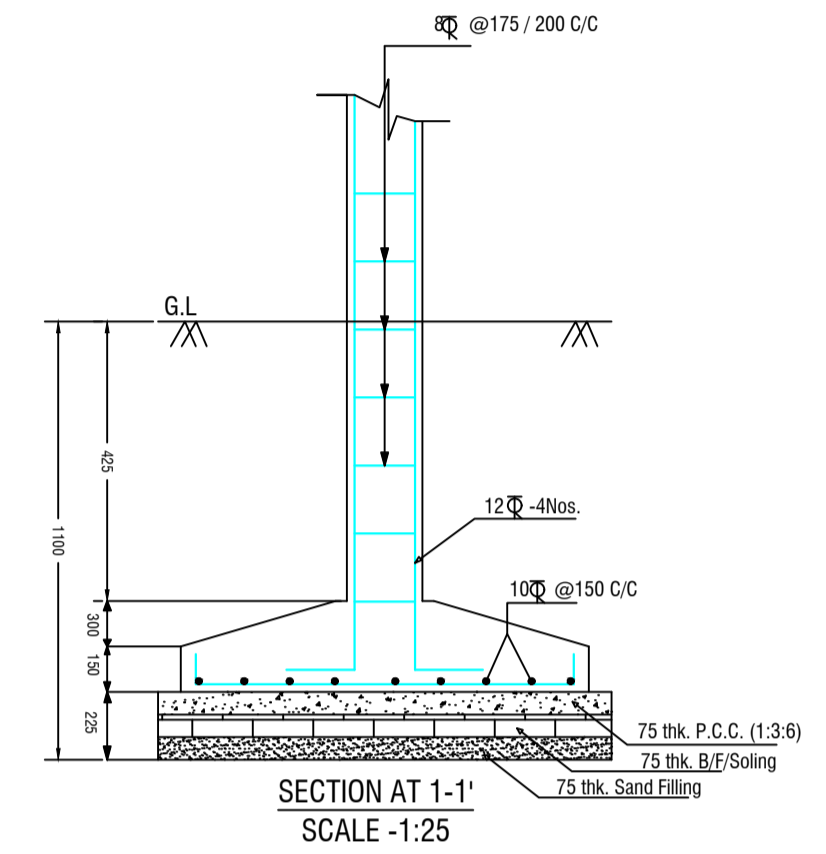

PLAN OF RAIN WATER RECHARGE PIT
Scale - (1:50)

LTP NAME AND SIGNATURE	STRUCTURAL ENG'S NAME AND SIGNATURE	BUILDER NAME AND SIGNATURE	DIGITAL SIGNATURE
MD RAGIB SAYEED SINPC/ENG/0001/2017			