

FAR & Tenement Details (Table 4c-1)

Building	No. of Same Bldg	Total Built Up Area (Sq.mt.)	Proposed FAR Area (Sq.mt.) Resi.	Total FAR Area (Sq.mt.)	Total Consumed Additional FAR Area (Sq.mt.)	Tnmt (No.)
A1 (RESIDENSE)	1	553.59	553.59	553.59	553.59	02
Grand Total	1	553.59	553.59	553.59	553.59	02

Proposal Basic Information

Proposal File No.	SINPC/BP/0240/W12/2021
Owner Name	SUJATA DEVI
Khata No	141
Plot No	148
Village Name	Simdega
Use	Residential
SubUse	Bungalow/ Dwelling / Non Apartment

AREA STATEMENT SIMDEGA NAGAR PANCHAYAT		VERSION NO.: 1.0.60
PROJECT DETAIL:		VERSION DATE: 16/10/2020
Region: JHARKHAND URBAN LOCAL BODIES	Plot Use: Residential	
District: SIMDEGA	Plot SubUse: Bungalow/ Dwelling / Non Apartment	
Authority: SIMDEGA NAGAR PANCHAYAT	PlotNearbyReligiousStructure: NA	
Inward No: SINPC/BP/0240/W12/2021	Plot/SubPlot No: 148	
Application Type: General Proposal	North: -	
Project Type: Building Permission	South: -	
Nature of Development: New	East: -	
Location of Development Area: Old Area	West: -	
AREA DETAILS:		
AREA OF PLOT (Minimum)	(A)	SQ.MT. 403.54
NET AREA OF PLOT(Gross Plot Area - Deduction from Gross Plot area)	(A-Deductions)	403.54
Deduction for Balance Plot Area(from Gross Plot Area)		
Common Plot		25.90
Total		25.90
BALANCE AREA OF PLOT(Net Plot Area - Recreational/Amenity space)	(A-Deductions)	377.64
PLOT AREA FOR COVERAGE(Net Plot Area)	(A-Deductions)	403.54
Plot Area for FAR (Net Plot Area + Road Widening Area)	(A-Deductions)	403.54
COVERAGE CHECK		
Permissible Coverage area (60.00 %)		242.12
Proposed Coverage Area (45.73 %)		184.53
Total Prop. Coverage Area (45.73 %)		184.53
Balance coverage area (14.27 %)		57.59
FAR CHECK		
Perm. FAR Area (1.50)		605.31
Total Perm. FAR area		605.31
Residential FAR		553.59
Proposed FAR Area		553.59
Total Proposed FAR Area		553.59
Consumed FAR (Factor)		1.37
Balance FAR Area		51.72
BUILT UP AREA CHECK		
Total Proposed BuiltUp Area		553.59
ARCHITECT (Regd)		RAM RATAN SINGH
ENGINEER (Regd)		
SUPERVISOR (Regd)		
OWNER (Regd)		SUJATA DEVI
DEVELOPMENT AUTHORITY		LOCAL BODY

COLOR INDEX	
PLOT BOUNDARY	[Red Line]
ABUTTING ROAD	[Green Line]
PROPOSED CONSTRUCTION	[Yellow Area]
COMMON PLOT	[Blue Area]
ROAD WIDENING AREA	[Orange Area]
EXISTING (To be retained)	[Light Blue Area]
EXISTING (To be demolished)	[Dark Blue Area]

SITE PLAN

Required Parking (Table 7a)

Building Name	Type	SubUse	Area (Sq.mt.)	Units		Car		Visitors Car		TwoWheeler		
				Reqd.	Prop.	Reqd./Unit	Reqd.	Prop.	Reqd./Unit	Reqd.	Prop.	Reqd./Unit
A1 (RESIDENSE)	Residential	Bungalow/ Dwelling / Non Apartment	>0	1	2.00	1	2	-	-	-	-	-
Total :			>0	1	2.00	-	2	2	-	1	2	-

Parking Check (Table 7b)

Vehicle Type	Reqd.		Prop.	
	No.	Area	No.	Area
Car	-	-	2	25.00
Total Car	2	25.00	2	25.00
Visitor's Car Parking	-	-	2	25.00
Total Visitor Parking	1	12.50	2	25.00
TwoWheeler	-	-	4	10.00
Total TwoWheeler	-	-	4	10.00
Total		37.50		70.00

Buildingwise Floor FAR Details

Floor Name	Building Name A1 (RESIDENSE)		Total	
	Proposed Built Up Area (Sq.mt.)	Proposed FAR Area (Sq.mt.)	Total Proposed Built Up Area (Sq.mt.)	Total FAR Area (Sq.mt.)
Ground Floor	184.53	184.53	184.53	184.53
First Floor	184.53	184.53	184.53	184.53
Second Floor	184.53	184.53	184.53	184.53
Terrace Floor	0.00	0.00	0.00	0.00
Total :	553.59	553.59	553.59	553.59

Building USE/SUBUSE Details

Building Name	Building Use	Building SubUse	Building Structure
A1 (RESIDENSE)	Residential	Bungalow/ Dwelling / Non Apartment	Non-Highrise

LTP NAME AND SIGNATURE	STRUCTURAL ENG'S NAME AND SIGNATURE	BUILDER NAME AND SIGNATURE	DIGITAL SIGNATURE
RAM RATAN SINGH SINPC/DFTMN/0003/2020			

Proposal Basic Information	
Proposal File No.	SINPC/BP/0240/W12/2021
Owner Name	SUJATA DEVI
Khata No	141
Plot No	148
Village Name	Simdega
Use	Residential
SubUse	Bungalow/ Dwelling / Non Apartment

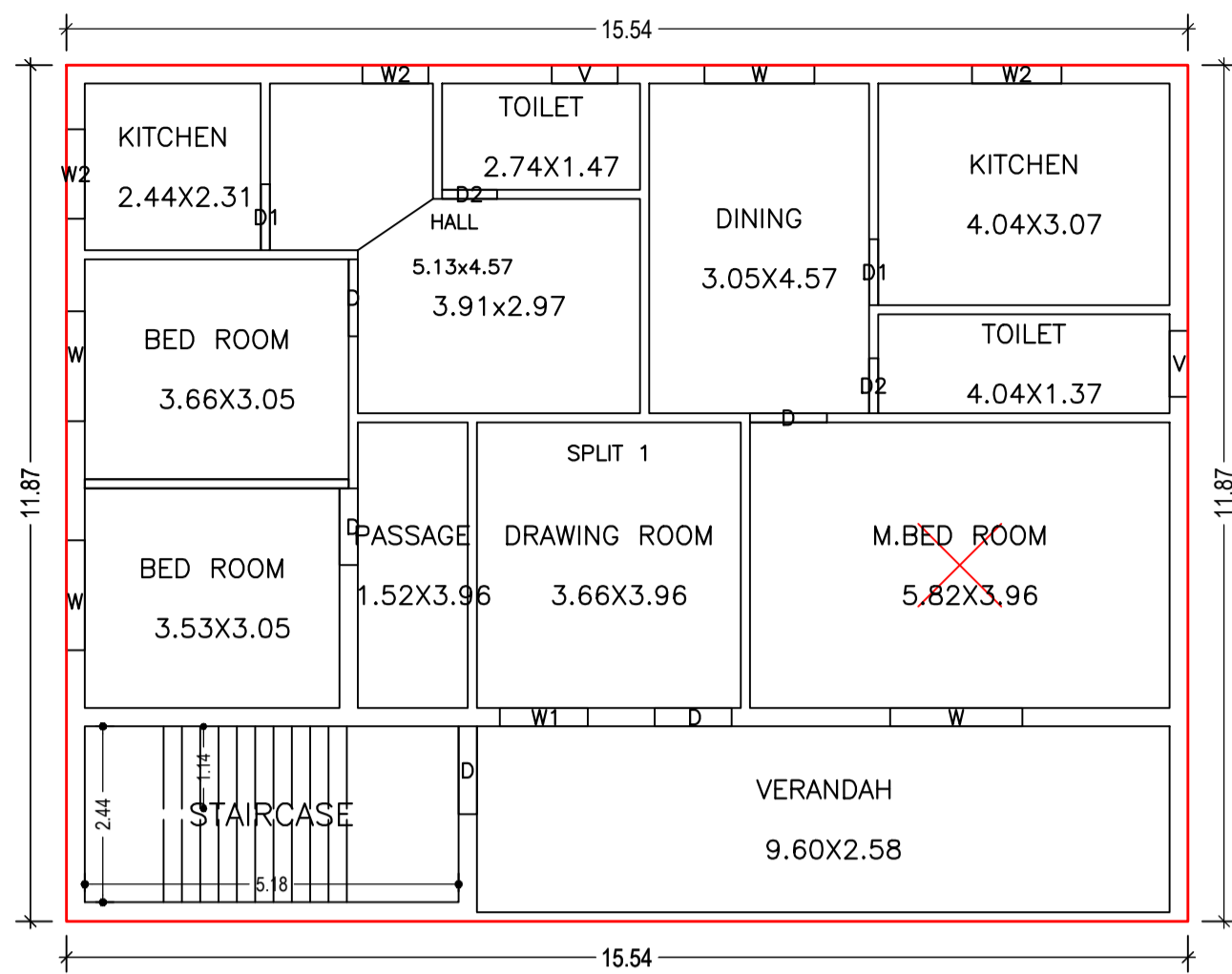

GROUND FLOOR PLAN (Proposed) (SCALE 1:100)

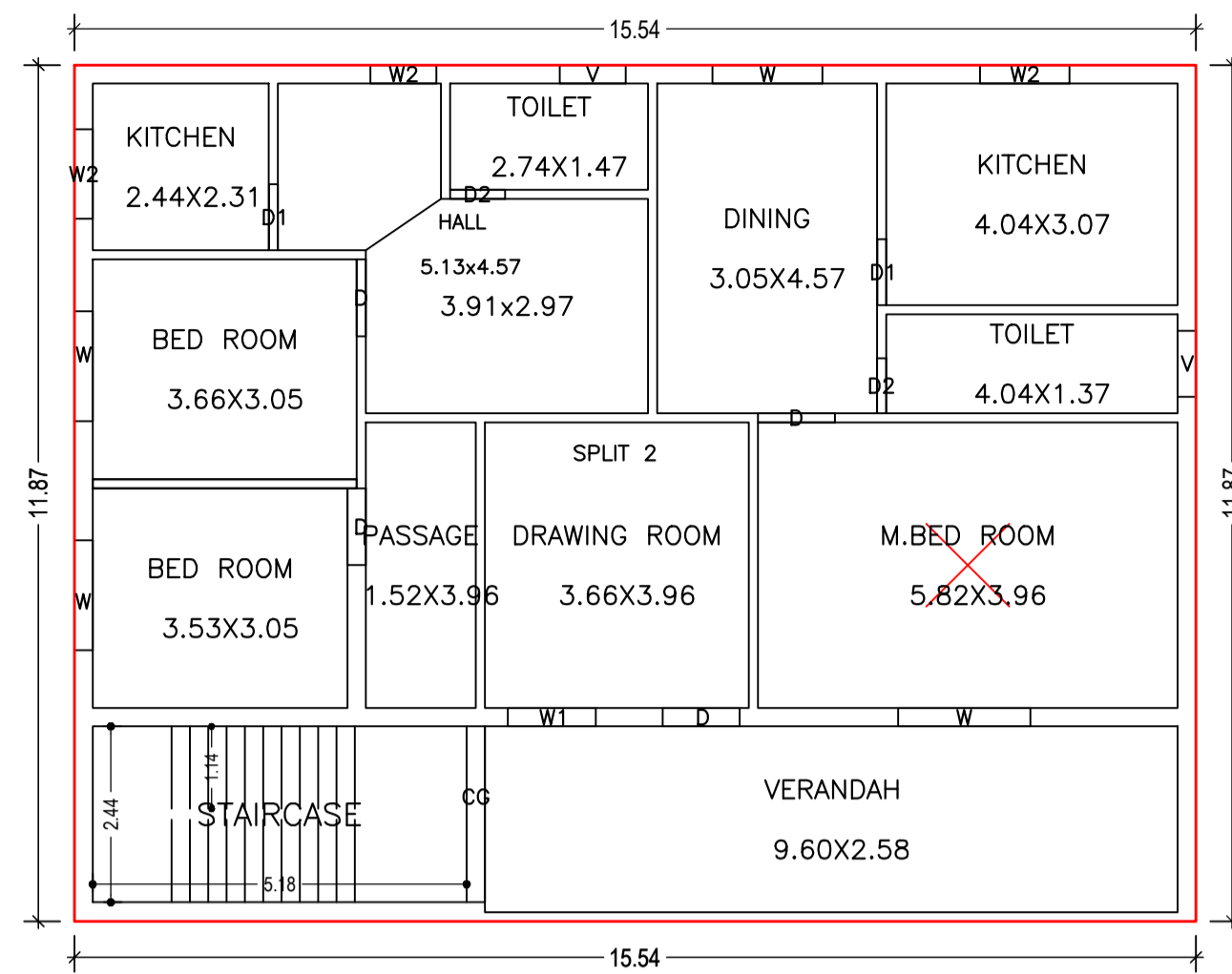

SECOND FLOOR PLAN (Proposed) (SCALE 1:100)

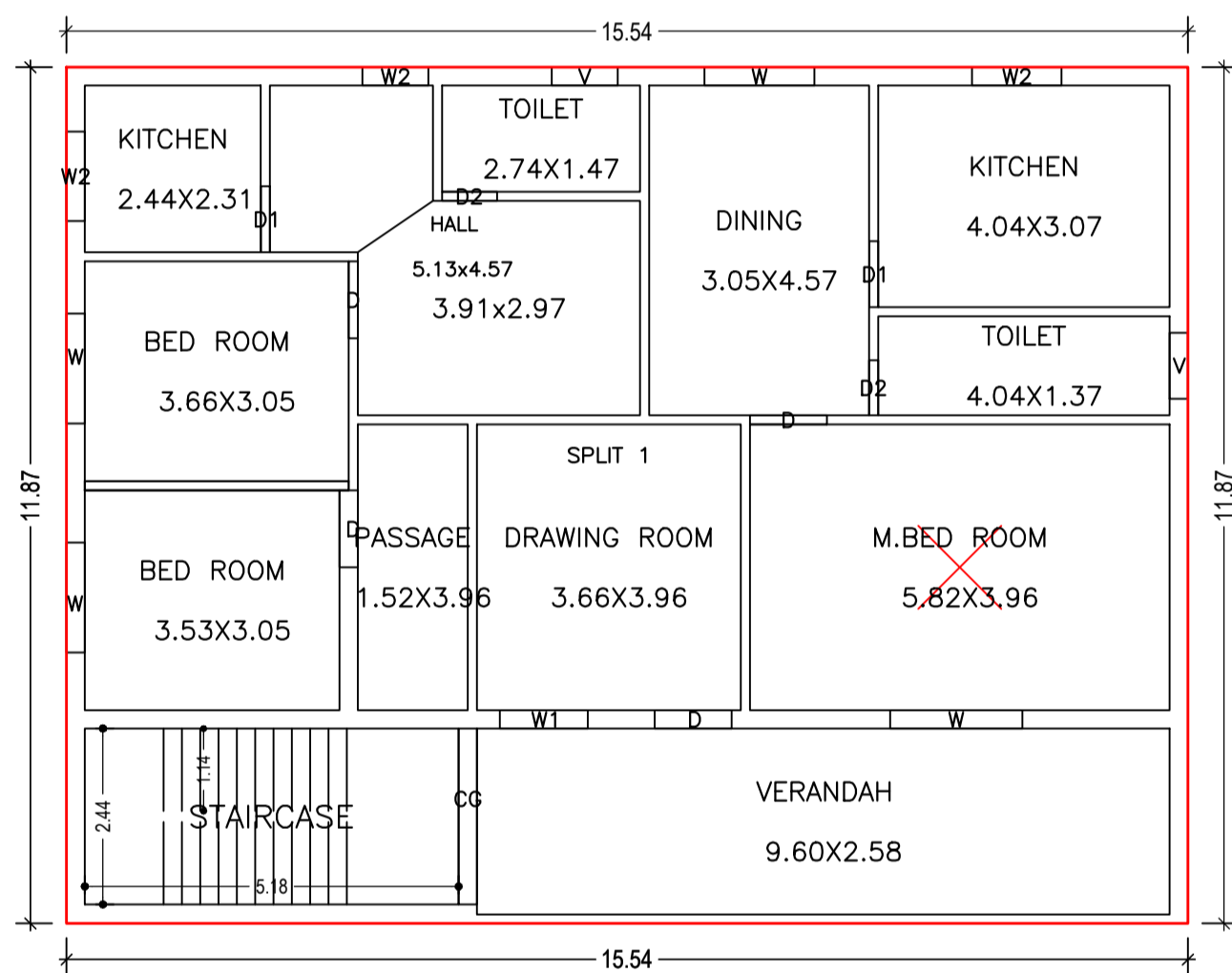

FIRST FLOOR PLAN (Proposed) (SCALE 1:100)

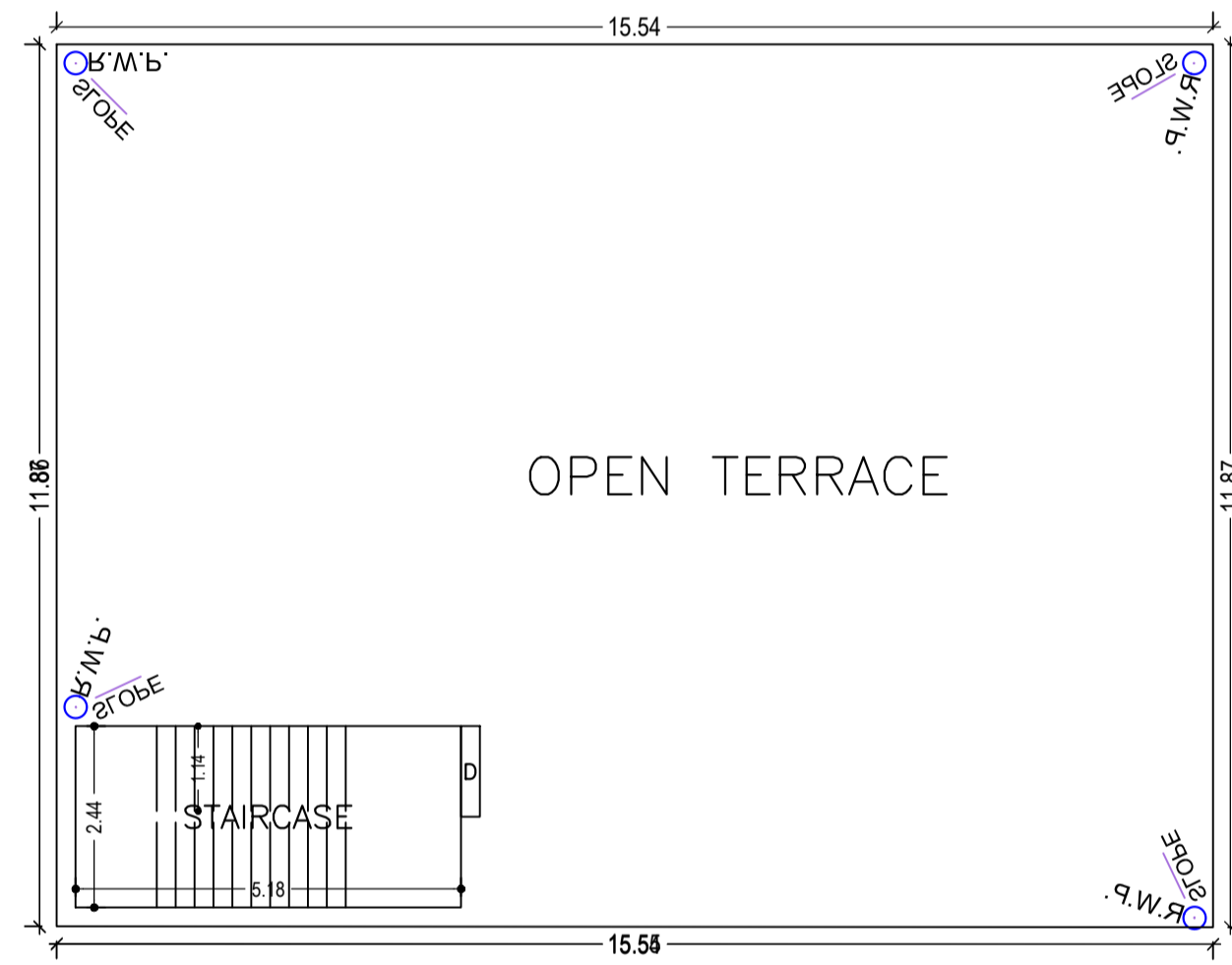

TERRACE FLOOR PLAN (SCALE 1:100)

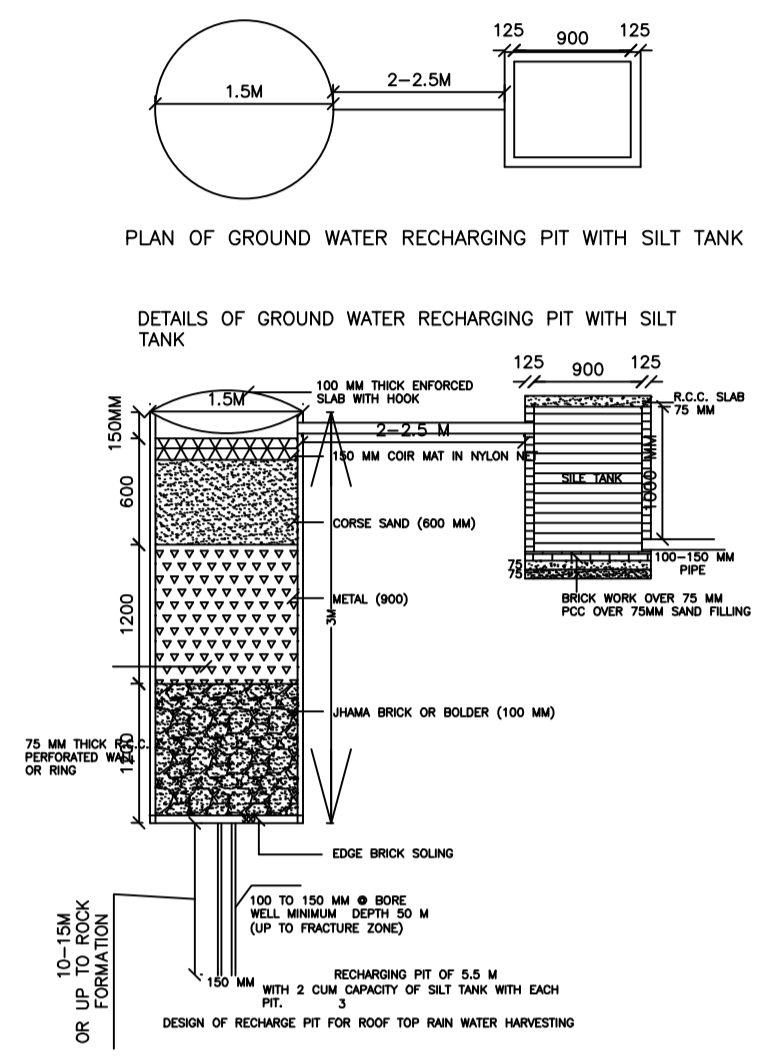

PLAN OF GROUND WATER RECHARGING PIT WITH SILT TANK

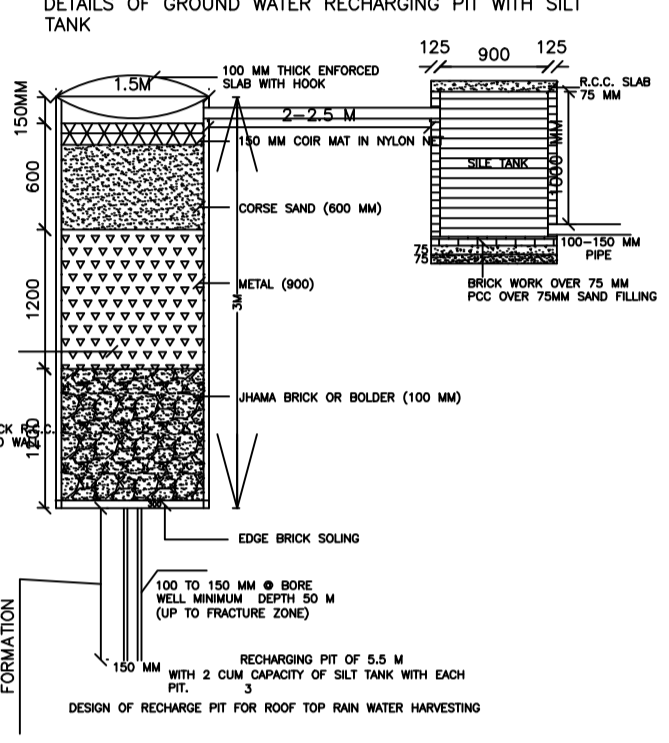

DETAILS OF GROUND WATER RECHARGING PIT WITH SILT TANK

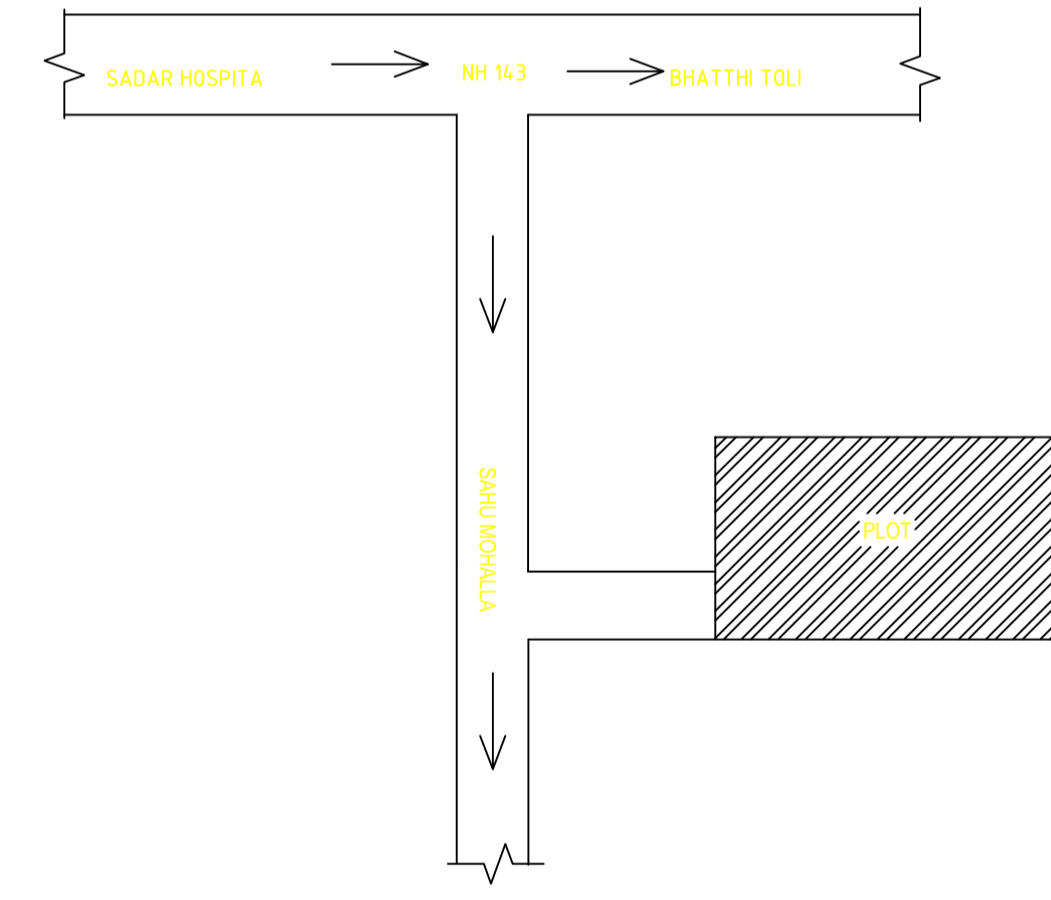

LOCATION PLAN NOT TO SCALE

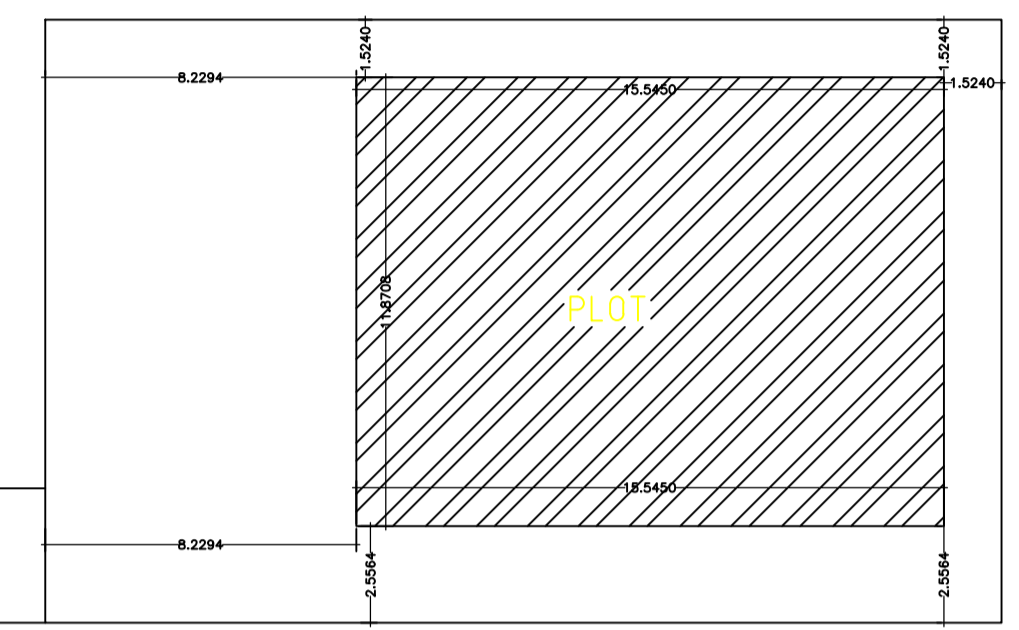

KEY PLAN SCALE 1:200

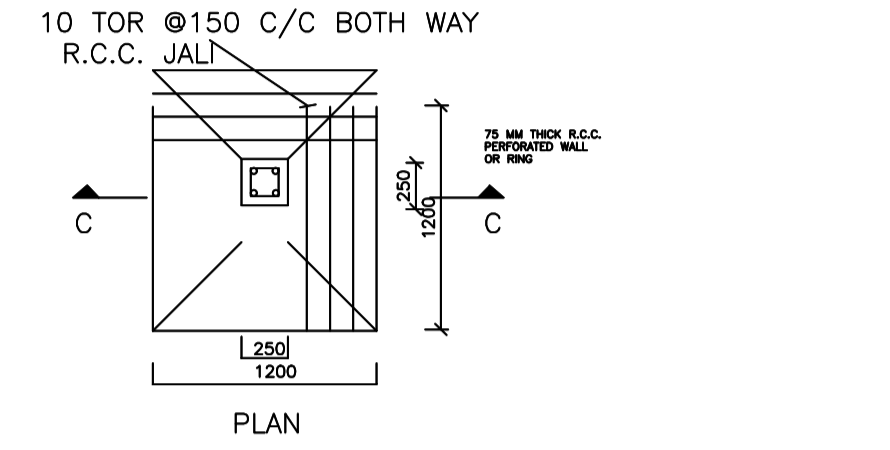

DETAIL OF FOUNDATION

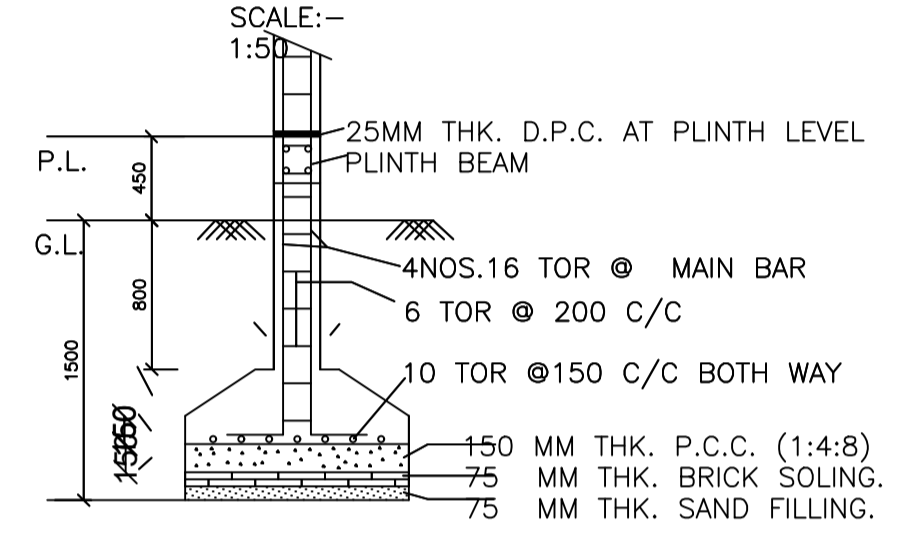

SECTION -CC

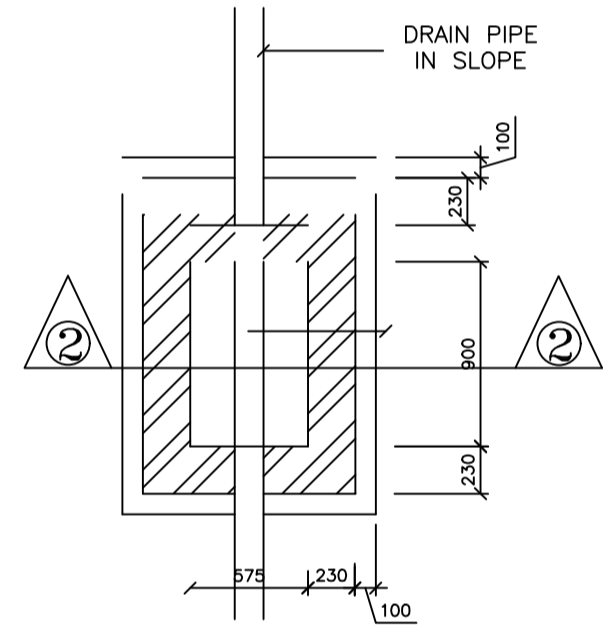

PLAN I.C. DETAILS

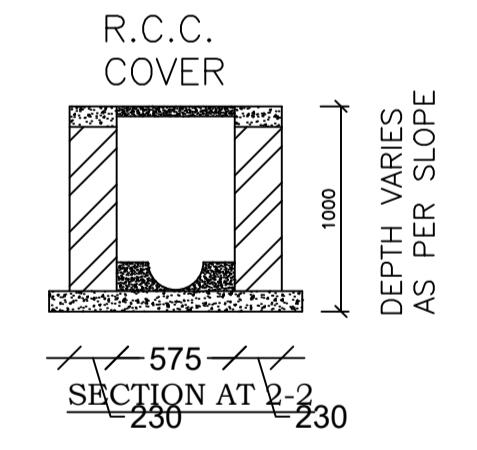

SECTION AT 2-2

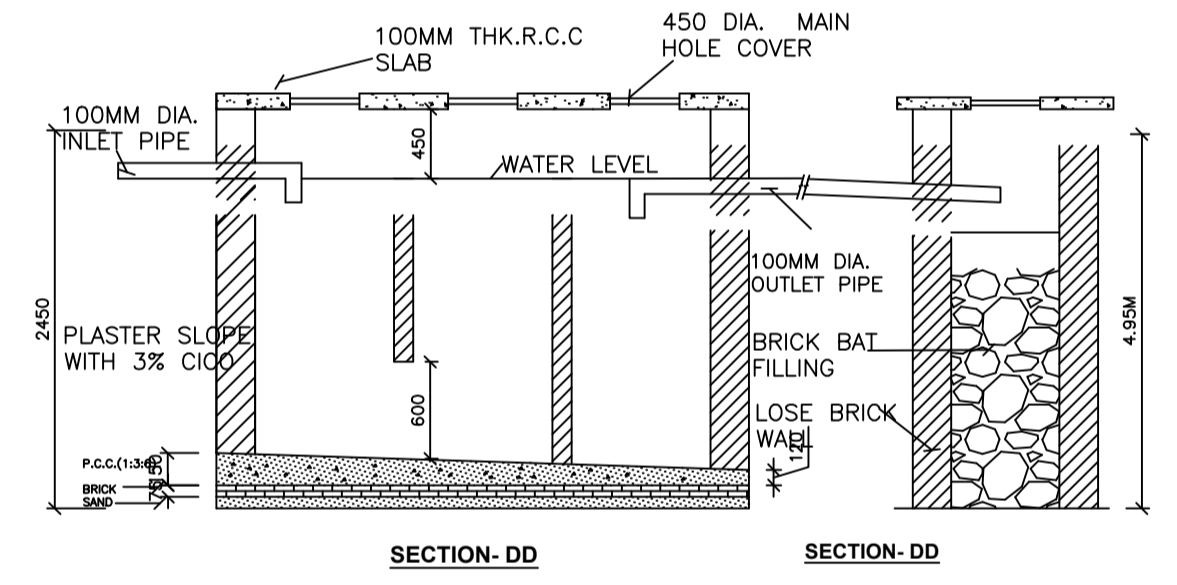

SECTION-DD

SECTION-DD

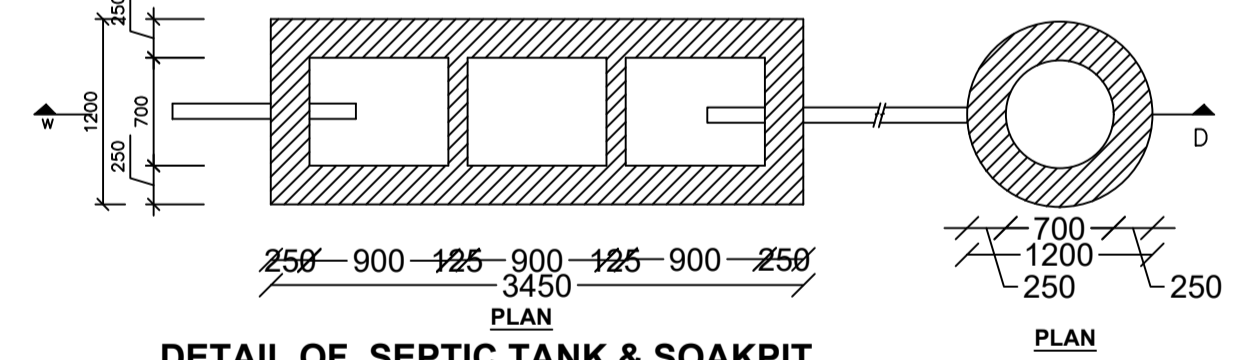

DETAIL OF SEPTIC TANK & SOAKPIT.

PLAN SCALE - 1:50

SCHEDULE OF DOOR:

BUILDING NAME	NAME	LENGTH	HEIGHT	NOS
A1 (RESIDENSE)	D2	0.76	2.10	06
A1 (RESIDENSE)	D1	0.91	2.10	06
A1 (RESIDENSE)	D	1.07	2.10	12
A1 (RESIDENSE)	D	1.22	2.10	01
A1 (RESIDENSE)	CG	2.44	2.10	02

SCHEDULE OF WINDOW/VENTILATION:

BUILDING NAME	NAME	LENGTH	HEIGHT	NOS
A1 (RESIDENSE)	V	0.91	1.20	06
A1 (RESIDENSE)	W2	0.91	1.20	03
A1 (RESIDENSE)	W1	1.22	1.20	03
A1 (RESIDENSE)	W2	1.24	1.20	06
A1 (RESIDENSE)	W	1.52	1.20	09
A1 (RESIDENSE)	W	1.83	1.20	03

UnitBUA Table for Building :A1 (RESIDENSE)

FLOOR	Name	UnitBUA Type	UnitBUA Area	Carpet Area	No. of Rooms	No. of Tenement
SECOND FLOOR PLAN	SPLIT 2	FLAT	157.41	156.95	12	1
FIRST FLOOR PLAN	SPLIT 1	FLAT	0.00	0.00	12	0
GROUND FLOOR PLAN	SPLIT 1	FLAT	314.82	313.89	12	1
Total:	-	-	472.23	470.84	36	2

Building :A1 (RESIDENSE)

Floor Name	Total Built Up Area (Sq.mt.)	Proposed FAR Area (Sq.mt.)	Total FAR Area (Sq.mt.)	Total Consumed Additional FAR Area (Sq.mt.)	Tnmt (No.)
Ground Floor	184.53	184.53	184.53	184.53	01
First Floor	184.53	184.53	184.53	184.53	00
Second Floor	184.53	184.53	184.53	184.53	01
Terrace Floor	0.00	0.00	0.00	0.00	00
Total:	553.59	553.59	553.59	553.59	02
Total Number of Same Buildings	1				
Total:	553.59	553.59	553.59	553.59	02

LTP NAME AND SIGNATURE	STRUCTURAL ENG'S NAME AND SIGNATURE	BUILDER NAME AND SIGNATURE	DIGITAL SIGNATURE
RAM RATAN SINGH SINPC/DFTMN/0003/2020			

Proposal Basic Information	
Proposal File No.	SINPC/BP/0240/W12/2021
Owner Name	SUJATA DEVI
Khata No	141
Plot No	148
Village Name	Simdega
Use	Residential
SubUse	Bungalow/ Dwelling / Non Apartment

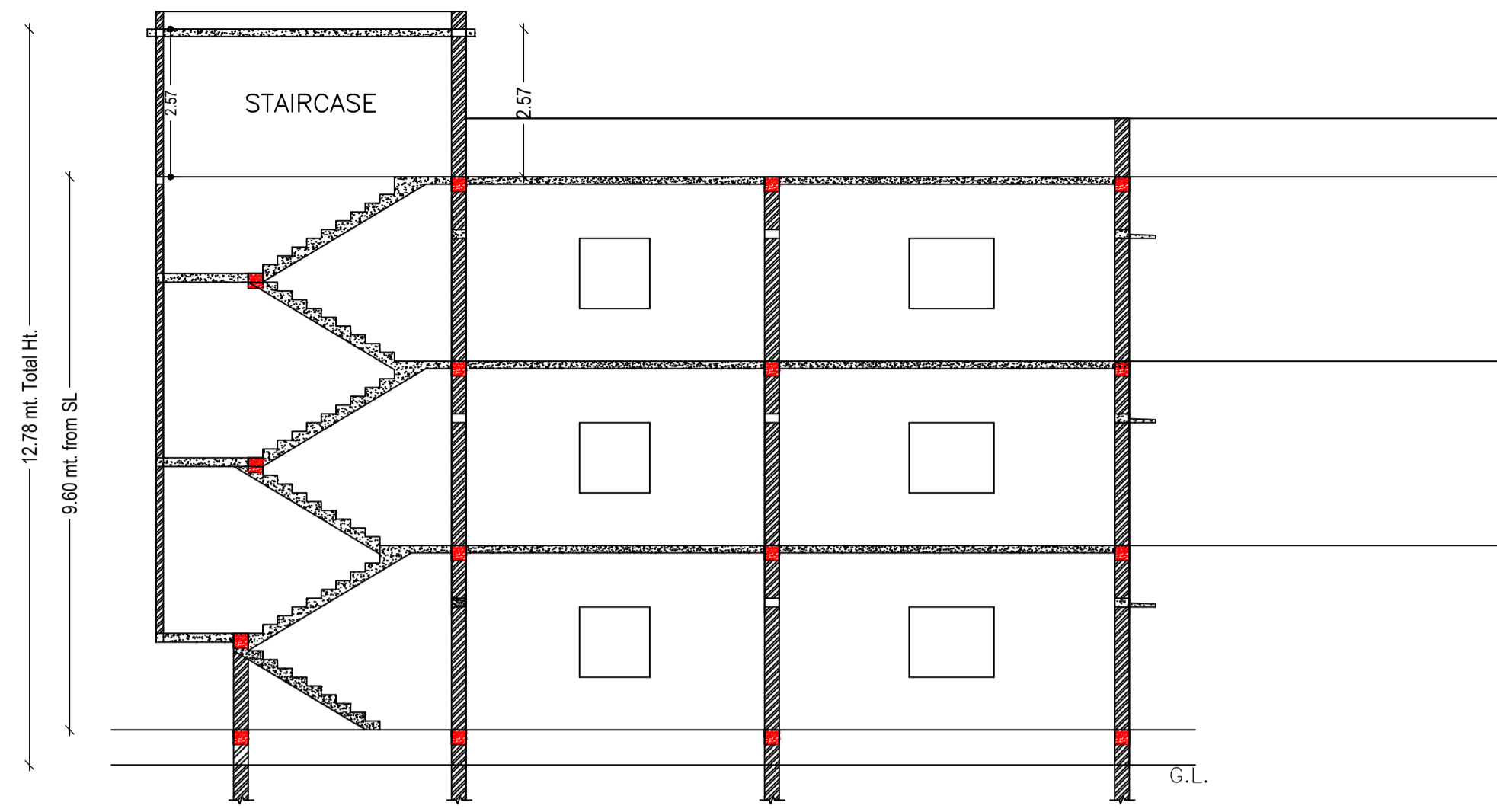

SECTION AT-X-X
SCALE 1:100

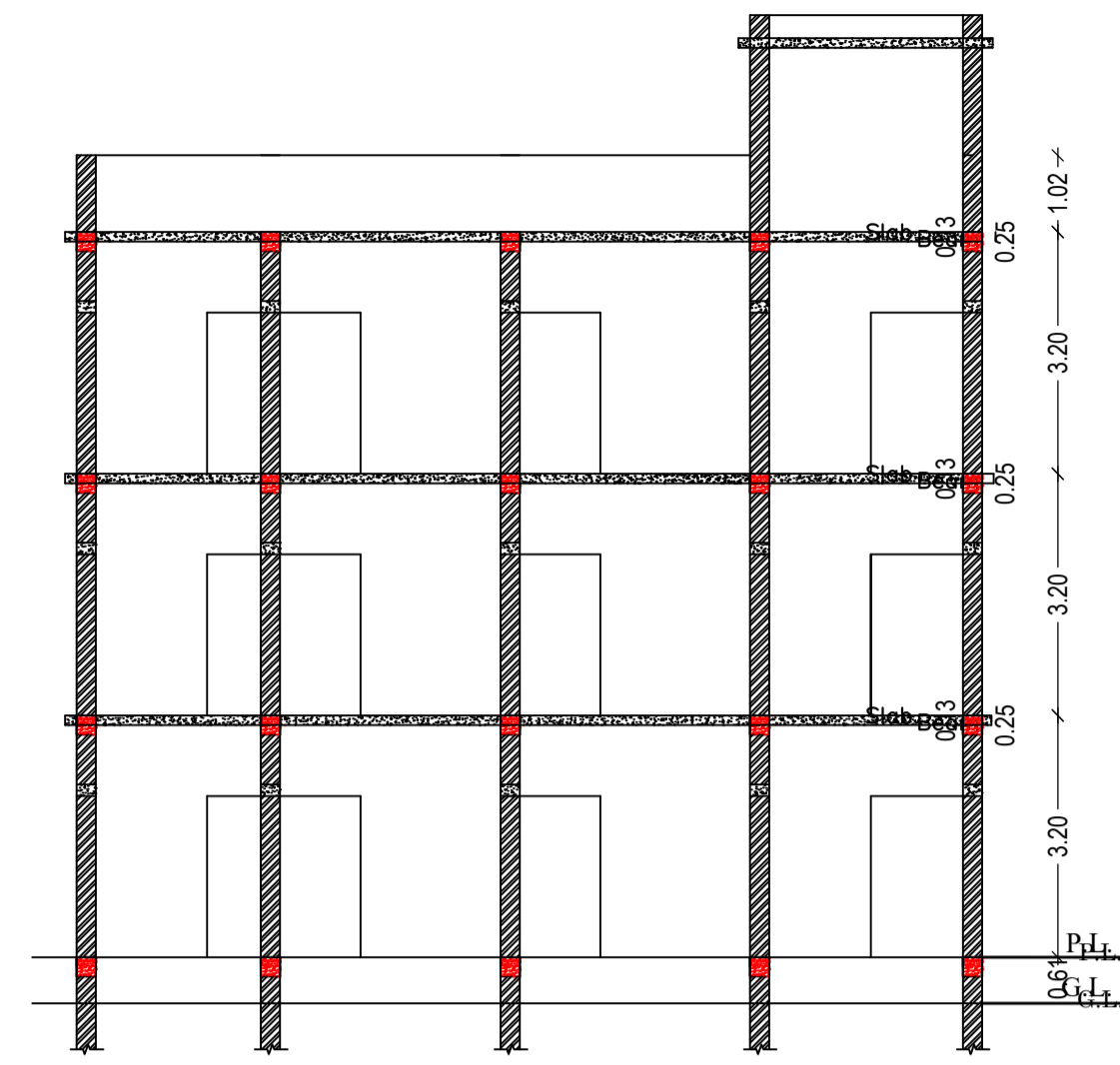

SECTION AT-Y-Y
SCALE 1:100

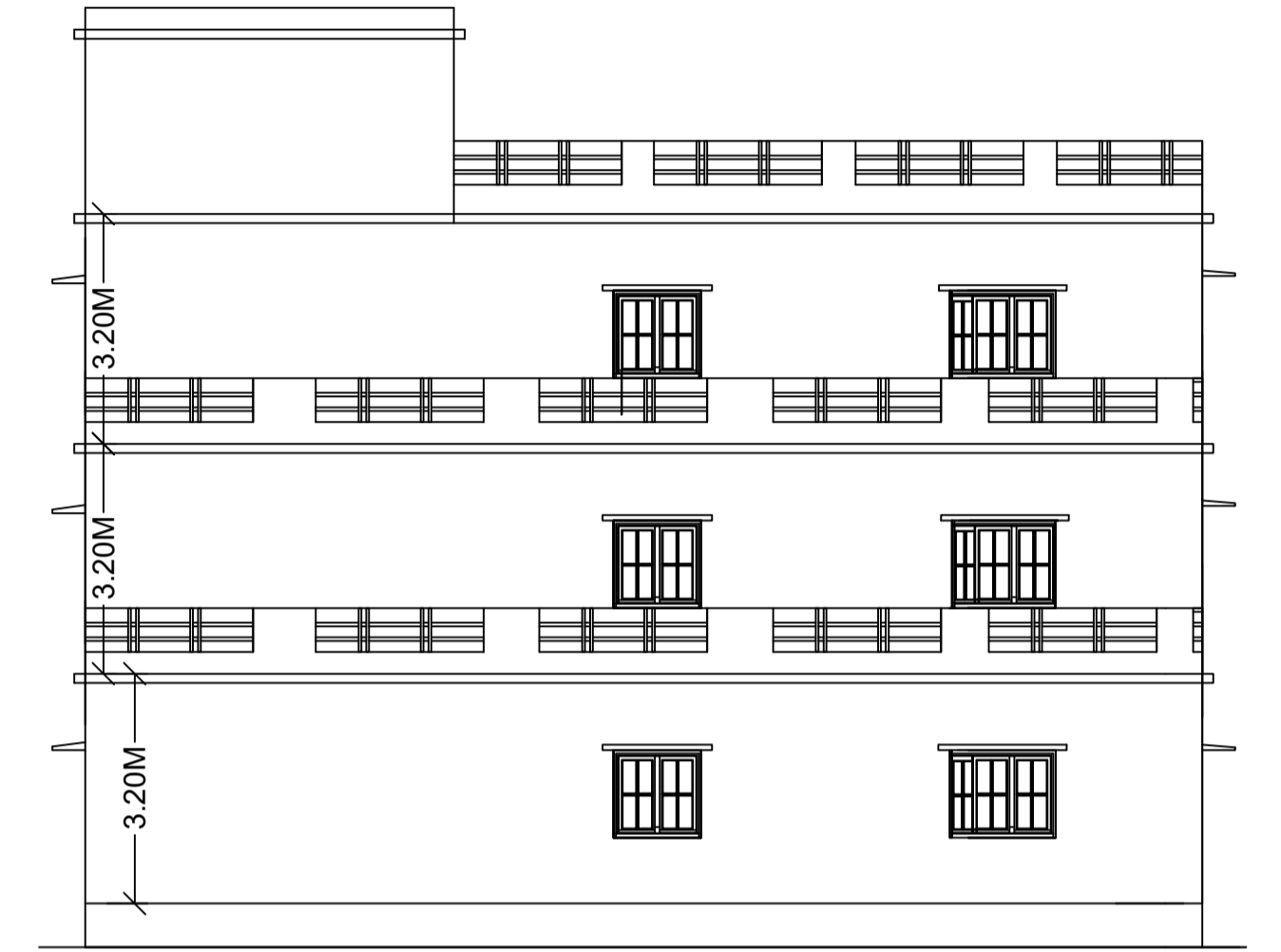

FRONT ELEVATION
SCALE 1:100

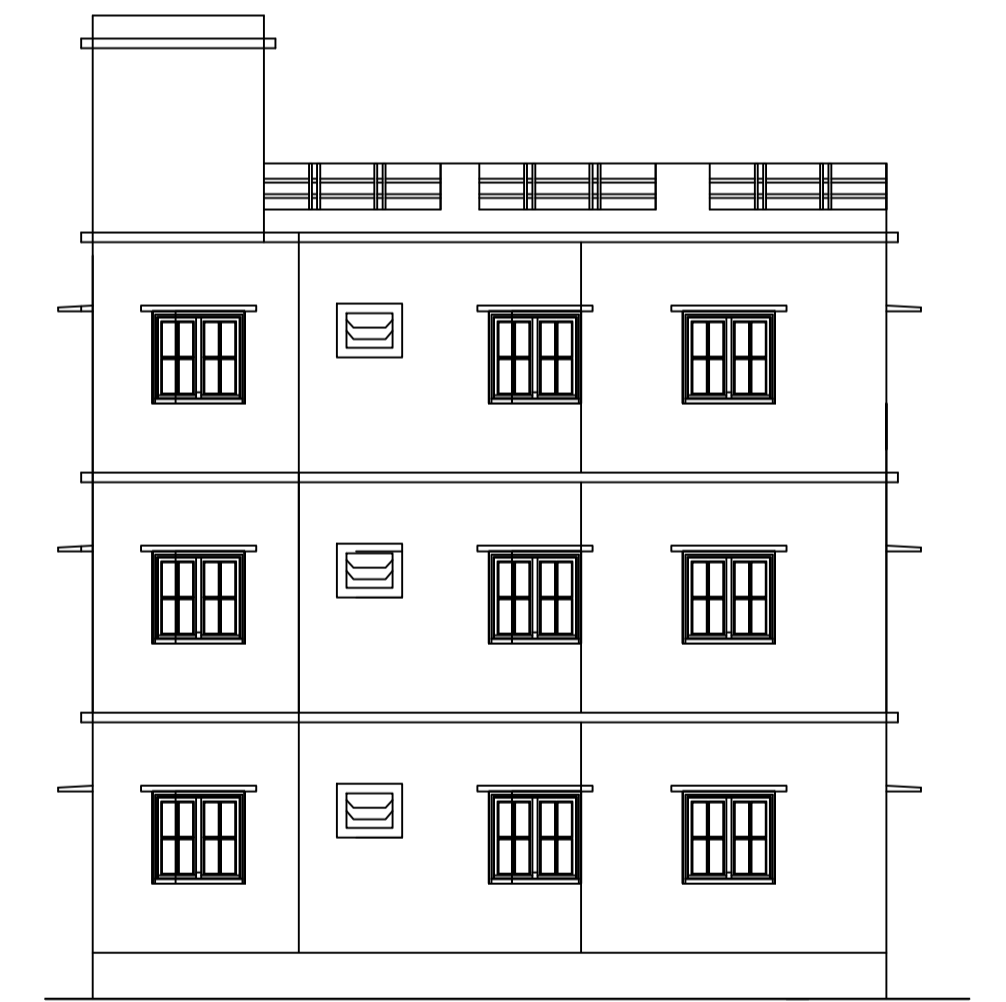

LEFT SIDE ELEVATION
SCALE 1:100

LTP NAME AND SIGNATURE	STRUCTURAL ENG'S NAME AND SIGNATURE	BUILDER NAME AND SIGNATURE	DIGITAL SIGNATURE
RAM RATAN SINGH SINPC/DFTMN/0003/2020			