

FAR & Tenement Details (Table 4c-1)

Building	No. of Same Bldg	Total Built Up Area (Sq.mt.)	Proposed FAR Area (Sq.mt.) Resi.	Total FAR Area (Sq.mt.)	Total Consumed Additional FAR Area (Sq.mt.)	Tnmt (No.)
A1 (RESIDENSE)	1	181.65	181.65	181.65	181.65	01
Grand Total	1	181.65	181.65	181.65	181.65	01

Proposal Basic Information

Proposal File No.	SINPC/BP/0247/W05/2021
Owner Name	MANORMA DEVI
Khata No	109
Plot No	5095
Village Name	Gotra
Use	Residential
SubUse	Bungalow/ Dwelling / Non Apartment

AREA STATEMENT SIMDEGA NAGAR PANCHAYAT	VERSION NO: 1.0.61	VERSION DATE: 16/10/2020
PROJECT DETAIL:	Region: JHARKHAND URBAN LOCAL BODIES	Plot Use: Residential
District: SIMDEGA	Authority: SIMDEGA NAGAR PANCHAYAT	Plot SubUse: Bungalow/ Dwelling / Non Apartment
Inward No: SINPC/BP/0247/W05/2021	Application Type: General Proposal	PlotNearbyReligiousStructure: NA
Project Type: Building Permission	Nature of Development: New	PlotSubPlot No: 5095
Location of Development Area: Old Area		North: -
		South: -
		East: -
		West: -
AREA DETAILS:		SQ.MT.
AREA OF PLOT (Minimum)	(A)	121.17
NET AREA OF PLOT(Gross Plot Area - Deduction from Gross Plot area)	(A-Deductions)	121.17
Deduction for Balance Plot Area(from Gross Plot Area)		
Common Plot		11.85
Total		11.85
BALANCE AREA OF PLOT(Net Plot Area - Recreational/Amenity space)	(A-Deductions)	109.32
PLOT AREA FOR COVERAGE(Net Plot Area)	(A-Deductions)	121.17
Plot Area for FAR (Net Plot Area + Road Widening Area)	(A-Deductions)	121.17
COVERAGE CHECK		
Permissible Coverage area ( 70.00 % )		84.82
Proposed Coverage Area ( 49.97 % )		60.55
Total Prop. Coverage Area ( 49.97 % )		60.55
Balance coverage area ( 20.03 % )		24.27
FAR CHECK		
Perm. FAR Area ( 1.50 )		181.76
Total Perm. FAR area		181.76
Residential FAR		181.66
Proposed FAR Area		181.66
Total Proposed FAR Area		181.66
Consumed FAR (Factor)		1.50
Balance FAR Area		0.10
BUILT UP AREA CHECK		
Total Proposed BuiltUp Area		181.65
ARCHITECT (Regd)		RAM RATAN SINGH
ENGINEER (Regd)		
SUPERVISOR (Regd)		
OWNER (Regd)		MANORMA DEVI
DEVELOPMENT AUTHORITY		LOCAL BODY

COLOR INDEX	
PLOT BOUNDARY	Black
ABUTTING ROAD	Green
PROPOSED CONSTRUCTION	Red
COMMON PLOT	Yellow
ROAD WIDENING AREA	Orange
EXISTING (To be retained)	Blue
EXISTING (To be demolished)	Light Blue

SITE PLAN

Buildingwise Floor FAR Details

Floor Name	Building Name A1 (RESIDENSE)		Total	
	Proposed Built Up Area (Sq.mt.)	Proposed FAR Area (Sq.mt.)	Total Proposed Built Up Area (Sq.mt.)	Total FAR Area (Sq.mt.)
Ground Floor	60.55	60.55	60.55	60.55
First Floor	60.55	60.55	60.55	60.55
Second Floor	60.55	60.55	60.55	60.55
Terrace Floor	0.00	0.00	0.00	0.00
Total	181.65	181.65	181.65	181.65

Building USE/SUBUSE Details

Building Name	Building Use	Building SubUse	Building Structure
A1 (RESIDENSE)	Residential	Bungalow/ Dwelling / Non Apartment	Non-Highrise

LTP NAME AND SIGNATURE	STRUCTURAL ENG'S NAME AND SIGNATURE	BUILDER NAME AND SIGNATURE	DIGITAL SIGNATURE
RAM RATAN SINGH SINPC/DFTMN/0003/2020			

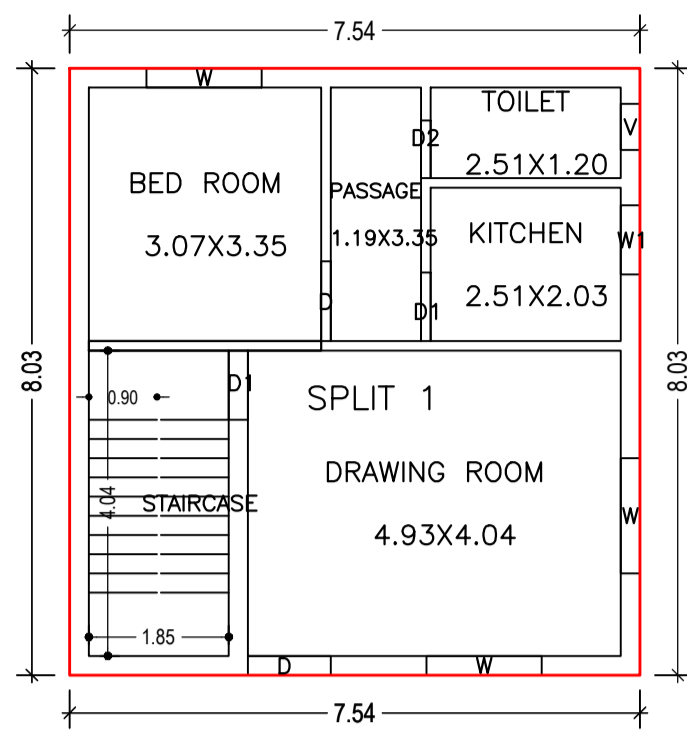

GROUND FLOOR PLAN (Proposed) (SCALE 1:100)

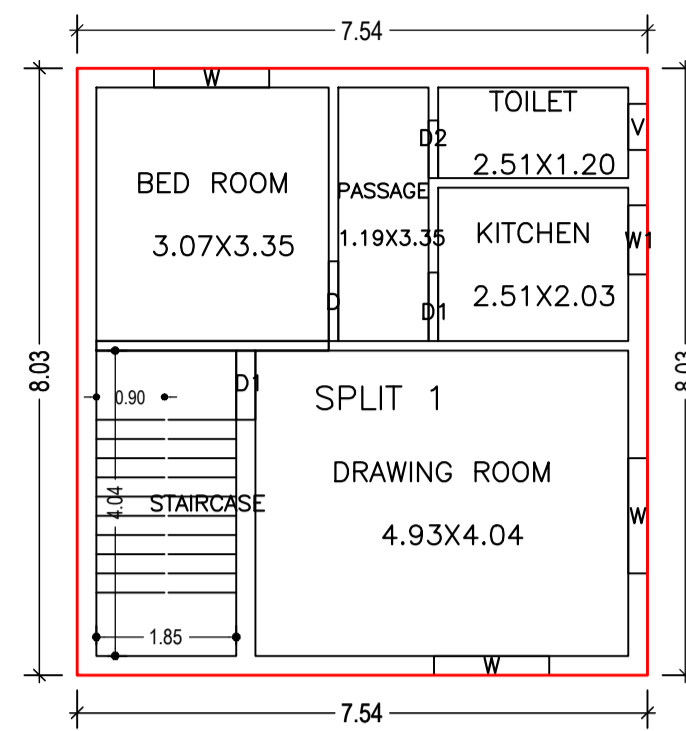

SECOND FLOOR PLAN (Proposed) (SCALE 1:100)

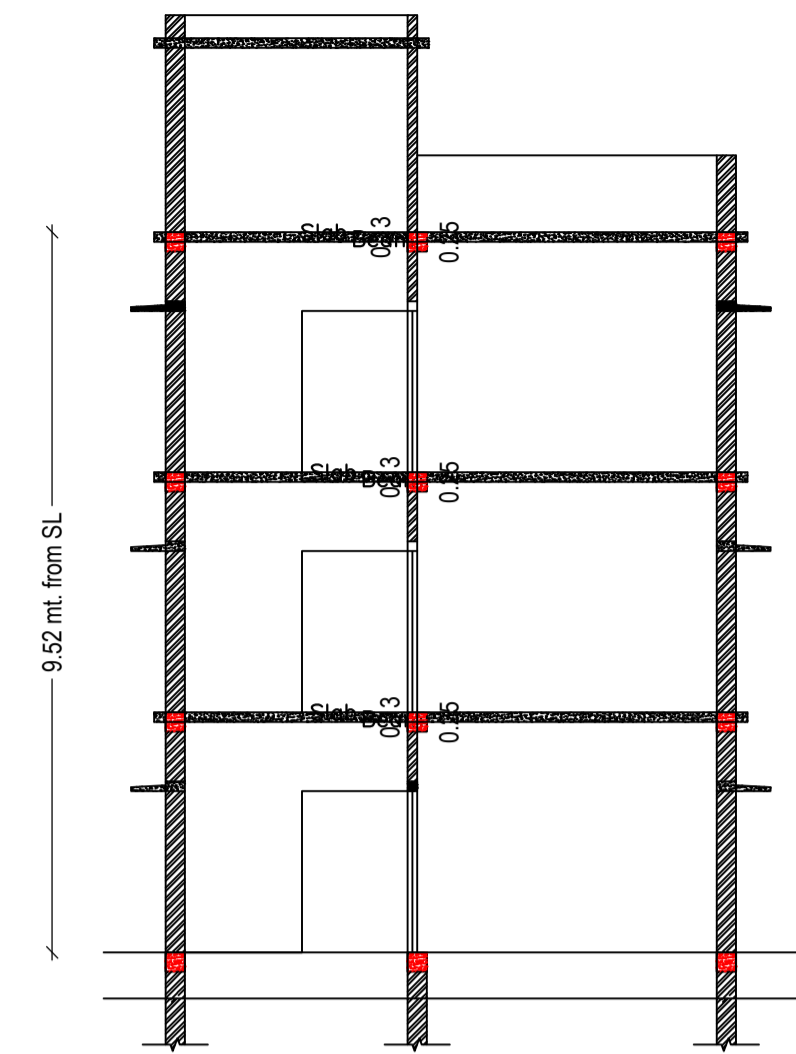

SECTION ON SCALE 1:100

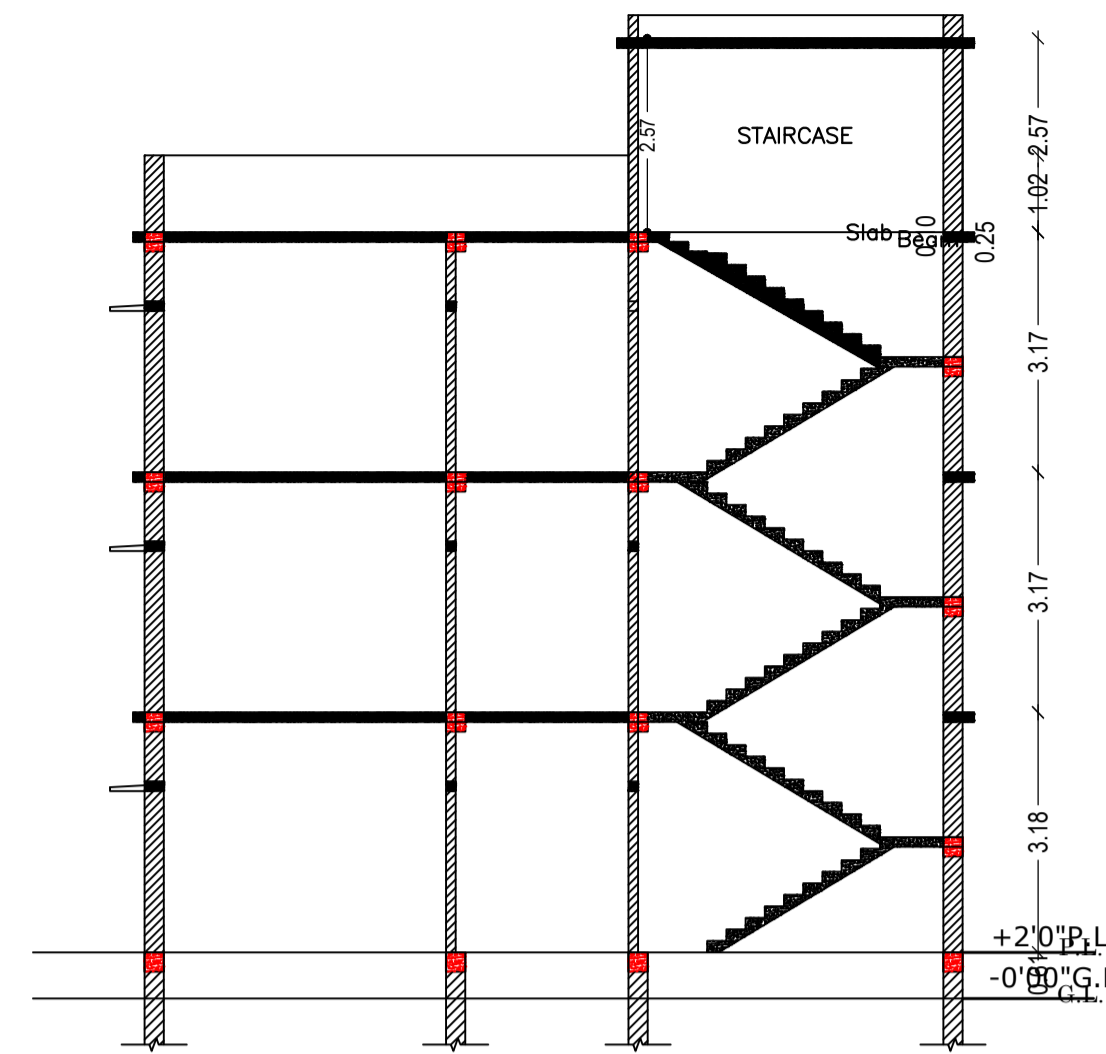

SECTION ON SCALE 1:100

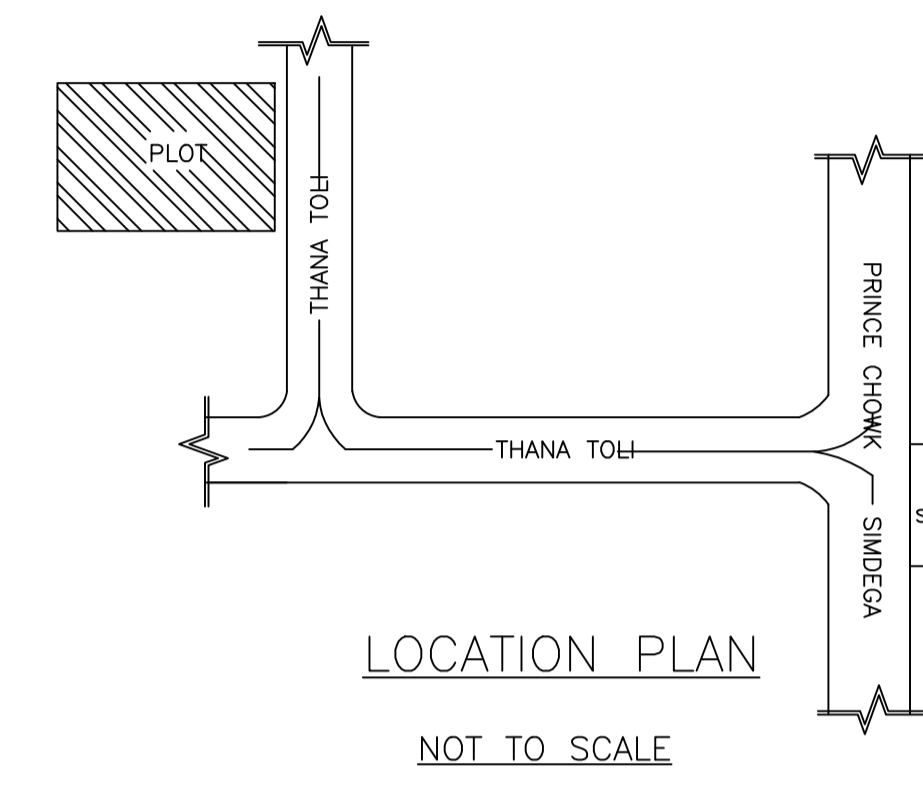

LOCATION PLAN NOT TO SCALE

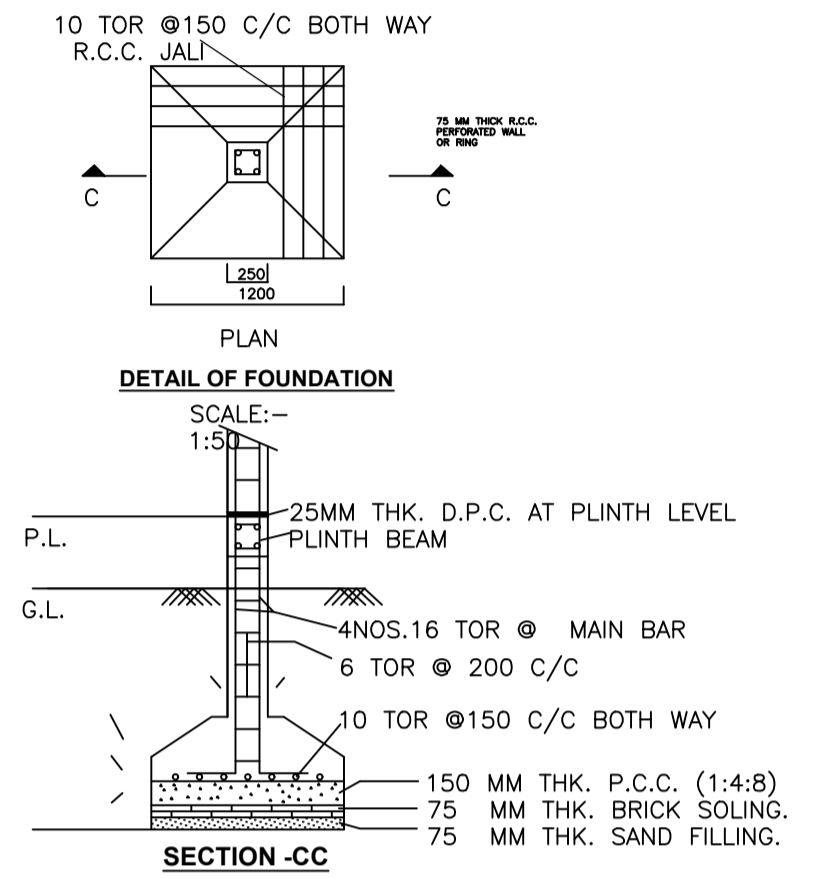

DETAIL OF FOUNDATION SCALE: 1:50

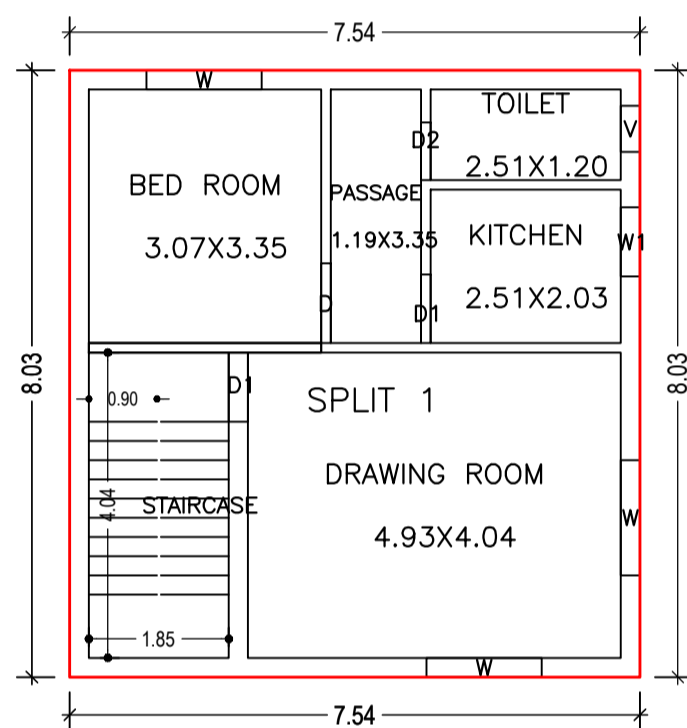

FIRST FLOOR PLAN (Proposed) (SCALE 1:100)

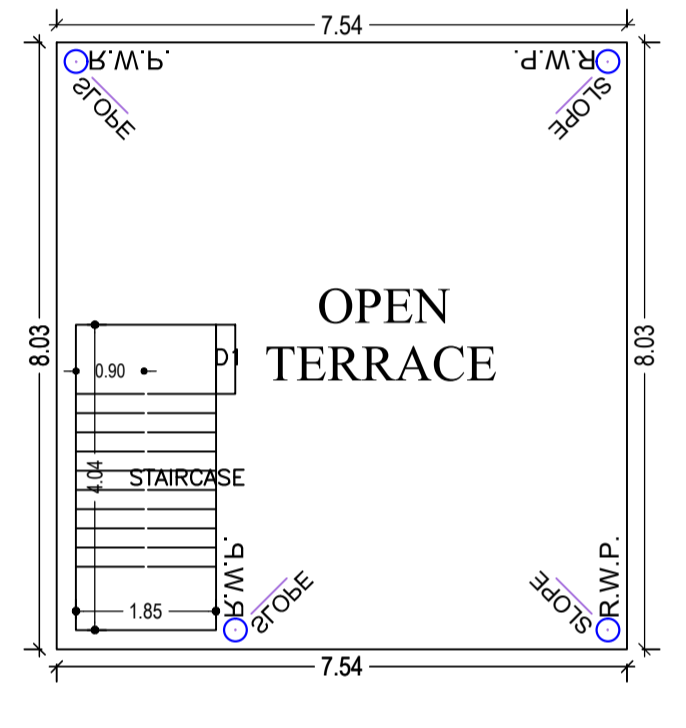

TERRACE FLOOR PLAN (SCALE 1:100)

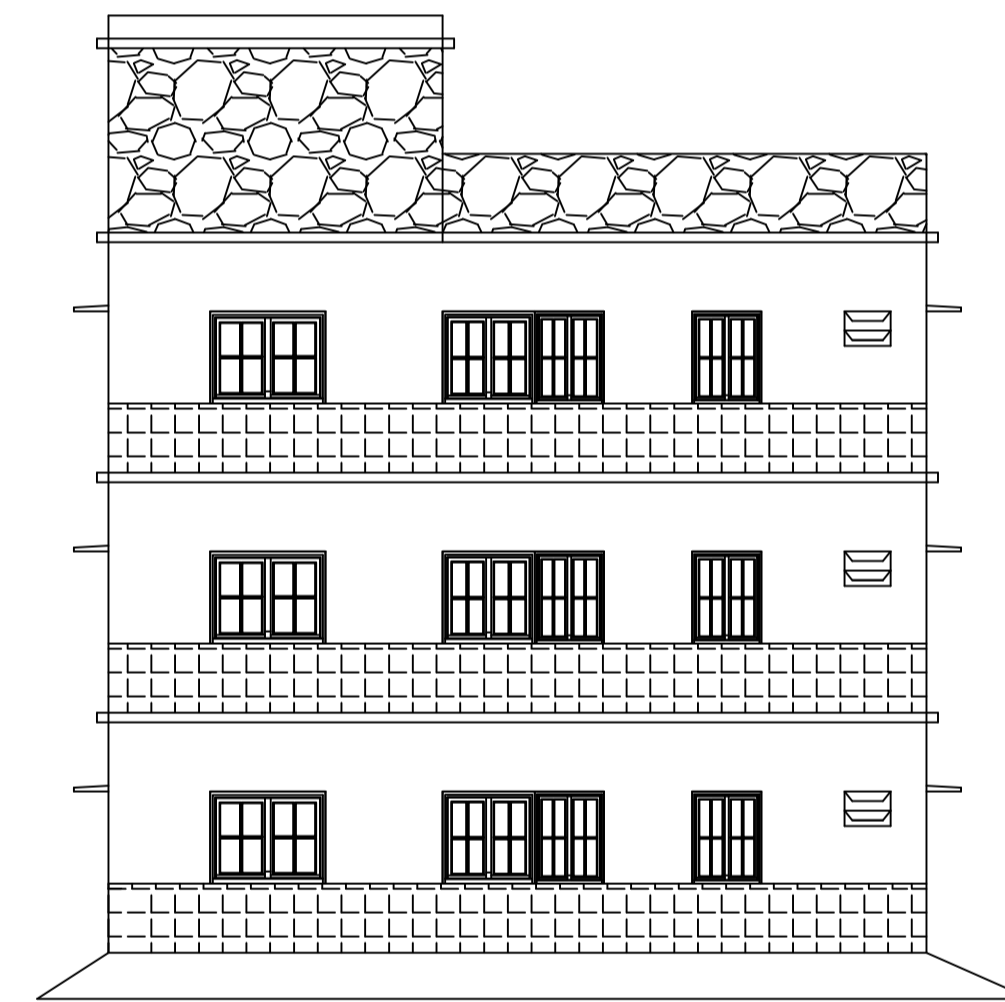

RIGHT SIDE ELEVATION SCALE 1:100

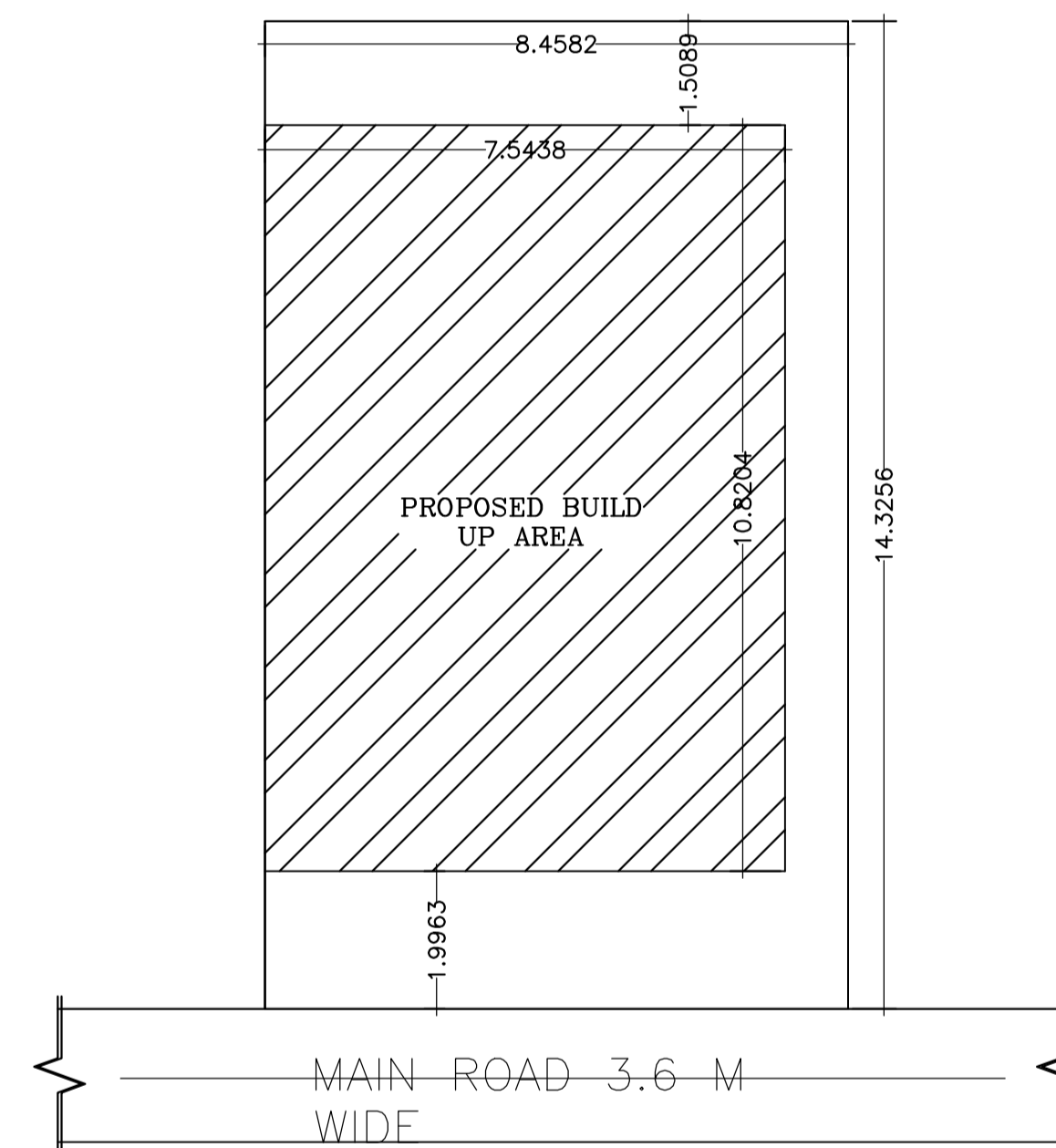

KEY PLAN SCALE 1:100

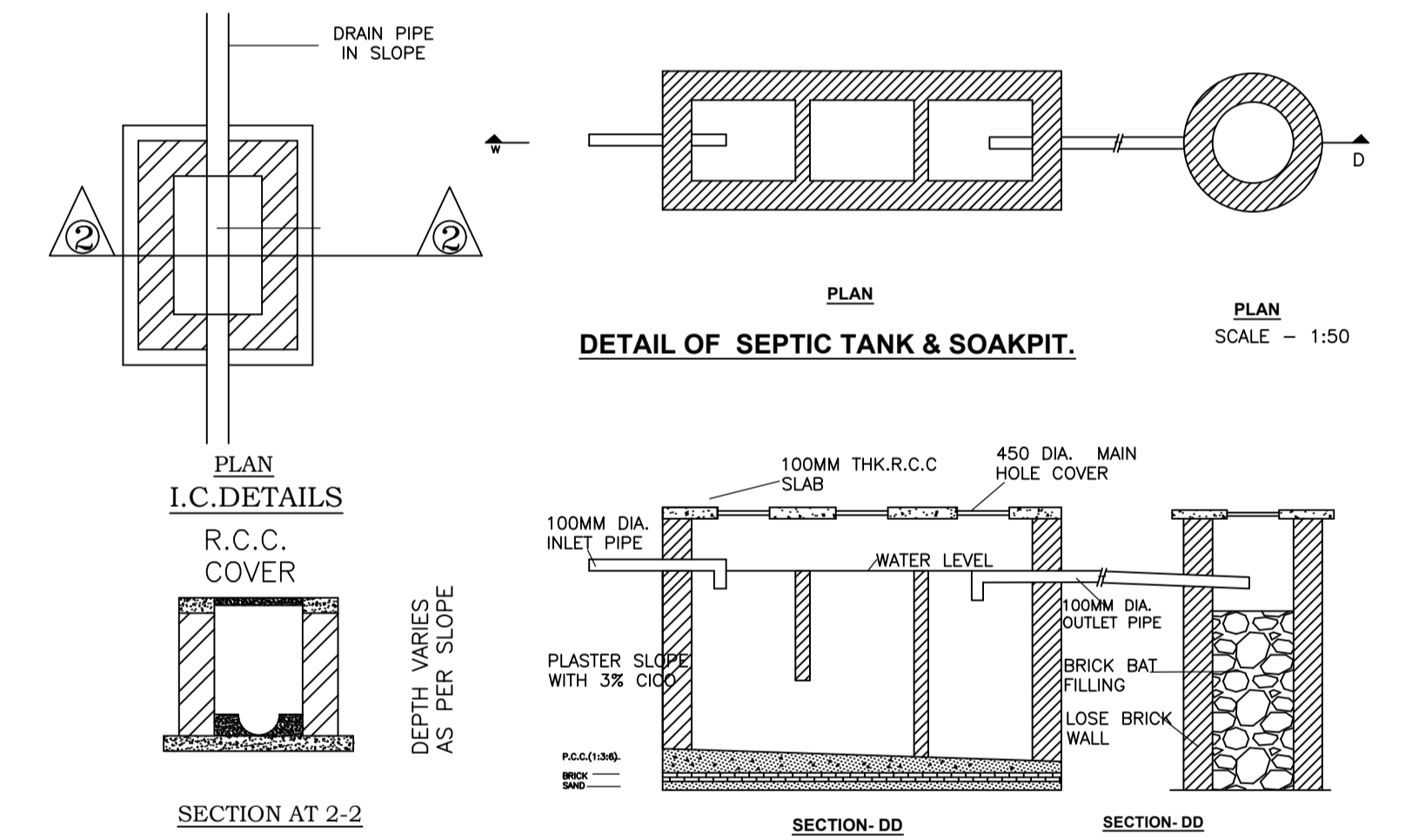

DETAIL OF SEPTIC TANK & SOAKPIT. SCALE - 1:50

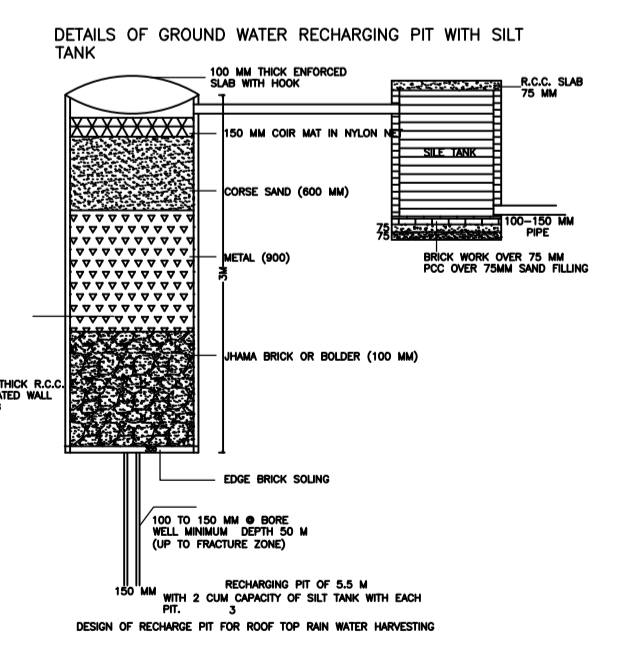
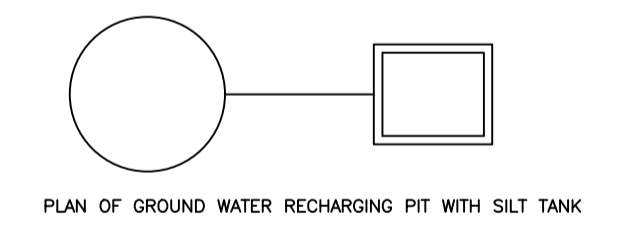

Building :A1 (RESIDENSE)

Floor Name	Total Built Up Area (Sq.mt.)	Proposed FAR Area (Sq.mt.)	Total FAR Area (Sq.mt.)	Total Consumed Additional FAR Area (Sq.mt.)	Tnmt (No.)
Ground Floor	60.55	60.55	60.55	60.55	01
First Floor	60.55	60.55	60.55	60.55	00
Second Floor	60.55	60.55	60.55	60.55	00
Terrace Floor	0.00	0.00	0.00	0.00	00
Total :	181.65	181.65	181.65	181.65	01
Total Number of Same Buildings	1				
Total :	181.65	181.65	181.65	181.65	01

SCHEDULE OF DOOR:

BUILDING NAME	NAME	LENGTH	HEIGHT	NOS
A1 (RESIDENSE)	D2	0.76	2.10	03
A1 (RESIDENSE)	D1	0.90	2.10	03
A1 (RESIDENSE)	D1	0.91	2.10	03
A1 (RESIDENSE)	D	1.06	2.10	03
A1 (RESIDENSE)	D	1.10	2.10	01

SCHEDULE OF WINDOW/VENTILATION:

BUILDING NAME	NAME	LENGTH	HEIGHT	NOS
A1 (RESIDENSE)	V	0.61	1.20	03
A1 (RESIDENSE)	W1	0.91	1.20	03
A1 (RESIDENSE)	W	1.52	1.20	09

UnitBUA Table for Building :A1 (RESIDENSE)

FLOOR	Name	UnitBUA Type	UnitBUA Area	Carpet Area	No. of Rooms	No. of Tenement
GROUND FLOOR PLAN	SPLIT 1	FLAT	133.21	132.04	5	1
FIRST FLOOR PLAN	SPLIT 1	FLAT	0.00	0.00	5	0
SECOND FLOOR PLAN	SPLIT 1	FLAT	0.00	0.00	5	0
Total:	-	-	133.21	132.04	15	1

LTP NAME AND SIGNATURE	STRUCTURAL ENG'S NAME AND SIGNATURE	BUILDER NAME AND SIGNATURE	DIGITAL SIGNATURE
RAM RATAN SINGH SINPC/DFTMN/0003/2020			

Proposal Basic Information	
Proposal File No.	SINPC/BP/0247/W05/2021
Owner Name	MANORMA DEVI
Khata No	109
Plot No	5095
Village Name	Gotra
Use	Residential
SubUse	Bungalow/ Dwelling / Non Apartment

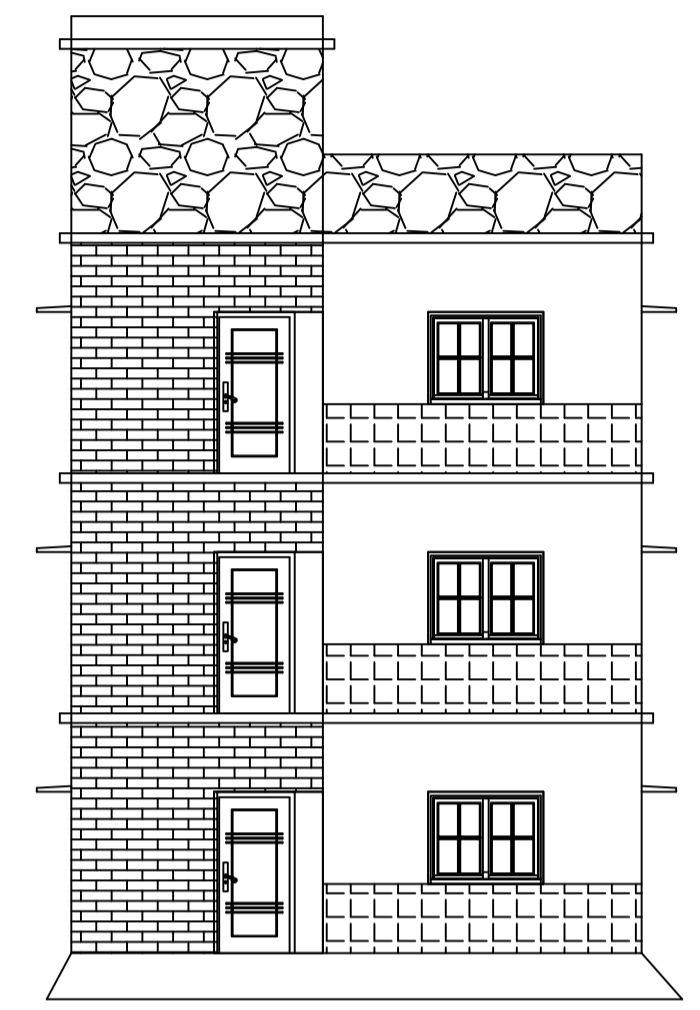

FRONT ELEVATION  
SCALE 1:100

LTP NAME AND SIGNATURE	STRUCTURAL ENG'S NAME AND SIGNATURE	BUILDER NAME AND SIGNATURE	DIGITAL SIGNATURE
RAM RATAN SINGH SINPC/DFTMN/0003/2020			