

Proposal Basic Information

Proposal File No.	SINPC/BP/0197/W03/2021
Owner Name	SALIM KANDULNA
Khata No	56
Plot No	1790
Village Name	Saldega
Use	Residential
SubUse	Bungalow/ Dwelling / Non Apartment

AREA STATEMENT SIMDEGA NAGAR PANCHAYAT	VERSION NO : 1.0.53	VERSION DATE: 16/10/2020
PROJECT DETAIL	Plot Use: Residential	
Region: JHARKHAND URBAN LOCAL BODIES	Plot SubUse: Bungalow/ Dwelling / Non Apartment	
District: SIMDEGA	PlotNearbyReligiousStructure: NA	
Authority: SIMDEGA NAGAR PANCHAYAT	PlotSubPlot No: 1790	
Inward No: SINPC/BP/0197/W03/2021	North: -	
Application Type: General Proposal	South: -	
Project Type: Building Permission	East: -	
Nature of Development: New	West: -	
Location of Development Area: Old Area		
AREA DETAILS:		SQ.MT.
AREA OF PLOT (Minimum)	(A)	1115.74
NET AREA OF PLOT(Gross Plot Area - Deduction from Gross Plot area)	(A-Deductions)	1115.74
Deduction for Balance Plot Area(from Gross Plot Area)		
Common Plot		59.23
Total		59.23
BALANCE AREA OF PLOT(Net Plot Area - Recreational/Amenity space)	(A-Deductions)	1056.51
PLOT AREA FOR COVERAGE(Net Plot Area)	(A-Deductions)	1115.74
Plot Area for FAR (Net Plot Area + RoadWidening Area)	(A-Deductions)	1115.74
COVERAGE CHECK		
Permissible Coverage area (50.00 %)		557.87
Proposed Coverage Area (10.94 %)		122.10
Total Prop. Coverage Area (10.94 %)		122.10
Balance coverage area (39.06 %)		435.77
FAR CHECK		
Perm. FAR Area (1.50)		1673.61
Total Perm. FAR area		1673.61
Residential FAR		122.10
Proposed FAR Area		122.10
Total Proposed FAR Area		122.10
Consumed FAR (Factor)		0.11
Balance FAR Area		1551.51
BUILT UP AREA CHECK		
Total Proposed BuiltUp Area		122.10
ARCHITECT (Regd)	RAM RATAN SINGH	
ENGINEER (Regd)		
SUPERVISOR (Regd)		
OWNER (Regd)	SALIM KANDULNA	
DEVELOPMENT AUTHORITY	LOCAL BODY	

COLOR INDEX

PLOT BOUNDARY	Black
ABUTTING ROAD	Green
PROPOSED CONSTRUCTION	Red
COMMON PLOT	Yellow
ROAD WIDENING AREA	Blue
EXISTING (To be retained)	Light Blue
EXISTING (To be demolished)	Dark Blue

SITE PLAN

Buildingwise Floor FAR Details

Floor Name	Building Name A1 (RESIDENSE)		Total	
	Proposed Built Up Area (Sq.mt.)	Proposed FAR Area (Sq.mt.)	Total Proposed Built Up Area (Sq.mt.)	Total FAR Area (Sq.mt.)
Ground Floor	122.10	122.10	122.10	122.10
Terrace Floor	0.00	0.00	0.00	0.00
Total	122.10	122.10	122.10	122.10

FAR & Tenement Details (Table 4c-1)

Building	No. of Same Bldg	Total Built Up Area (Sq.mt.)	Proposed FAR Area (Sq.mt.) Rest.	Total FAR Area (Sq.mt.)	Total Consumed Additional FAR Area (Sq.mt.)	Trmt (No.)
A1 (RESIDENSE)	1	122.10	122.10	122.10	122.10	01
Grand Total :	1	122.10	122.10	122.10	122.10	01

Building USE/SUBUSE Details

Building Name	Building Use	Building SubUse	Building Structure
A1 (RESIDENSE)	Residential	Residential Bldg/Apartment	Non-Highrise

LTP NAME AND SIGNATURE	STRUCTURAL ENG'S NAME AND SIGNATURE	BUILDER NAME AND SIGNATURE	DIGITAL SIGNATURE
RAM RATAN SINGH SINPC/DFTMN/0003/2020			

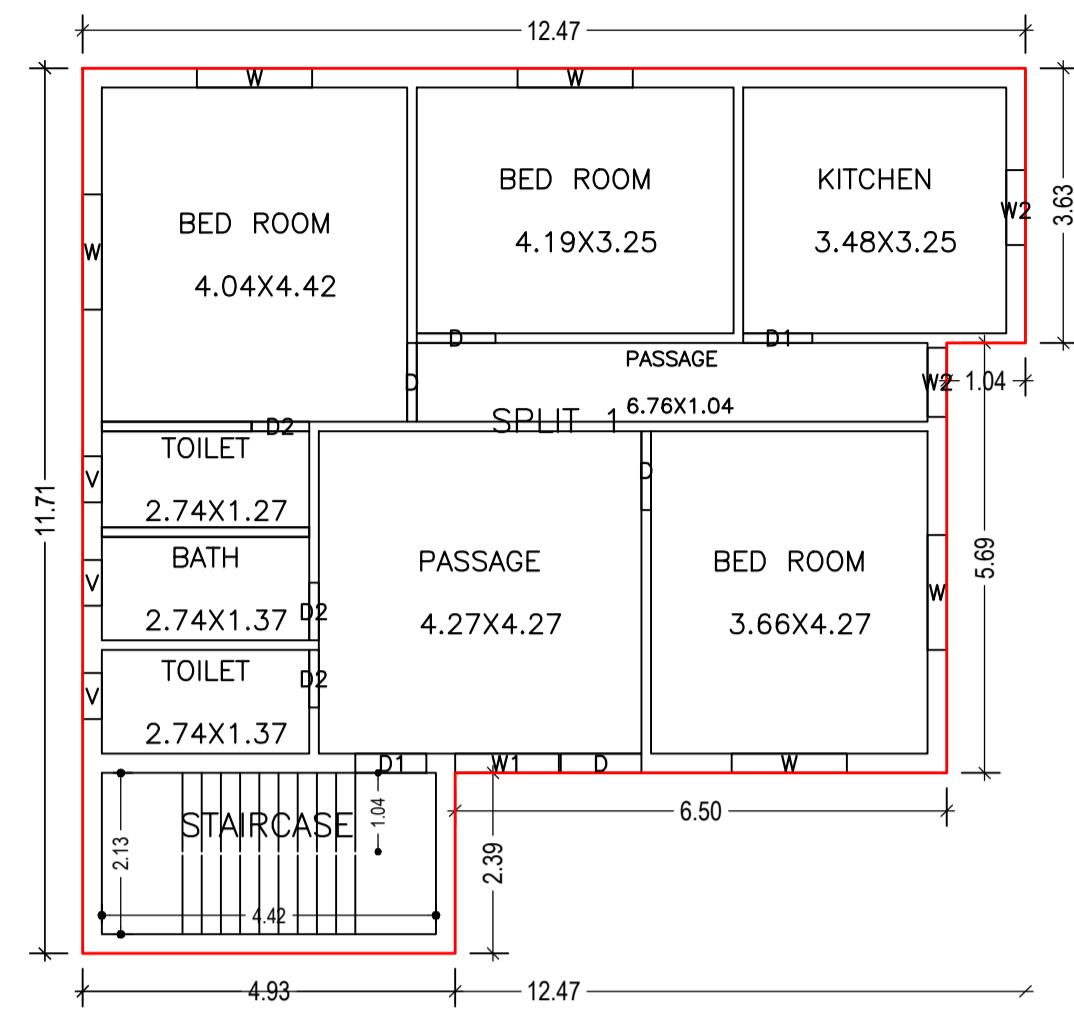

GROUND FLOOR PLAN (Proposed) (SCALE 1:100)

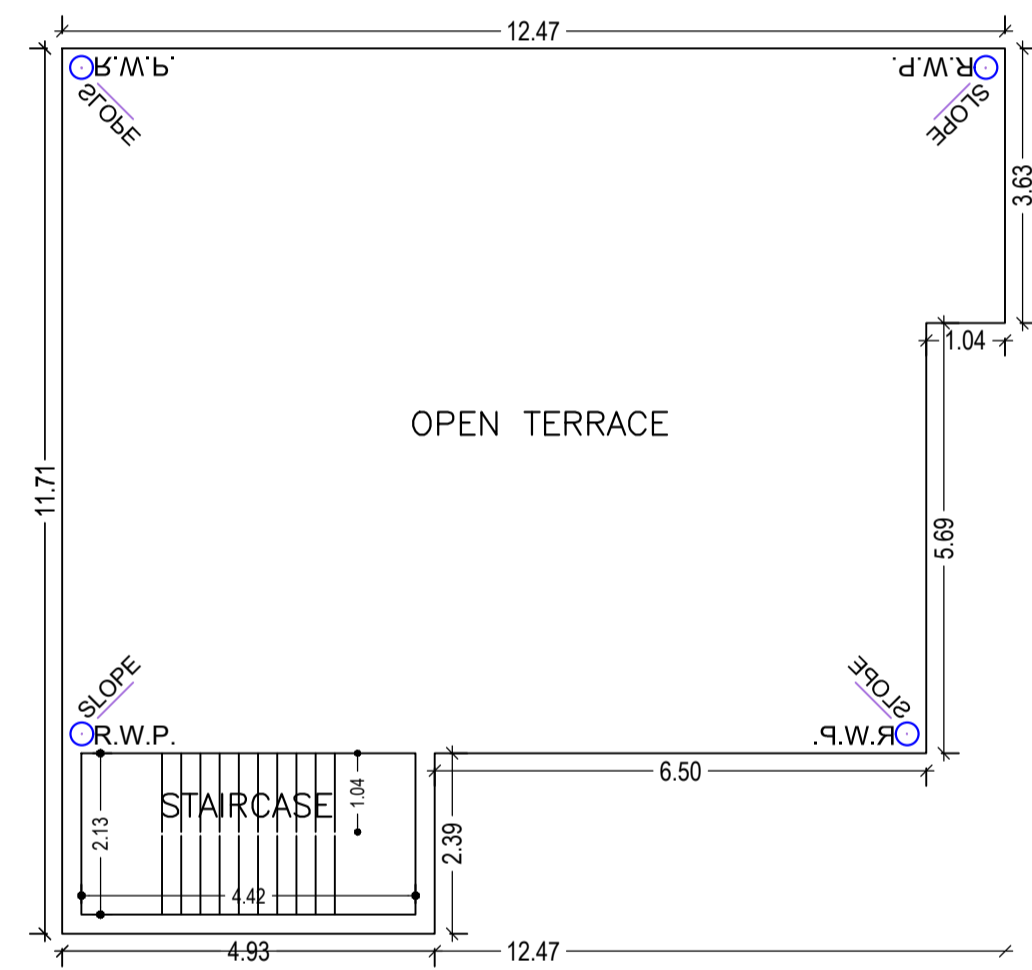

TERRACE FLOOR PLAN (SCALE 1:100)

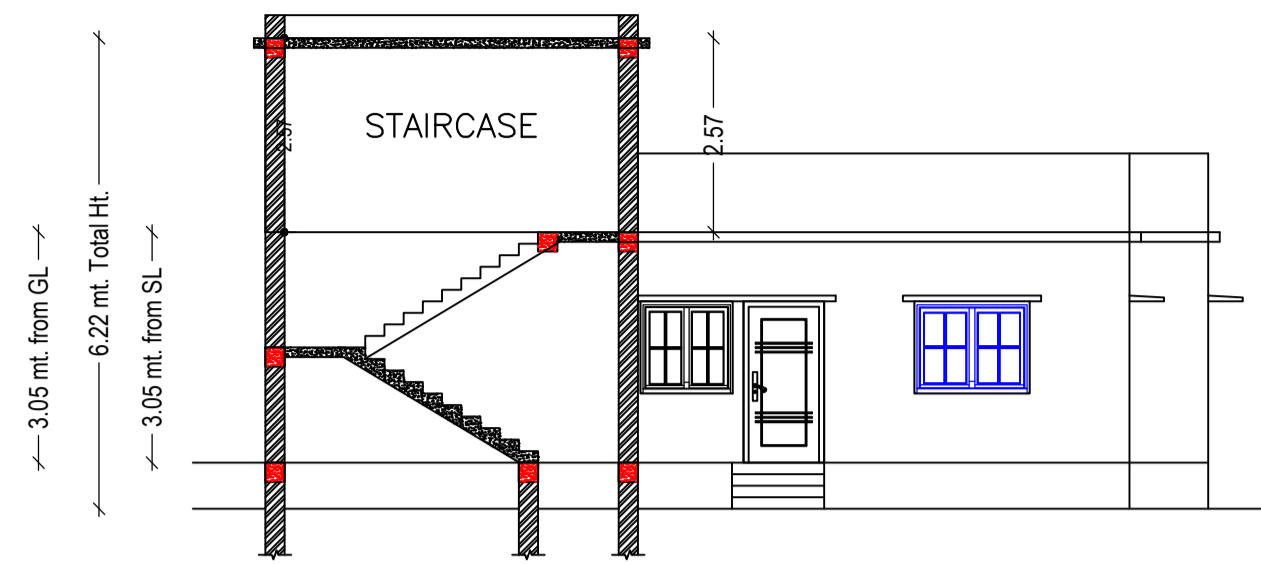

SECTION AT-X-X SCALE 1:100

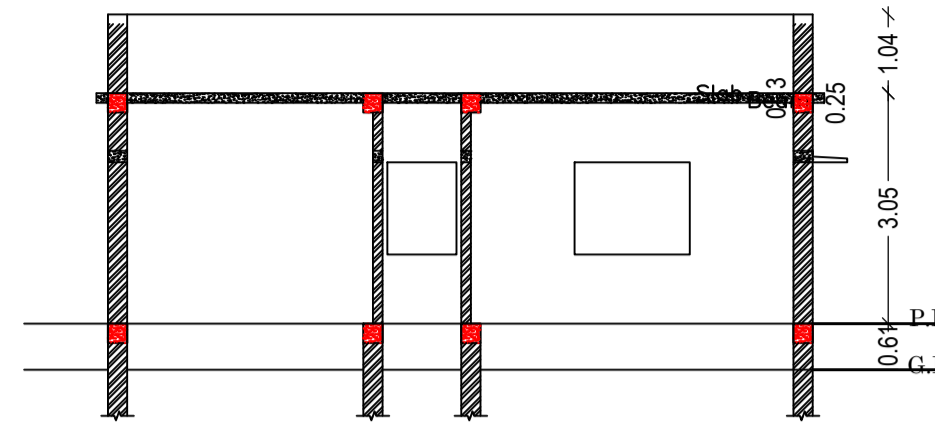

SECTION AT-Y-Y SCALE 1:100



FRONT ELEVATION SCALE 1:100

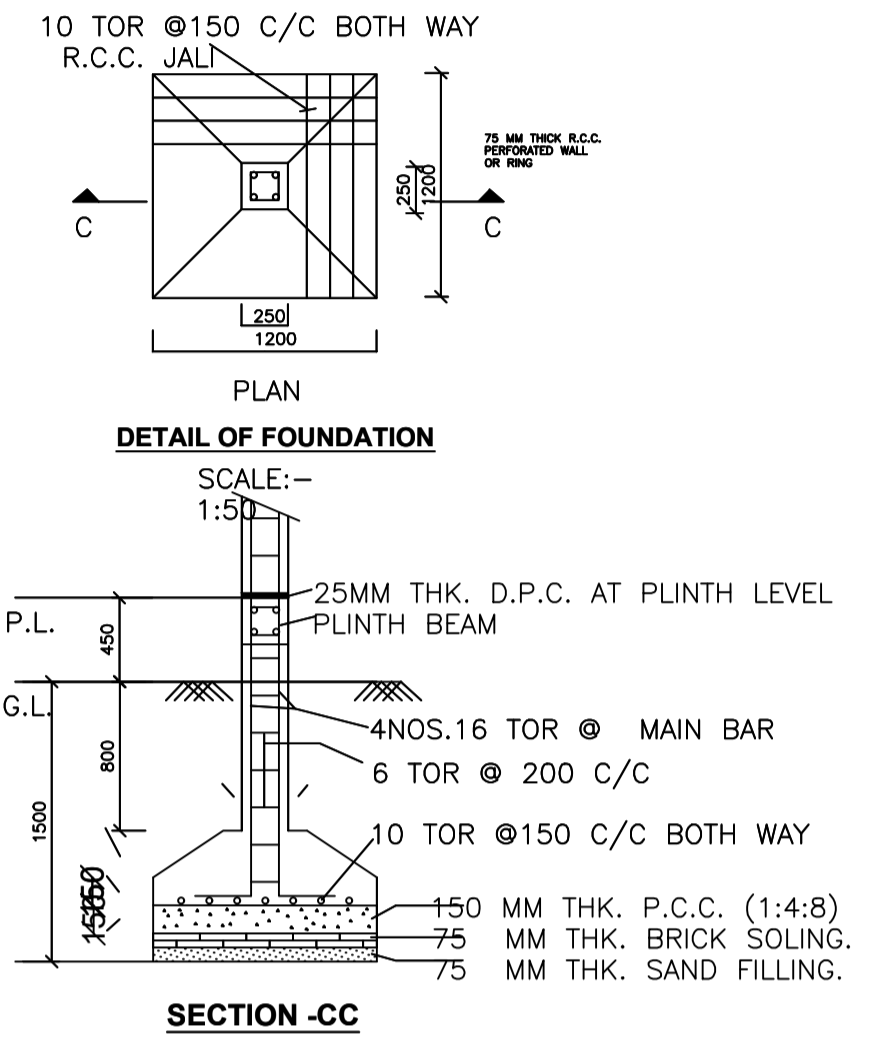

SECTION -CC

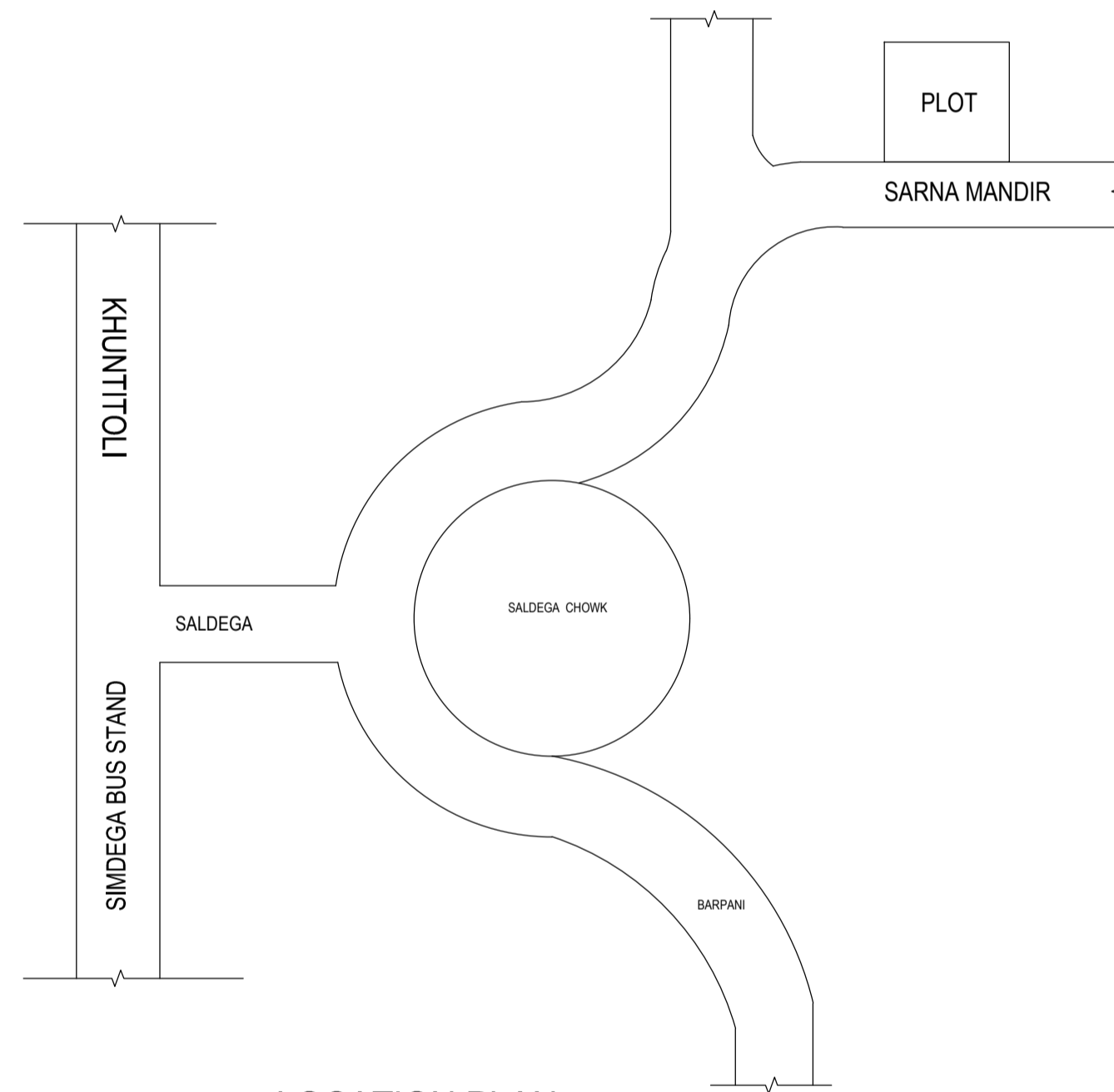

LOCATION PLAN NOT TO SCALE

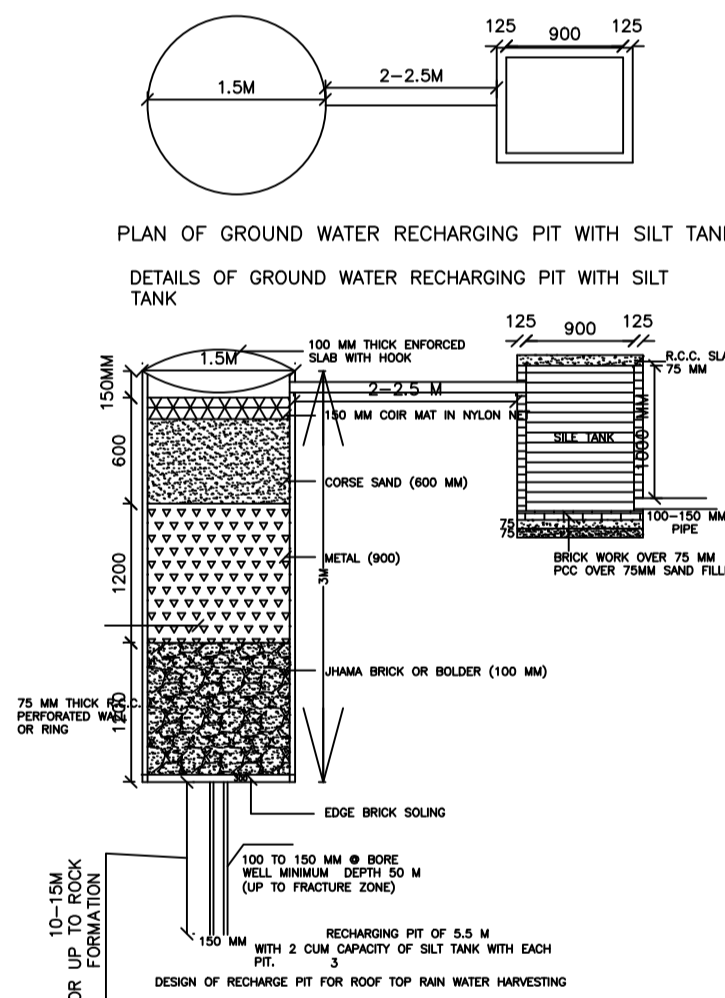

PLAN OF GROUND WATER RECHARGING PIT WITH SILT TANK
DETAILS OF GROUND WATER RECHARGING PIT WITH SILT TANK

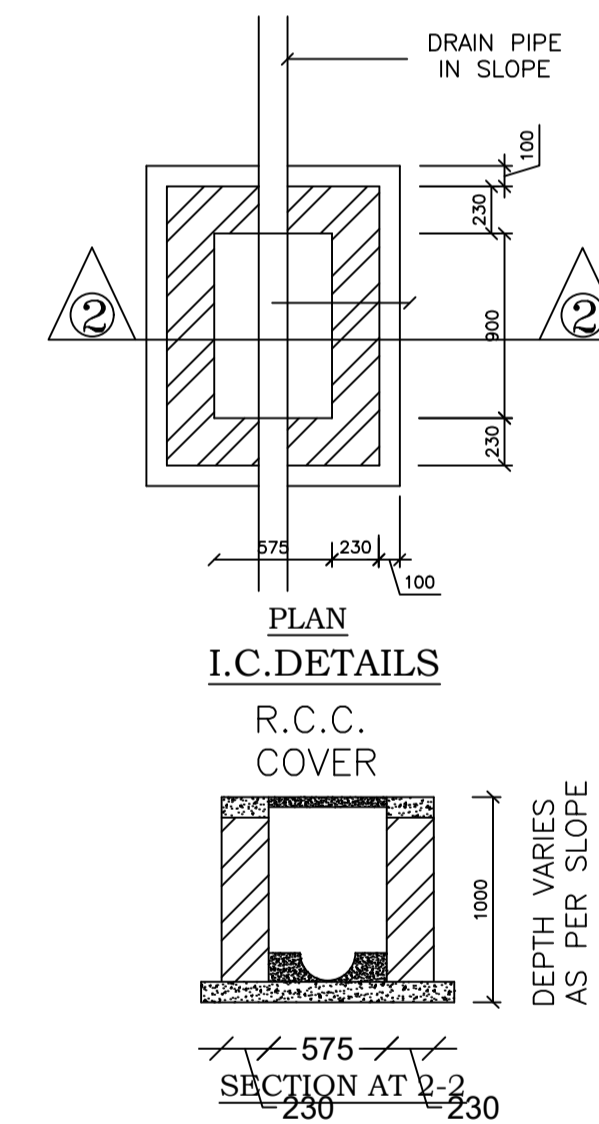

PLAN I.C.DETAILS R.C.C. COVER

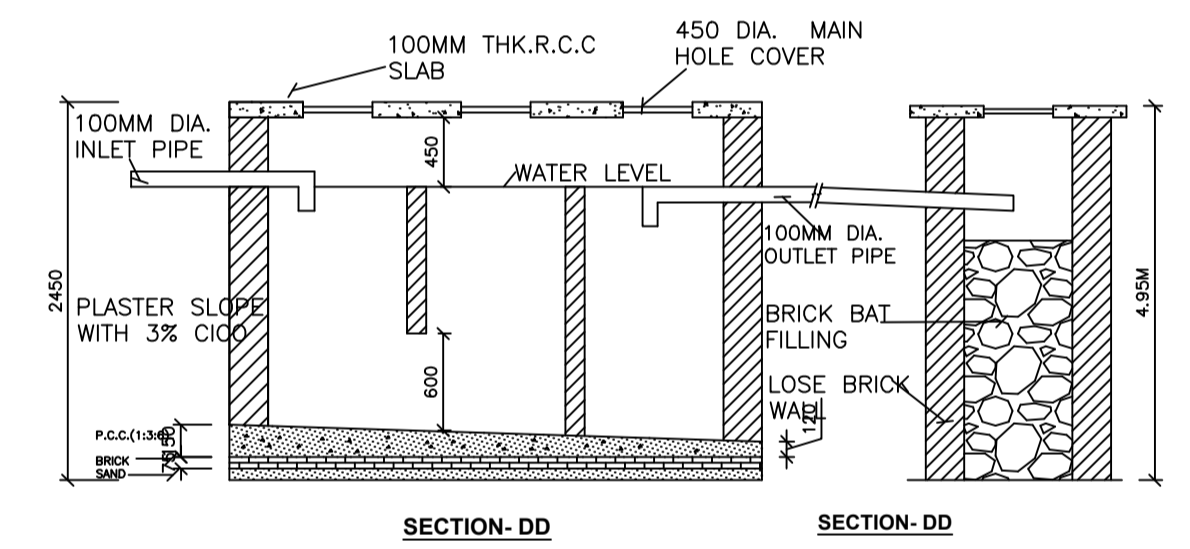

SECTION -DD

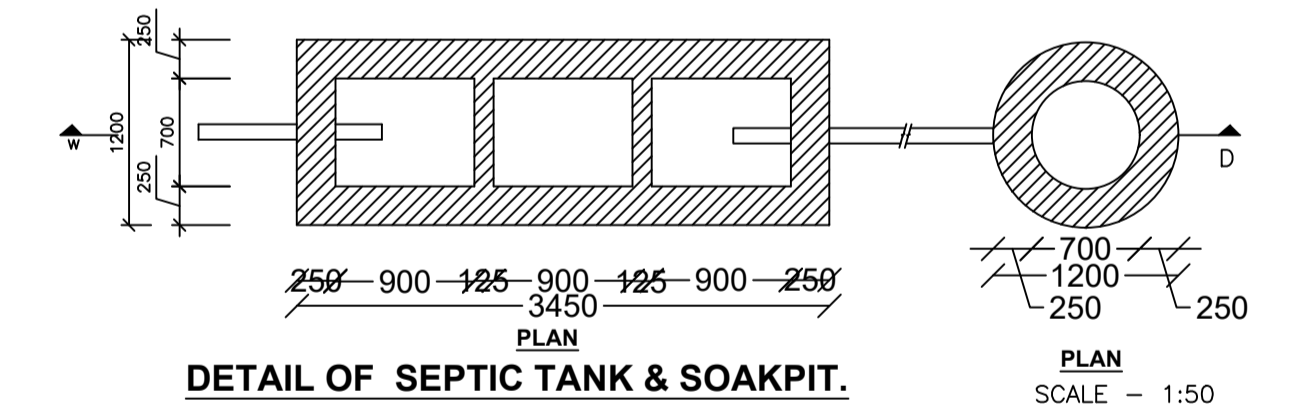

DETAIL OF SEPTIC TANK & SOAKPIT.

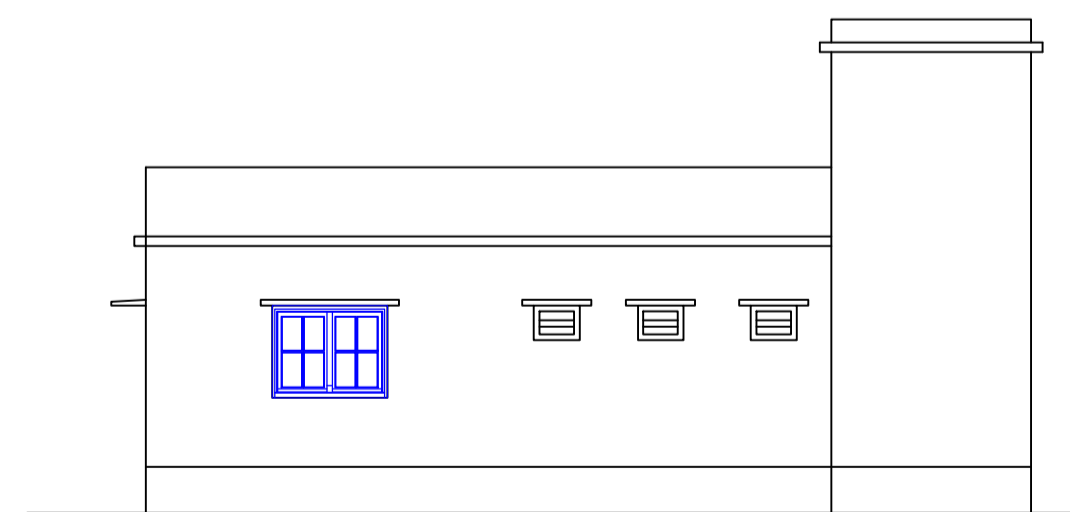

LEFT SIDE ELEVATION SCALE 1:100

SCHEDULE OF DOOR:

BUILDING NAME	NAME	LENGTH	HEIGHT	NOS
A1 (RESIDENSE)	D2	0.76	2.10	03
A1 (RESIDENSE)	D1	0.91	2.10	01
A1 (RESIDENSE)	D1	0.94	2.10	01
A1 (RESIDENSE)	D	1.04	2.10	03
A1 (RESIDENSE)	D	1.07	2.10	01

SCHEDULE OF WINDOW/VENTILATION:

BUILDING NAME	NAME	LENGTH	HEIGHT	NOS
A1 (RESIDENSE)	V	0.61	1.20	03
A1 (RESIDENSE)	W2	0.91	1.20	01
A1 (RESIDENSE)	W2	0.99	1.20	01
A1 (RESIDENSE)	W1	1.37	1.20	01
A1 (RESIDENSE)	W	1.52	1.20	05

UnitBUA Table for Building :A1 (RESIDENSE)

FLOOR	Name	UnitBUA Type	UnitBUA Area	Carpet Area	No. of Rooms	No. of Tenement
GROUND FLOOR PLAN	SPLIT 1	FLAT	99.65	99.05	9	1
Total:	-	-	99.65	99.05	9	1

Building :A1 (RESIDENSE)

Floor Name	Total Built Up Area (Sq.mt.)	Proposed FAR Area (Sq.mt.)	Total FAR Area (Sq.mt.)	Total Consumed Additional FAR Area (Sq.mt.)	Tnmt (No.)
Ground Floor	122.10	122.10	122.10	122.10	01
Terrace Floor	0.00	0.00	0.00	0.00	00
Total:	122.10	122.10	122.10	122.10	01
Total Number of Same Buildings	1				
Total:	122.10	122.10	122.10	122.10	01

LTP NAME AND SIGNATURE	STRUCTURAL ENG'S NAME AND SIGNATURE	BUILDER NAME AND SIGNATURE	DIGITAL SIGNATURE
RAM RATAN SINGH SINPC/DFTMN/0003/2020			

Proposal Basic Information	
Proposal File No.	SINPC/BP/0197/W03/2021
Owner Name	SALIM KANDULNA
Khata No	56
Plot No	1790
Village Name	Saldega
Use	Residential
SubUse	Bungalow/ Dwelling / Non Apartment

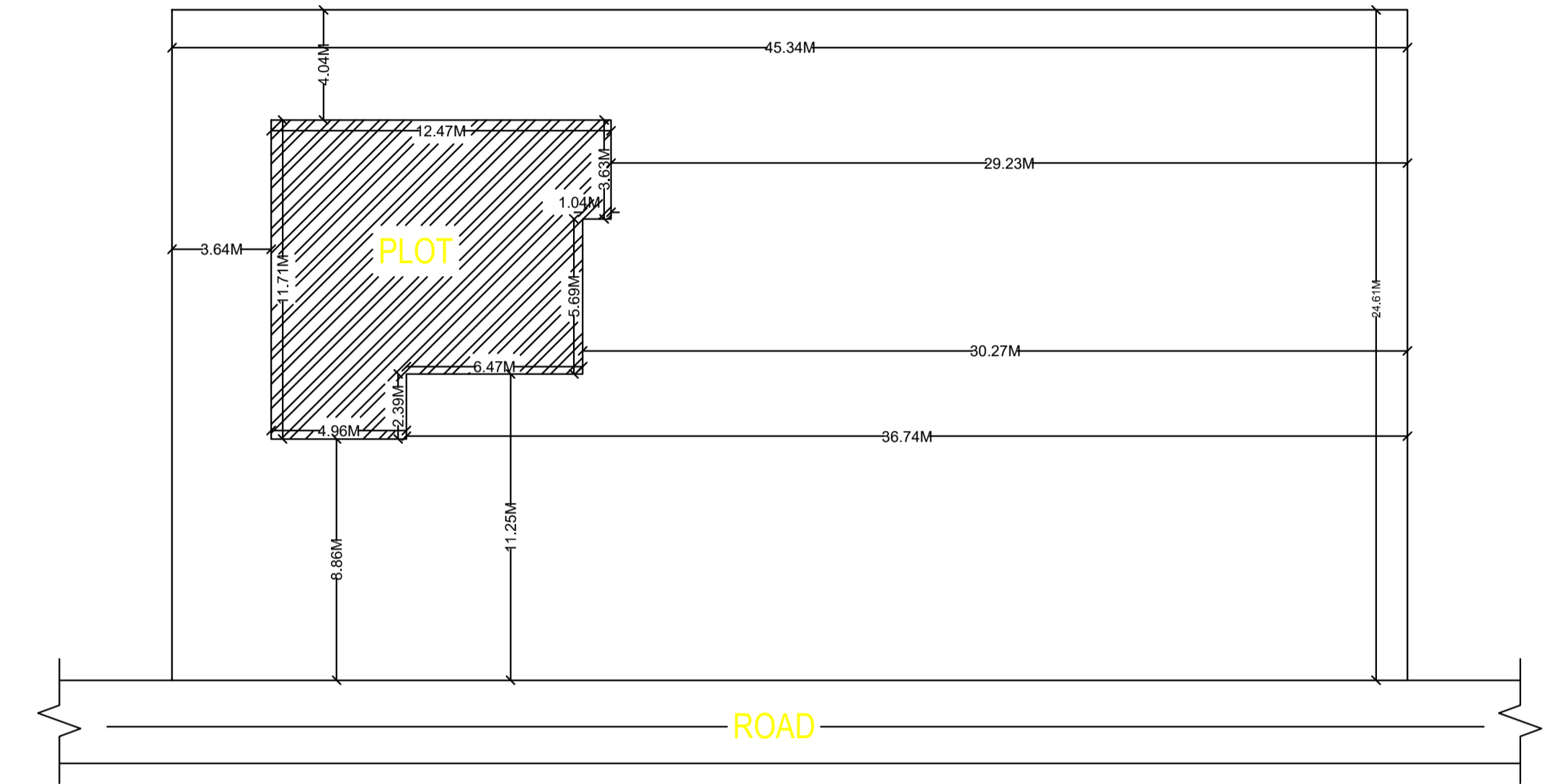

KEY PLAN
SCALE 1:200

LTP NAME AND SIGNATURE	STRUCTURAL ENG'S NAME AND SIGNATURE	BUILDER NAME AND SIGNATURE	DIGITAL SIGNATURE
RAM RATAN SINGH SINPC/DFTMN/0003/2020			