

Proposal Basic Information	
Proposal File No.	SINPC/BP/0209/W02/2021
Owner Name	LAXMI DEVI
Khata No	215
Plot No	5038
Village Name	Gotra
Use	Residential
SubUse	Bungalow/ Dwelling / Non Apartment

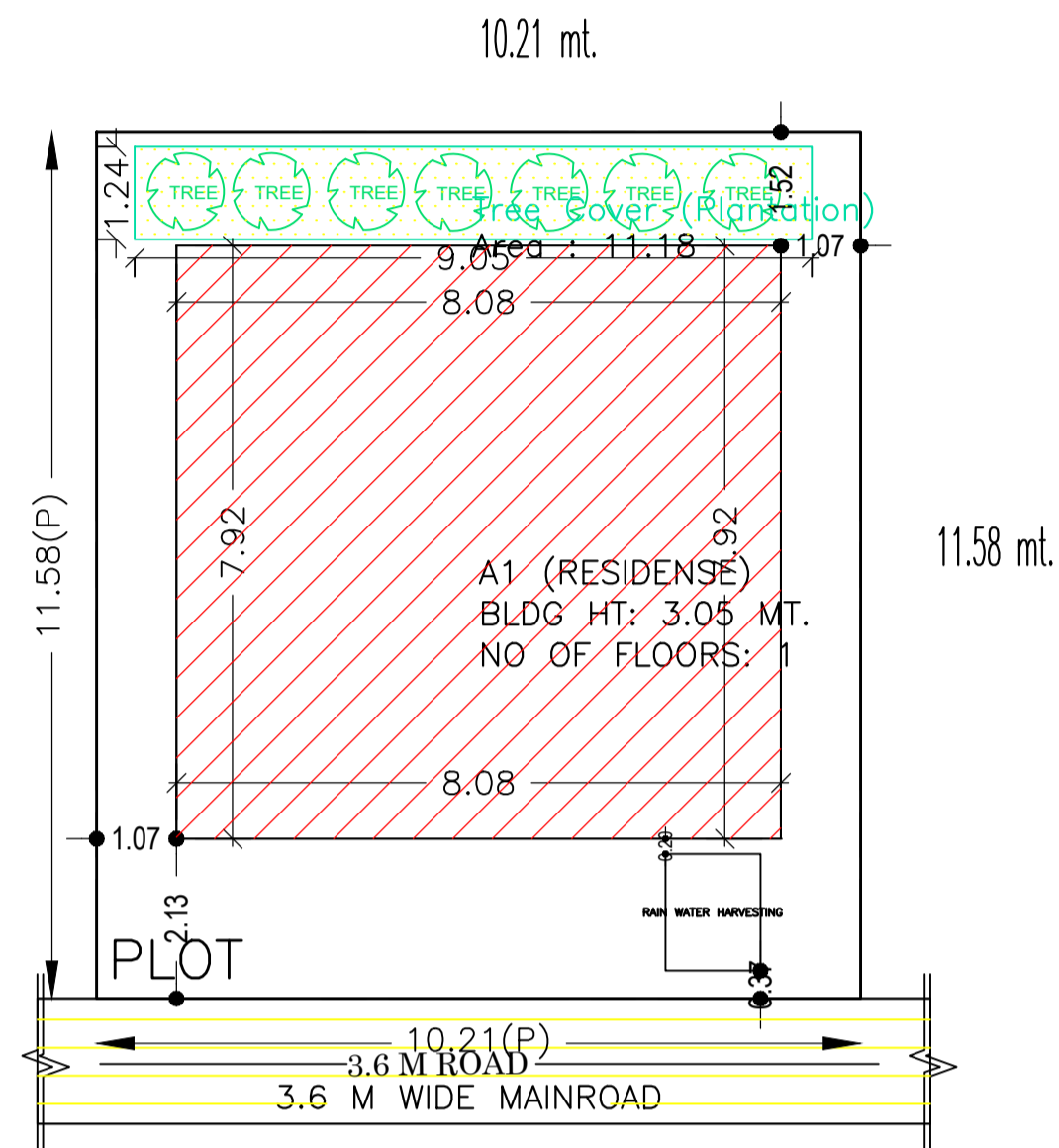

SITE PLAN

AREA STATEMENT SIMDEGA NAGAR PANCHAYAT		VERSION NO: 1.0.54
PROJECT DETAIL:		VERSION DATE: 16/10/2020
Region: JHARKHAND URBAN LOCAL BODIES	Plot Use: Residential	
District: SIMDEGA	Plot SubUse: Bungalow/ Dwelling / Non Apartment	
Authority: SIMDEGA NAGAR PANCHAYAT	PlotNearby/ReligiousStructure: NA	
Inward No: SINPC/BP/0209/W02/2021	Plot/SubPlot No: 5038	
Application Type: General Proposal	North: -	
Project Type: Building Permission	South: -	
Nature of Development: New	East: -	
Location of Development Area: Old Area	West: -	
AREA DETAILS:		SQ.MT.
AREA OF PLOT (Minimum)	(A)	118.27
NET AREA OF PLOT(Gross Plot Area - Deduction from Gross Plot area)	(A-Deductions)	118.27
Deduction for Balance Plot Area(from Gross Plot Area)		
Common Plot		11.18
Total		11.18
BALANCE AREA OF PLOT(Net Plot Area - Recreational/Amenity space)	(A-Deductions)	107.09
PLOT AREA FOR COVERAGE(Net Plot Area)	(A-Deductions)	118.27
Plot Area for FAR (Net Plot Area + RoadWidening Area)	(A-Deductions)	118.27
COVERAGE CHECK		
Permissible Coverage area (70.00 %)		82.79
Proposed Coverage Area (54.12 %)		64.01
Total Prop. Coverage Area (54.12 %)		64.01
Balance coverage area (15.88 %)		18.78
FAR CHECK		
Perm. FAR Area (1.50)		177.40
Total Perm. FAR area		177.40
Residential FAR		64.01
Proposed FAR Area		64.01
Total Proposed FAR Area		64.01
Consumed FAR (Factor)		0.54
Balance FAR Area		113.39
BUILT UP AREA CHECK		
Total Proposed BuiltUp Area		64.01
ARCHITECT (Regd)	RAM RATAN SINGH	
ENGINEER (Regd)		
SUPERVISOR (Regd)		
OWNER (Regd)	LAXMI DEVI	
DEVELOPMENT AUTHORITY	LOCAL BODY	

COLOR INDEX	
PLOT BOUNDARY	Black
ABUTTING ROAD	Green
PROPOSED CONSTRUCTION	Red
COMMON PLOT	Yellow
ROAD WIDENING AREA	Orange
EXISTING (To be retained)	Blue
EXISTING (To be demolished)	Light Blue

FAR & Tenement Details (Table 4c-1)

Building	No. of Same Bldg	Total Built Up Area (Sq.mt.)	Proposed FAR Area (Sq.mt.) Res.	Total FAR Area (Sq.mt.)	Total Consumed Additional FAR Area (Sq.mt.)	Tnmt (No.)
A1 (RESIDENSE)	1	64.01	64.01	64.01	64.01	01
Grand Total :	1	64.01	64.01	64.01	64.01	01

Building USE/SUBUSE Details

Building Name	Building Use	Building SubUse	Building Structure
A1 (RESIDENSE)	Residential	Bungalow/ Dwelling / Non Apartment	Non-Highrise

Buildingwise Floor FAR Details

Floor Name	Building Name A1 (RESIDENSE)		Total	
	Proposed Built Up Area (Sq.mt.)	Proposed FAR Area (Sq.mt.)	Total Proposed Built Up Area (Sq.mt.)	Total FAR Area (Sq.mt.)
Ground Floor	64.01	64.01	64.01	64.01
Terrace Floor	0.00	0.00	0.00	0.00
Total :	64.01	64.01	64.01	64.01

LTP NAME AND SIGNATURE	STRUCTURAL ENG'S NAME AND SIGNATURE	BUILDER NAME AND SIGNATURE	DIGITAL SIGNATURE
RAM RATAN SINGH SINPC/DFTMN/0003/2020			

Proposal Basic Information	
Proposal File No.	SINPC/BP/0209/W02/2021
Owner Name	LAXMI DEVI
Khata No	215
Plot No	5038
Village Name	Gotra
Use	Residential
SubUse	Bungalow/ Dwelling / Non Apartment

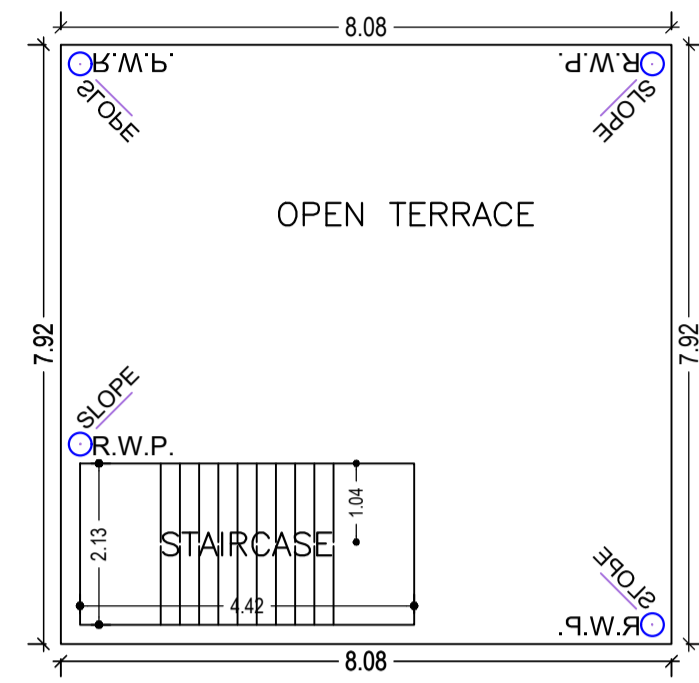

TERRACE FLOOR PLAN
(SCALE 1:100)

Building :A1 (RESIDENSE)

Floor Name	Total Built Up Area (Sq.mt.)	Proposed FAR Area (Sq.mt.) Res.	Total FAR Area (Sq.mt.)	Total Consumed Additional FAR Area (Sq.mt.)	Trmt (No.)
Ground Floor	64.01	64.01	64.01	64.01	01
Terrace Floor	0.00	0.00	0.00	0.00	00
Total :	64.01	64.01	64.01	64.01	01
Total Number of Same Buildings :	1				
Total :	64.01	64.01	64.01	64.01	01

SCHEDULE OF DOOR:

BUILDING NAME	NAME	LENGTH	HEIGHT	NOS
A1 (RESIDENSE)	D1	0.76	2.10	01
A1 (RESIDENSE)	D	1.07	2.10	04

SCHEDULE OF WINDOW/VENTILATION:

BUILDING NAME	NAME	LENGTH	HEIGHT	NOS
A1 (RESIDENSE)	V	0.61	1.20	01
A1 (RESIDENSE)	W1	1.22	1.20	01
A1 (RESIDENSE)	W	1.52	1.20	03

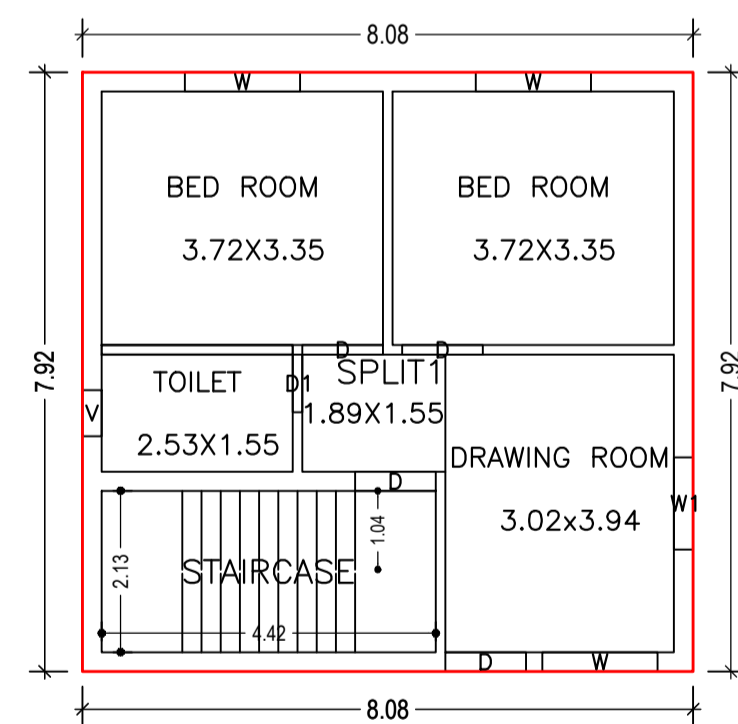

GROUND FLOOR PLAN
(Proposed)
(SCALE 1:100)

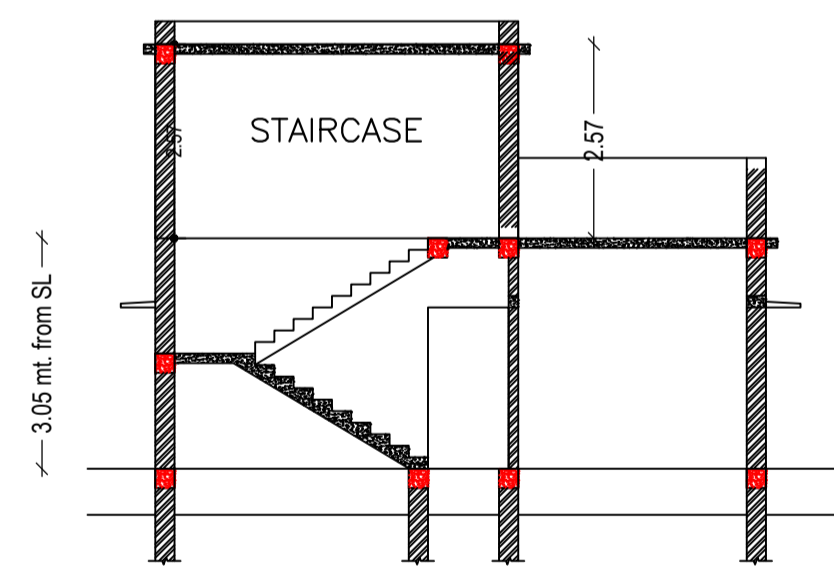

SECTION AT-X-X
SCALE 1:100

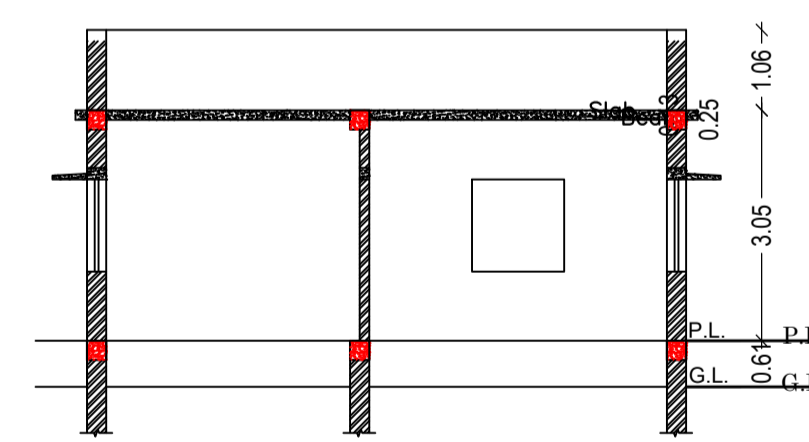

SECTION AT-Y-Y
SCALE 1:100

UnitBUA Table for Building :A1 (RESIDENSE)

FLOOR	Name	UnitBUA Type	UnitBUA Area	Carpet Area	No. of Rooms	No. of Tenement
GROUND FLOOR PLAN	SPLIT1	FLAT	45.28	44.96	4	1
Total:	-	-	45.28	44.96	4	1

LTP NAME AND SIGNATURE	STRUCTURAL ENG'S NAME AND SIGNATURE	BUILDER NAME AND SIGNATURE	DIGITAL SIGNATURE
RAM RATAN SINGH SINPC/DFTMN/0003/2020			

Proposal Basic Information	
Proposal File No.	SINPC/BP/0209/W02/2021
Owner Name	LAXMI DEVI
Khata No	215
Plot No	5038
Village Name	Gotra
Use	Residential
SubUse	Bungalow/ Dwelling / Non Apartment

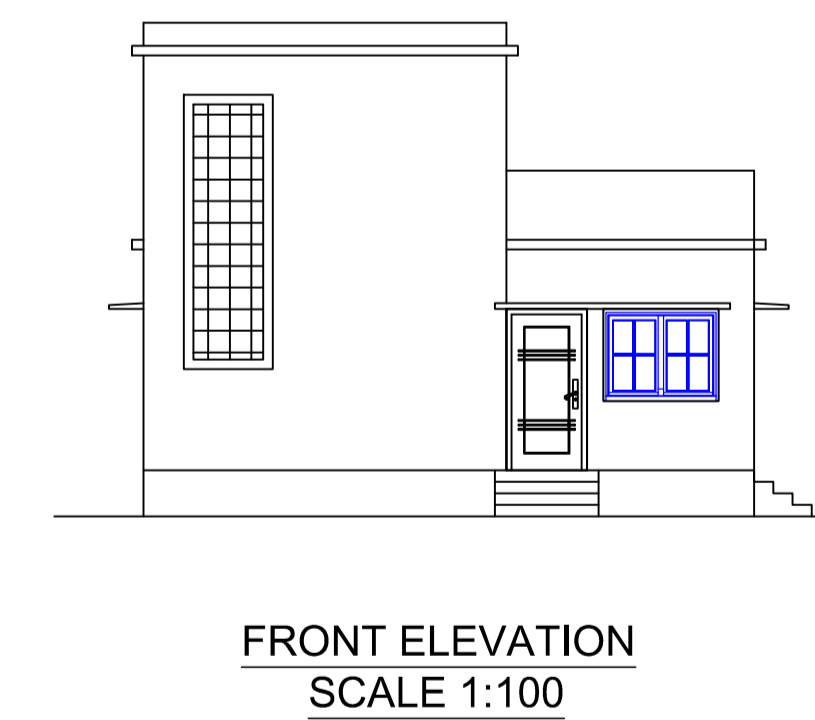
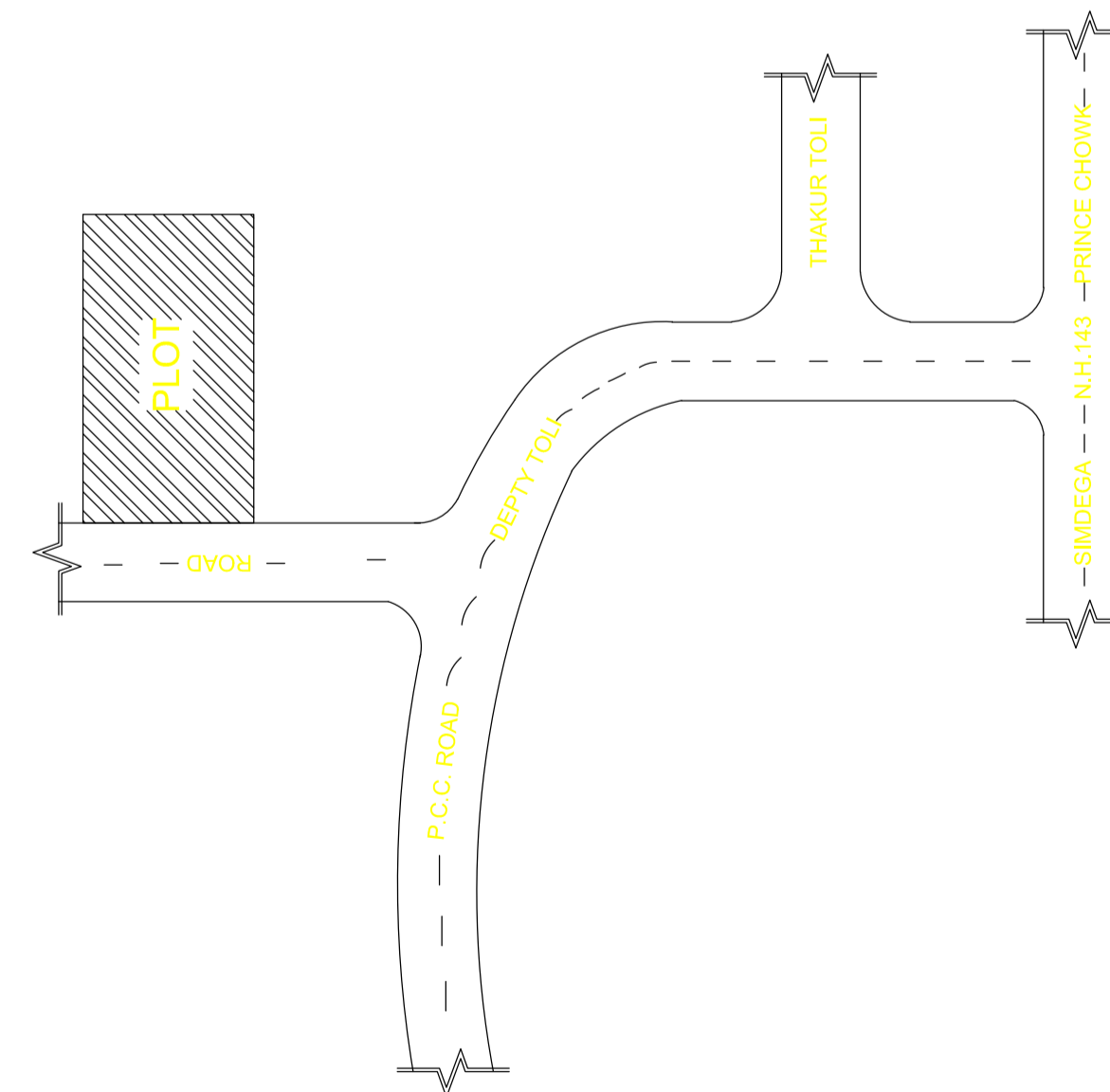
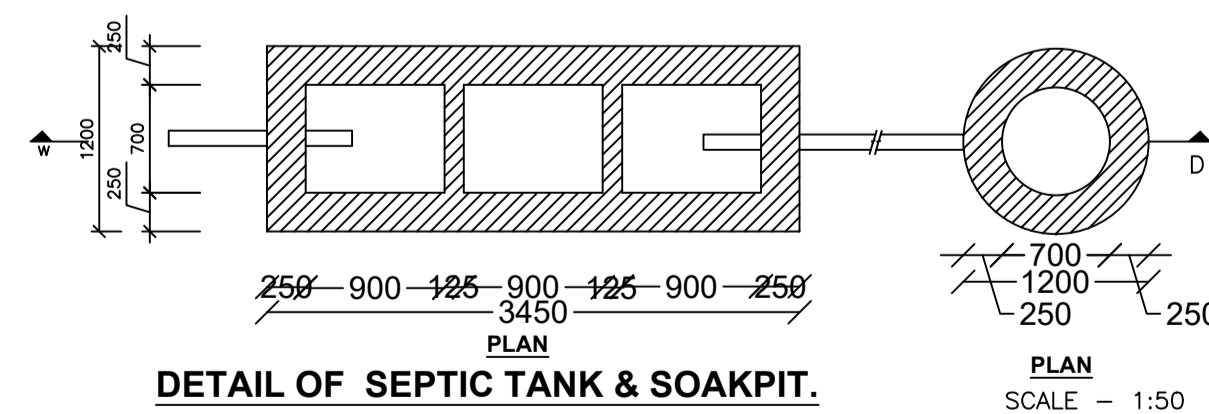
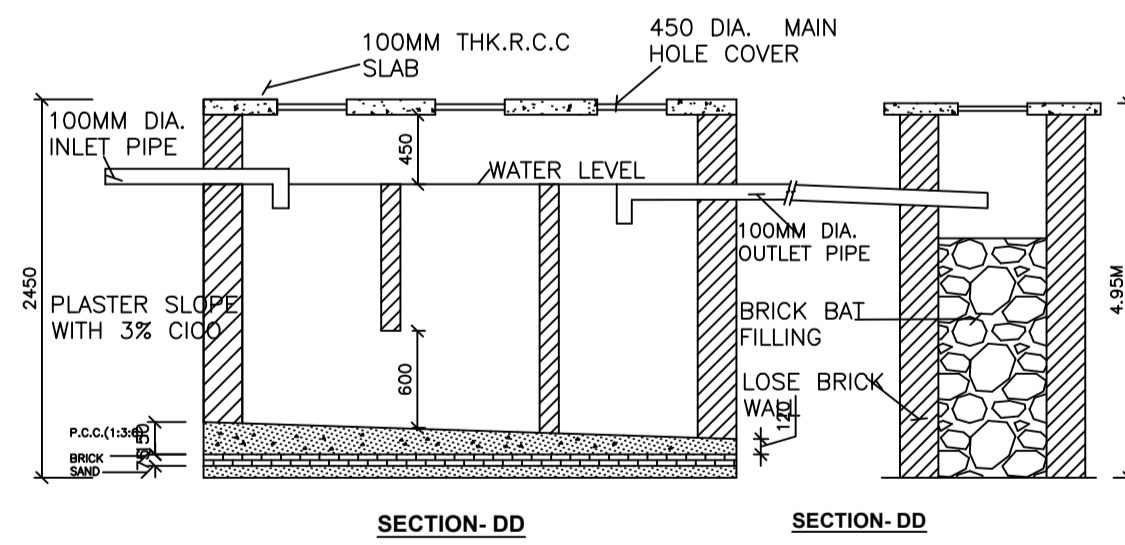
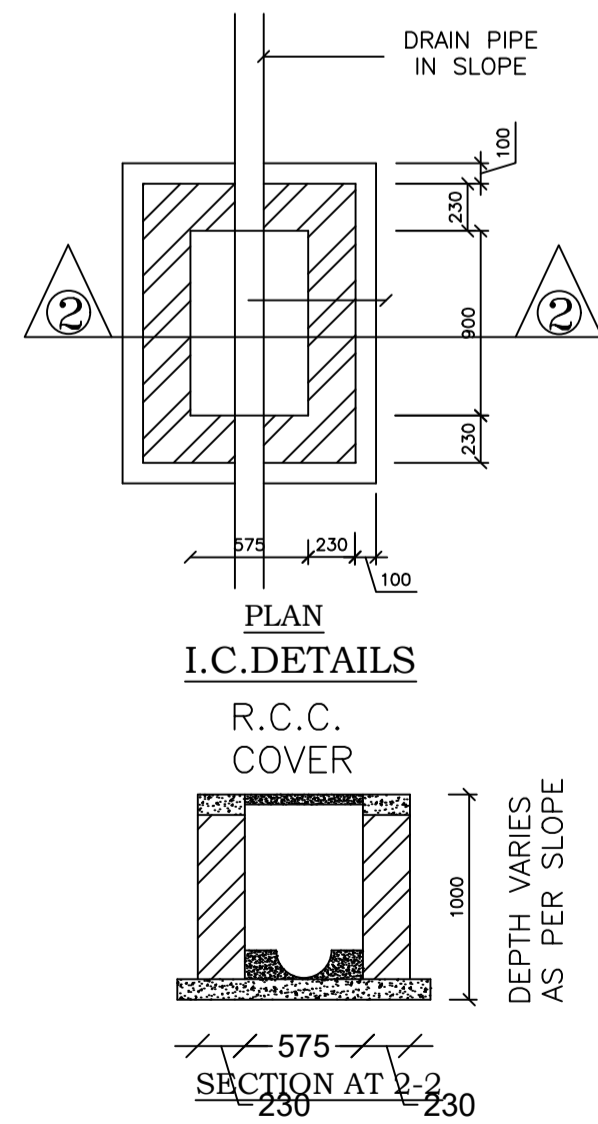
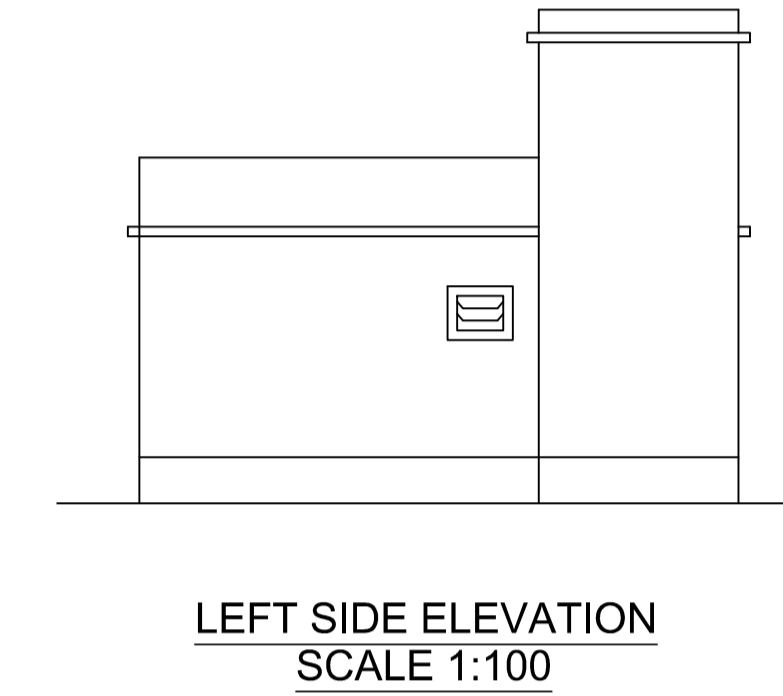
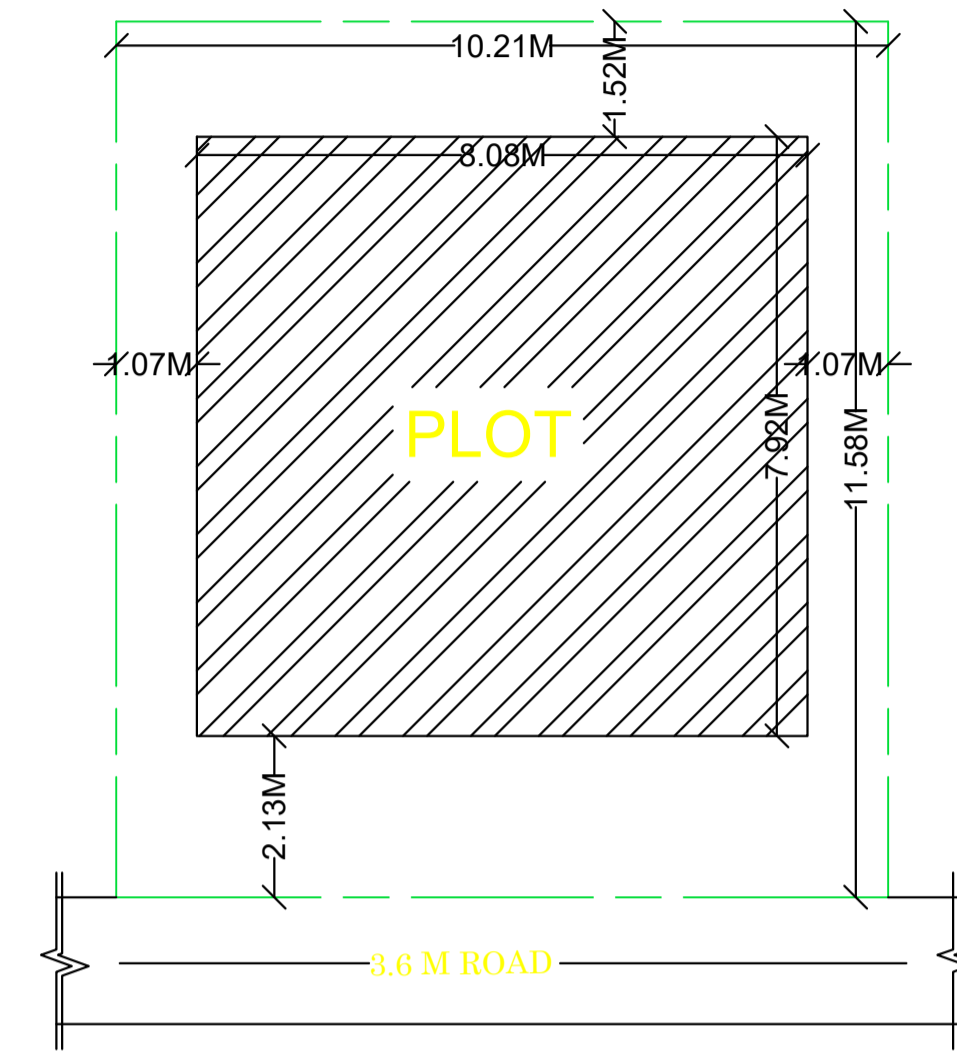
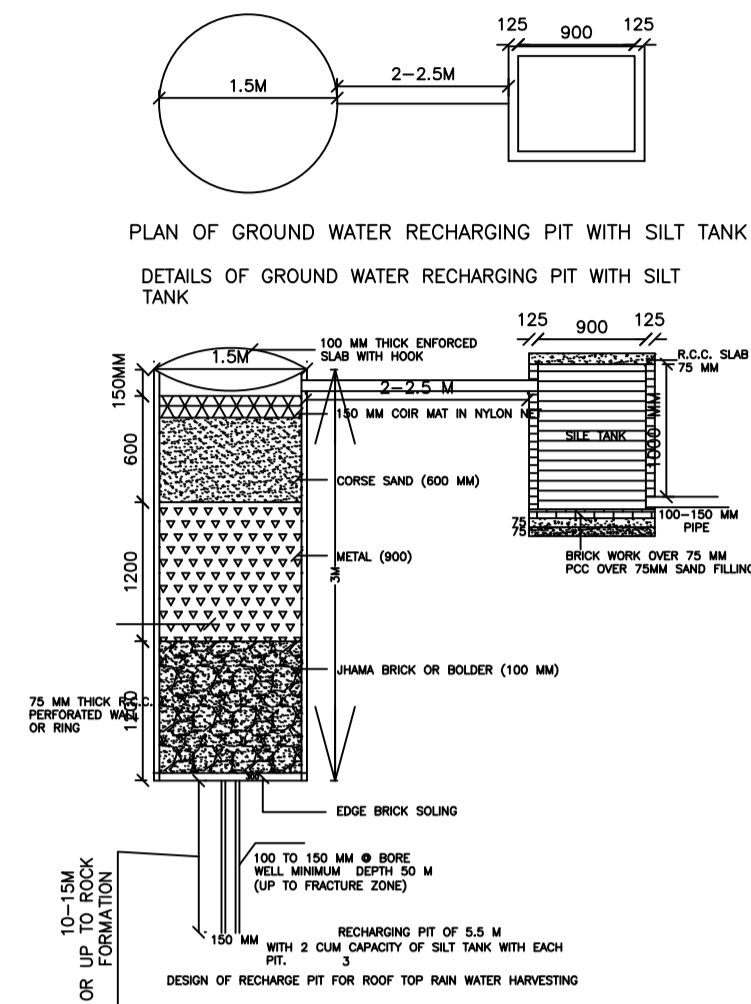
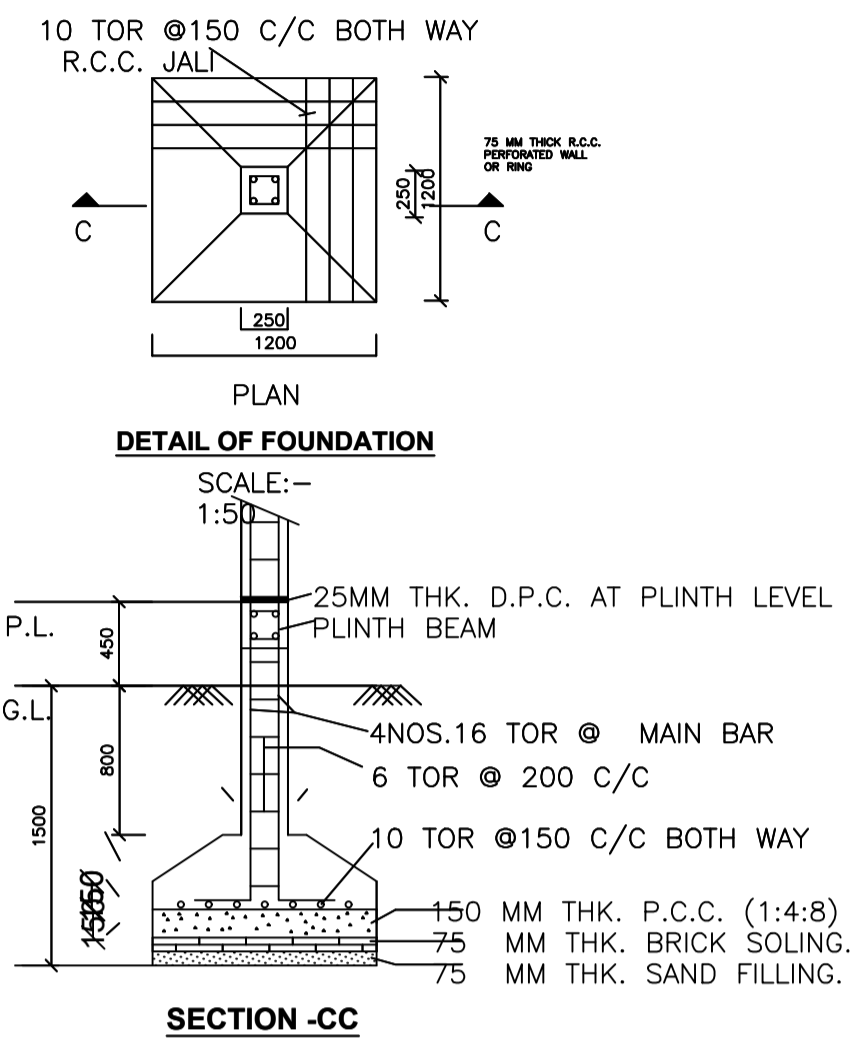

LTP NAME AND SIGNATURE	STRUCTURAL ENG'S NAME AND SIGNATURE	BUILDER NAME AND SIGNATURE	DIGITAL SIGNATURE
RAM RATAN SINGH SINPC/DFTMN/0003/2020			