

SITE PLAN

FAR & Tenement Details (Table 4c-1)

Building	No. of Same Bldg	Total Built Up Area (Sq.mt.)	Proposed FAR Area (Sq.mt.) Resi.	Total FAR Area (Sq.mt.)	Total Consumed Additional FAR Area (Sq.mt.)	Tnmt (No.)
A1 (RESIDENCE)	1	277.78	277.78	277.78	277.78	02
Grand Total :	1	277.78	277.78	277.78	277.78	02

Proposal Basic Information

Proposal File No.	SINPC/BP/0201/W02/2021
Owner Name	MICHAEL TIRKEY
Khata No	102
Plot No	2496
Village Name	Gotra
Use	Residential
SubUse	Bungalow/ Dwelling / Non Apartment

Required Parking (Table 7a)

Building Name	Type	SubUse	Area (Sq.mt.)	Units		Car		Visitors Car		TwoWheeler	
				Reqd.	Prop.	Reqd./Unit	Prop.	Reqd./Unit	Prop.	Reqd./Unit	Prop.
A1 (RESIDENCE)	Residential	Residential Bldg/Apartment	> 0	1	2.00	1	2	-	-	-	-
			> 0	1	2.00	-	-	-	-	1	2
			> 0	1	2.00	-	-	1	1	-	-
Total :			-	-	-	-	2	2	-	1	2

Parking Check (Table 7b)

Vehicle Type	Reqd.		Prop.	
	No.	Area	No.	Area
Car	-	-	2	25.00
Total Car	2	25.00	2	25.00
Visitor's Car Parking	-	-	2	25.09
Total Visitor Parking	1	12.50	2	25.09
TwoWheeler	-	-	4	8.73
Total TwoWheeler	2	4.00	4	8.73
Total		41.50		67.55

AREA STATEMENT SIMDEGA NAGAR PANCHAYAT	VERSION NO. : 1.0.53
PROJECT DETAIL:	VERSION DATE: 16/10/2020
Region: JHARKHAND URBAN LOCAL BODIES	Plot Use: Residential
District: SIMDEGA	Plot SubUse: Bungalow/ Dwelling / Non Apartment
Authority: SIMDEGA NAGAR PANCHAYAT	PlotNearby/ReligiousStructure: NA
Inward No: SINPC/BP/0201/W02/2021	Plot/SubPlot No: 2496
Application Type: General Proposal	North: -
Project Type: Building Permission	South: -
Nature of Development: New	East: -
Location of Development Area: Old Area	West: -
AREA DETAILS:	SQ.MT.
AREA OF PLOT (Minimum)	(A) 601.99
NET AREA OF PLOT(Gross Plot Area - Deduction from Gross Plot area)	(A-Deductions) 601.99
Deduction for Balance Plot Area(from Gross Plot Area)	
Common Plot	39.07
Total	39.07
BALANCE AREA OF PLOT(Net Plot Area - Recreational/Amenity space)	(A-Deductions) 562.92
PLOT AREA FOR COVERAGE(Net Plot Area)	(A-Deductions) 601.99
Plot Area for FAR (Net Plot Area + Road Widening Area)	(A-Deductions) 601.99
COVERAGE CHECK	
Permissible Coverage area (60.00 %)	361.19
Proposed Coverage Area (23.07 %)	138.89
Total Prop. Coverage Area (23.07 %)	138.89
Balance coverage area (36.93 %)	222.30
FAR CHECK	
Perm. FAR Area (1.50)	902.98
Total Perm. FAR area	902.98
Residential FAR	277.77
Proposed FAR Area	277.77
Total Proposed FAR Area	277.77
Consumed FAR (Factor)	0.46
Balance FAR Area	625.21
BUILT UP AREA CHECK	
Total Proposed BuiltUp Area	277.78
ARCHITECT (Regd)	RAM RATAN SINGH
ENGINEER (Regd)	
SUPERVISOR (Regd)	
OWNER (Regd)	MICHAEL TIRKEY
DEVELOPMENT AUTHORITY LOCAL BODY	

COLOR INDEX	
PLOT BOUNDARY	Black
ABUTTING ROAD	Green
PROPOSED CONSTRUCTION	Red
COMMON PLOT	Yellow
ROAD WIDENING AREA	Orange
EXISTING (To be retained)	Blue
EXISTING (To be demolished)	Light Blue

Buildingwise Floor FAR Details

Floor Name	Building Name A1 (RESIDENCE)		Total	
	Proposed Built Up Area (Sq.mt.)	Proposed FAR Area (Sq.mt.)	Total Proposed Built Up Area (Sq.mt.)	Total FAR Area (Sq.mt.)
Ground Floor	138.89	138.89	138.89	138.89
First Floor	138.89	138.89	138.89	138.89
Terrace Floor	0.00	0.00	0.00	0.00
Total :	277.78	277.78	277.78	277.78

Building USE/SUBUSE Details

Building Name	Building Use	Building SubUse	Building Structure
A1 (RESIDENCE)	Residential	Residential Bldg/Apartment	Non-Highrise

LTP NAME AND SIGNATURE	STRUCTURAL ENG'S NAME AND SIGNATURE	BUILDER NAME AND SIGNATURE	DIGITAL SIGNATURE
RAM RATAN SINGH SINPC/DFTMN/0003/2020			

Proposal Basic Information

Proposal File No.	SINPC/BP/0201/W02/2021
Owner Name	MICHAEL TIRKEY
Khata No	102
Plot No	2496
Village Name	Goira
Use	Residential
SubUse	Bungalow/ Dwelling / Non Apartment

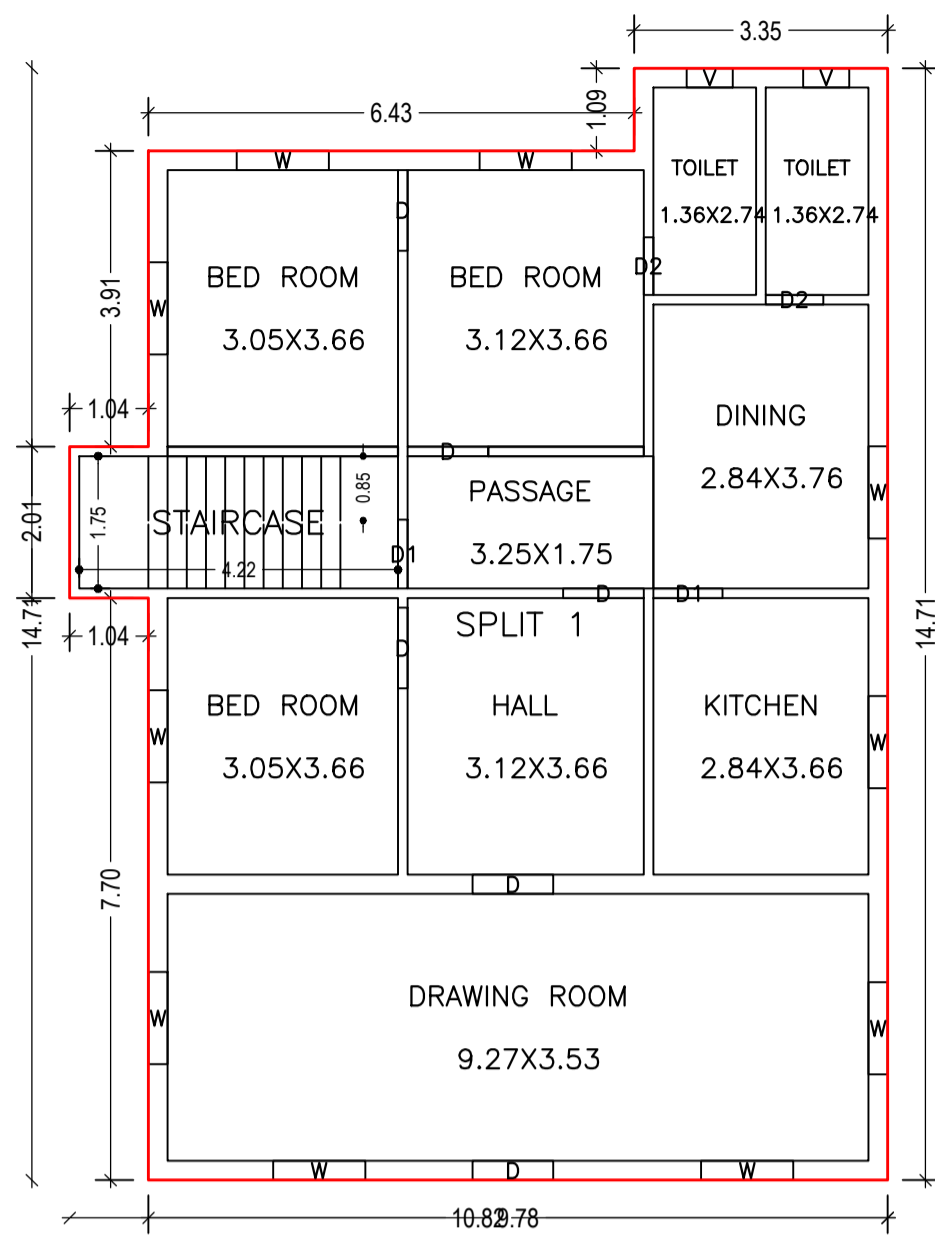

GROUND FLOOR PLAN (Proposed) (SCALE 1:100)

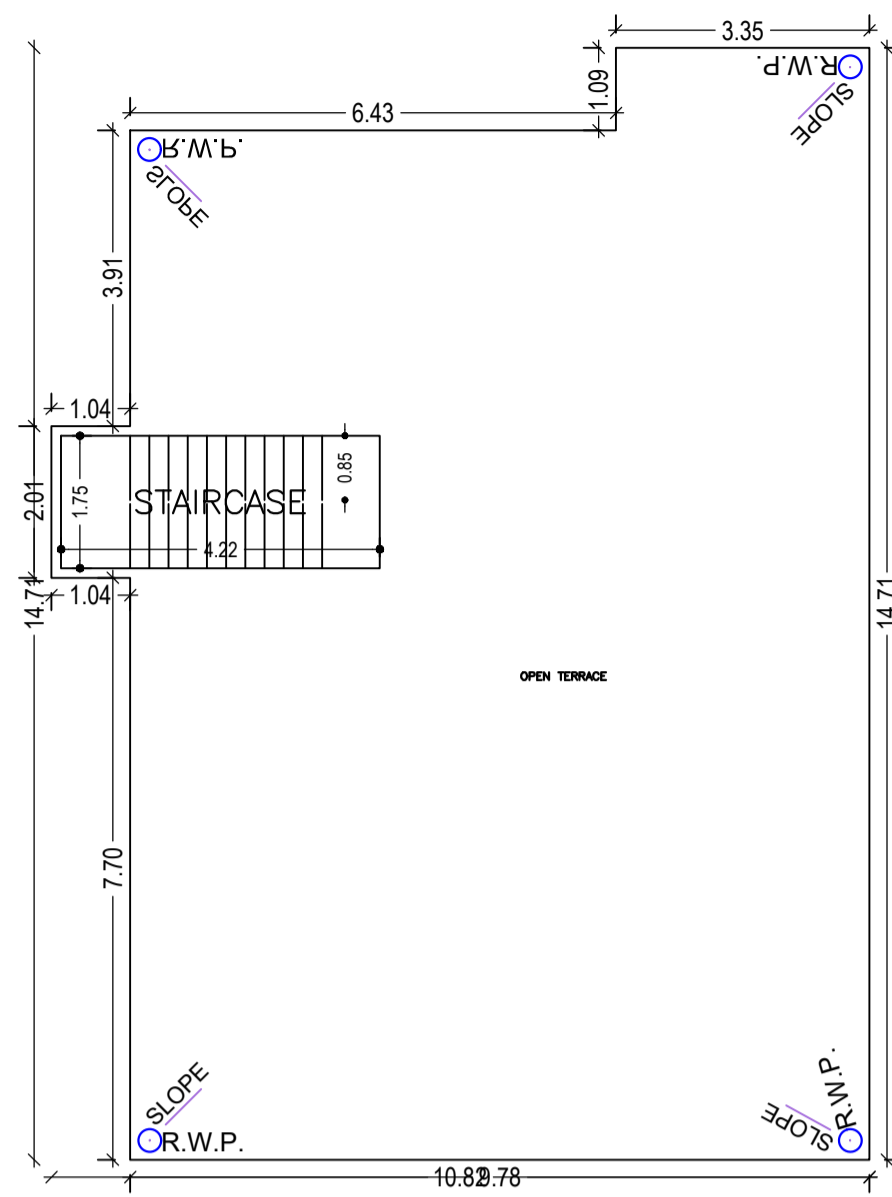

TERRACE FLOOR PLAN (SCALE 1:100)



FRONT ELEVATION (SCALE 1:100)

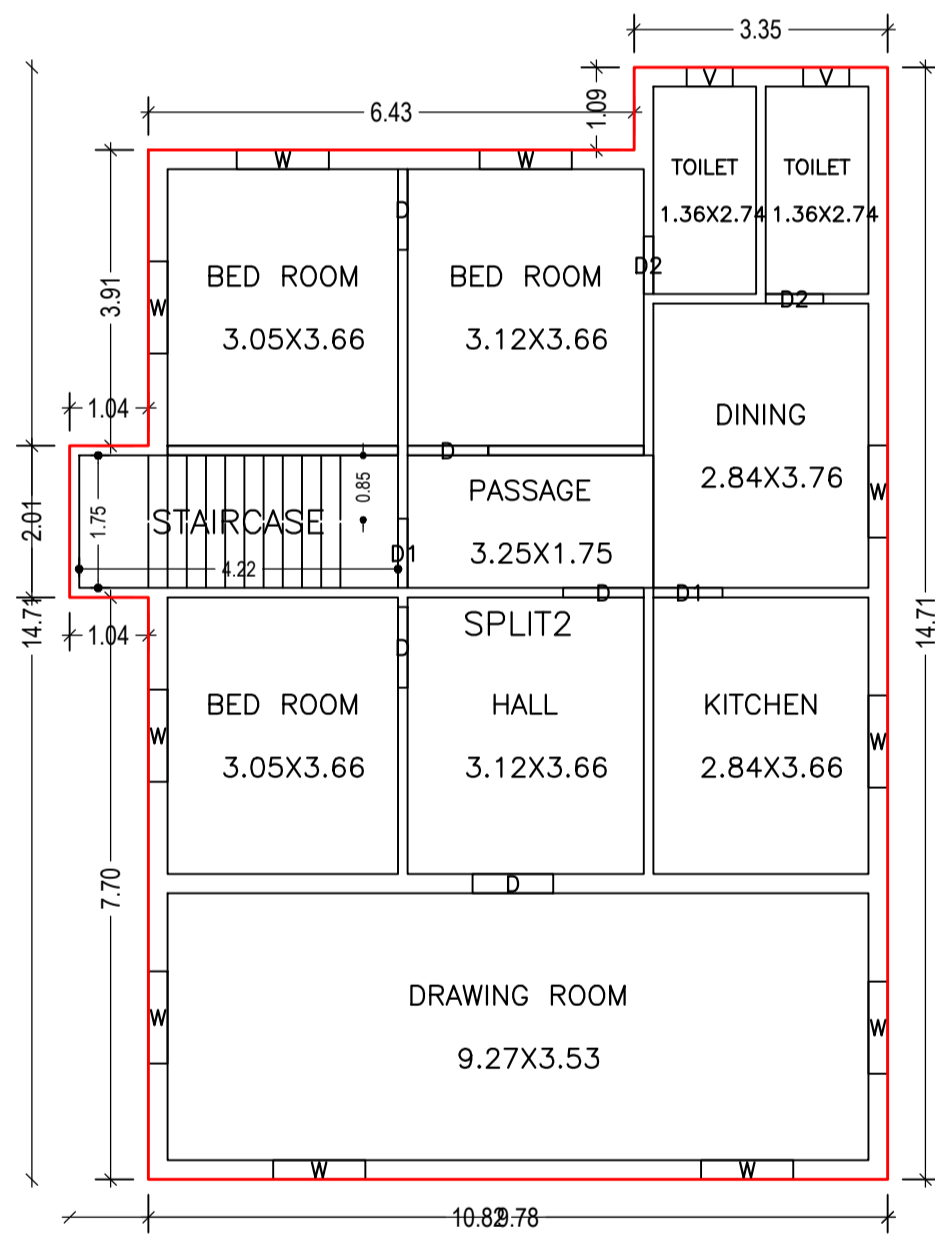
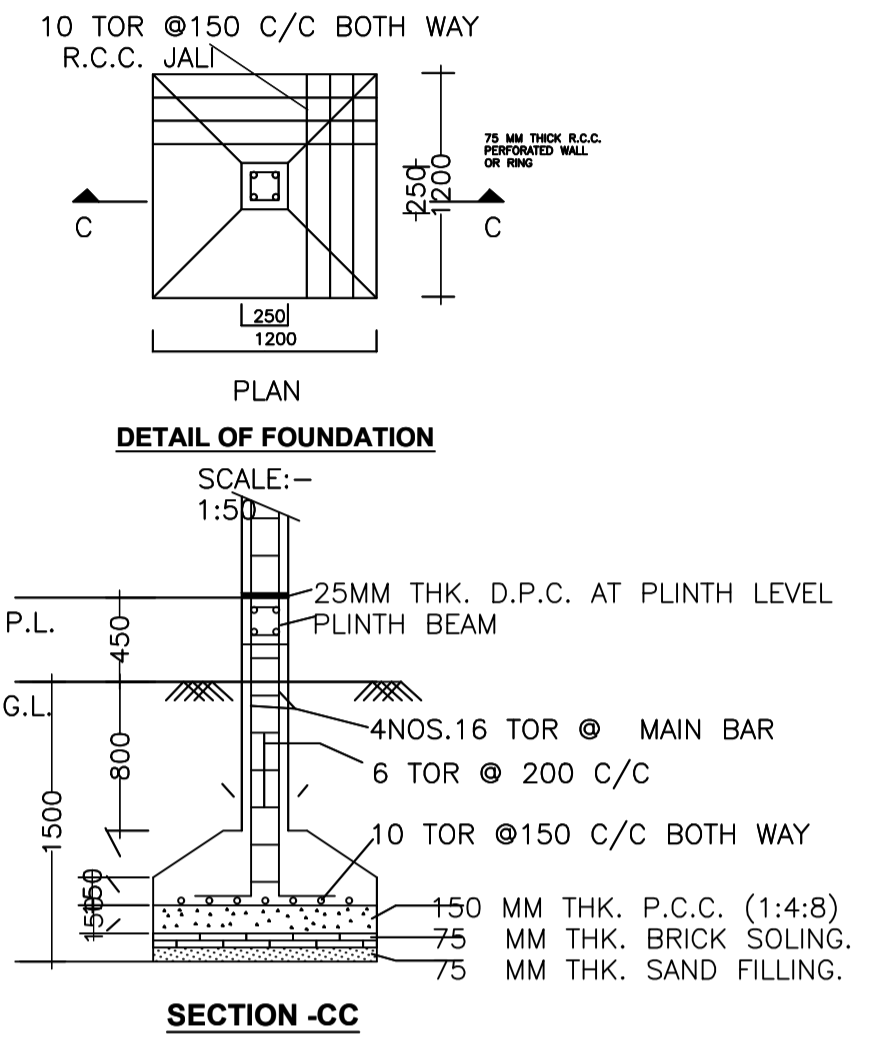
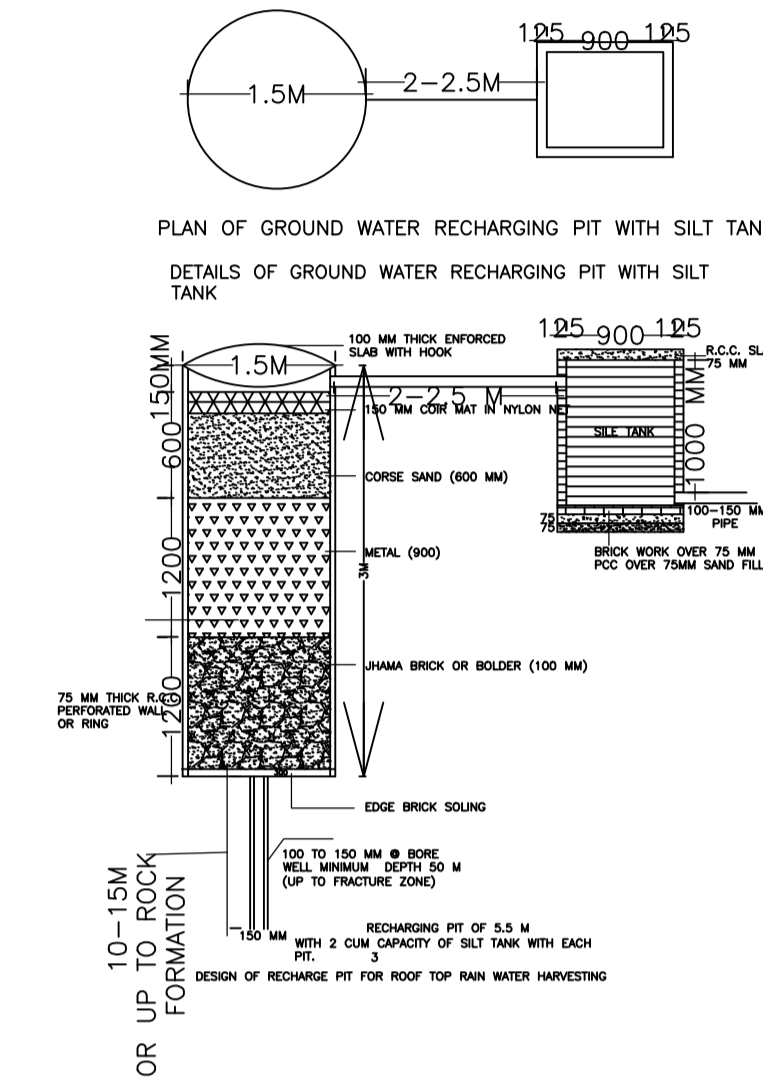

FIRST FLOOR PLAN (Proposed) (SCALE 1:100)

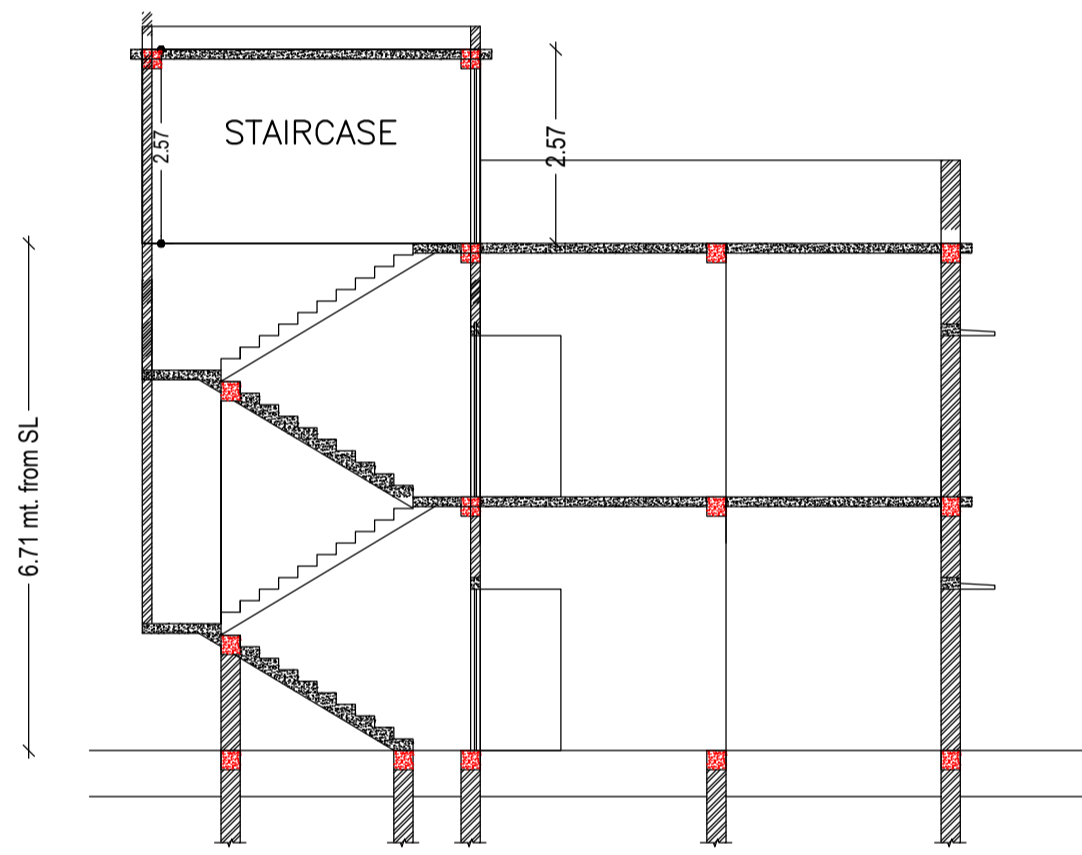

SECTION AT-X-X (SCALE 1:100)

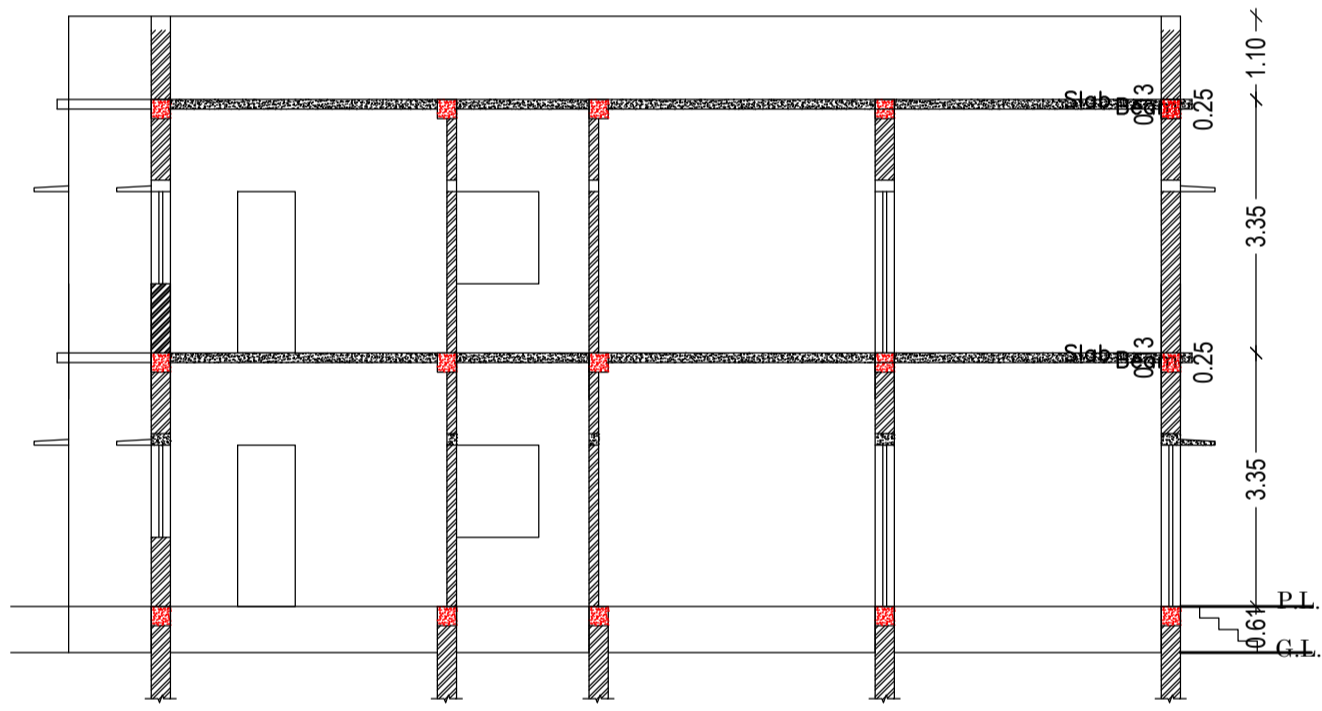

SECTION AT-Y-Y (SCALE 1:100)

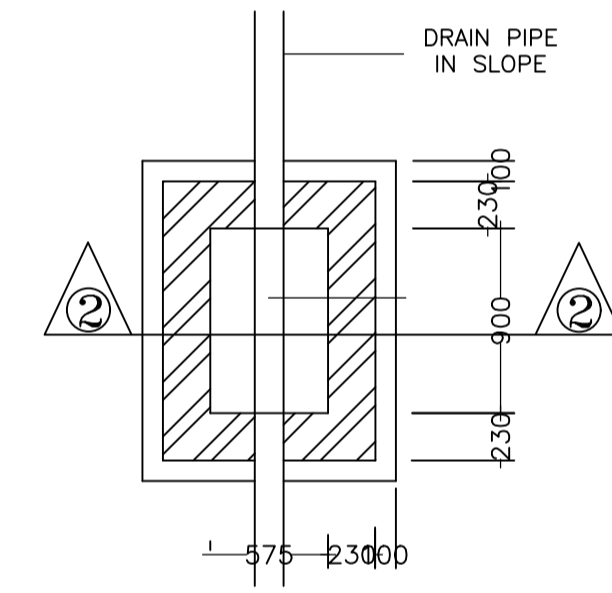

PLAN I.C.DETAILS

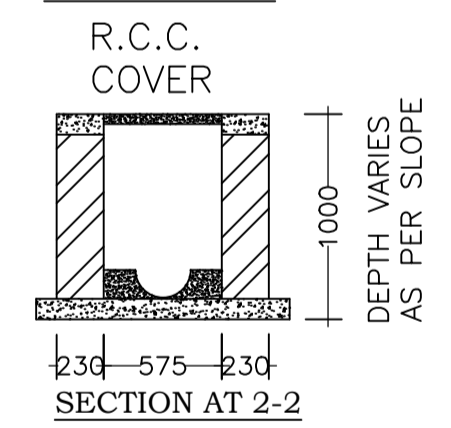

SECTION AT 2-2

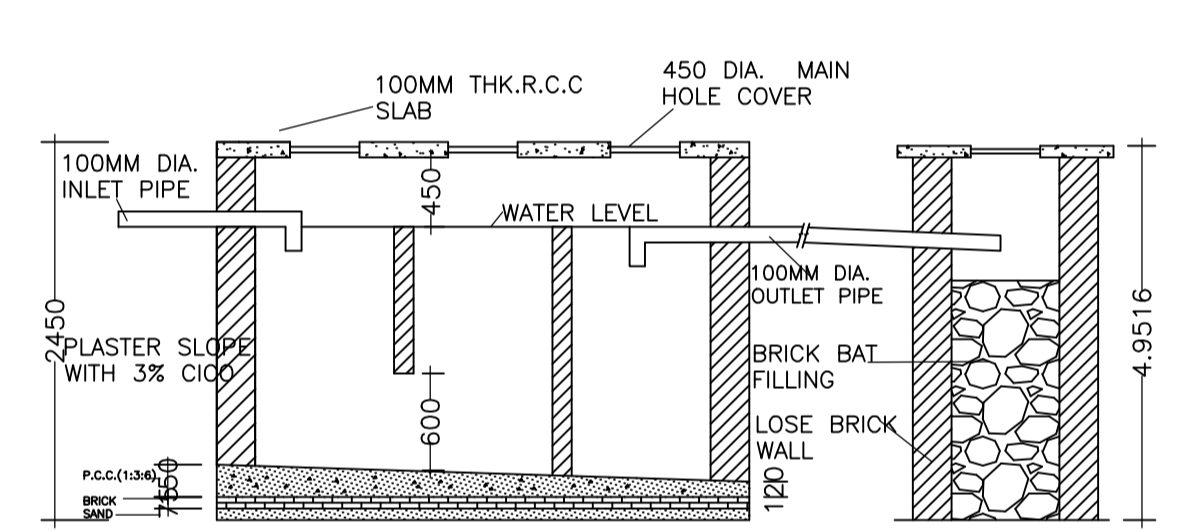

SECTION-DD

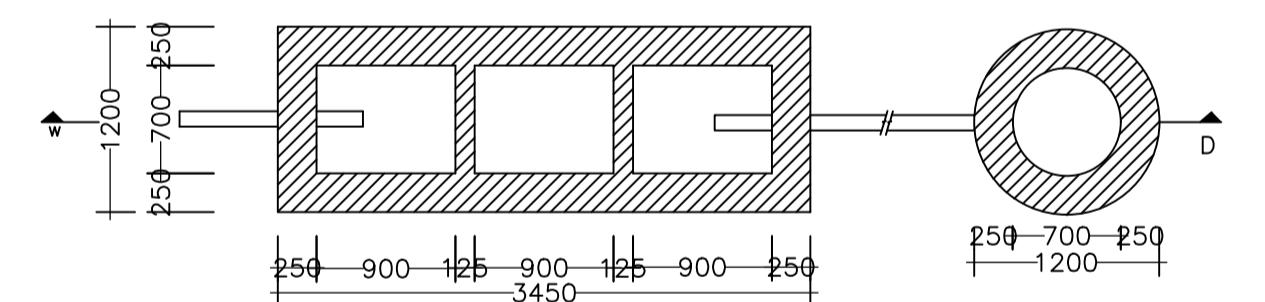

DETAIL OF SEPTIC TANK & SOAKPIT.

PLAN SCALE - 1:50

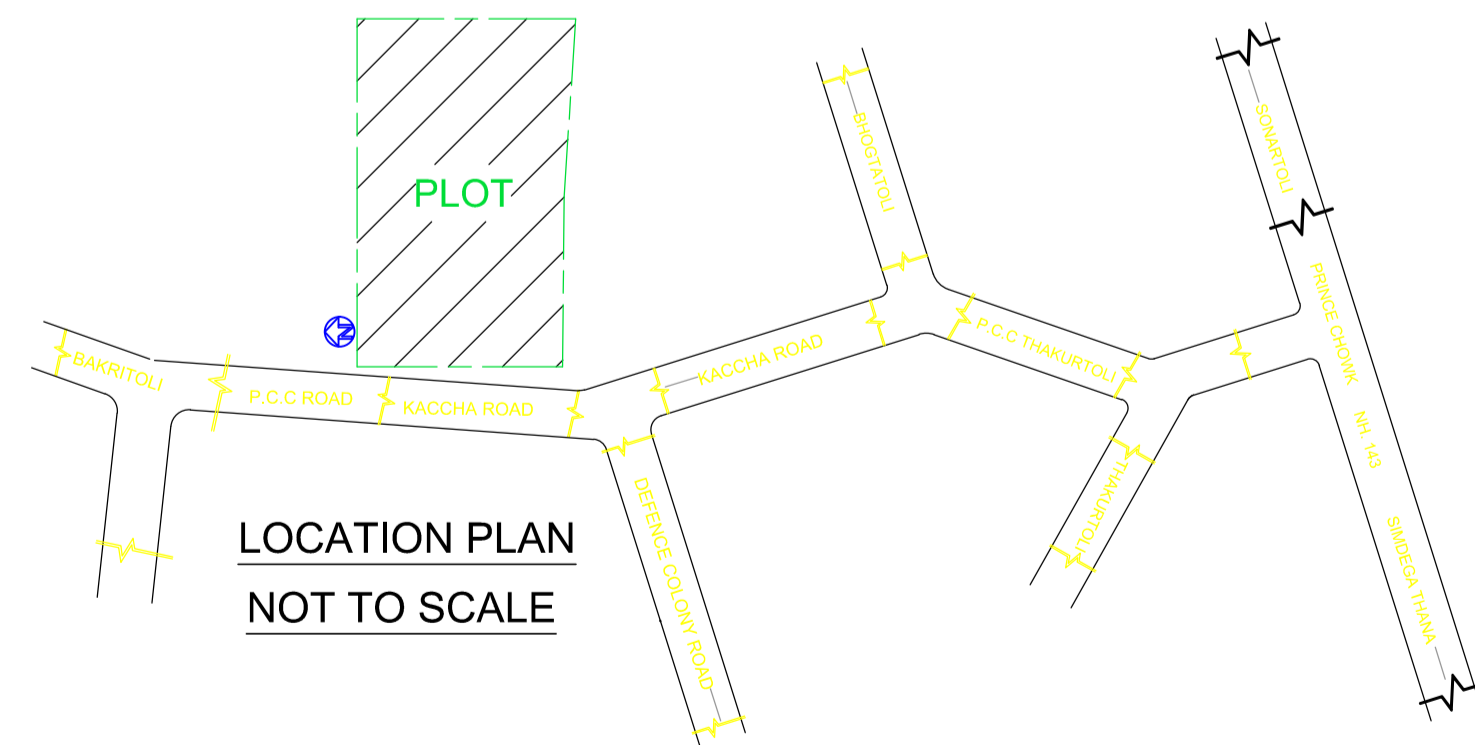

LOCATION PLAN NOT TO SCALE

Building :A1 (RESIDENCE)

Floor Name	Total Built Up Area (Sq.mt.)	Proposed FAR Area (Sq.mt.)	Total FAR Area (Sq.mt.)	Total Consumed Additional FAR Area (Sq.mt.)	Tnmt (No.)
Ground Floor	138.89	138.89	138.89	138.89	01
First Floor	138.89	138.89	138.89	138.89	01
Terrace Floor	0.00	0.00	0.00	0.00	00
Total :	277.78	277.78	277.78	277.78	02
Total Number of Same Buildings	1				
Total :	277.78	277.78	277.78	277.78	02

SCHEDULE OF DOOR:

BUILDING NAME	NAME	LENGTH	HEIGHT	NOS
A1 (RESIDENCE)	D2	0.76	2.10	04
A1 (RESIDENCE)	D1	0.91	2.10	04
A1 (RESIDENCE)	D	1.07	2.10	11

SCHEDULE OF WINDOW/VENTILATION:

BUILDING NAME	NAME	LENGTH	HEIGHT	NOS
A1 (RESIDENCE)	V	0.61	1.20	04
A1 (RESIDENCE)	W	1.22	1.20	20

UnitBUA Table for Building :A1 (RESIDENCE)

FLOOR	Name	UnitBUA Type	UnitBUA Area	Carpet Area	No. of Rooms	No. of Tenement
GROUND FLOOR PLAN	SPLIT 1	FLAT	118.25	117.98	10	1
FIRST FLOOR PLAN	SPLIT2	FLAT	118.25	117.98	10	1
Total:	-	-	236.50	235.96	20	2

LTP NAME AND SIGNATURE	STRUCTURAL ENG'S NAME AND SIGNATURE	BUILDER NAME AND SIGNATURE	DIGITAL SIGNATURE
RAM RATAN SINGH SINPC/DFTMN/0003/2020			

Proposal Basic Information	
Proposal File No.	SINPC/BP/0201/W02/2021
Owner Name	MICHAEL TIRKEY
Khata No	102
Plot No	2496
Village Name	Gotra
Use	Residential
SubUse	Bungalow/ Dwelling / Non Apartment

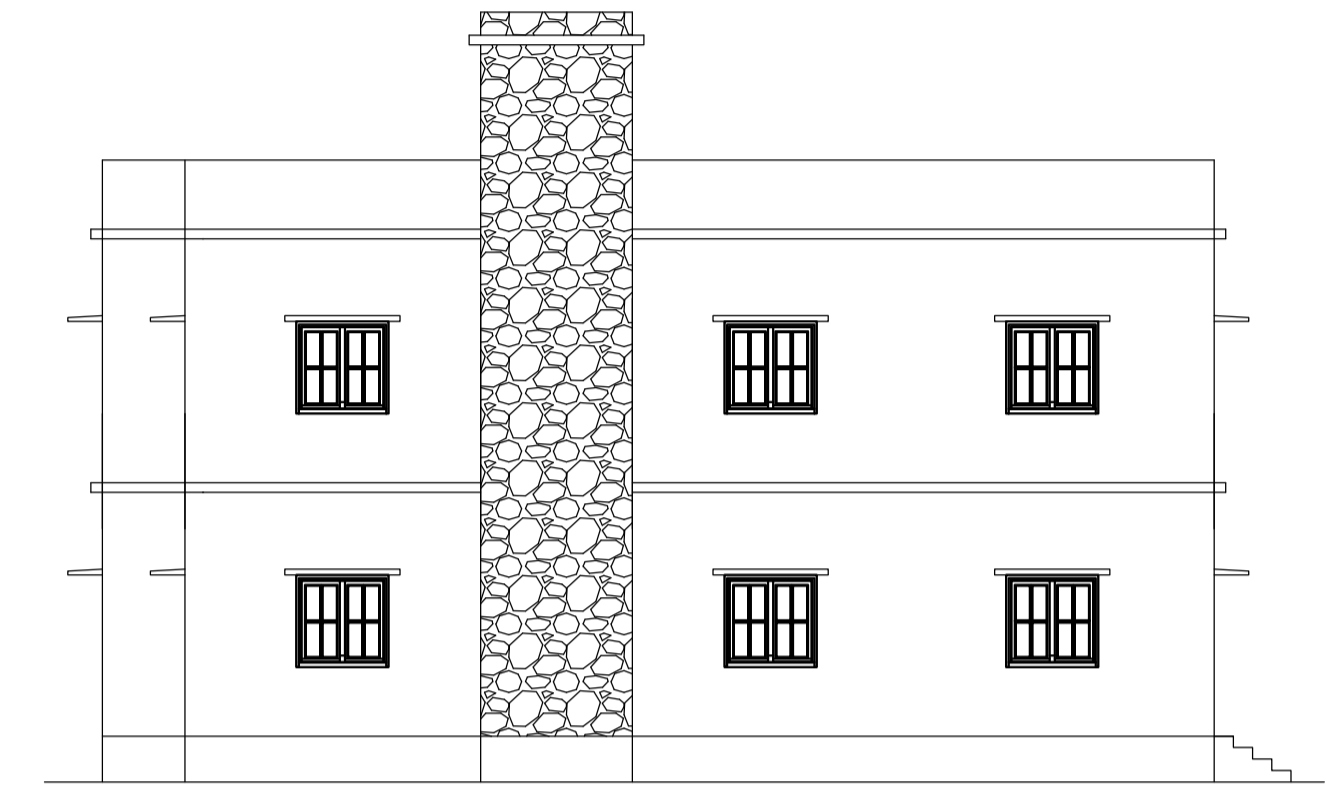

LEFT SIDE ELEVATION
SCALE 1:100

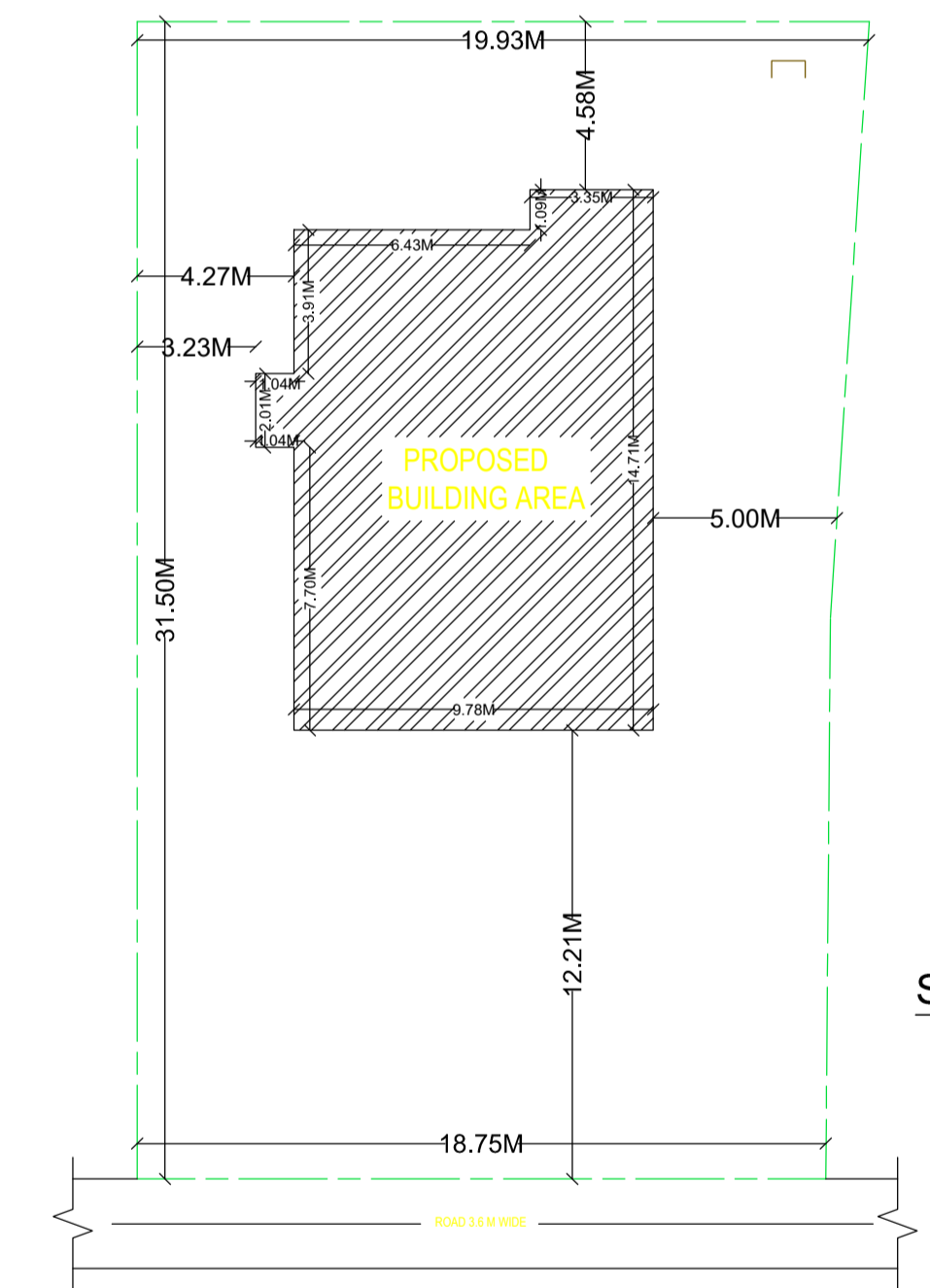

KEY PLAN
SCALE 1:200

LTP NAME AND SIGNATURE	STRUCTURAL ENG'S NAME AND SIGNATURE	BUILDER NAME AND SIGNATURE	DIGITAL SIGNATURE
RAM RATAN SINGH SINPC/DFTMN/0003/2020			