

SITE PLAN

FAR & Tenement Details (Table 4c-1)

Building	No. of Same Bldg	Total Built Up Area (Sq.mt.)	Proposed FAR Area (Sq.mt.) Resi.	Total FAR Area (Sq.mt.)	Total Consumed Additional FAR Area (Sq.mt.)	Tnmt (No.)
A1 (RESIDENSE)	1	269.48	269.48	269.48	269.48	02
Grand Total	1	269.48	269.48	269.48	269.48	02

Proposal Basic Information

Proposal File No.	SINPC/IB/0235/W16/2021
Owner Name	MANJULA TIRKEY
Khata No	59
Plot No	2962
Village Name	Simdega
Use	Residential
SubUse	Bungalow/ Dwelling / Non Apartment

Required Parking (Table 7a)

Building Name	Type	SubUse	Area (Sq.mt.)	Units		Car		Visitors Car		TwoWheeler	
				Reqd.	Prop.	Reqd./Unit	Prop.	Reqd./Unit	Prop.	Reqd./Unit	Prop.
A1 (RESIDENSE)	Residential	Bungalow/ Dwelling / Non Apartment	> 0	1	2.00	1	2	-	-	-	-
			> 0	1	2.00	-	-	1	1	-	-
Total			-	-	-	-	2	2	-	1	2

Parking Check (Table 7b)

Vehicle Type	Reqd.		Prop.	
	No.	Area	No.	Area
Car	-	-	2	25.48
Total Car	2	25.00	2	25.48
Visitor's Car Parking	-	-	2	25.57
Total Visitor Parking	1	12.50	2	25.57
TwoWheeler	-	-	4	30.11
Total TwoWheeler	-	-	4	30.11
Total		37.50		111.27

AREA STATEMENT SIMDEGA NAGAR PANCHAYAT

Region: JHARKHAND URBAN LOCAL BODIES	Plot Use: Residential
District: SIMDEGA	Plot SubUse: Bungalow/ Dwelling / Non Apartment
Authority: SIMDEGA NAGAR PANCHAYAT	PlotNearby/ReligiousStructure: NA
Inward No: SINPC/IB/0235/W16/2021	Plot/SubPlot No: 2962
Application Type: General Proposal	North: -
Project Type: Building Permission	South: -
Nature of Development: New	East: -
Location of Development Area: Old Area	West: -
AREA DETAILS:	SQ.MT.
AREA OF PLOT (Minimum)	(A) 598.88
Deduction for NetPlot Area	
Surrender Free of Cost	21.60
Total	21.60
NET AREA OF PLOT(Gross Plot Area - Deduction from Gross Plot area)	(A-Deductions) 577.28
Deduction for Balance Plot Area(from Gross Plot Area)	
Surrender Free of Cost	21.60
Common Plot	70.32
Total	91.92
BALANCE AREA OF PLOT(Net Plot Area - Recreational/Amenity space)	(A-Deductions) 506.96
PLOT AREA FOR COVERAGE(Net Plot Area)	(A-Deductions) 577.28
Plot Area for FAR (Net Plot Area + Road Widening Area)	(A-Deductions) 598.88
COVERAGE CHECK	
Permissible Coverage area (60.00 %)	346.37
Proposed Coverage Area (23.34 %)	134.74
Total Prop. Coverage Area (23.34 %)	134.74
Balance coverage area (36.66 %)	211.63
FAR CHECK	
Perm. FAR Area (1.50)	898.32
Total Perm. FAR area	898.32
Residential FAR	269.48
Proposed FAR Area	269.48
Total Proposed FAR Area	269.48
Consumed FAR (Factor)	0.45
Balance FAR Area	628.84
BUILT UP AREA CHECK	
Total Proposed BuiltUp Area	269.48
ARCHITECT (Regd)	RAM RATAN SINGH
ENGINEER (Regd)	
SUPERVISOR (Regd)	
OWNER (Regd)	MANJULA TIRKEY
DEVELOPMENT AUTHORITY	LOCAL BODY

COLOR INDEX

PLOT BOUNDARY	Black
ABUTTING ROAD	Green
PROPOSED CONSTRUCTION	Red
COMMON PLOT	Yellow
ROAD WIDENING AREA	Blue
EXISTING (To be retained)	Blue
EXISTING (To be demolished)	Yellow

Buildingwise Floor FAR Details

Floor Name	Building Name A1 (RESIDENSE)		Total	
	Proposed Built Up Area (Sq.mt.)	Proposed FAR Area (Sq.mt.)	Total Proposed Built Up Area (Sq.mt.)	Total FAR Area (Sq.mt.)
Ground Floor	134.74	134.74	134.74	134.74
First Floor	134.74	134.74	134.74	134.74
Terrace Floor	0.00	0.00	0.00	0.00
Total	269.48	269.48	269.48	269.48

Building USE/SUBUSE Details

Building Name	Building Use	Building SubUse	Building Structure
A1 (RESIDENSE)	Residential	Bungalow/ Dwelling / Non Apartment	Non-Highrise

LTP NAME AND SIGNATURE	STRUCTURAL ENG'S NAME AND SIGNATURE	BUILDER NAME AND SIGNATURE	DIGITAL SIGNATURE
RAM RATAN SINGH SINPC/DFTMN/0003/2020			

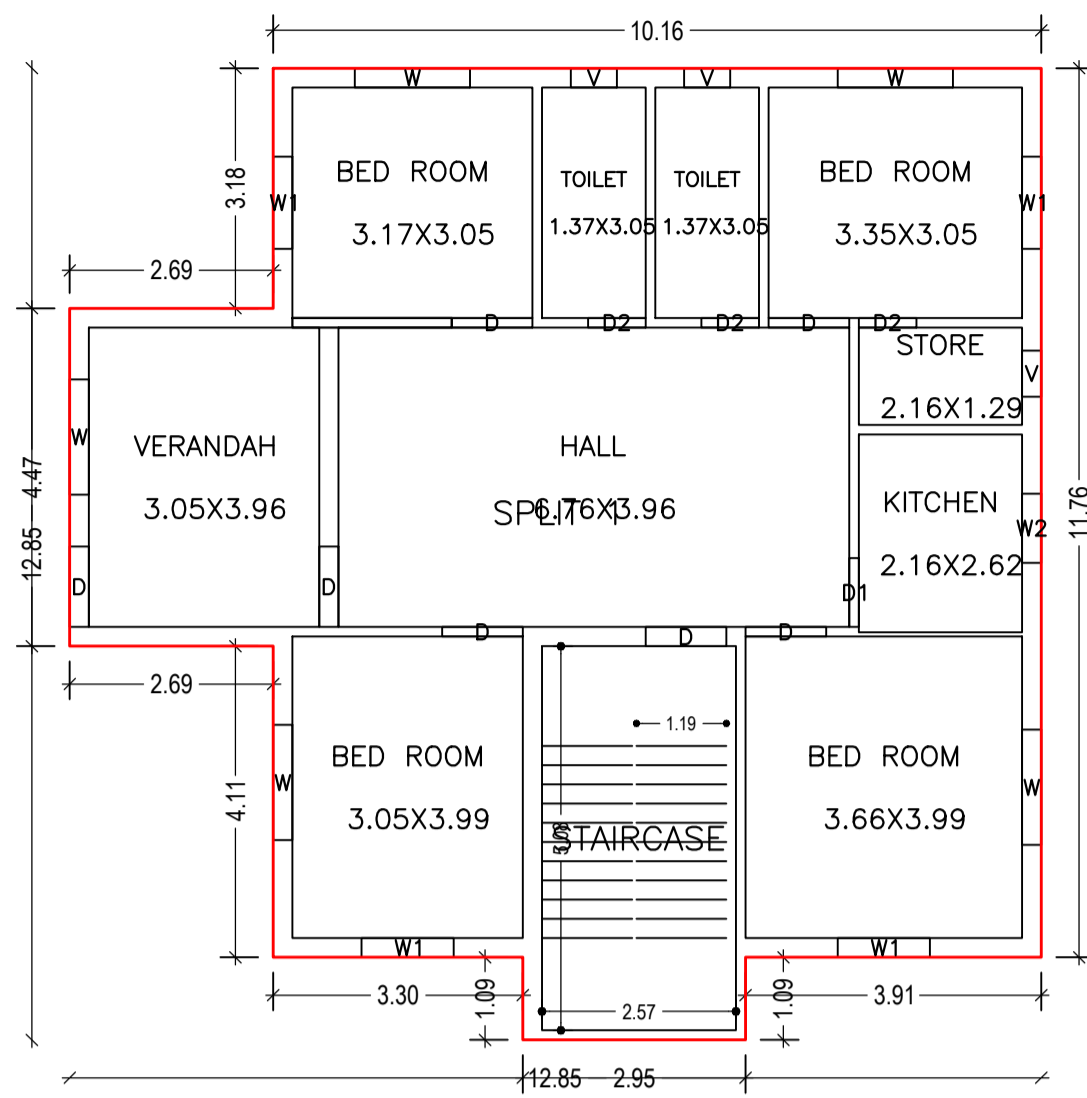

GROUND FLOOR PLAN (Proposed) (SCALE 1:100)

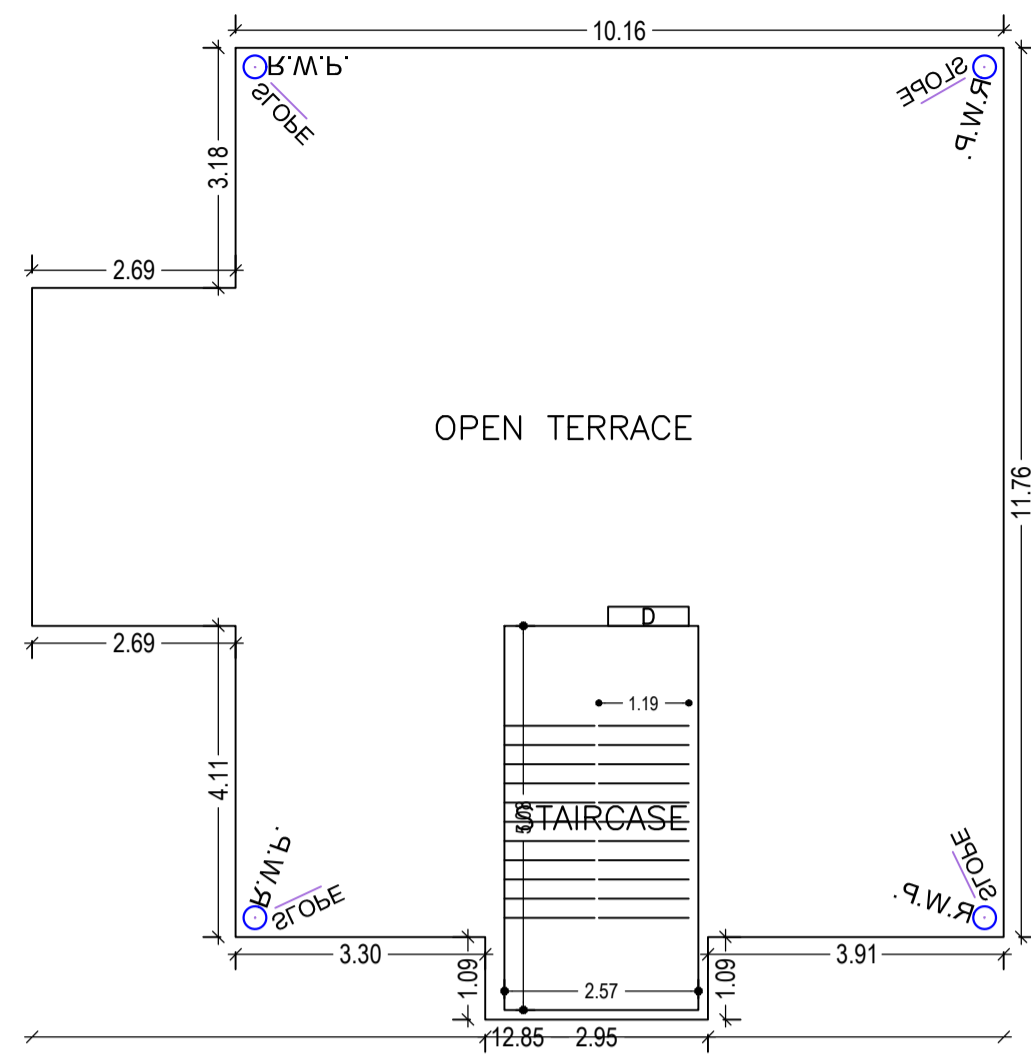

TERRACE FLOOR PLAN (SCALE 1:100)

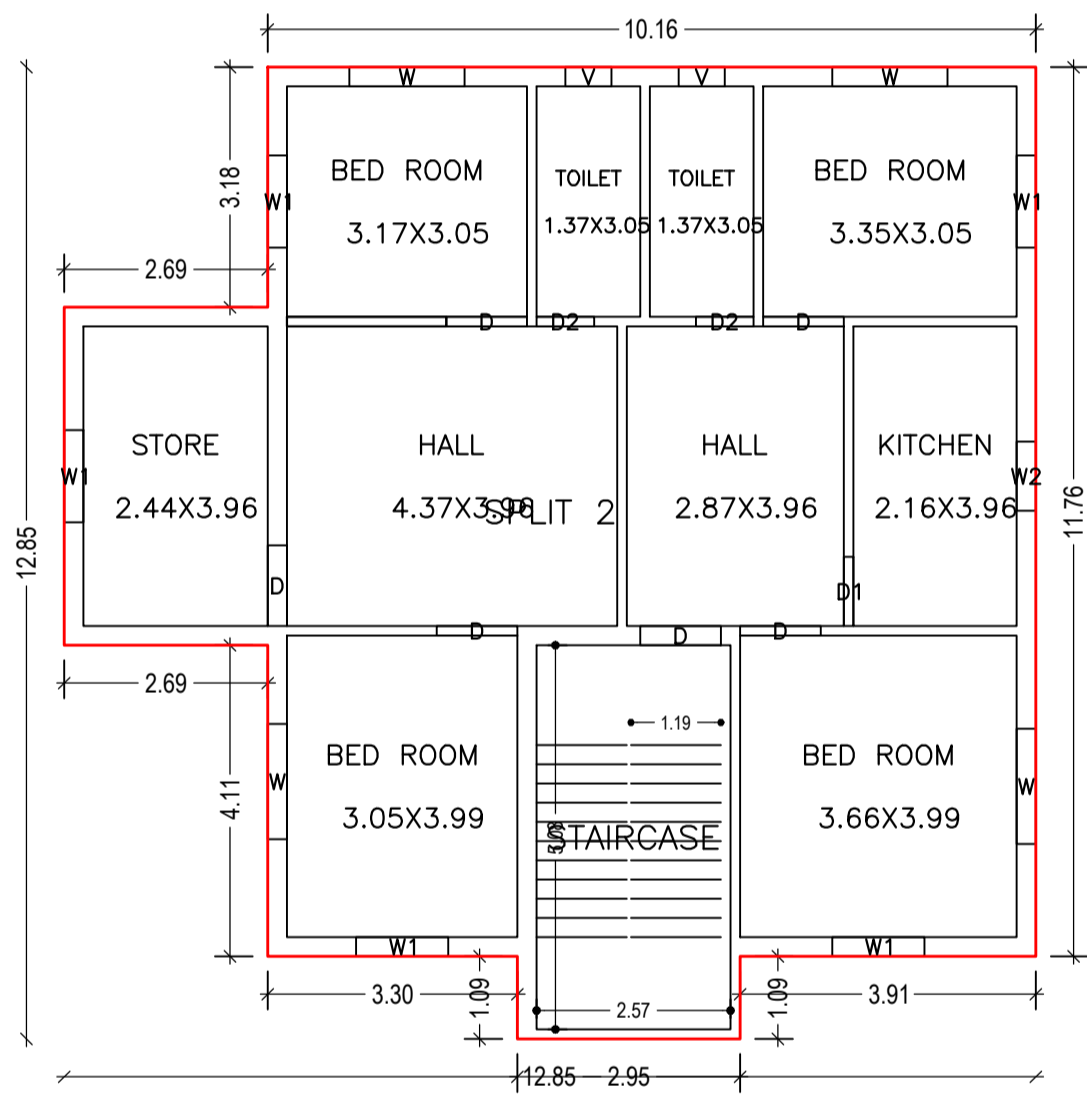

FIRST FLOOR PLAN (Proposed) (SCALE 1:100)

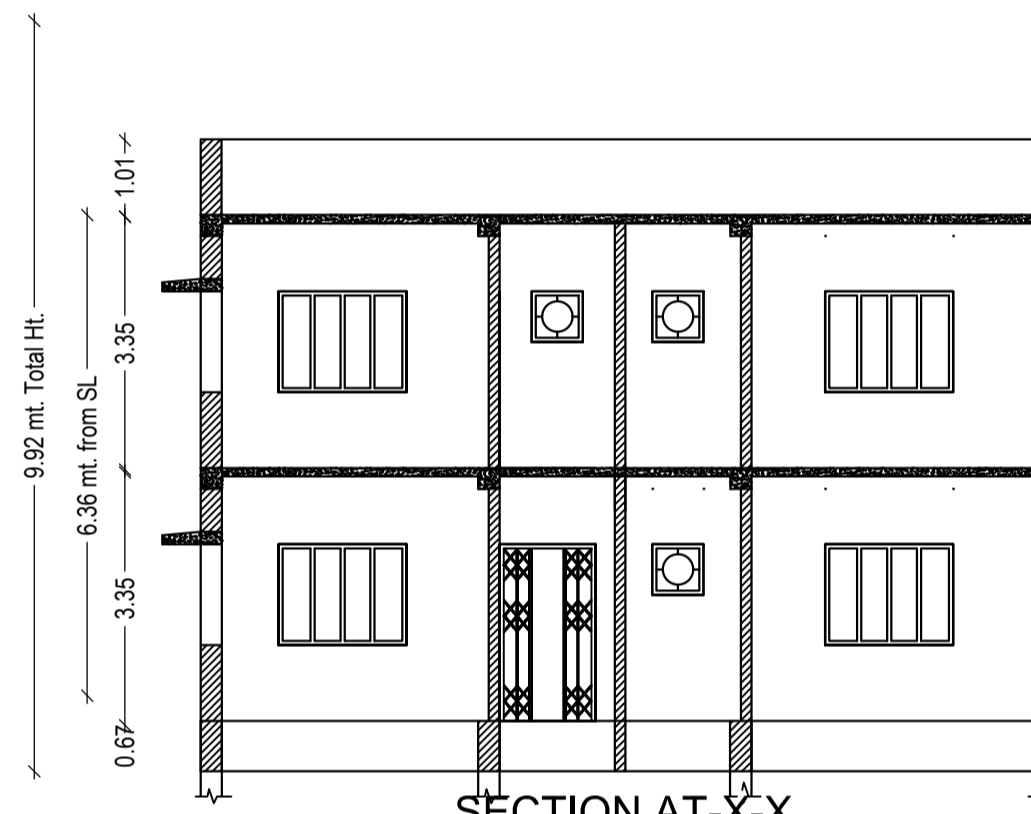

SECTION AT-X-X (SCALE 1:100)

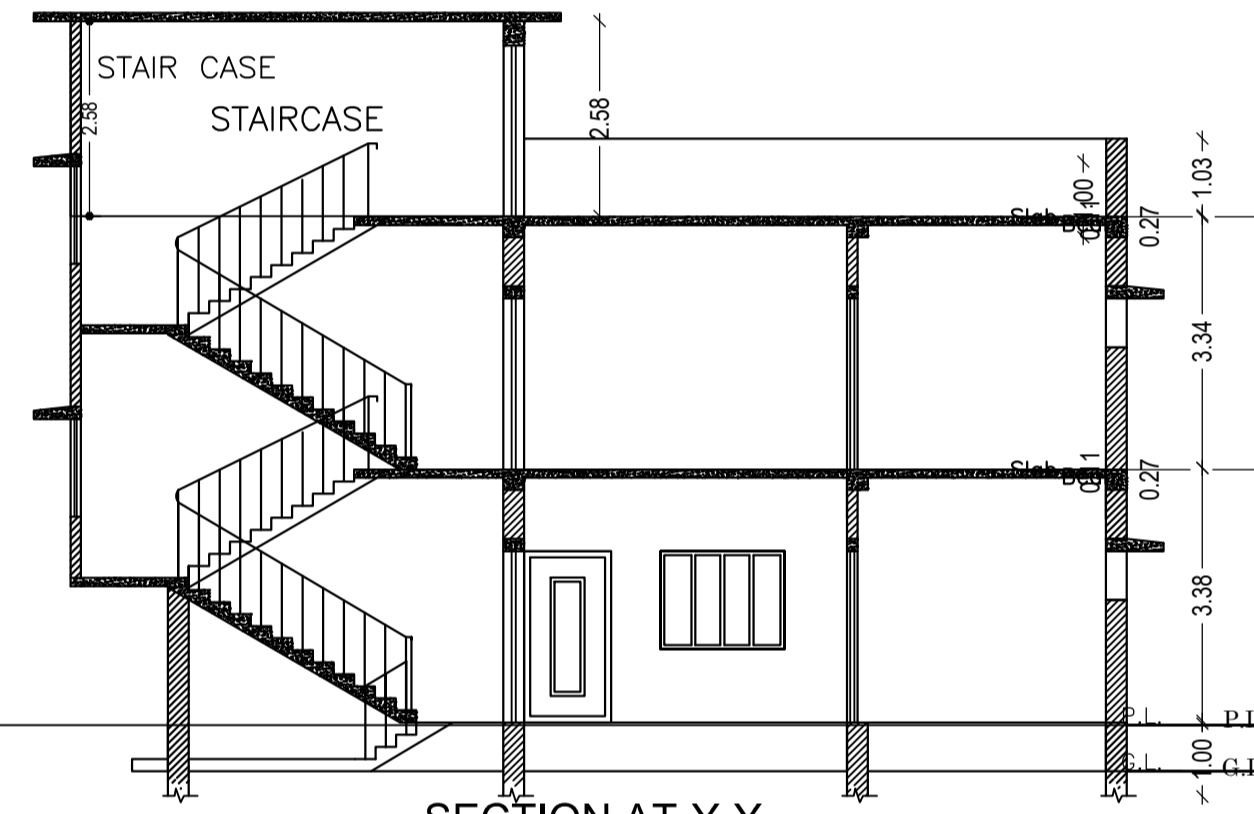

SECTION AT-Y-Y (SCALE 1:100)

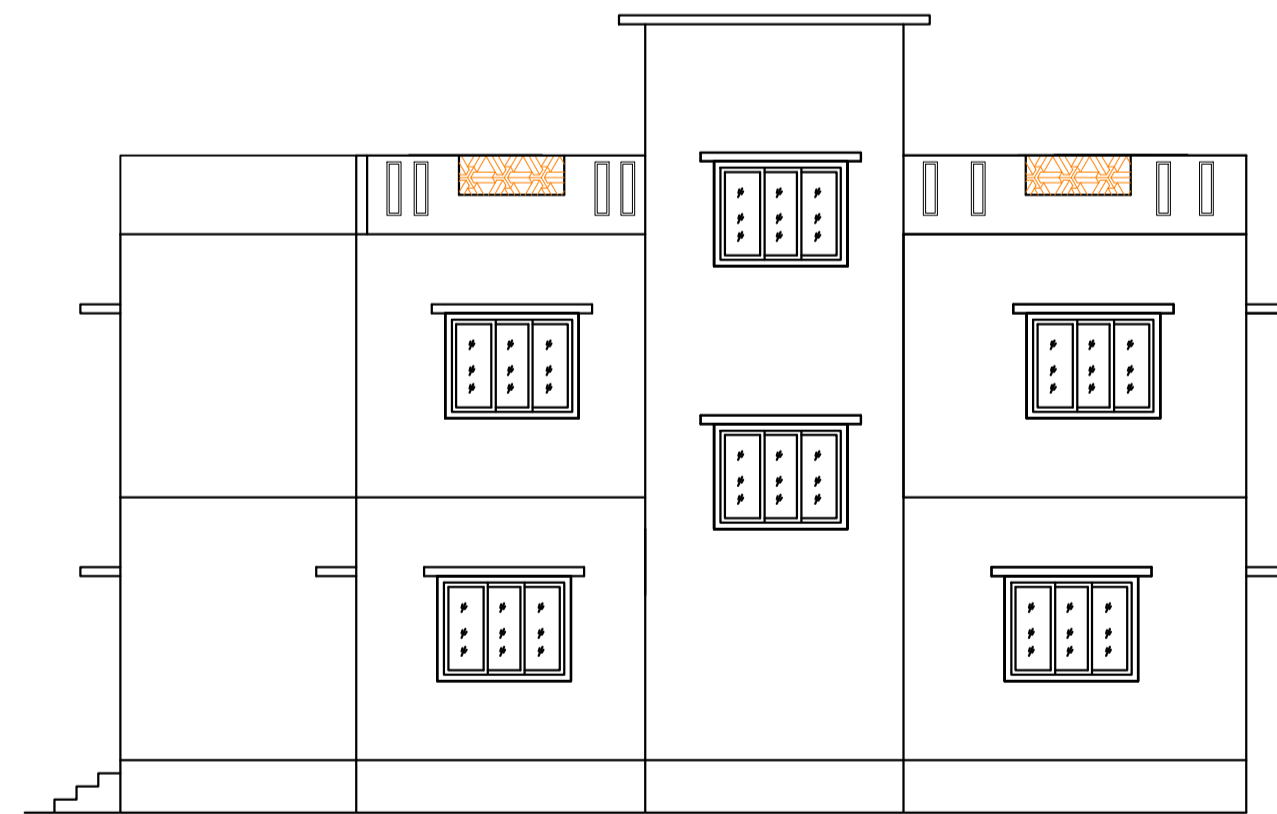

FRONT ELEVATION (SCALE 1:100)



LEFT SIDE ELEVATION (SCALE 1:100)

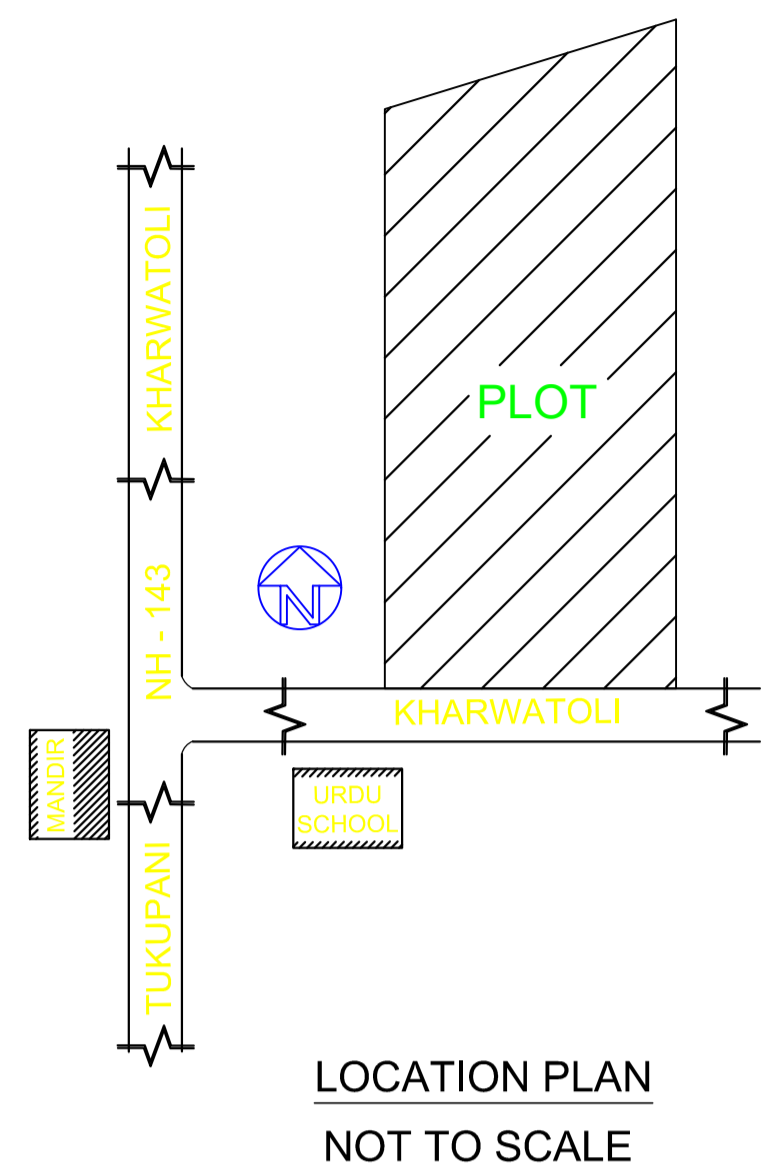

LOCATION PLAN (NOT TO SCALE)

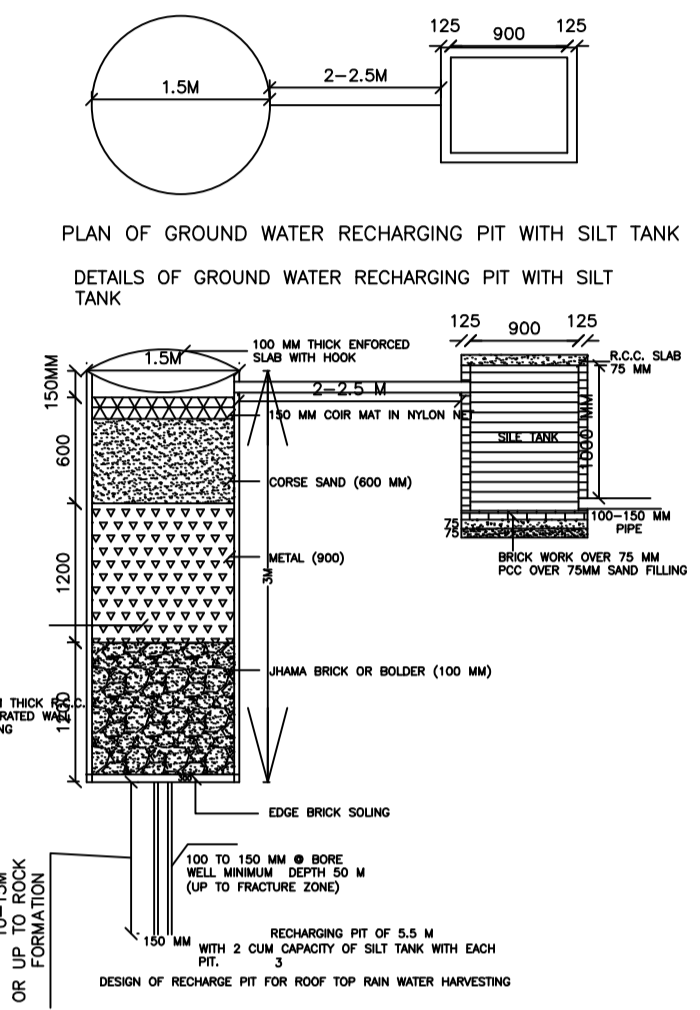

PLAN OF GROUND WATER RECHARGING PIT WITH SILT TANK
DETAILS OF GROUND WATER RECHARGING PIT WITH SILT TANK

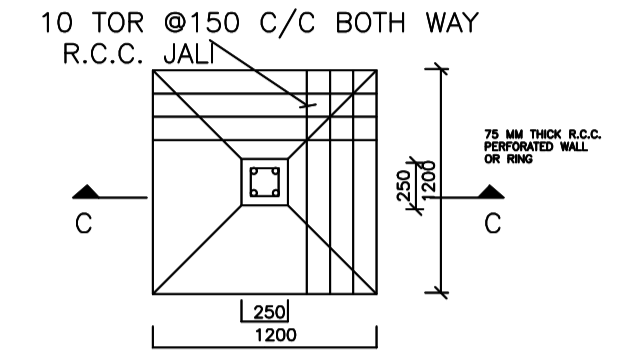

DETAIL OF FOUNDATION (SCALE: 1:50)
SECTION -CC

Floor Name	Total Built Up Area (Sq.mt.)	Proposed FAR Area (Sq.mt.)	Total FAR Area (Sq.mt.)	Total Consumed Additional FAR Area (Sq.mt.)	Tnmt (No.)
Ground Floor	134.74	134.74	134.74	134.74	01
First Floor	134.74	134.74	134.74	134.74	01
Terrace Floor	0.00	0.00	0.00	0.00	00
Total:	269.48	269.48	269.48	269.48	02
Total Number of Same Buildings	1				
Total:	269.48	269.48	269.48	269.48	02

SCHEDULE OF DOOR:

BUILDING NAME	NAME	LENGTH	HEIGHT	NOS
A1 (RESIDENSE)	D2	0.76	2.10	05
A1 (RESIDENSE)	D1	0.91	2.10	02
A1 (RESIDENSE)	D	1.07	2.10	13

SCHEDULE OF WINDOW/VENTILATION:

BUILDING NAME	NAME	LENGTH	HEIGHT	NOS
A1 (RESIDENSE)	V	0.61	1.20	05
A1 (RESIDENSE)	W2	0.91	1.20	02
A1 (RESIDENSE)	W1	1.22	1.20	09
A1 (RESIDENSE)	W	1.52	1.20	09

UnitBUA Table for Building :A1 (RESIDENSE)

FLOOR	Name	UnitBUA Type	UnitBUA Area	Carpet Area	No. of Rooms	No. of Tenement
FIRST FLOOR	SPLIT 2	FLAT	107.15	106.88	10	1
GROUND FLOOR	SPLIT 1	FLAT	107.15	106.88	10	1
Total:	-	-	214.30	213.76	20	2

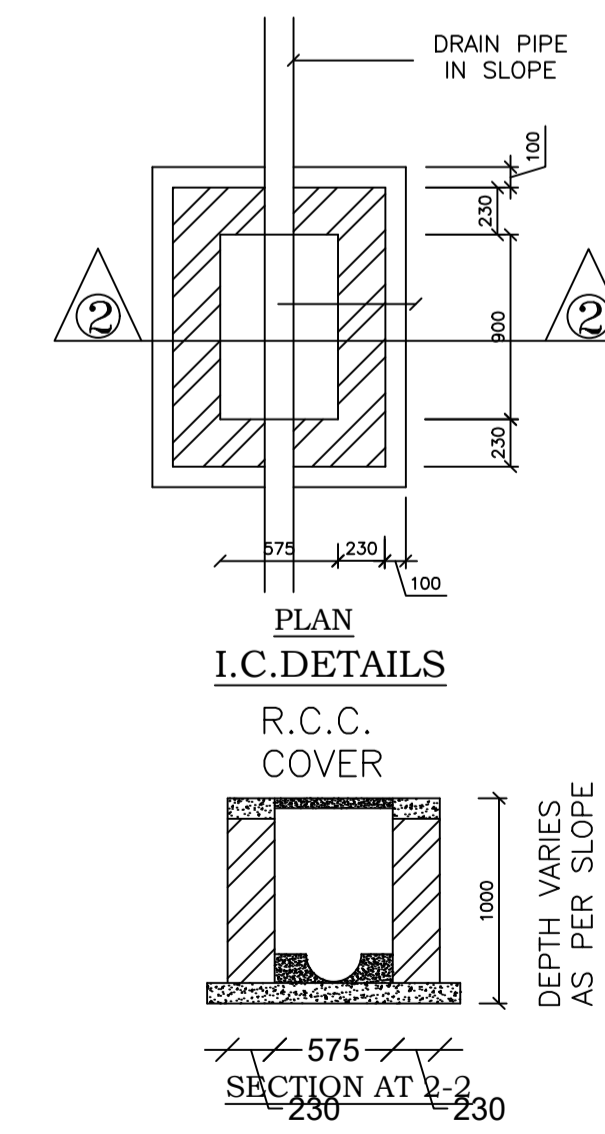

PLAN I.C. DETAILS (SCALE 1:50)
SECTION AT 2-2

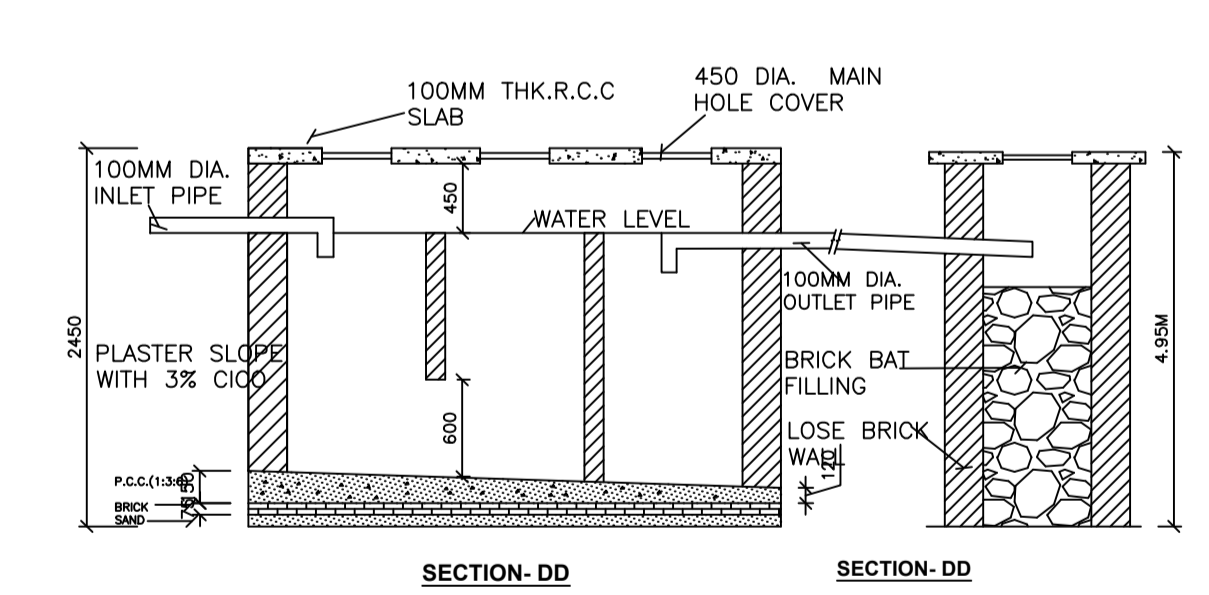

SECTION-DD (SCALE 1:50)
DETAIL OF SEPTIC TANK & SOAKPIT.

LTP NAME AND SIGNATURE	STRUCTURAL ENG'S NAME AND SIGNATURE	BUILDER NAME AND SIGNATURE	DIGITAL SIGNATURE
RAM RATAN SINGH SINPC/DFTMN/0003/2020			

Proposal Basic Information	
Proposal File No.	SINPC/BP/0235/W16/2021
Owner Name	MANJULA TIRKEY
Khata No	59
Plot No	2962
Village Name	Simdega
Use	Residential
SubUse	Bungalow/ Dwelling / Non Apartment

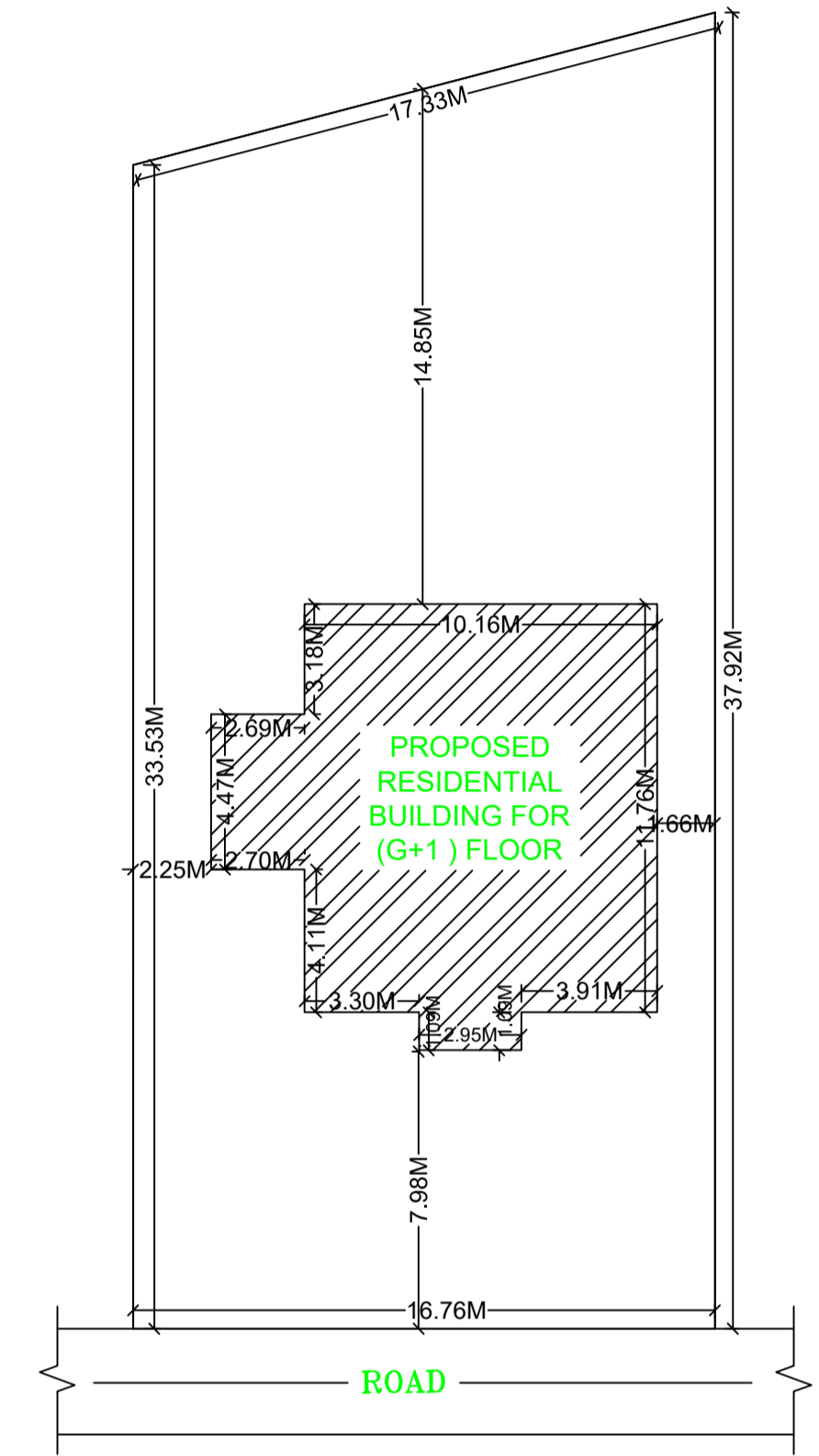

KEY PLAN
SCALE 1:200

LTP NAME AND SIGNATURE	STRUCTURAL ENG'S NAME AND SIGNATURE	BUILDER NAME AND SIGNATURE	DIGITAL SIGNATURE
RAM RATAN SINGH SINPC/DFTMN/0003/2020			