

SITE PLAN

FAR & Tenement Details (Table 4c-1)

Building	No. of Same Bldg	Total Built Up Area (Sq.mt.)	Proposed FAR Area (Sq.mt.) Resi.	Total FAR Area (Sq.mt.)	Total Consumed Additional FAR Area (Sq.mt.)	Tnmt (No.)
A (SMT ANANDIT BARA)	1	303.60	303.60	303.60	303.60	01
Grand Total :	1	303.60	303.60	303.60	303.60	01

Proposal Basic Information

Proposal File No.	SINPC/BP/0245/W02/2021
Owner Name	ANANDIT BARA
Khata No	262
Plot No	5042
Village Name	Gotra
Use	Residential
SubUse	Bungalow/ Dwelling / Non Apartment

AREA STATEMENT SIMDEGA NAGAR PANCHAYAT		VERSION NO. : 1.0.60
PROJECT DETAIL:		VERSION DATE: 16/10/2020
Region: JHARKHAND URBAN LOCAL BODIES	Plot Use: Residential	
District: SIMDEGA	Plot SubUse: Bungalow/ Dwelling / Non Apartment	
Authority: SIMDEGA NAGAR PANCHAYAT	PlotNearbyReligiousStructure: NA	
Inward No: SINPC/BP/0245/W02/2021	PlotSubPlot No: 5042	
Application Type: General Proposal	North: -	
Project Type: Building Permission	South: -	
Nature of Development: New	East: -	
Location of Development Area: Old Area	West: -	
AREA DETAILS:		
AREA OF PLOT (Minimum)	(A)	SQ.MT. 730.62
Deduction for NetPlot Area		
Surrender Free of Cost		29.70
Total		29.70
NET AREA OF PLOT(Gross Plot Area - Deduction from Gross Plot area)		
(A-Deductions)		700.92
Deduction for Balance Plot Area(from Gross Plot Area)		
Surrender Free of Cost		29.70
Common Plot		123.59
Total		153.29
BALANCE AREA OF PLOT(Net Plot Area - Recreational/Amenity space)		
(A-Deductions)		577.33
PLOT AREA FOR COVERAGE(Net Plot Area)		
(A-Deductions)		700.92
Plot Area for FAR (Net Plot Area + RoadWidening Area)		
(A-Deductions)		730.62
COVERAGE CHECK		
Permissible Coverage area (60.00 %)		420.55
Proposed Coverage Area (14.44 %)		101.20
Total Prop. Coverage Area (14.44 %)		101.20
Balance coverage area (45.56 %)		319.35
FAR CHECK		
Perm. FAR Area (1.50)		1095.93
Total Perm. FAR area		1095.93
Residential FAR		303.59
Proposed FAR Area		303.59
Total Proposed FAR Area		303.59
Consumed FAR (Factor)		0.42
Balance FAR Area		792.34
BUILT UP AREA CHECK		
Total Proposed BuiltUp Area		303.60
ARCHITECT (Regd)	MD RAGIB SAYEED	
ENGINEER (Regd)		
SUPERVISOR (Regd)		
OWNER (Regd)	ANANDIT BARA	
DEVELOPMENT AUTHORITY		LOCAL BODY

COLOR INDEX	
PLOT BOUNDARY	Black
ABUTTING ROAD	Green
PROPOSED CONSTRUCTION	Red
COMMON PLOT	Yellow
ROAD WIDENING AREA	Blue
EXISTING (To be retained)	Orange
EXISTING (To be demolished)	Light Blue

Buildingwise Floor FAR Details

Floor Name	Building Name		Total	
	Proposed Built Up Area (Sq.mt.)	Proposed FAR Area (Sq.mt.)	Total Proposed Built Up Area (Sq.mt.)	Total FAR Area (Sq.mt.)
Ground Floor	101.20	101.20	101.20	101.20
First Floor	101.20	101.20	101.20	101.20
Second Floor	101.20	101.20	101.20	101.20
Terrace Floor	0.00	0.00	0.00	0.00
Total :	303.60	303.60	303.60	303.60

Building USE/SUBUSE Details

Building Name	Building Use	Building SubUse	Building Structure
A (SMT ANANDIT BARA)	Residential	Bungalow/ Dwelling / Non Apartment	Non-Highrise

LTP NAME AND SIGNATURE	STRUCTURAL ENG'S NAME AND SIGNATURE	BUILDER NAME AND SIGNATURE	DIGITAL SIGNATURE
MD RAGIB SAYEED SINPC/ENG/0001/2017			

Proposal Basic Information	
Proposal File No.	SINPC/BP/0245/W02/2021
Owner Name	ANANDIT BARA
Khata No	262
Plot No	5042
Village Name	Gotra
Use	Residential
SubUse	Bungalow/ Dwelling / Non Apartment

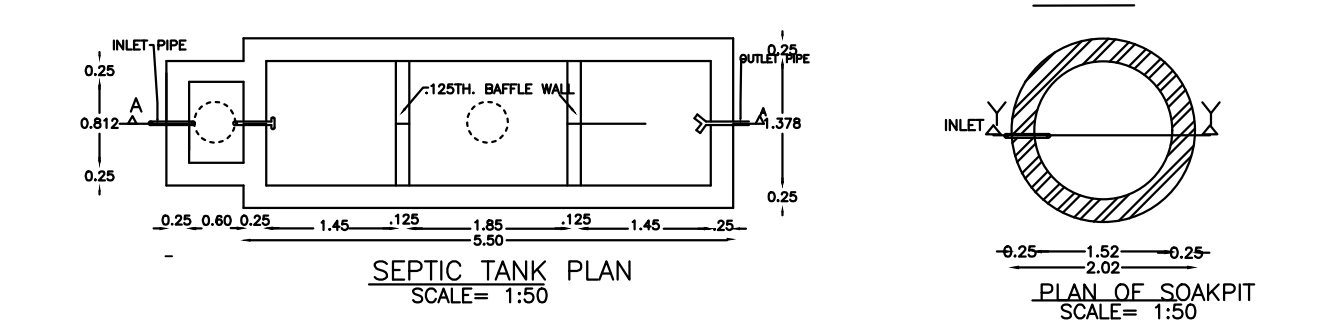
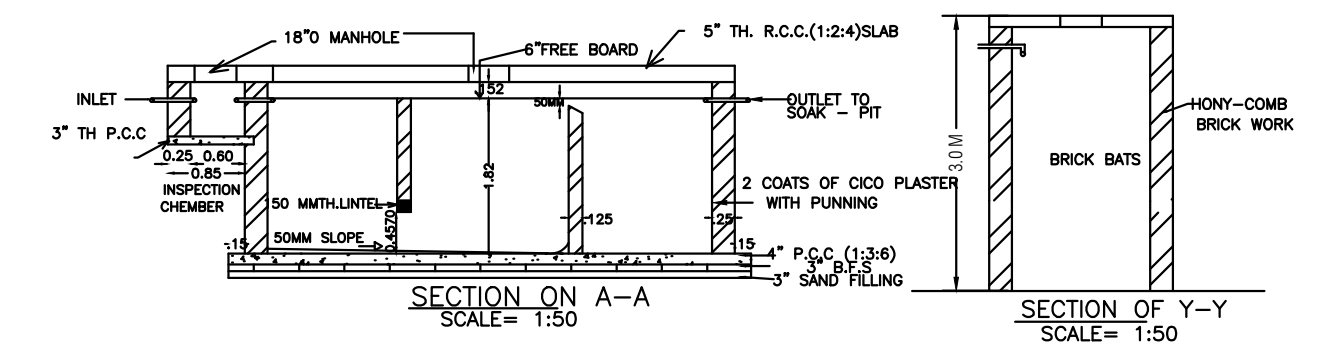
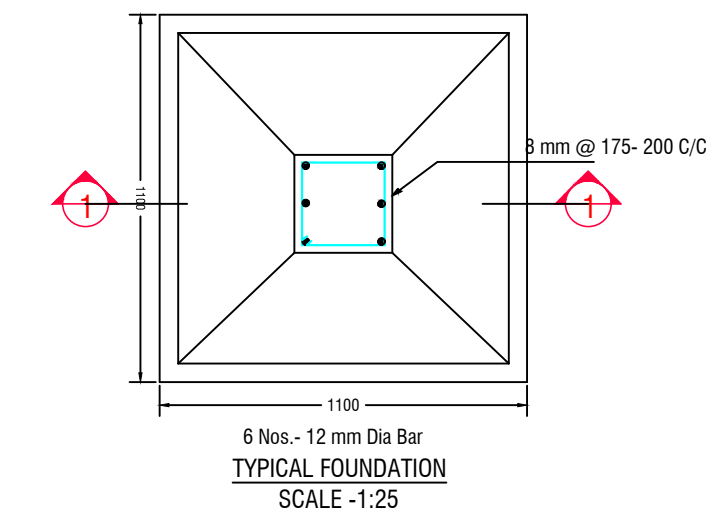
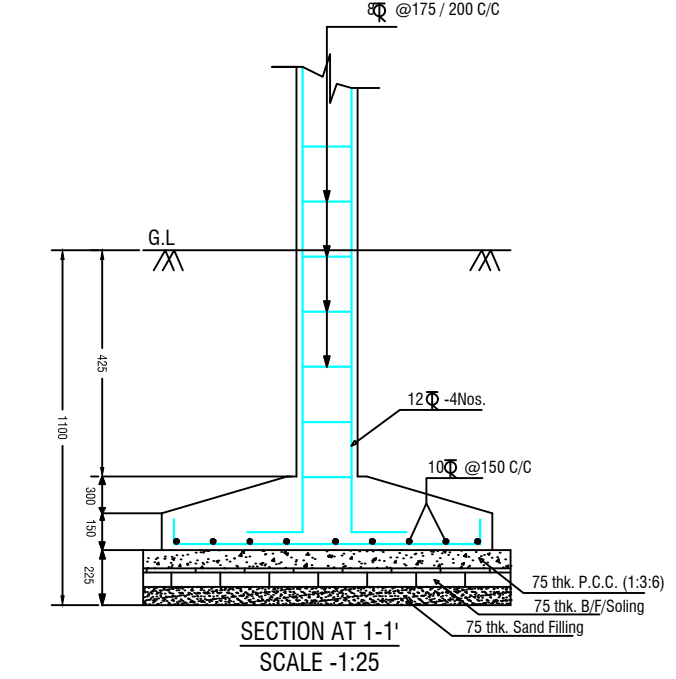
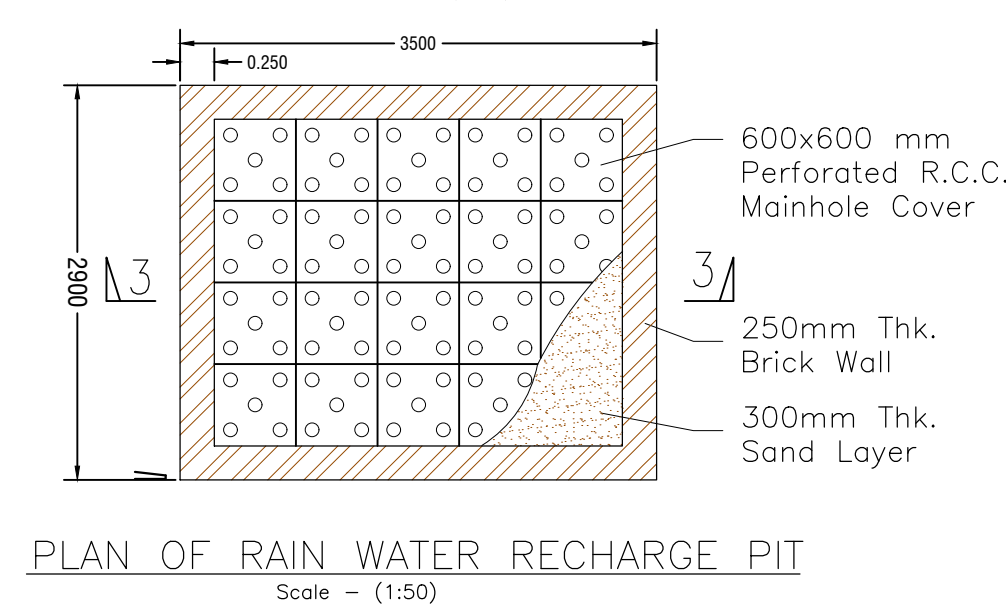
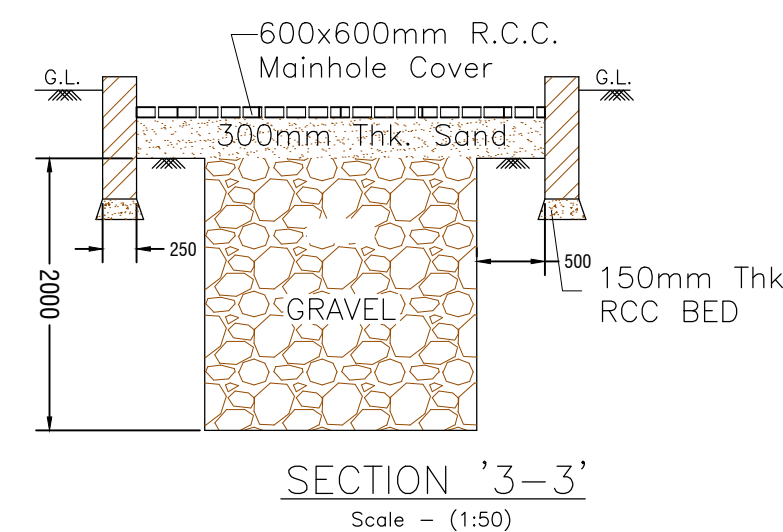
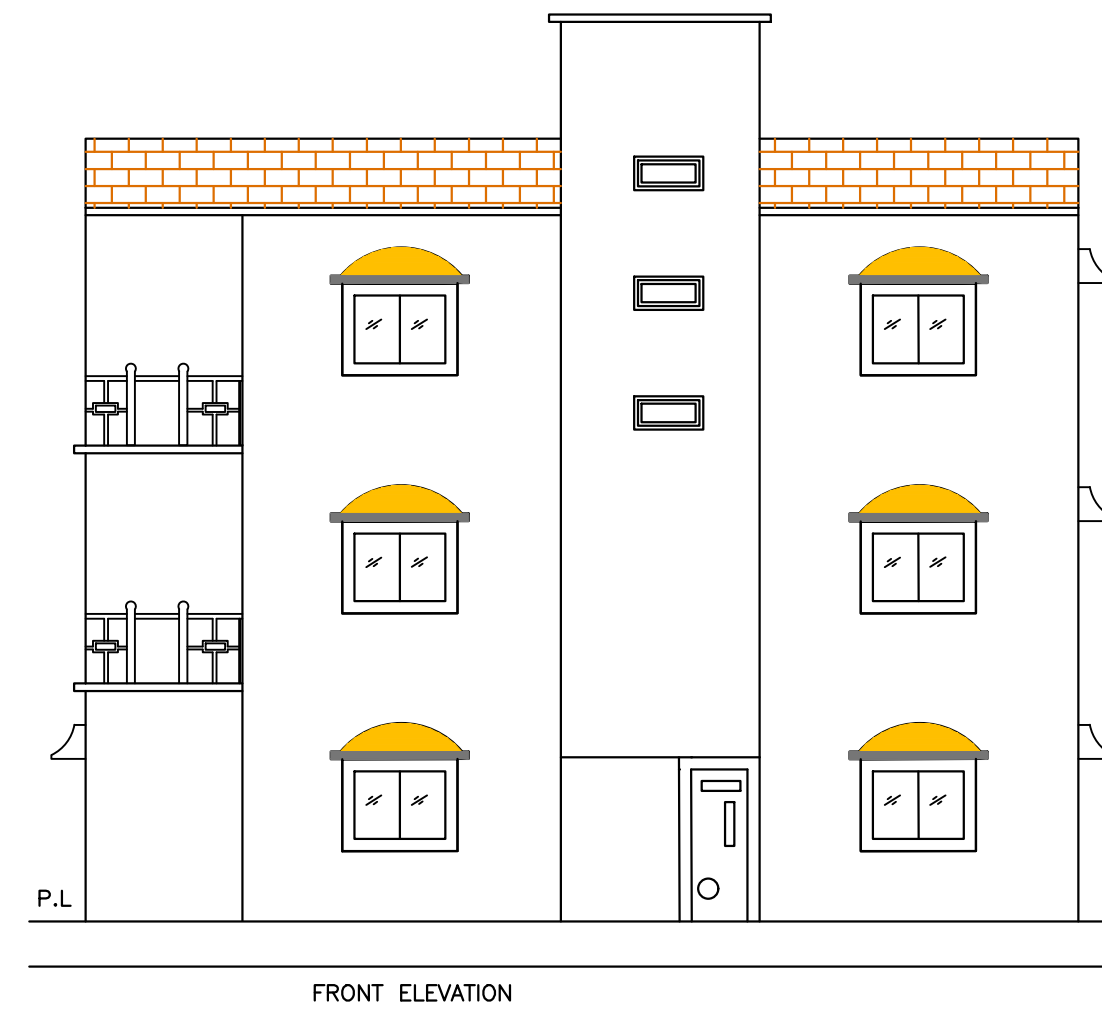
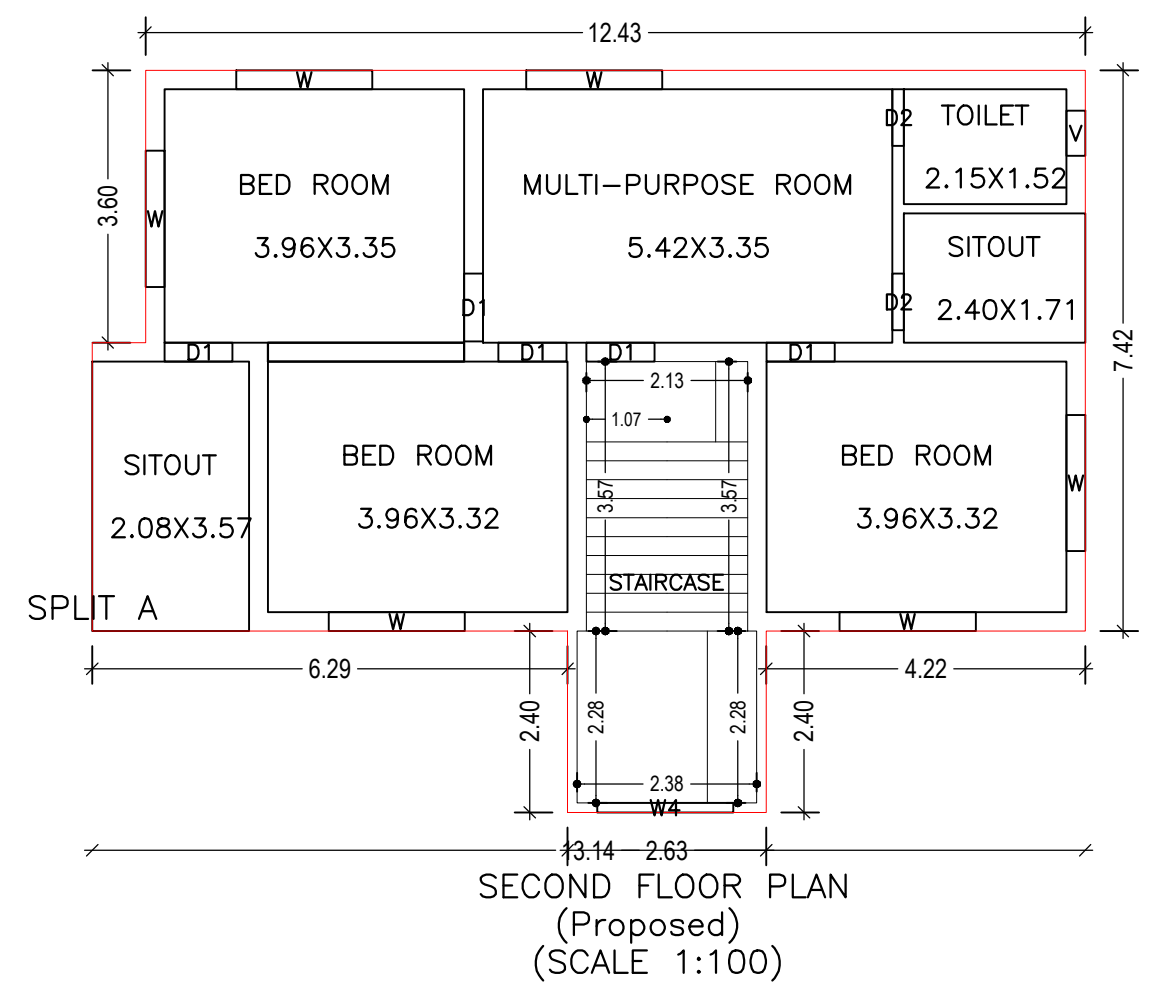
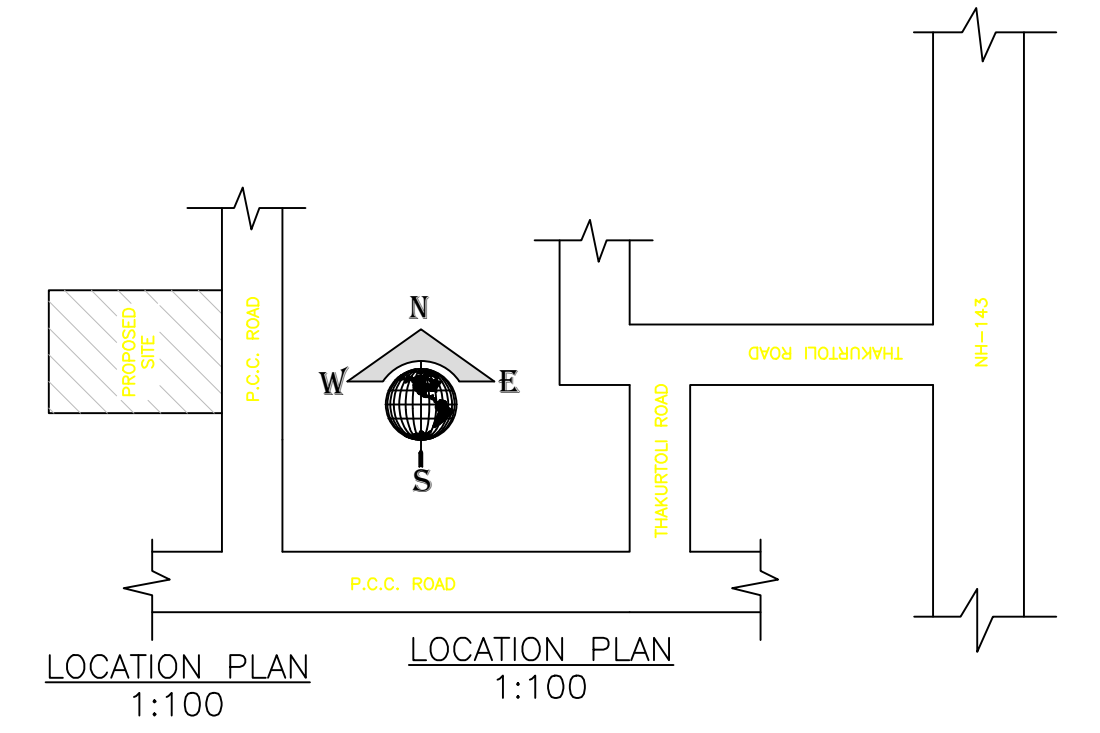
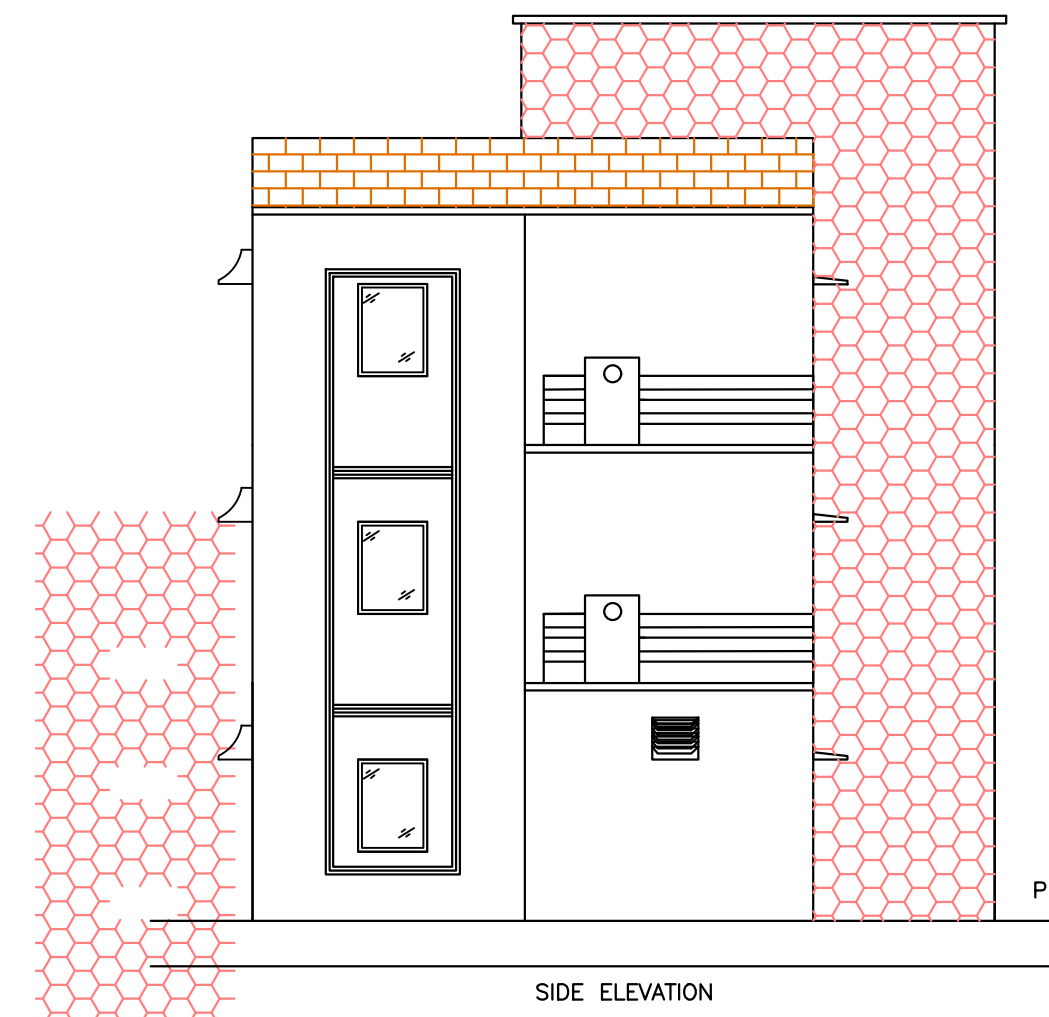
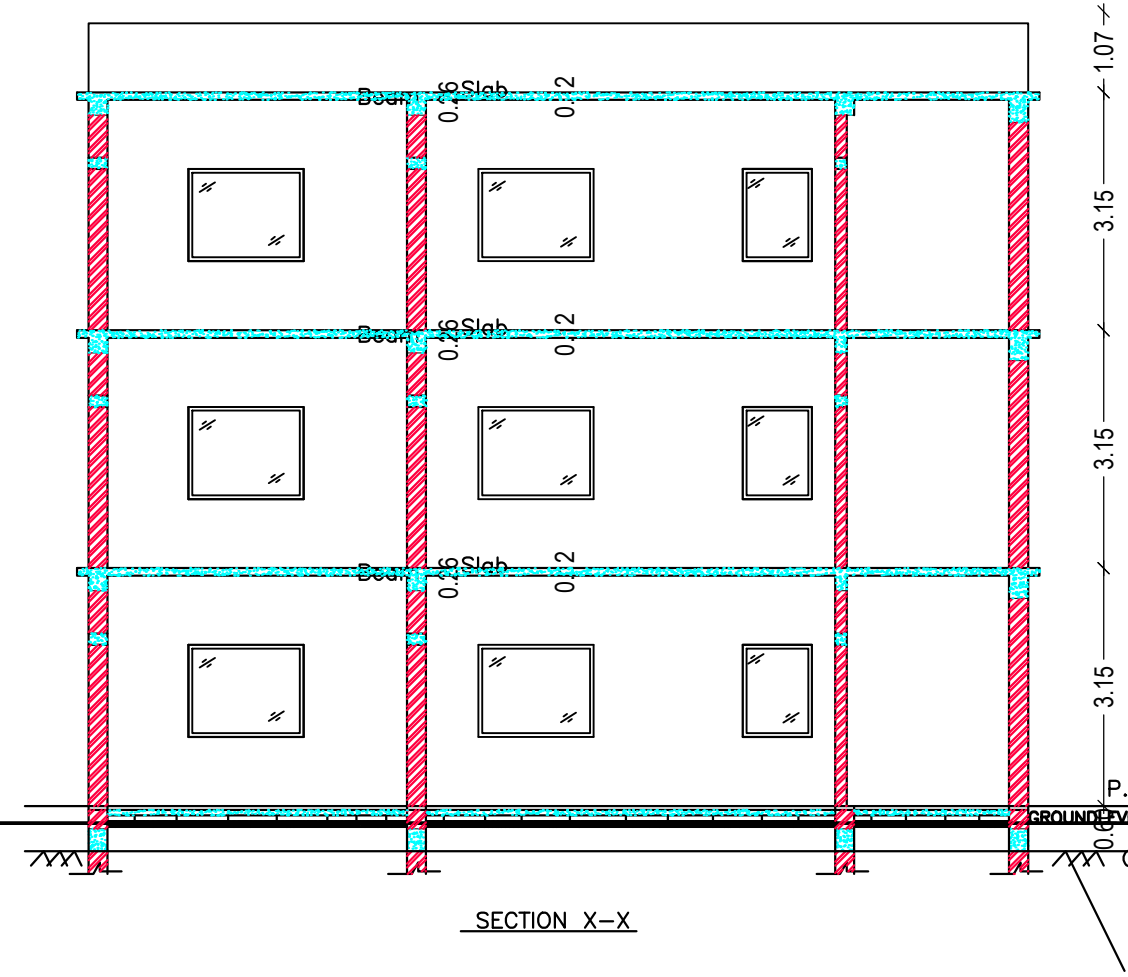
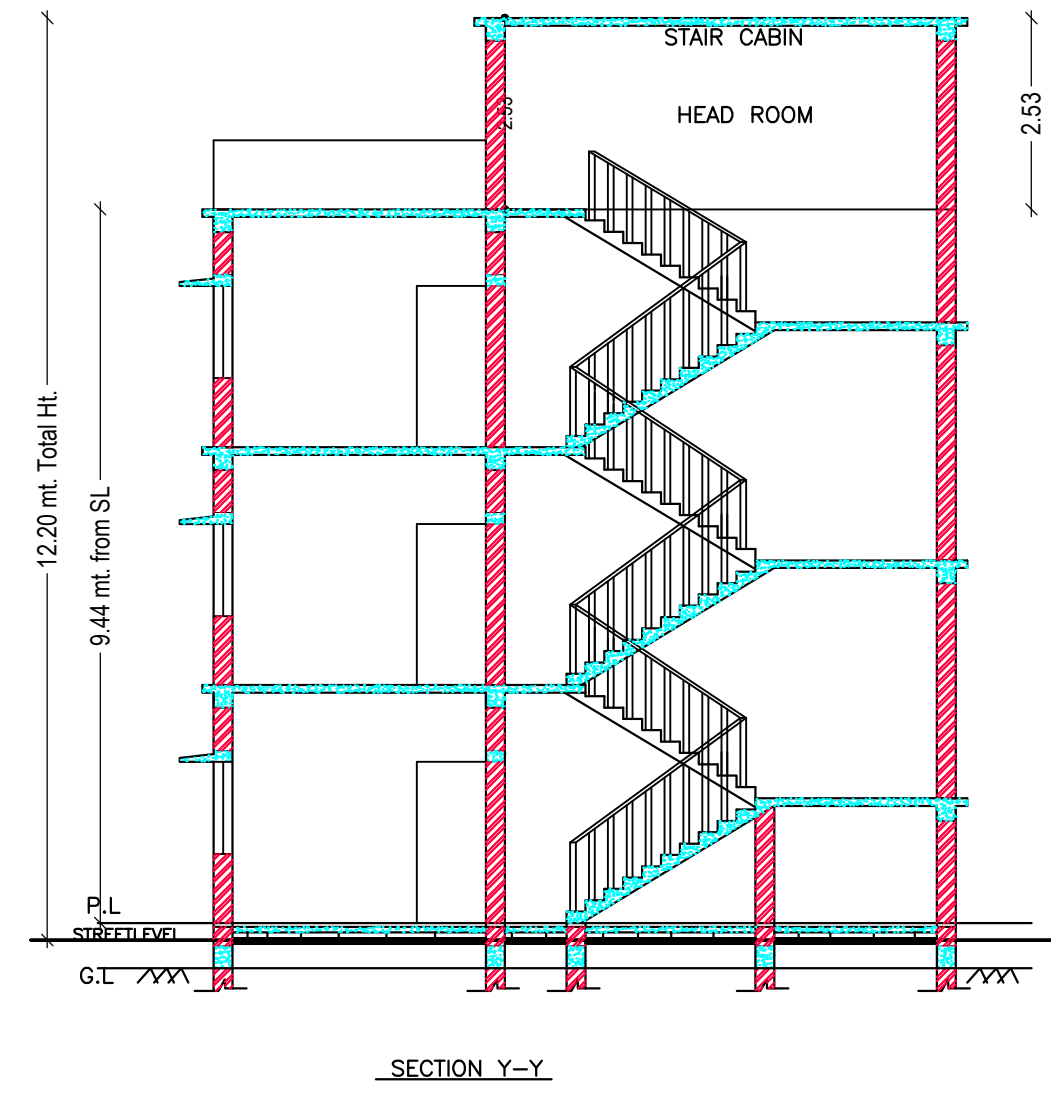
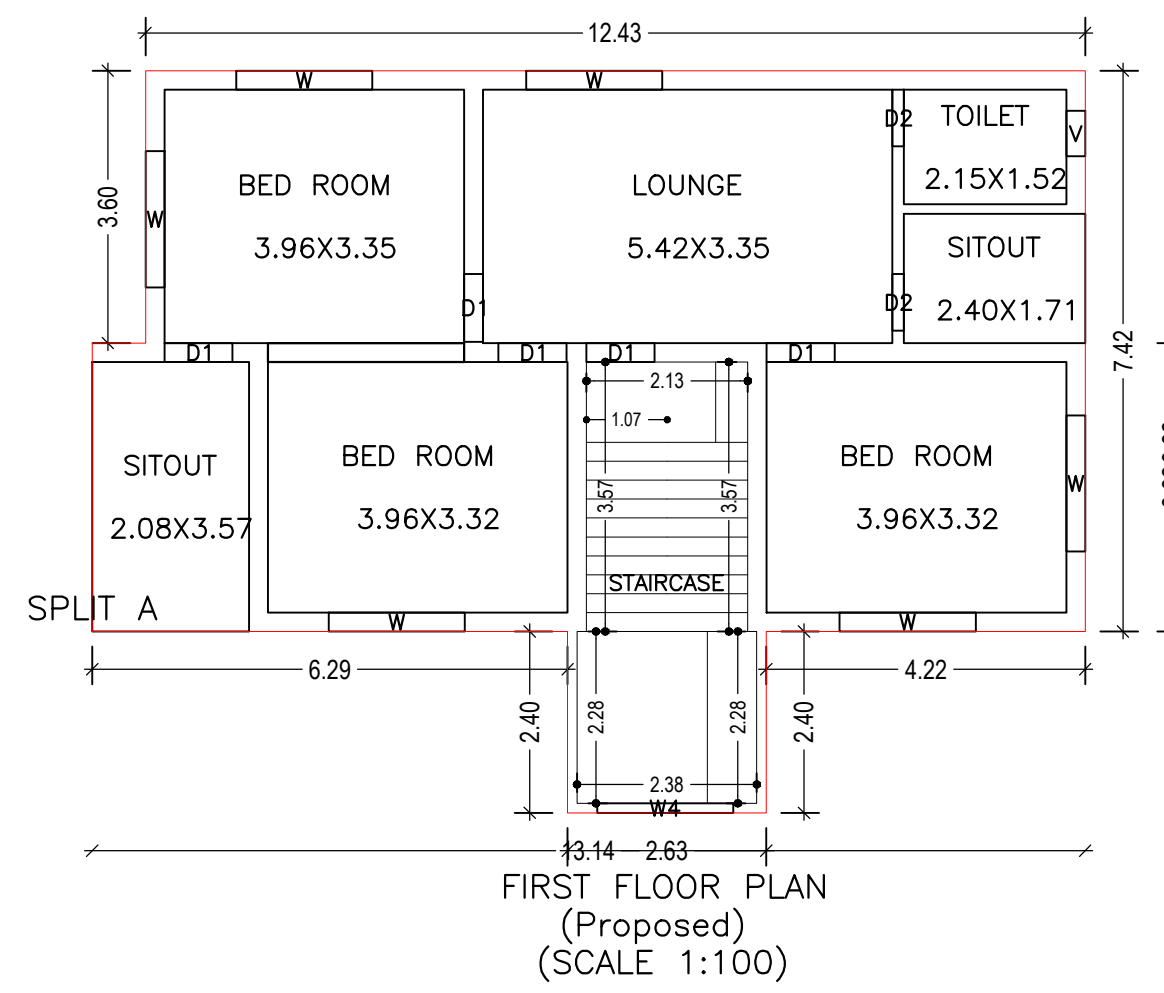
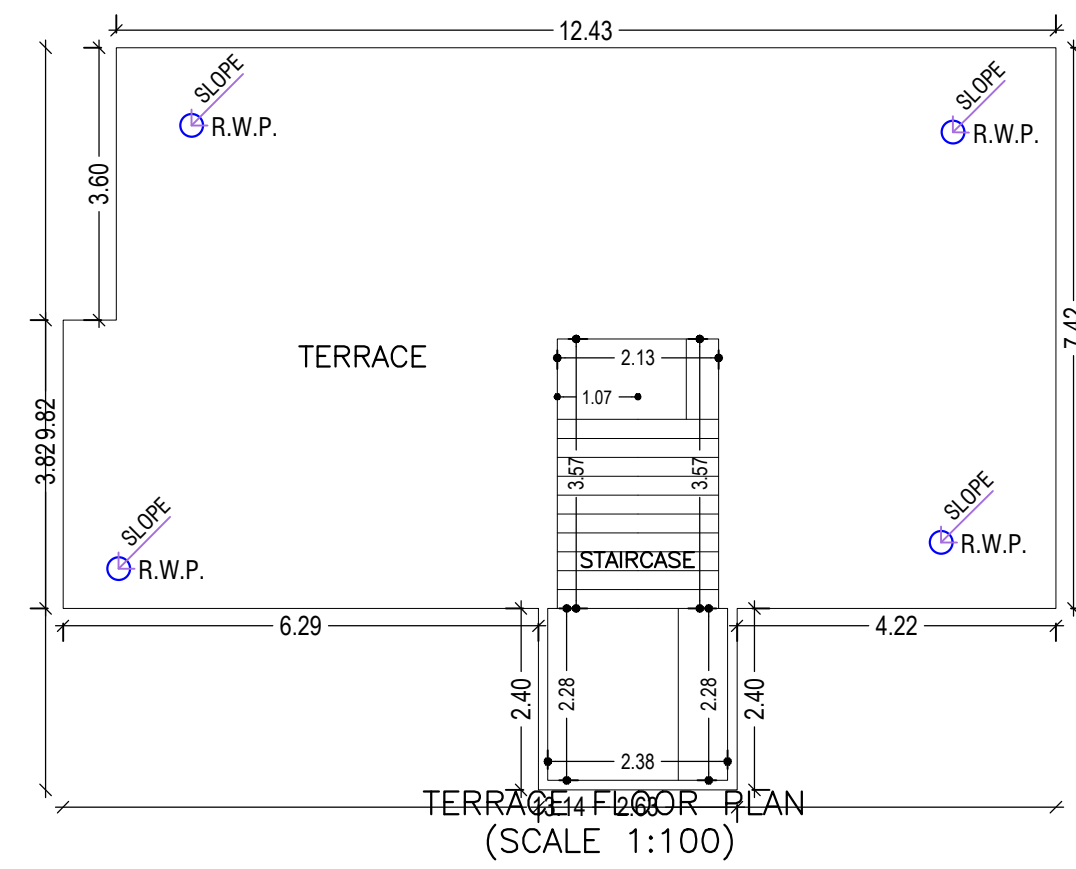
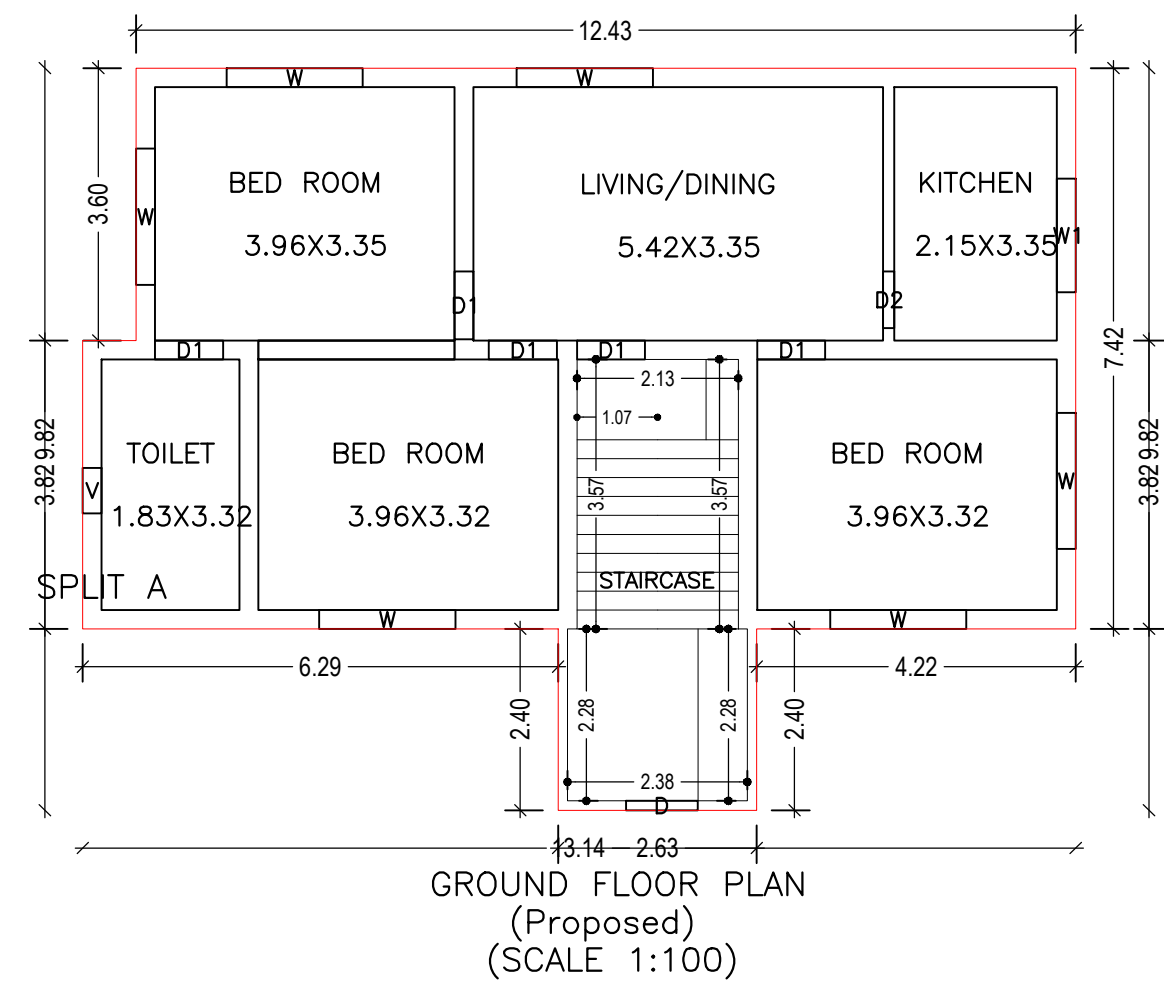

SCHEDULE OF DOOR:

BUILDING NAME	NAME	LENGTH	HEIGHT	NOS
A (SMT ANANDIT BARA)	D2	0.75	2.13	05
A (SMT ANANDIT BARA)	D1	0.90	2.13	15

SCHEDULE OF WINDOW/VENTILATION:

BUILDING NAME	NAME	LENGTH	HEIGHT	NOS
A (SMT ANANDIT BARA)	V	0.60	2.70	03
A (SMT ANANDIT BARA)	W1	1.50	2.70	01
A (SMT ANANDIT BARA)	W	1.80	2.70	18
A (SMT ANANDIT BARA)	W4	1.80	2.70	02

UnitBUA Table for Building :A (SMT ANANDIT BARA)

FLOOR	Name	UnitBUA Type	UnitBUA Area	Carpet Area	No. of Rooms	No. of Tenement
GROUND FLOOR PLAN	SPLIT A	FLAT	229.97	228.03	6	1
FIRST FLOOR PLAN	SPLIT A	FLAT	0.00	0.00	7	0
SECOND FLOOR PLAN	SPLIT A	FLAT	0.00	0.00	7	0
Total:	-	-	229.97	228.03	20	1

Building :A (SMT ANANDIT BARA)

Floor Name	Total Built Up Area (Sq.mt.)	Proposed FAR Area (Sq.mt.)	Total FAR Area (Sq.mt.)	Total Consumed Additional FAR Area (Sq.mt.)	Tnmt (No.)
Ground Floor	101.20	101.20	101.20	101.20	01
First Floor	101.20	101.20	101.20	101.20	00
Second Floor	101.20	101.20	101.20	101.20	00
Terrace Floor	0.00	0.00	0.00	0.00	00
Total:	303.60	303.60	303.60	303.60	01
Total Number of Same Buildings	1				
Total:	303.60	303.60	303.60	303.60	01

LTP NAME AND SIGNATURE	STRUCTURAL ENG'S NAME AND SIGNATURE	BUILDER NAME AND SIGNATURE	DIGITAL SIGNATURE
MD RAGIB SAYEED SINPC/ENG/0001/2017			