

SITE PLAN

FAR & Tenement Details (Table 4c-1)

Building	No. of Same Bldg	Total Built Up Area (Sq.mt.)	Proposed FAR Area (Sq.mt.) Resi.	Total FAR Area (Sq.mt.)	Total Consumed Additional FAR Area (Sq.mt.)	Tnmt (No.)
A1 (RESICOMM BLDG)	1	127.92	85.28	127.92	127.92	03
Grand Total :	1	127.92	85.28	127.92	127.92	03

Proposal Basic Information

Proposal File No.	SINPC/BP/0250/W05/2021
Owner Name	AJIT KUMAR
Khata No	12
Plot No	5083
Village Name	Gotra
Use	Residential
SubUse	ResiComm Bldg

Required Parking (Table 7a)

Building Name	Type	SubUse	Area (Sq.mt.)	Units		Car		Visitors Car		TwoWheeler	
				Reqd.	Prop.	Reqd./Unit	Reqd.	Prop.	Reqd./Unit	Reqd.	Prop.
A1 (RESICOMM BLDG)	Residential	ResiComm Bldg	> 0	1	2.00	1	2	-	-	-	-
			> 0	1	2.00	-	-	-	-	1	2
			> 0	1	2.00	-	-	1	1	-	-
Total :							2	2		1	2

Parking Check (Table 7b)

Vehicle Type	Reqd.		Prop.	
	No.	Area	No.	Area
Car	-	-	2	25.00
Total Car	2	25.00	2	25.00
Visitor's Car Parking	-	-	1	12.50
Total Visitor Parking	1	12.50	1	12.50
TwoWheeler	-	-	2	4.00
Total TwoWheeler	2	4.00	2	4.00
Total		41.50		45.50

AREA STATEMENT SIMDEGA NAGAR PANCHAYAT	VERSION NO. : 1.0.61
PROJECT DETAIL:	VERSION DATE: 16/10/2020
Region: JHARKHAND URBAN LOCAL BODIES	Plot Use: Residential
District: SIMDEGA	Plot SubUse: ResiComm Bldg
Authority: SIMDEGA NAGAR PANCHAYAT	PlotNearbyReligiousStructure: NA
Inward No: SINPC/BP/0250/W05/2021	PlotSubPlot No: 5083
Application Type: General Proposal	North: -
Project Type: Building Permission	South: -
Nature of Development: New	East: -
Location of Development Area: New Area	West: -
AREA DETAILS:	SQ.MT.
AREA OF PLOT (Minimum)	(A) 135.16
Deduction for NetPlot Area	
Surrender Free of Cost	13.10
Total	13.10
NET AREA OF PLOT(Gross Plot Area - Deduction from Gross Plot area)	(A-Deductions) 122.06
Deduction for Balance Plot Area(from Gross Plot Area)	
Surrender Free of Cost	13.10
Common Plot	14.06
Total	27.16
BALANCE AREA OF PLOT(Net Plot Area - Recreational/Amenity space)	(A-Deductions) 108.00
PLOT AREA FOR COVERAGE(Net Plot Area)	(A-Deductions) 122.06
Plot Area for FAR (Net Plot Area + RoadWidening Area)	(A-Deductions) 135.16
COVERAGE CHECK	
Permissible Coverage area (60.00 %)	73.24
Proposed Coverage Area (34.93 %)	42.64
Total Prop. Coverage Area (34.93 %)	42.64
Balance coverage area (25.07 %)	30.60
FAR CHECK	
Perm. FAR Area (2.00)	270.32
Total Perm. FAR area	270.32
Residential FAR	85.29
Commercial FAR	42.64
Proposed FAR Area	127.93
Total Proposed FAR Area	127.93
Consumed FAR (Factor)	0.95
Balance FAR Area	142.39
BUILT UP AREA CHECK	
Total Proposed BuiltUp Area	127.92
ARCHITECT (Regd)	RAM RATAN SINGH
ENGINEER (Regd)	
SUPERVISOR (Regd)	
OWNER (Regd)	AJIT KUMAR
DEVELOPMENT AUTHORITY	LOCAL BODY

COLOR INDEX	
PLOT BOUNDARY	Black
ABUTTING ROAD	Green
PROPOSED CONSTRUCTION	Red
COMMON PLOT	Yellow
ROAD WIDENING AREA	Orange
EXISTING (To be retained)	Blue
EXISTING (To be demolished)	Light Blue

Buildingwise Floor FAR Details

Floor Name	Building Name A1 (RESICOMM BLDG)		Total	
	Proposed Built Up Area (Sq.mt.)	Proposed FAR Area (Sq.mt.)	Total Proposed Built Up Area (Sq.mt.)	Total FAR Area (Sq.mt.)
Ground Floor	42.64	42.64	42.64	42.64
First Floor	42.64	42.64	42.64	42.64
Second Floor	42.64	42.64	42.64	42.64
Terrace Floor	0.00	0.00	0.00	0.00
Total :	127.92	127.92	127.92	127.92

Building USE/SUBUSE Details

Building Name	Building Use	Building SubUse	Building Structure
A1 (RESICOMM BLDG)	Residential	ResiComm Bldg	Non-Highrise

LTP NAME AND SIGNATURE	STRUCTURAL ENG'S NAME AND SIGNATURE	BUILDER NAME AND SIGNATURE	DIGITAL SIGNATURE
RAM RATAN SINGH SINPC/DFTMN/0003/2020			

Proposal Basic Information	
Proposal File No.	SINPC/BP/0250/W05/2021
Owner Name	AJIT KUMAR
Khata No	12
Plot No	5083
Village Name	Goira
Use	Residential
SubUse	ResiComm Bldg

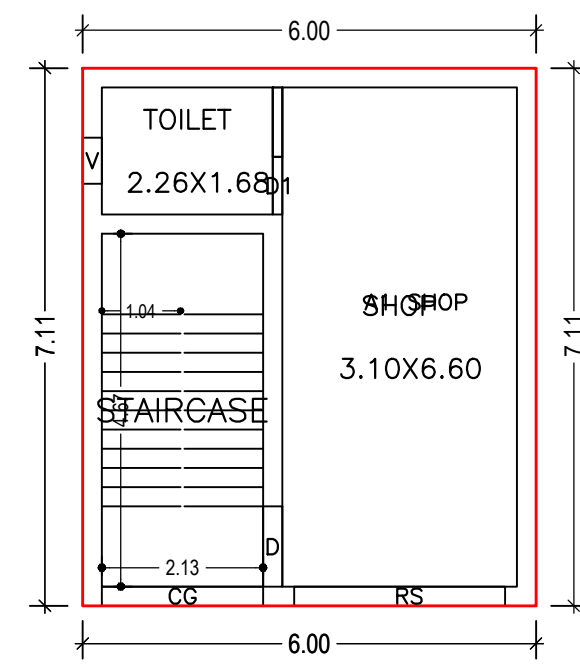

GROUND FLOOR PLAN (Proposed) (SCALE 1:100)

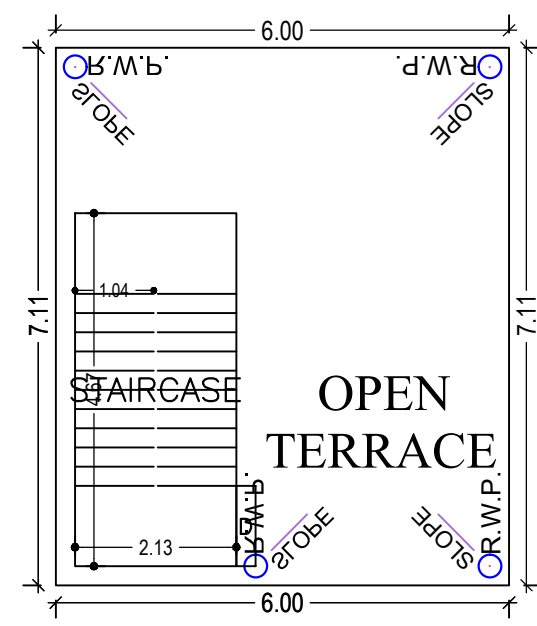

TERRACE FLOOR PLAN (SCALE 1:100)

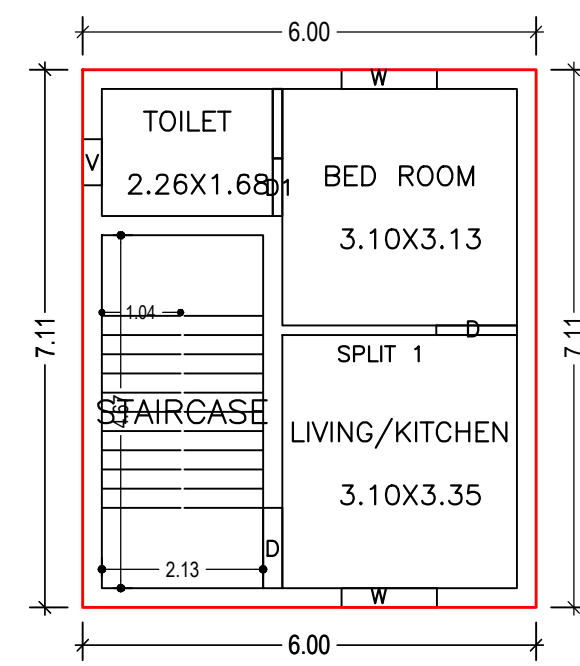

FIRST FLOOR PLAN (Proposed) (SCALE 1:100)

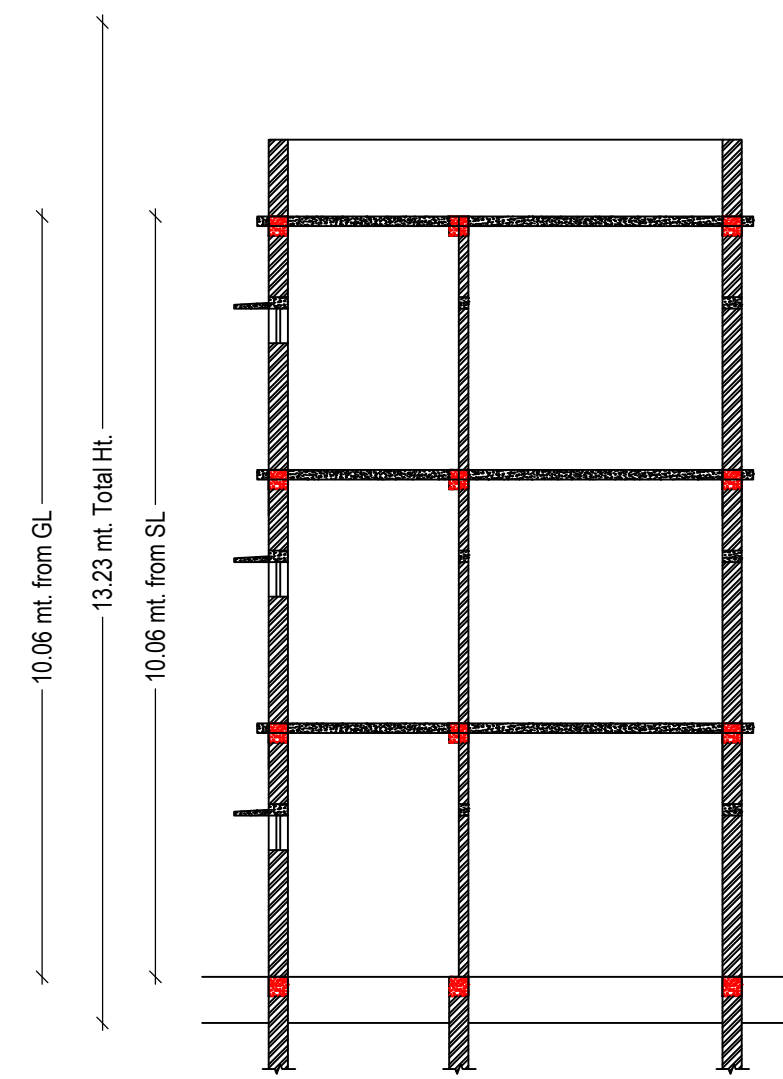

SECTION AT-X-X SCALE 1:100

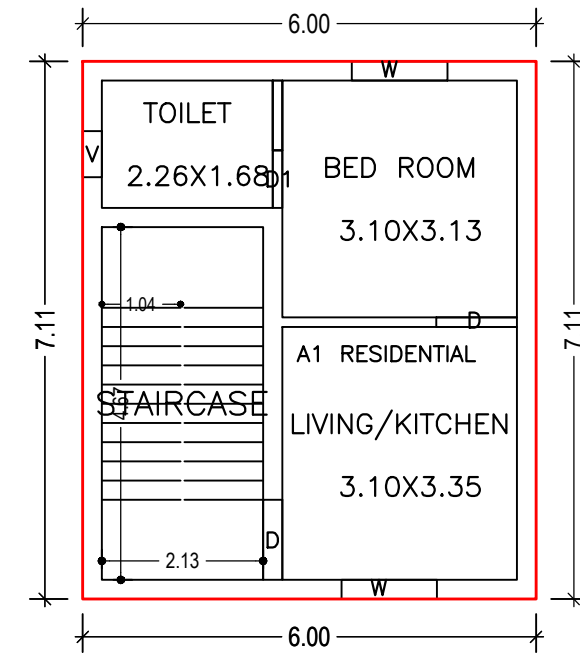

SECOND FLOOR PLAN (Proposed) (SCALE 1:100)

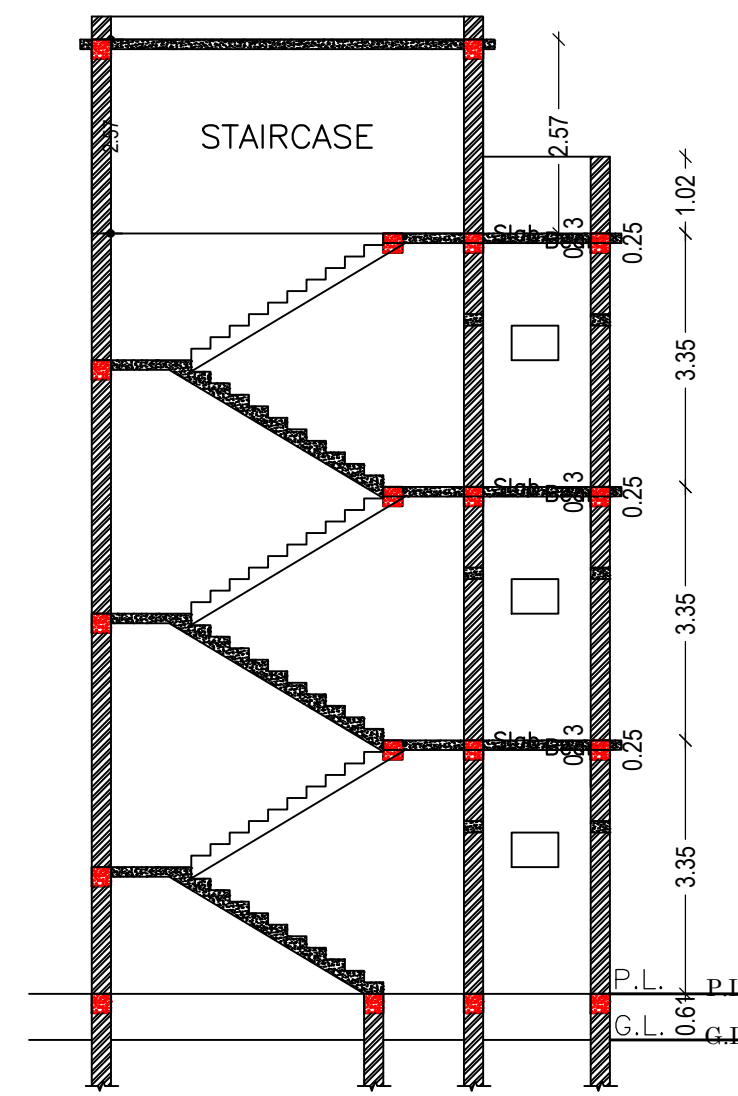

SECTION AT-Y-Y SCALE 1:100

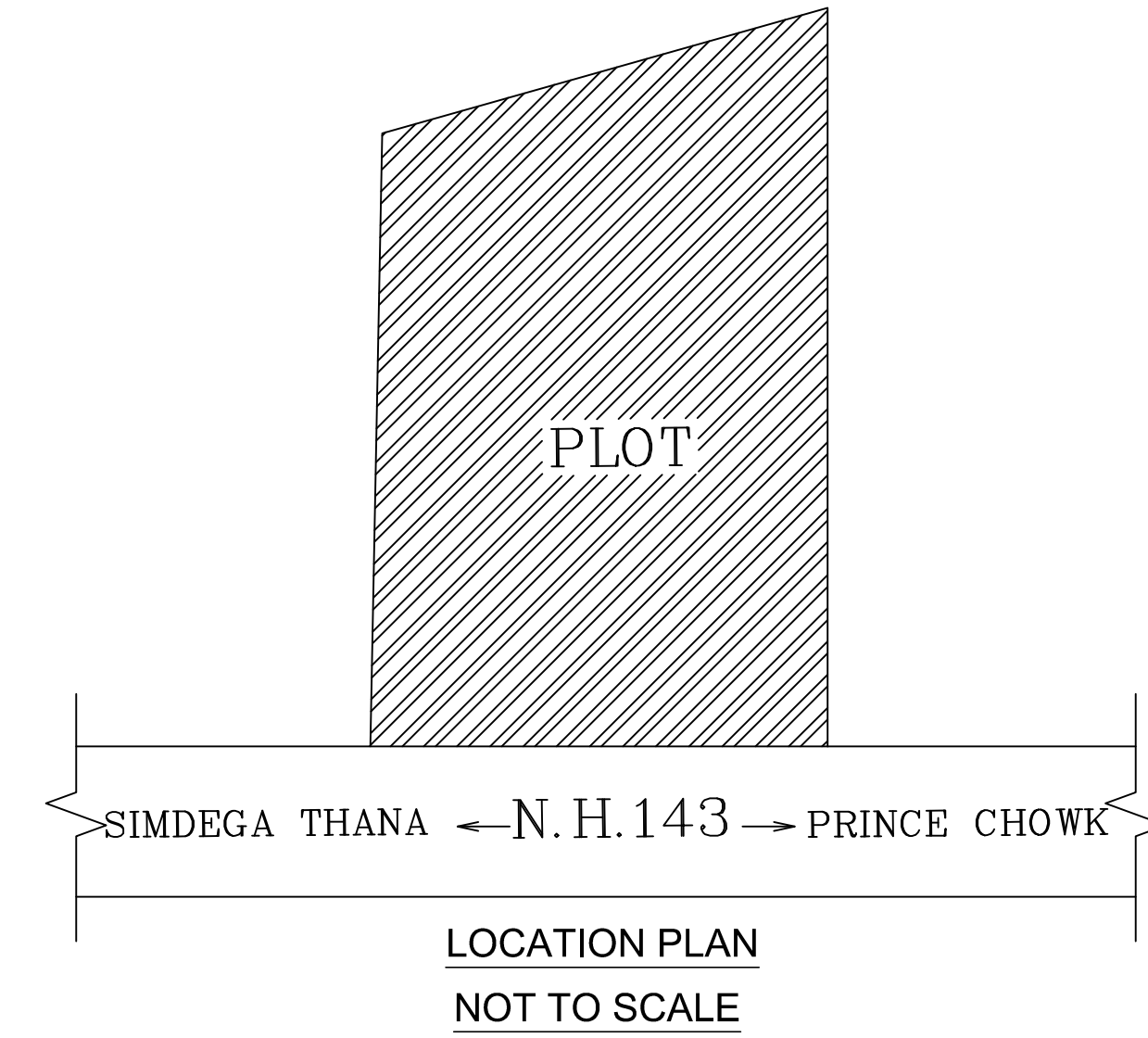

LOCATION PLAN NOT TO SCALE

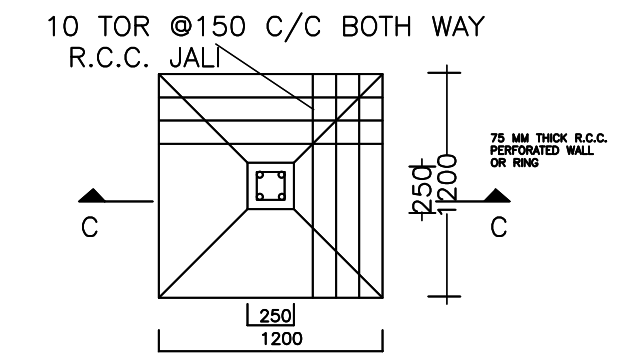

DETAIL OF FOUNDATION

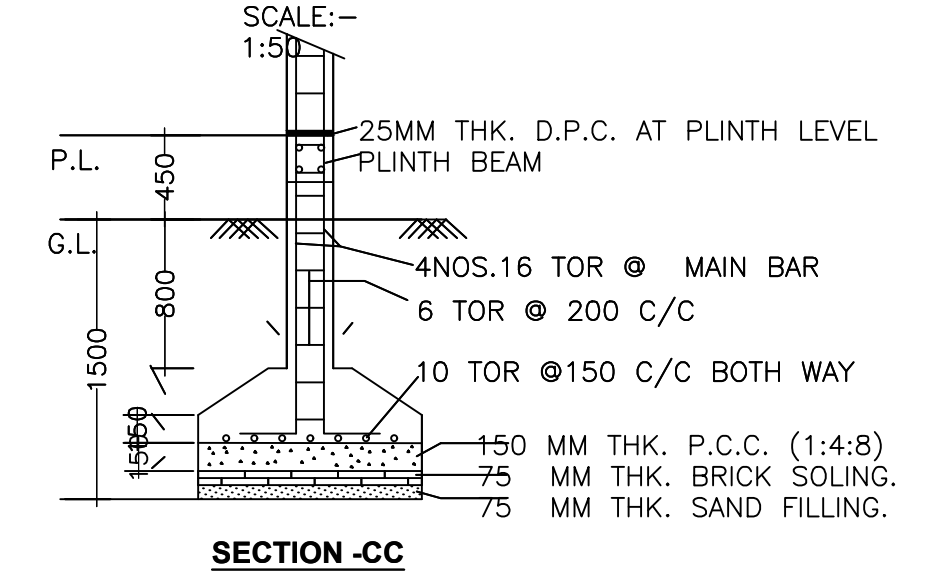

SECTION -CC

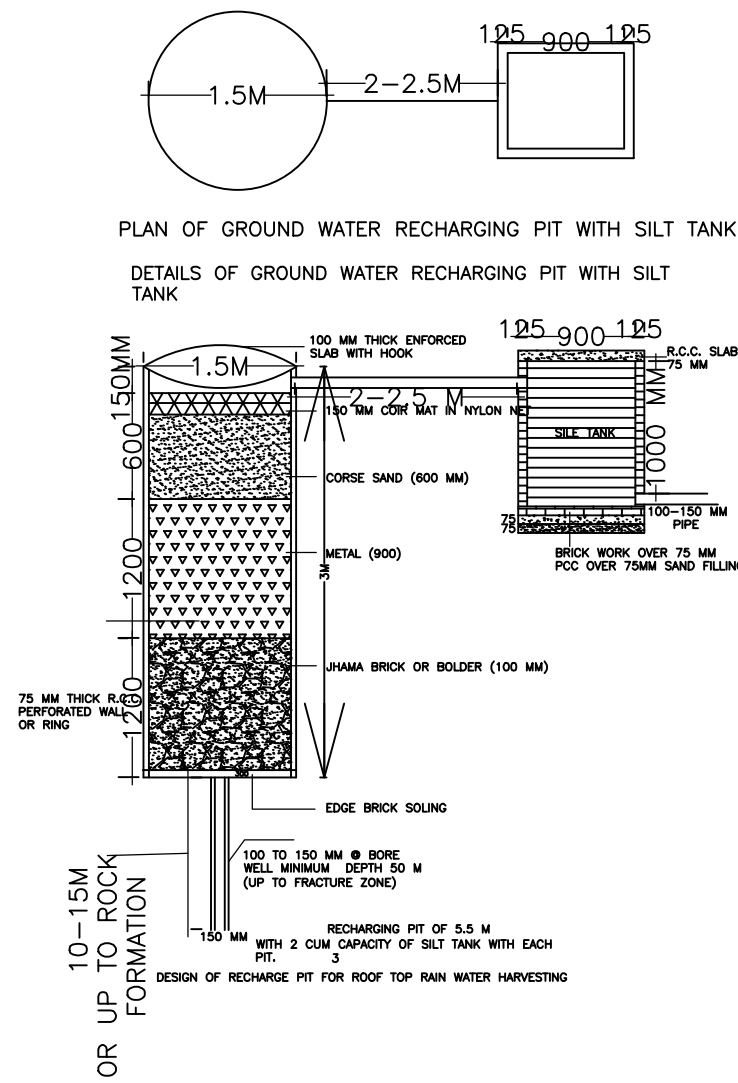

OR UP TO ROCK FORMATION

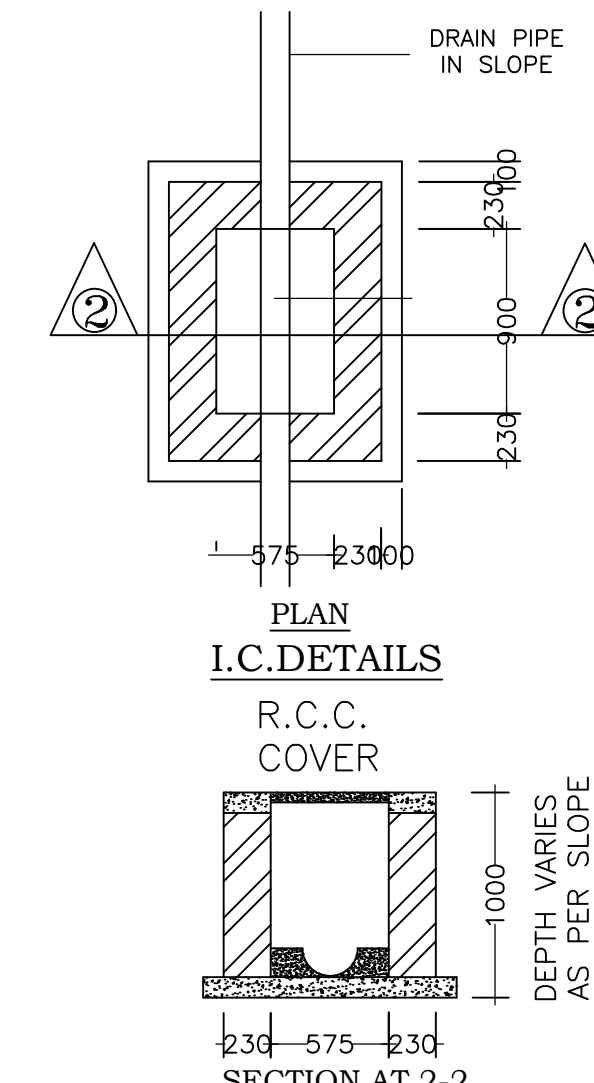

SECTION AT 2-2

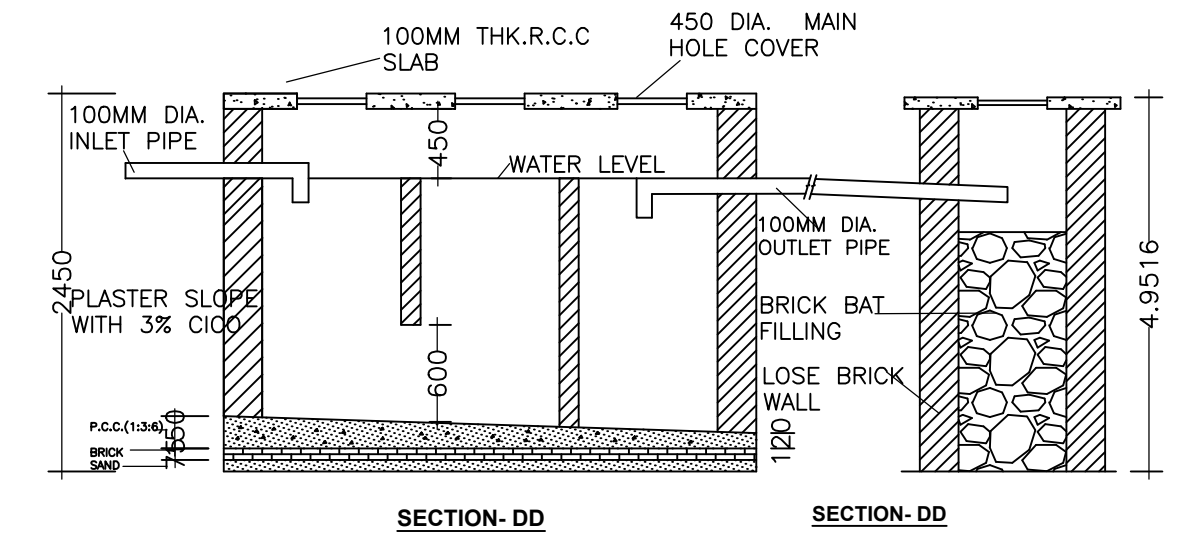

SECTION-DD

SECTION-DD

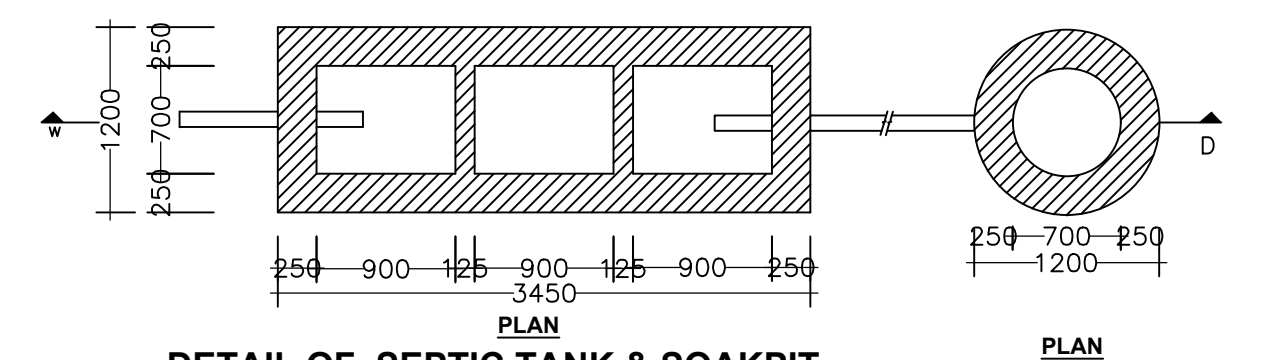

DETAIL OF SEPTIC TANK & SOAKPIT.

SCALE - 1:50

SCHEDULE OF DOOR:

BUILDING NAME	NAME	LENGTH	HEIGHT	NOS
A1 (RESICOMM BLDG)	D1	0.76	2.10	03
A1 (RESICOMM BLDG)	D	1.06	2.10	03
A1 (RESICOMM BLDG)	D	1.07	2.10	02
A1 (RESICOMM BLDG)	RS	2.79	2.10	01

SCHEDULE OF WINDOW/VENTILATION:

BUILDING NAME	NAME	LENGTH	HEIGHT	NOS
A1 (RESICOMM BLDG)	V	0.61	1.20	03
A1 (RESICOMM BLDG)	W	1.26	1.20	04

UnitBUA Table for Building :A1 (RESICOMM BLDG)

FLOOR	Name	UnitBUA Type	UnitBUA Area	Carpet Area	No. of Rooms	No. of Tenement
GROUND FLOOR PLAN	A1 SHOP	SHOP	24.49	24.37	2	1
FIRST FLOOR PLAN	SPLIT 1	FLAT	24.49	24.37	3	1
SECOND FLOOR PLAN	A1 RESIDENTIAL	FLAT	24.49	24.37	3	1
Total:	-	-	73.47	73.11	8	3

Building :A1 (RESICOMM BLDG)

Floor Name	Total Built Up Area (Sq.mt.)	Proposed FAR Area (Sq.mt.) Resi.	Total FAR Area (Sq.mt.)	Total Consumed Additional FAR Area (Sq.mt.)	Tnmt (No.)
Ground Floor	42.64	0.00	42.64	42.64	01
First Floor	42.64	42.64	42.64	42.64	01
Second Floor	42.64	42.64	42.64	42.64	01
Terrace Floor	0.00	0.00	0.00	0.00	00
Total :	127.92	85.28	127.92	127.92	03
Total Number of Same Buildings	1				
Total :	127.92	85.28	127.92	127.92	03

LTP NAME AND SIGNATURE	STRUCTURAL ENG'S NAME AND SIGNATURE	BUILDER NAME AND SIGNATURE	DIGITAL SIGNATURE
RAM RATAN SINGH SINPC/DFTMN/0003/2020			

Proposal Basic Information	
Proposal File No.	SINPC/BP/0250/W05/2021
Owner Name	AJIT KUMAR
Khata No	12
Plot No	5083
Village Name	Gotra
Use	Residential
SubUse	ResiComm Bldg

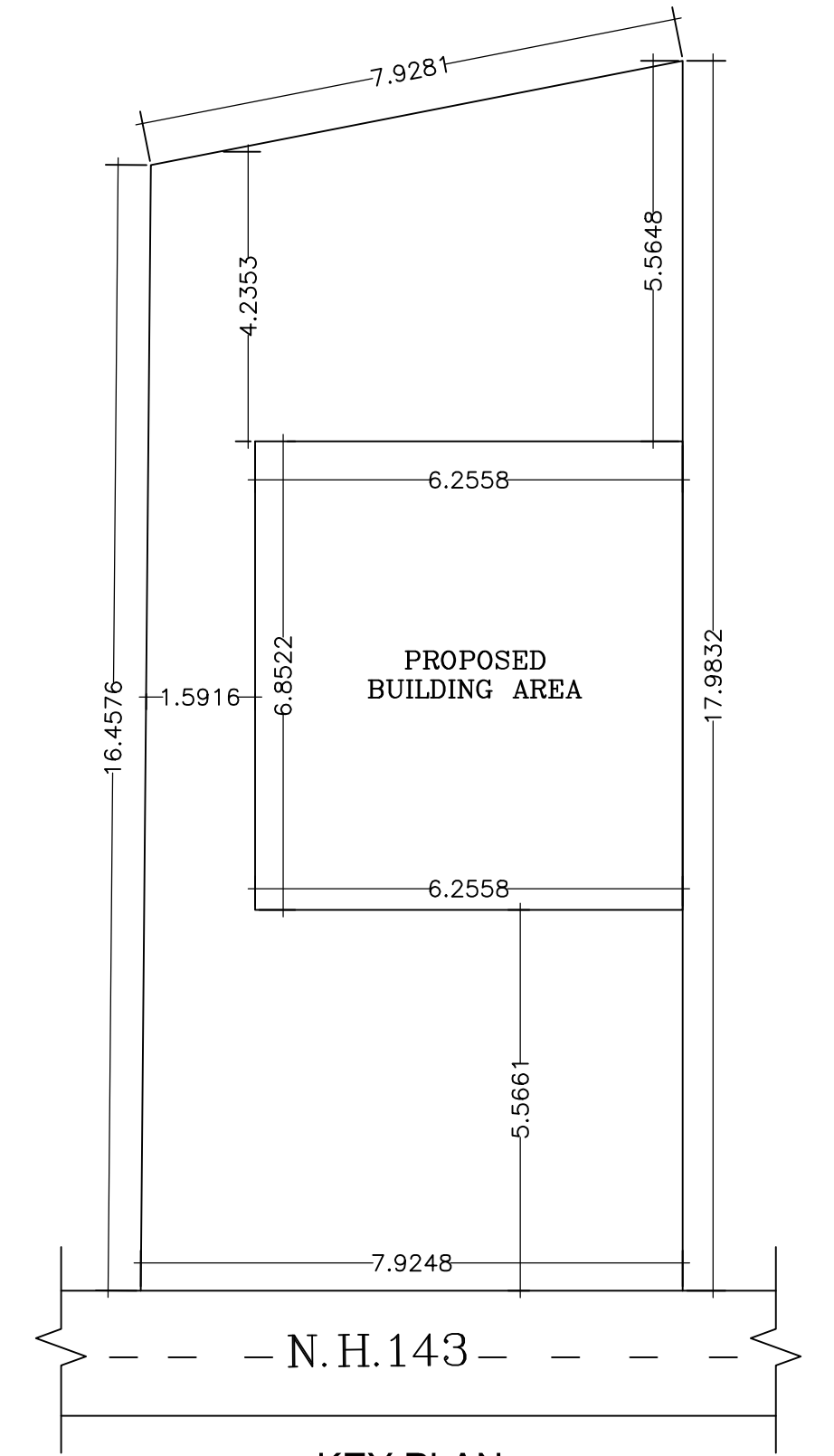

KEY PLAN
SCALE 1:100

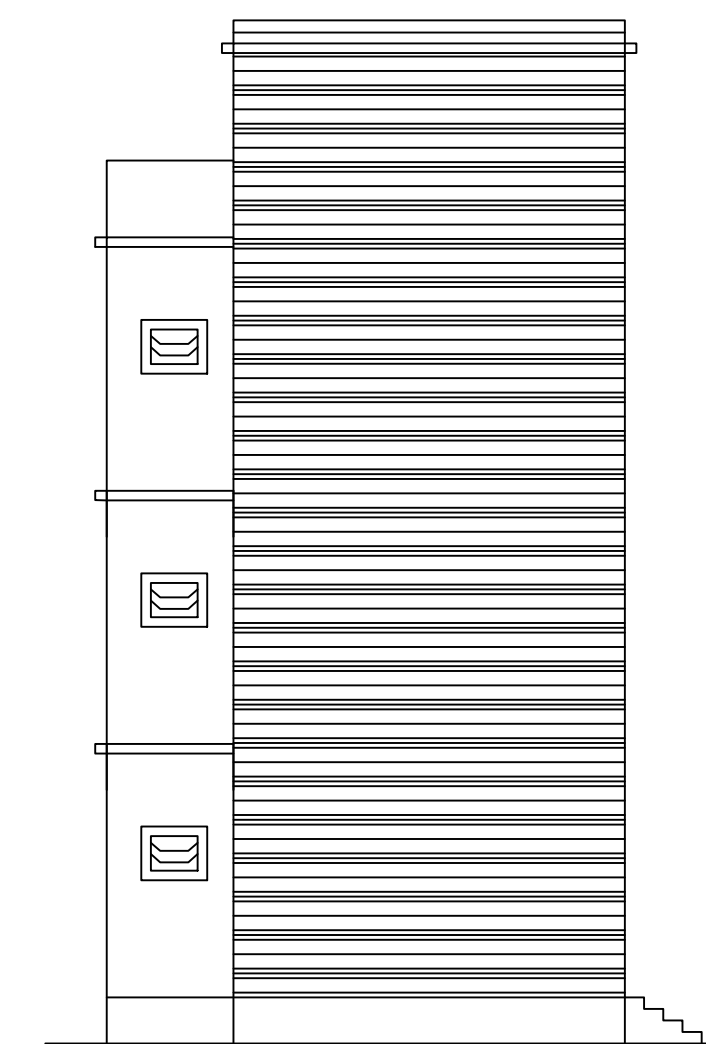

LEFT SIDE ELEVATION
SCALE 1:100

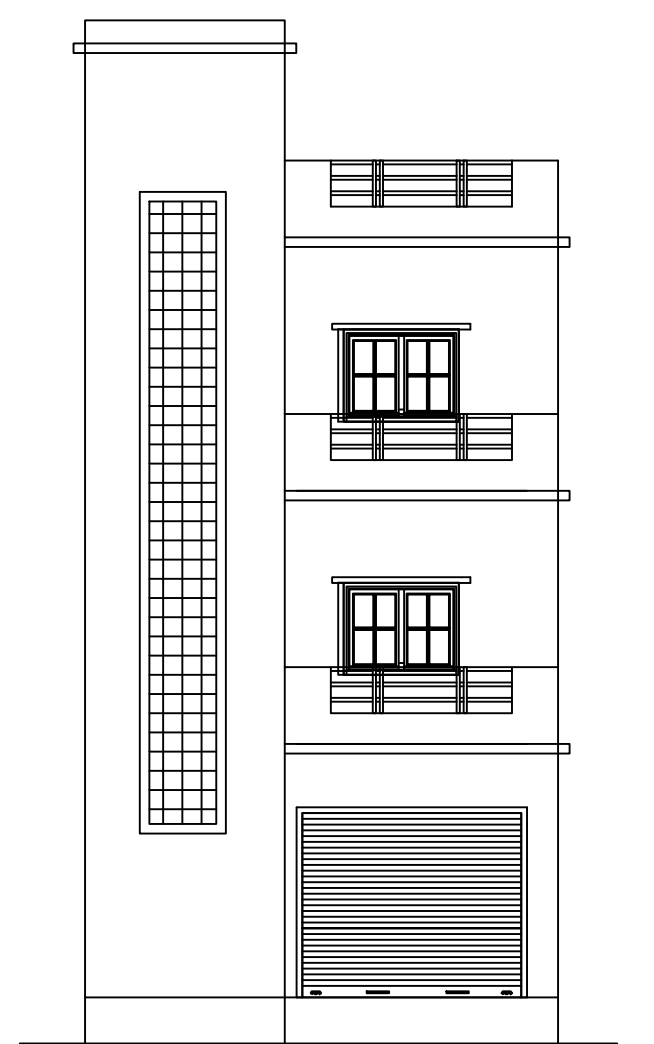

FRONT ELEVATION
SCALE 1:100

LTP NAME AND SIGNATURE	STRUCTURAL ENG'S NAME AND SIGNATURE	BUILDER NAME AND SIGNATURE	DIGITAL SIGNATURE
RAM RATAN SINGH SINPC/DFTMN/0003/2020			