

SITE PLAN

FAR & Tenement Details (Table 4c-1)

Building	No. of Same Bldg	Total Built Up Area (Sq.mt.)	Proposed FAR Area (Sq.mt.) Resi.	Total FAR Area (Sq.mt.)	Total Consumed Additional FAR Area (Sq.mt.)	Tnmt (No.)
A1 (RESIDENSE)	1	195.33	195.33	195.33	195.33	02
Grand Total	1	195.33	195.33	195.33	195.33	02

Proposal Basic Information

Proposal File No.	SINPC/BP/0253/W15/2021
Owner Name	SMT. SUNITI KUJUR
Khata No	135
Plot No	2117
Village Name	Simdega
Use	Residential
SubUse	Bungalow/ Dwelling / Non Apartment

Required Parking (Table 7a)

Building Name	Type	SubUse	Area (Sq.mt.)	Units		Car		Visitors Car		TwoWheeler	
				Reqd.	Prop.	Reqd./Unit	Reqd.	Prop.	Reqd./Unit	Reqd.	Prop.
A1 (RESIDENSE)	Residential	Bungalow/ Dwelling / Non Apartment	> 0	1	2.00	1	2	-	-	-	-
		> 0	1	2.00	-	-	1	1	-	-	
Total			-	-	-	2	2	-	1	2	0

Parking Check (Table 7b)

Vehicle Type	Reqd.		Prop.	
	No.	Area	No.	Area
Car	-	-	2	25.00
Total Car	2	25.00	2	25.00
Visitor's Car Parking	-	-	2	25.09
Total Visitor Parking	1	12.50	2	25.09
TwoWheeler	-	-	4	10.12
Total TwoWheeler	-	-	4	10.12
Total		37.50		70.33

AREA STATEMENT SIMDEGA NAGAR PANCHAYAT	VERSION NO: 1.0.61	VERSION DATE: 16/10/2020
PROJECT DETAIL	Plot Use: Residential	
Region: JHARKHAND URBAN LOCAL BODIES	Plot SubUse: Bungalow/ Dwelling / Non Apartment	
District: SIMDEGA	PlotNearby/ReligiousStructure: NA	
Authority: SIMDEGA NAGAR PANCHAYAT	PlotSubPlotNo: 2117	
Inward No: SINPC/BP/0253/W15/2021	North: -	
Application Type: General Proposal	South: -	
Project Type: Building Permission	East: -	
Nature of Development: New	West: -	
Location of Development Area: Old Area		
AREA DETAILS:		SQ.MT.
AREA OF PLOT (Minimum)	(A)	575.31
NET AREA OF PLOT (Gross Plot Area - Deduction from Gross Plot area)	(A-Deductions)	575.31
Deduction for Balance Plot Area (from Gross Plot Area)		
Common Plot		39.11
Total		39.11
BALANCE AREA OF PLOT (Net Plot Area - Recreational/Amenity space)	(A-Deductions)	536.20
PLOT AREA FOR COVERAGE (Net Plot Area)	(A-Deductions)	575.31
Plot Area for FAR (Net Plot Area + Road Widening Area)	(A-Deductions)	575.31
COVERAGE CHECK		
Permissible Coverage area (60.00 %)		345.19
Proposed Coverage Area (20.52 %)		118.03
Total Prop. Coverage Area (20.52 %)		118.03
Balance coverage area (39.48 %)		227.16
FAR CHECK		
Perm. FAR Area (1.50)		862.96
Total Perm. FAR area		862.96
Residential FAR		195.32
Proposed FAR Area		195.32
Total Proposed FAR Area		195.32
Consumed FAR (Factor)		0.34
Balance FAR Area		667.64
BUILT UP AREA CHECK		
Total Proposed BuiltUp Area		195.33
ARCHITECT (Regd)	RAM RATAN SINGH	
ENGINEER (Regd)		
SUPERVISOR (Regd)		
OWNER (Regd)	SMT. SUNITI KUJUR	
DEVELOPMENT AUTHORITY		LOCAL BODY

COLOR INDEX

PLOT BOUNDARY	
ABUTTING ROAD	
PROPOSED CONSTRUCTION	
COMMON PLOT	
ROAD WIDENING AREA	
EXISTING (To be retained)	
EXISTING (To be demolished)	

Buildingwise Floor FAR Details

Floor Name	Building Name A1 (RESIDENSE)		Total	
	Proposed Built Up Area (Sq.mt.)	Proposed FAR Area (Sq.mt.)	Total Proposed Built Up Area (Sq.mt.)	Total FAR Area (Sq.mt.)
Ground Floor	118.03	118.03	118.03	118.03
First Floor	77.30	77.30	77.30	77.30
Terrace Floor	0.00	0.00	0.00	0.00
Total	195.33	195.33	195.33	195.33

Building USE/SUBUSE Details

Building Name	Building Use	Building SubUse	Building Structure
A1 (RESIDENSE)	Residential	Bungalow/ Dwelling / Non Apartment	Non-Highrise

LTP NAME AND SIGNATURE	STRUCTURAL ENG'S NAME AND SIGNATURE	BUILDER NAME AND SIGNATURE	DIGITAL SIGNATURE
RAM RATAN SINGH SINPC/DFTMN/0003/2020			

Proposal Basic Information

Proposal File No.	SINPC/BP/0253/W15/2021
Owner Name	SMT. SUNITI KUJUR
Khata No	135
Plot No	2117
Village Name	Simdega
Use	Residential
SubUse	Bungalow/ Dwelling / Non Apartment

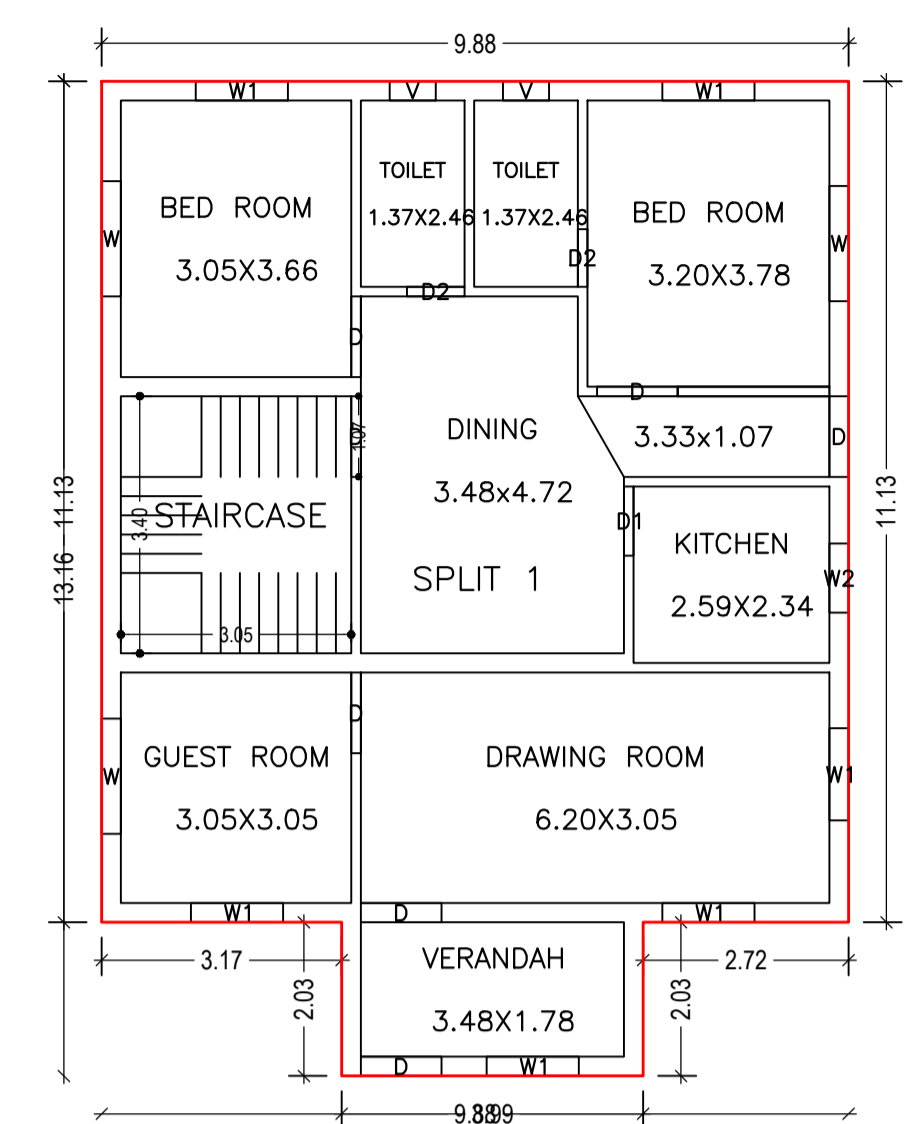

GROUND FLOOR PLAN (Proposed) (SCALE 1:100)

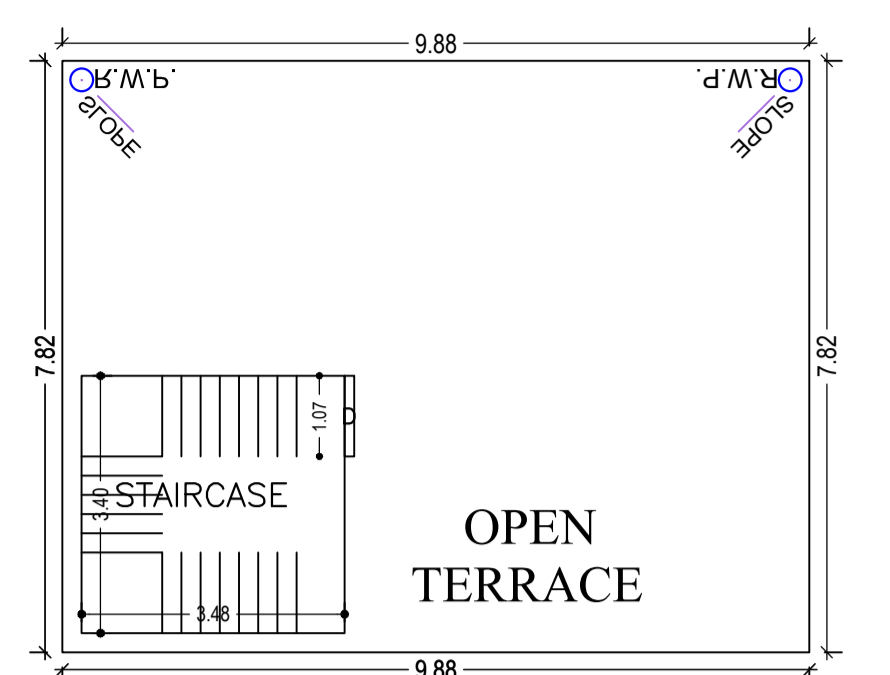

TERRACE FLOOR PLAN (SCALE 1:100)

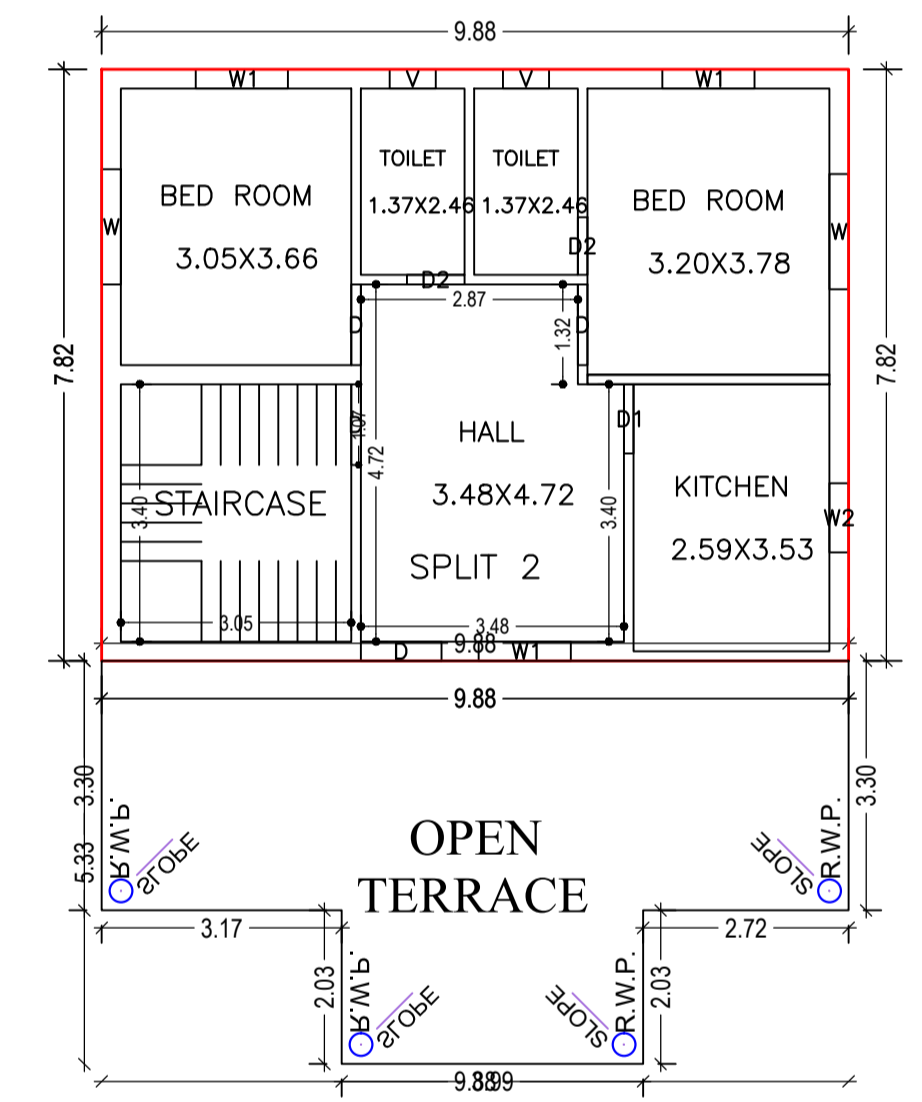

FIRST FLOOR PLAN (Proposed) (SCALE 1:100)

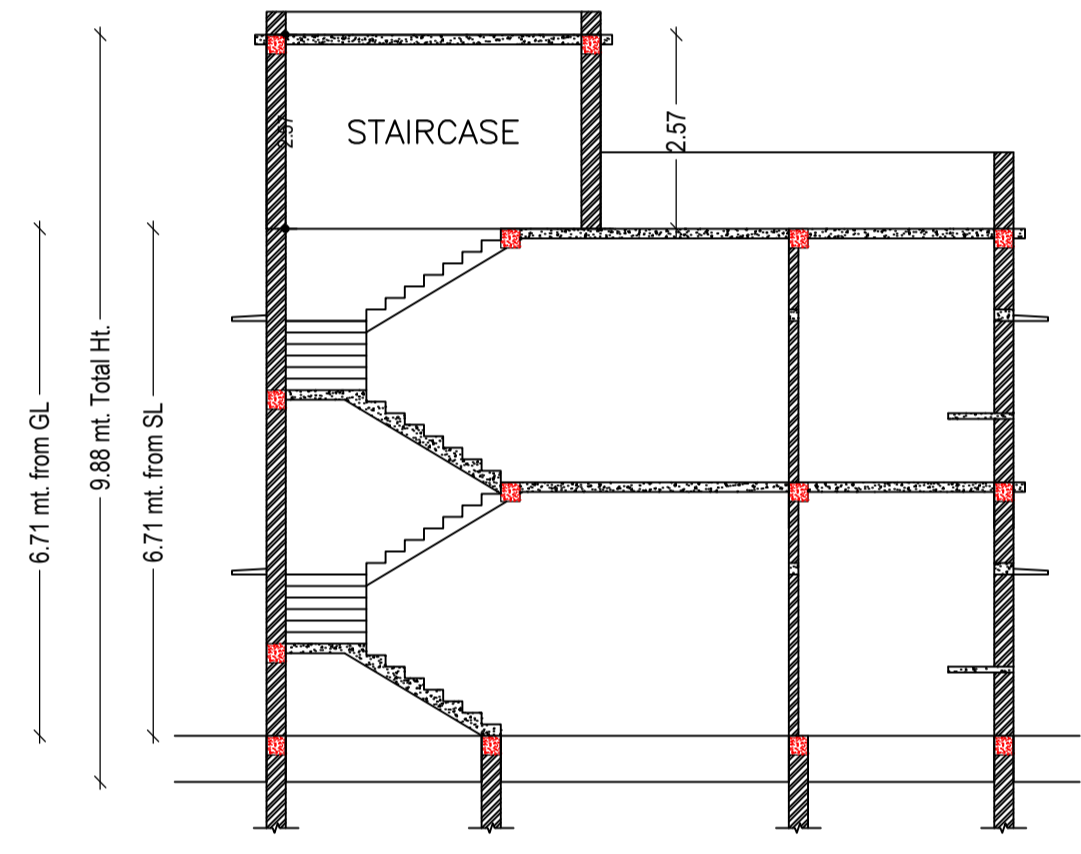

SECTION AT-X-X (SCALE 1:100)

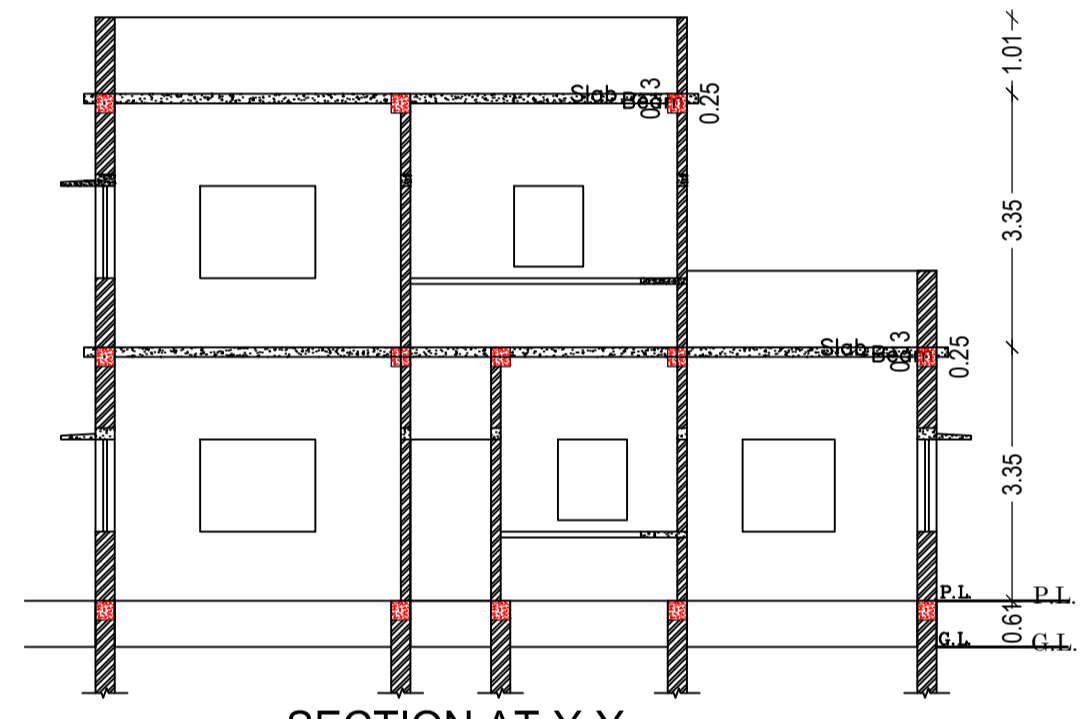

SECTION AT-Y-Y (SCALE 1:100)



FRONT ELEVATION (SCALE 1:100)

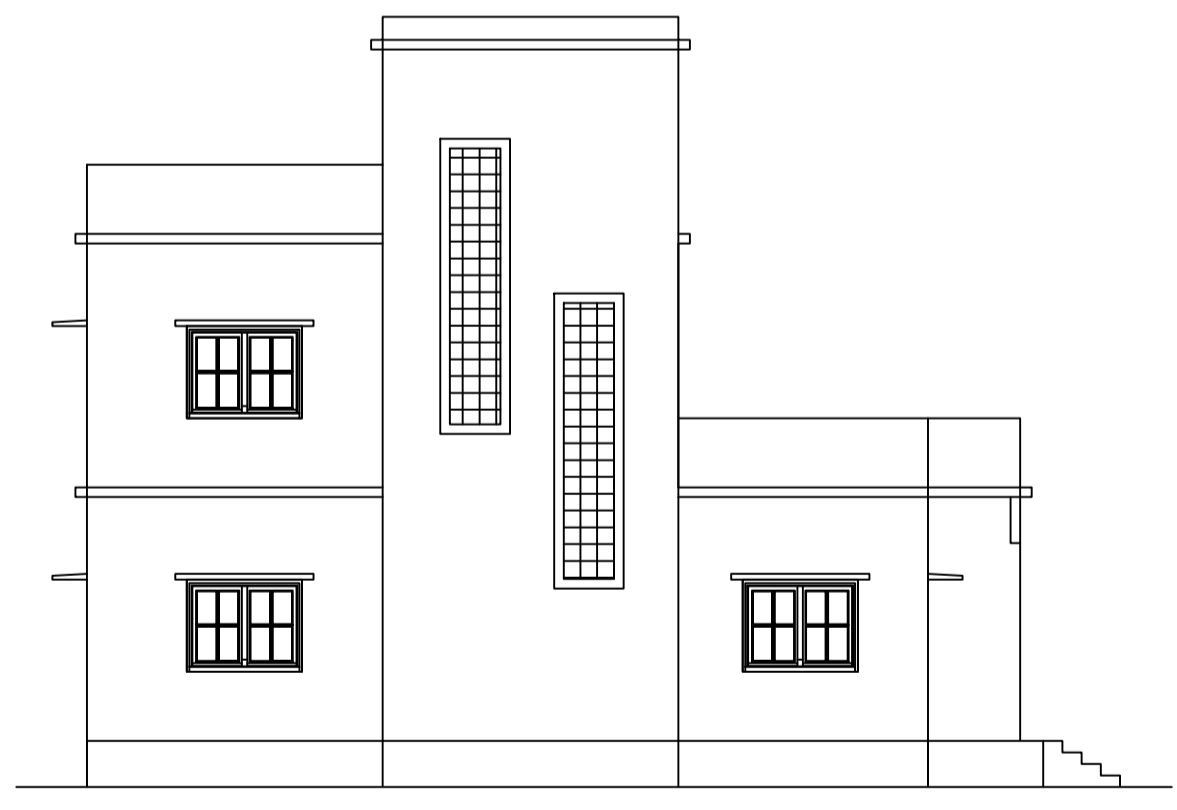

RIGHT SIDE ELEVATION (SCALE 1:100)

Building :A1 (RESIDENSE)

Floor Name	Total Built Up Area (Sq.mt.)	Proposed FAR Area (Sq.mt.)	Total FAR Area (Sq.mt.)	Total Consumed Additional FAR Area (Sq.mt.)	Tnmt (No.)
Ground Floor	118.03	118.03	118.03	118.03	01
First Floor	77.30	77.30	77.30	77.30	01
Terrace Floor	0.00	0.00	0.00	0.00	00
Total :	195.33	195.33	195.33	195.33	02
Total Number of Same Buildings	1				
Total :	195.33	195.33	195.33	195.33	02

SCHEDULE OF DOOR:

BUILDING NAME	NAME	LENGTH	HEIGHT	NOS
A1 (RESIDENSE)	D2	0.76	2.10	04
A1 (RESIDENSE)	D1	0.91	2.10	02
A1 (RESIDENSE)	D	1.07	2.10	11

SCHEDULE OF WINDOW/VENTILATION:

BUILDING NAME	NAME	LENGTH	HEIGHT	NOS
A1 (RESIDENSE)	V	0.61	1.20	04
A1 (RESIDENSE)	W2	0.91	1.20	02
A1 (RESIDENSE)	W1	1.22	1.20	09
A1 (RESIDENSE)	W	1.52	1.20	05

UnitBUA Table for Building :A1 (RESIDENSE)

FLOOR	Name	UnitBUA Type	UnitBUA Area	Carpet Area	No. of Rooms	No. of Tenement
GROUND FLOOR PLAN	SPLIT 1	FLAT	94.16	93.91	9	1
FIRST FLOOR PLAN	SPLIT 2	FLAT	57.74	57.33	6	1
Total:	-	-	151.90	151.24	15	2

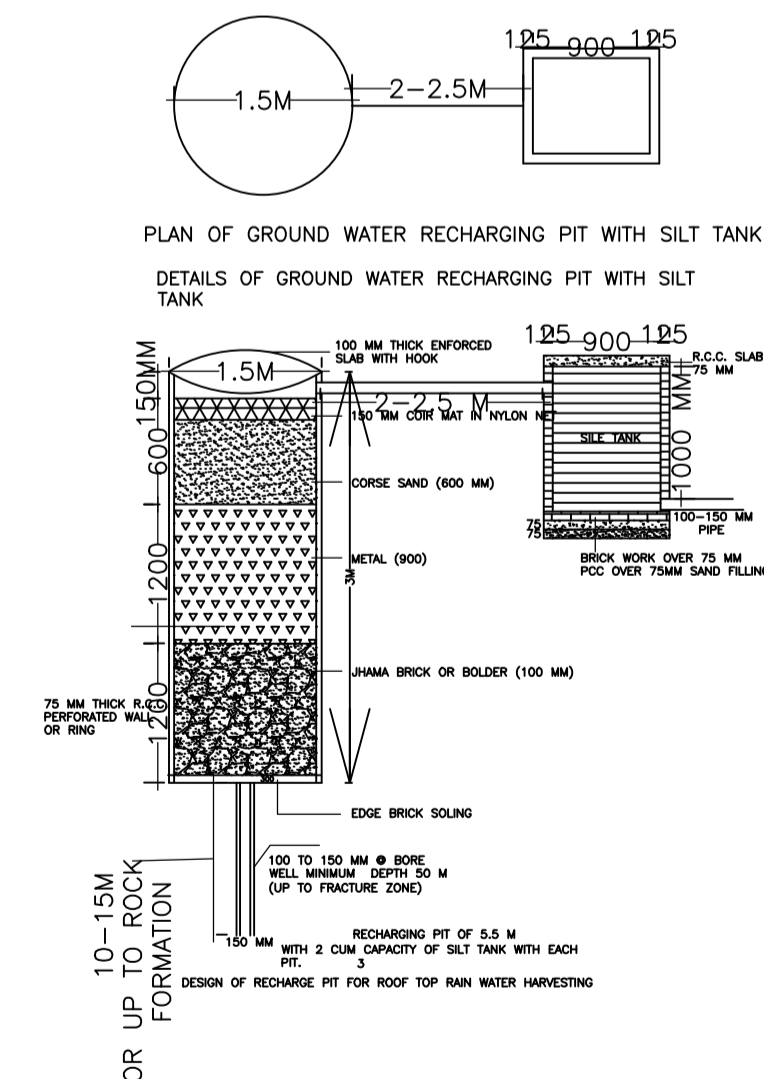

PLAN OF GROUND WATER RECHARGING PIT WITH SILT TANK

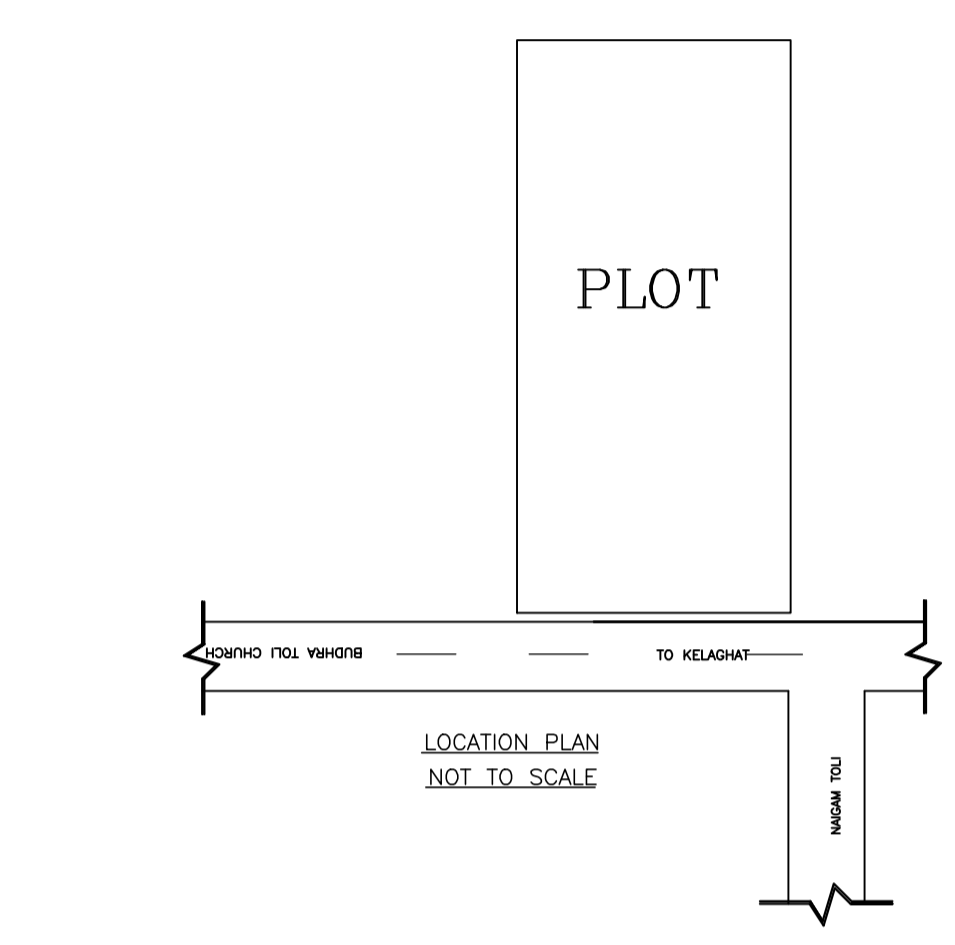

LOCATION PLAN (NOT TO SCALE)

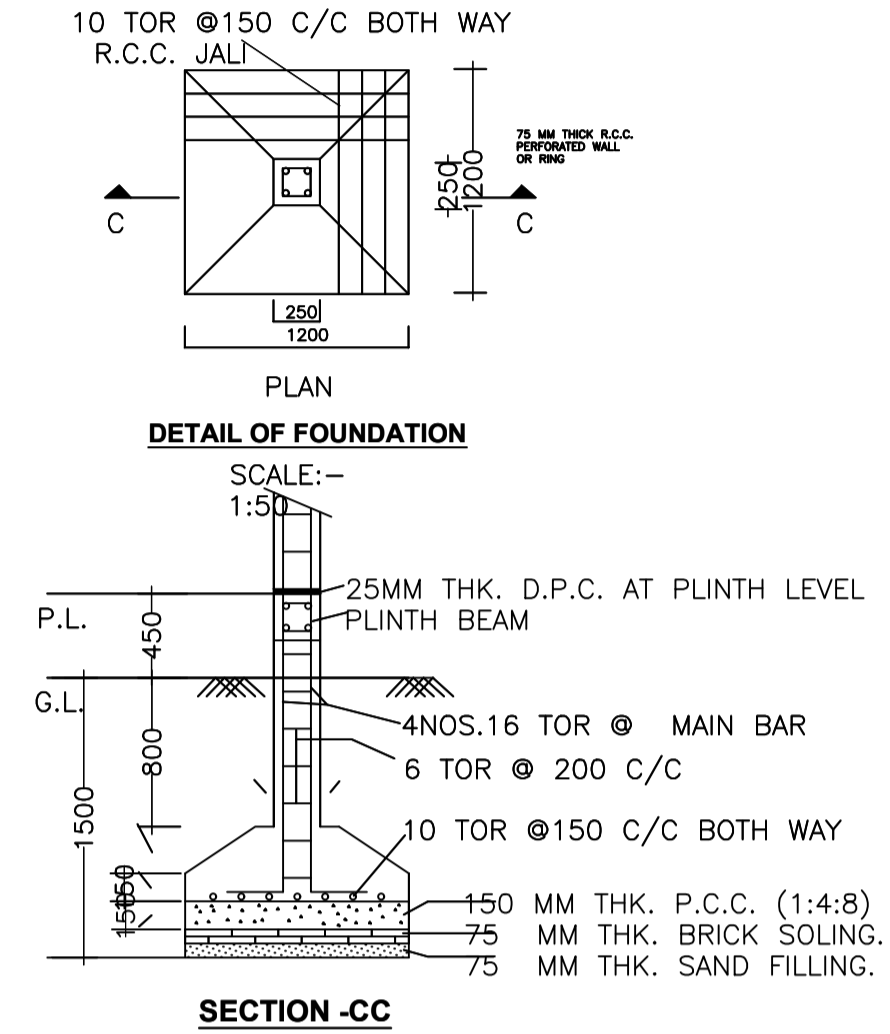

DETAIL OF FOUNDATION (SCALE: 1:50)

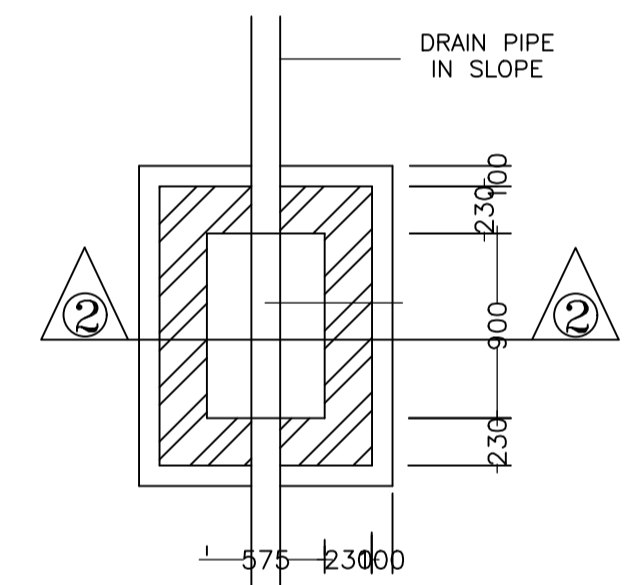

I.C. DETAILS (SCALE 1:50)

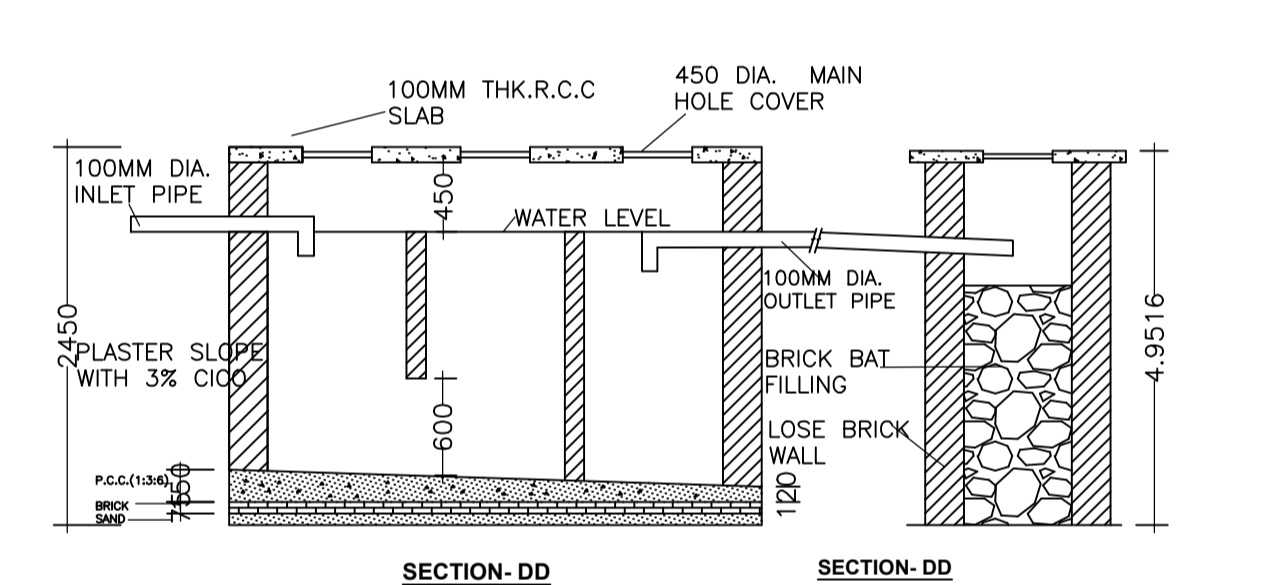

SECTION-DD

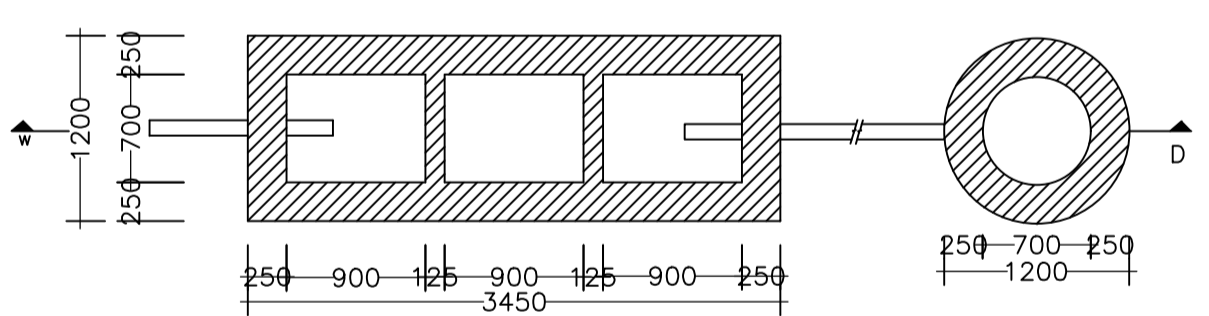

DETAIL OF SEPTIC TANK & SOAKPIT. PLAN (SCALE - 1:50)

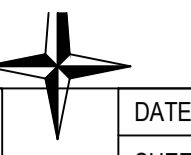

Proposal Basic Information	
Proposal File No.	SINPC/BP/0253/W15/2021
Owner Name	SMT. SUNITI KUJUR
Khata No	135
Plot No	2117
Village Name	Simdega
Use	Residential
SubUse	Bungalow/ Dwelling / Non Apartment

KEY PLAN
SCALE 1:200

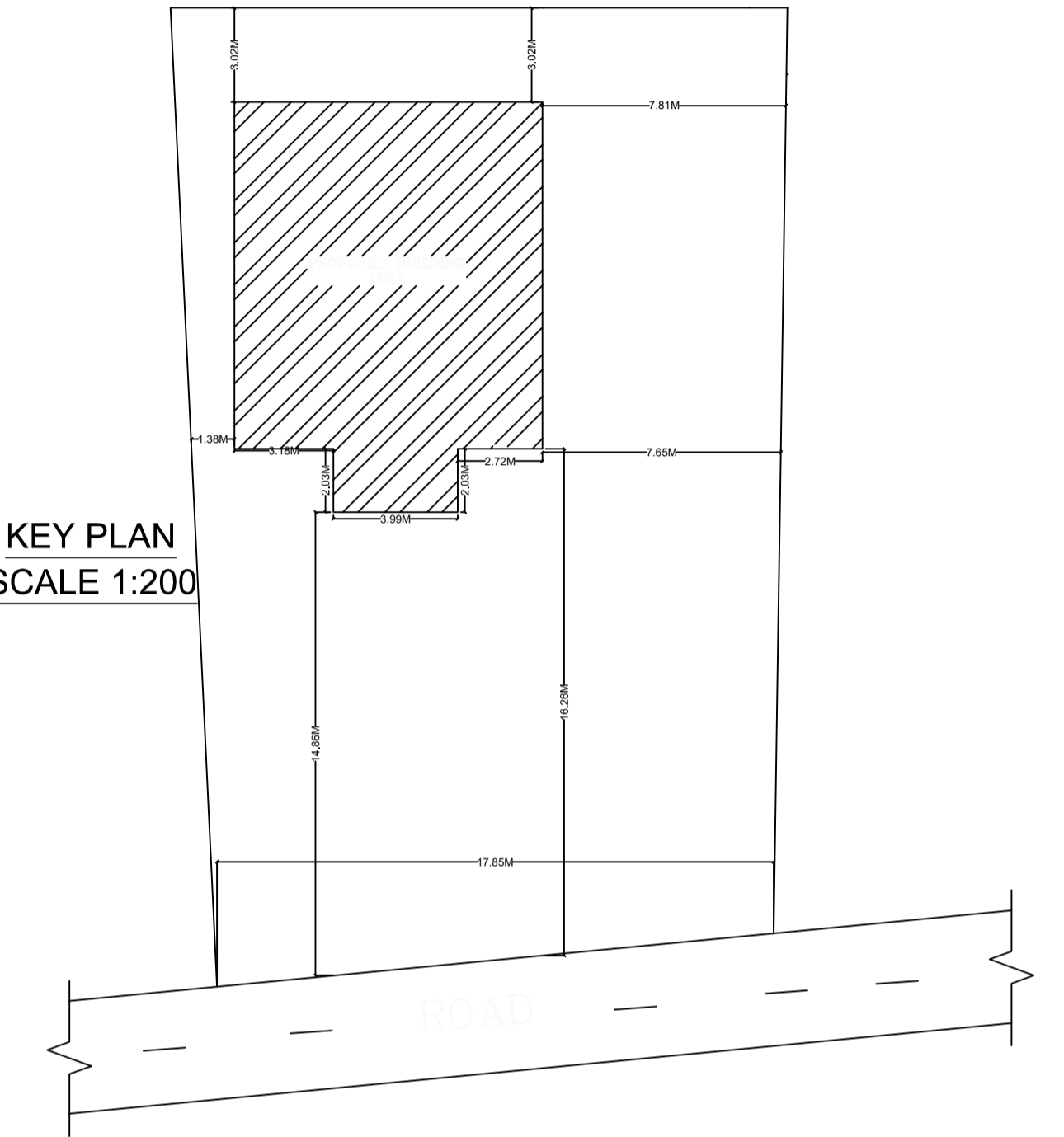

LTP NAME AND SIGNATURE	STRUCTURAL ENG'S NAME AND SIGNATURE	BUILDER NAME AND SIGNATURE	DIGITAL SIGNATURE
RAM RATAN SINGH SINPC/DFTMN/0003/2020			