

SITE PLAN

FAR & Tenement Details (Table 4c-1)

Building	No. of Same Bldg	Total Built Up Area (Sq.mt.)	Proposed FAR Area (Sq.mt.) Resi.	Total FAR Area (Sq.mt.)	Total Consumed Additional FAR Area (Sq.mt.)	Tnmt (No.)
A1 (RESIDENSE)	1	184.48	184.48	184.48	184.48	02
Grand Total :	1	184.48	184.48	184.48	184.48	02

Proposal Basic Information

Proposal File No.	SINPC/BP/0255/W02/2021
Owner Name	SMITA TIGGA
Khata No	120
Plot No	4992
Village Name	Gotra
Use	Residential
SubUse	Bungalow/ Dwelling / Non Apartment

Required Parking (Table 7a)

Building Name	Type	SubUse	Area (Sq.mt.)	Units		Car		Visitors Car		TwoWheeler		
				Reqd.	Prop.	Reqd./Unit	Prop.	Reqd./Unit	Prop.	Reqd./Unit	Prop.	
A1 (RESIDENSE)	Residential	Bungalow/ Dwelling / Non Apartment	> 0	1	2.00	1	2	-	-	-	-	-
			> 0	1	2.00	-	-	1	1	-	-	-
			Total :	-	-	-	-	2	2	-	1	2

Parking Check (Table 7b)

Vehicle Type	Reqd.		Prop.	
	No.	Area	No.	Area
Car	-	-	2	25.00
Total Car	2	25.00	2	25.00
Visitor's Car Parking	-	-	2	25.09
Total Visitor Parking	1	12.50	2	25.09
TwoWheeler	-	-	4	10.12
Total TwoWheeler	-	-	4	10.12
Total	37.50		70.33	

AREA STATEMENT SIMDEGA NAGAR PANCHAYAT	VERSION NO.: 1.0.61	SQ.MT.
PROJECT DETAIL:	VERSION DATE: 16/10/2020	
Region: JHARKHAND URBAN LOCAL BODIES	Plot Use: Residential	
District: SIMDEGA	Plot SubUse: Bungalow/ Dwelling / Non Apartment	
Authority: SIMDEGA NAGAR PANCHAYAT	PlotNearby/ReligiousStructure: NA	
Inward No: SINPC/BP/0255/W02/2021	Plot/SubPlot No: 4992	
Application Type: General Proposal	North: -	
Project Type: Building Permission	South: -	
Nature of Development: New	East: -	
Location of Development Area: Old Area	West: -	
AREA DETAILS:		
AREA OF PLOT (Minimum)	(A)	391.81
NET AREA OF PLOT(Gross Plot Area - Deduction from Gross Plot area)	(A-Deductions)	391.81
Deduction for Balance Plot Area(from Gross Plot Area)		
Common Plot		33.92
Total		33.92
BALANCE AREA OF PLOT(Net Plot Area - Recreational/Amenity space)	(A-Deductions)	357.90
PLOT AREA FOR COVERAGE(Net Plot Area)	(A-Deductions)	391.81
Plot Area for FAR (Net Plot Area + Road Widening Area)	(A-Deductions)	391.81
COVERAGE CHECK		
Permissible Coverage area ( 60.00 % )		235.09
Proposed Coverage Area ( 23.54 % )		92.24
Total Prop. Coverage Area ( 23.54 % )		92.24
Balance coverage area ( 36.46 % )		142.85
FAR CHECK		
Perm. FAR Area ( 1.50 )		587.71
Total Perm. FAR area		587.71
Residential FAR		184.47
Proposed FAR Area		184.47
Total Proposed FAR Area		184.47
Consumed FAR (Factor)		0.47
Balance FAR Area		403.24
BUILT UP AREA CHECK		
Total Proposed BuiltUp Area		184.48
ARCHITECT (Regd)	RAM RATAN SINGH	
ENGINEER (Regd)		
SUPERVISOR (Regd)		
OWNER (Regd)	SMITA TIGGA	
DEVELOPMENT AUTHORITY	LOCAL BODY	

COLOR INDEX	
PLOT BOUNDARY	Black
ABUTTING ROAD	Green
PROPOSED CONSTRUCTION	Red
COMMON PLOT	Yellow
ROAD WIDENING AREA	Blue
EXISTING (To be retained)	Orange
EXISTING (To be demolished)	Light Blue

Buildingwise Floor FAR Details

Floor Name	Building Name A1 (RESIDENSE)		Total	
	Proposed Built Up Area (Sq.mt.)	Proposed FAR Area (Sq.mt.)	Total Proposed Built Up Area (Sq.mt.)	Total FAR Area (Sq.mt.)
Ground Floor	92.24	92.24	92.24	92.24
First Floor	92.24	92.24	92.24	92.24
Terrace Floor	0.00	0.00	0.00	0.00
Total :	184.48	184.48	184.48	184.48

Building USE/SUBUSE Details

Building Name	Building Use	Building SubUse	Building Structure
A1 (RESIDENSE)	Residential	Bungalow/ Dwelling / Non Apartment	Non-Highrise

LTP NAME AND SIGNATURE	STRUCTURAL ENG'S NAME AND SIGNATURE	BUILDER NAME AND SIGNATURE	DIGITAL SIGNATURE
RAM RATAN SINGH SINPC/DFTMN/0003/2020			

Proposal Basic Information

Proposal File No.	SINPC/BP/0255/W02/2021
Owner Name	SMITA TIGGA
Khata No	120
Plot No	4992
Village Name	Gotra
Use	Residential
SubUse	Bungalow/ Dwelling / Non Apartment

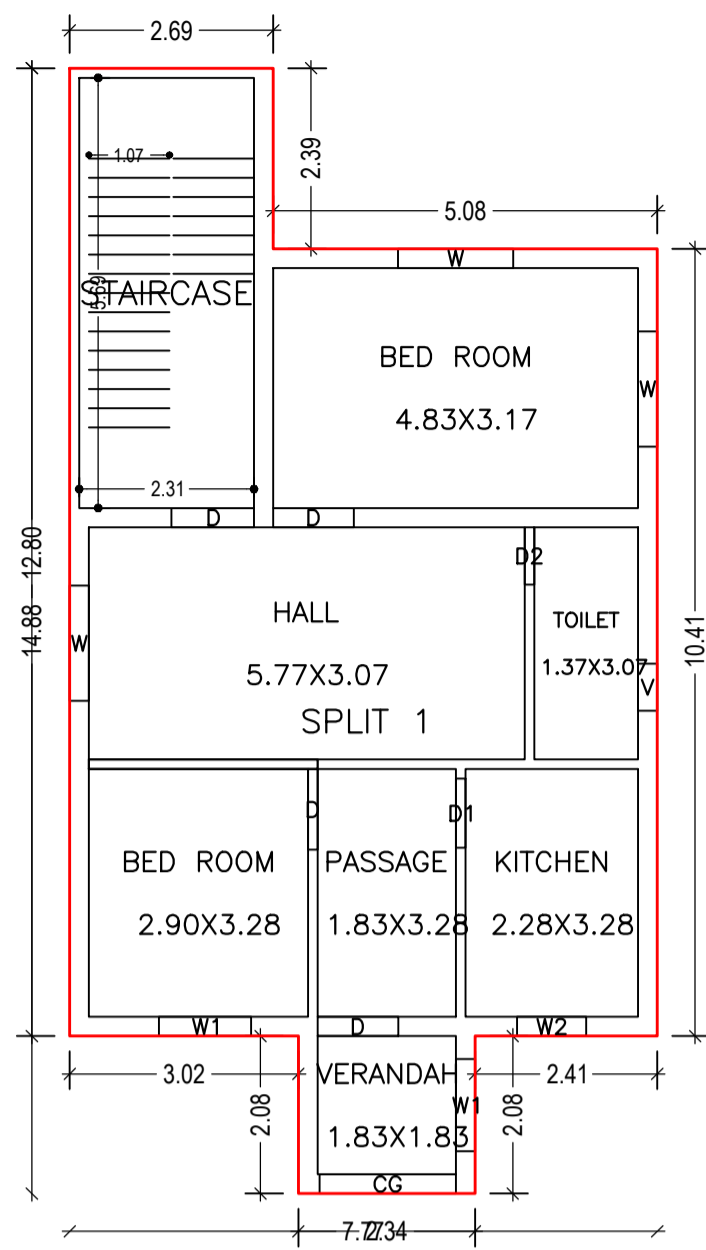

GROUND FLOOR PLAN (Proposed) (SCALE 1:100)

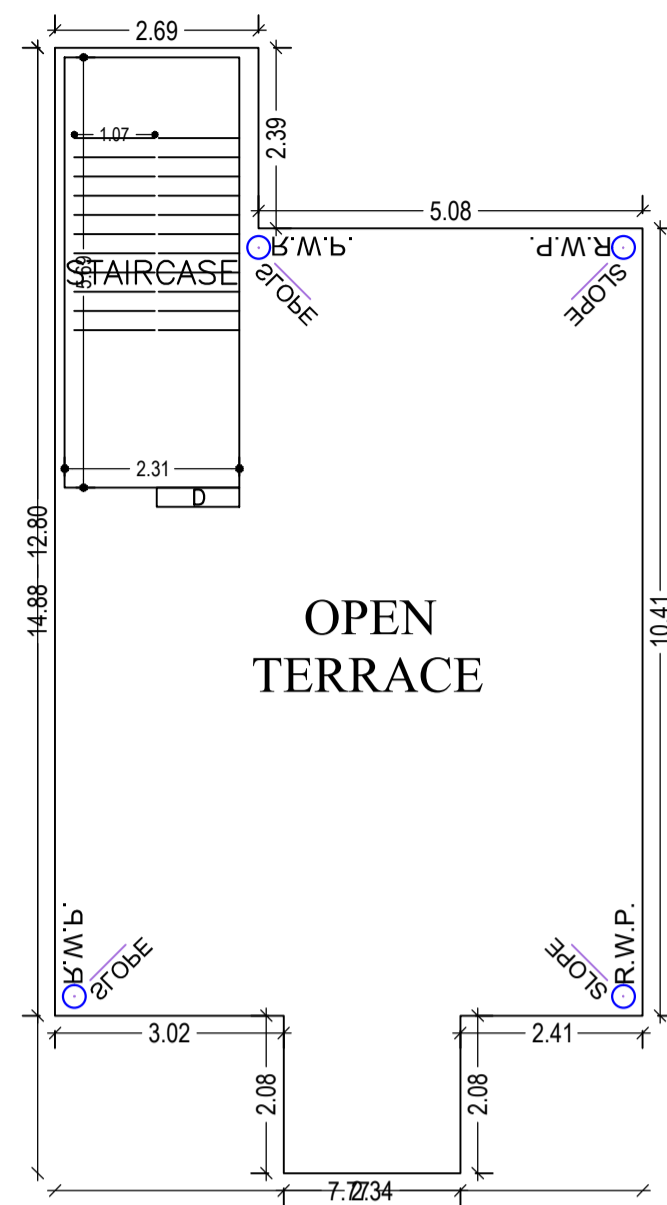

TERRACE FLOOR PLAN (SCALE 1:100)

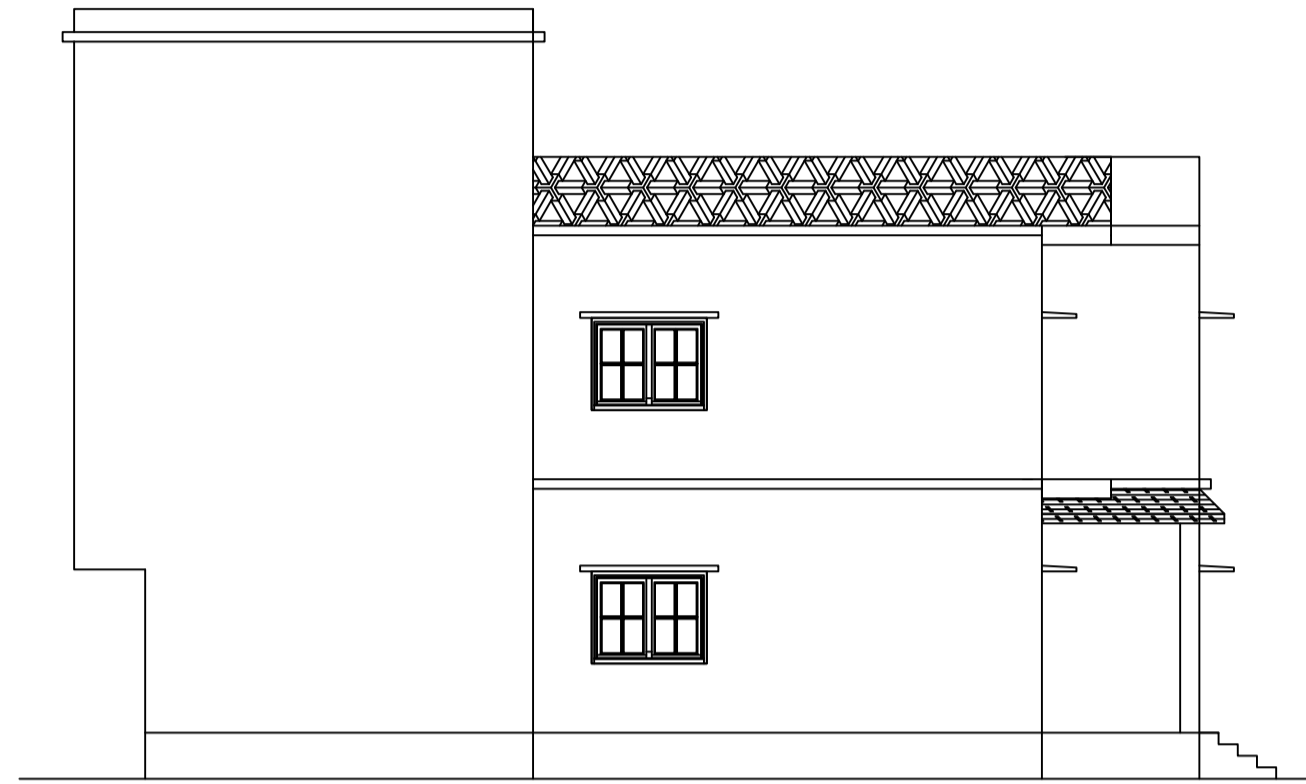

RIGHT SIDE ELEVATION (SCALE 1:100)

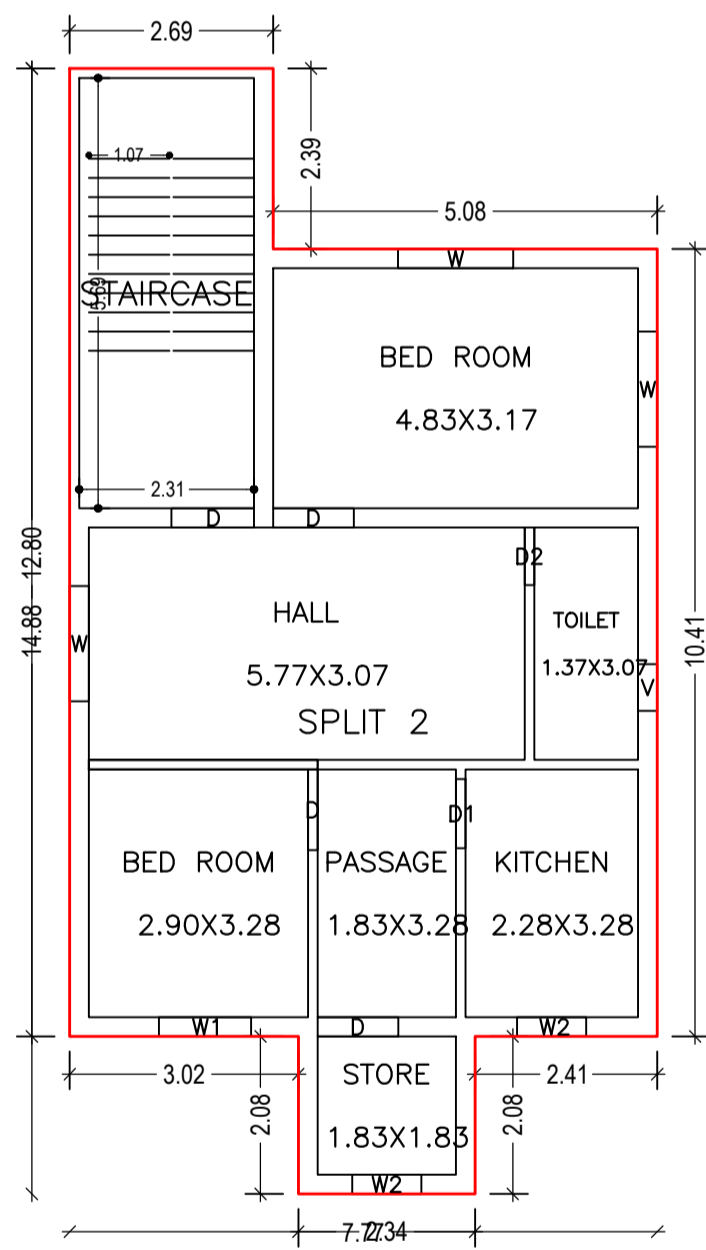

FIRST FLOOR PLAN (Proposed) (SCALE 1:100)

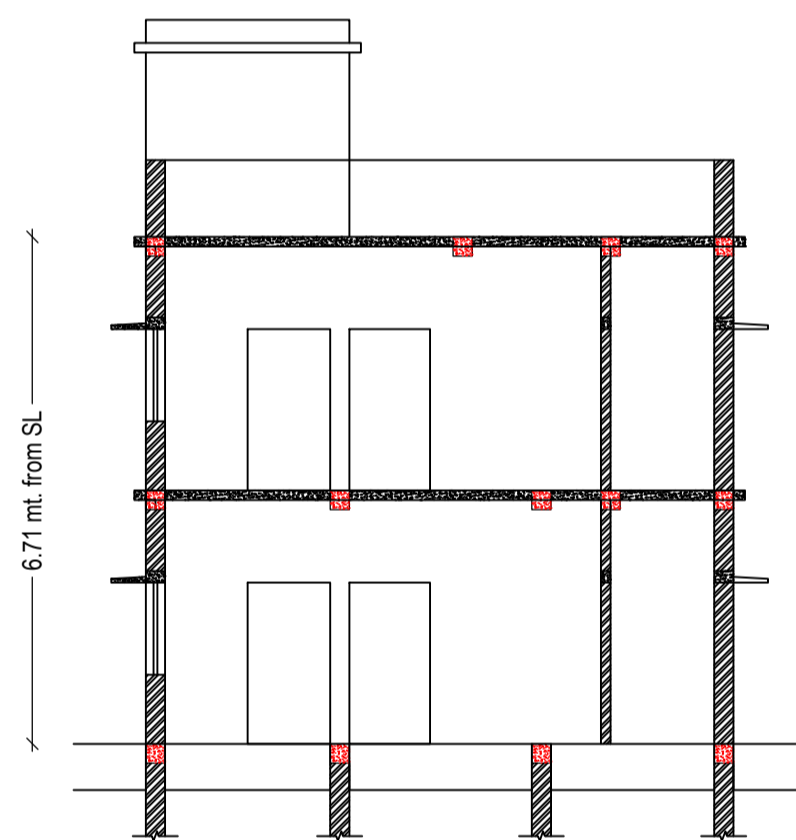

SECTION AT-X-X (SCALE 1:100)

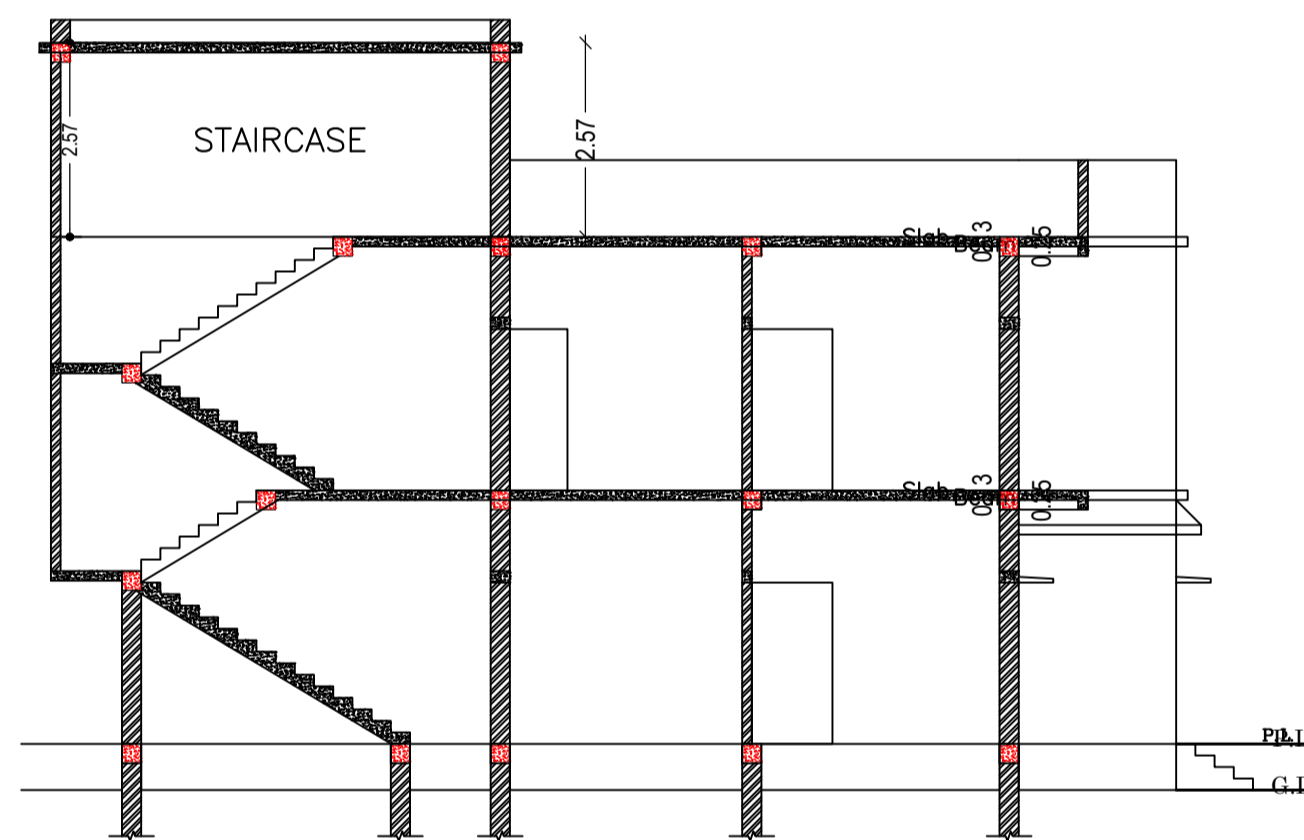

SECTION AT-Y-Y (SCALE 1:100)

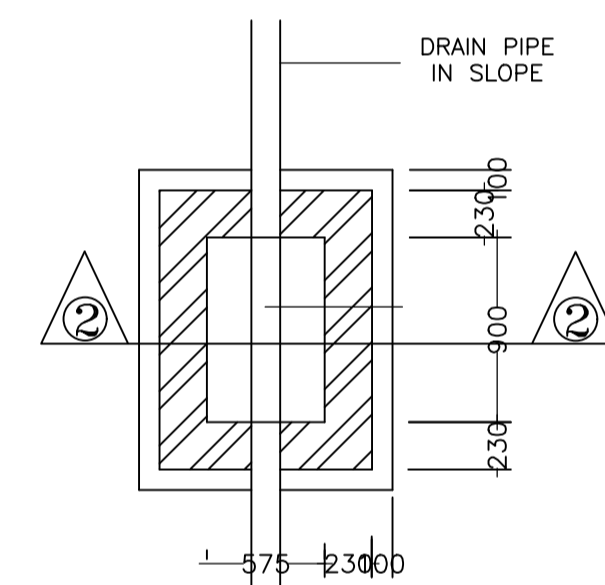
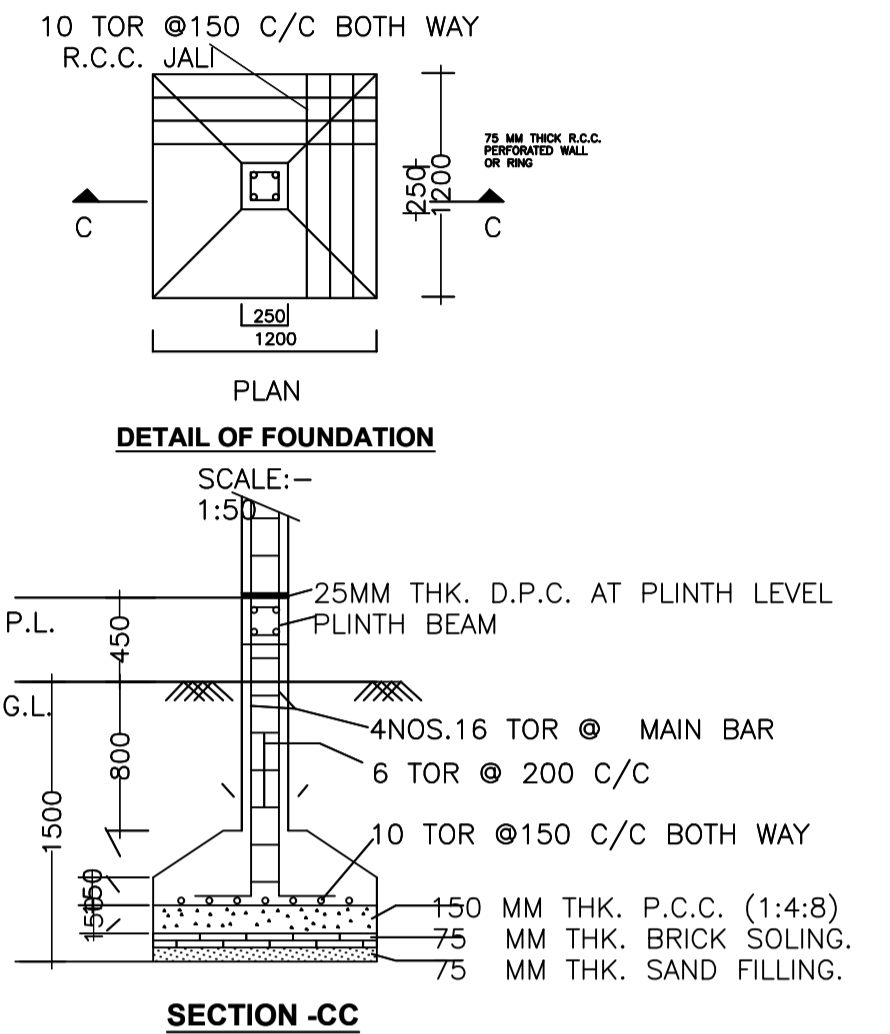
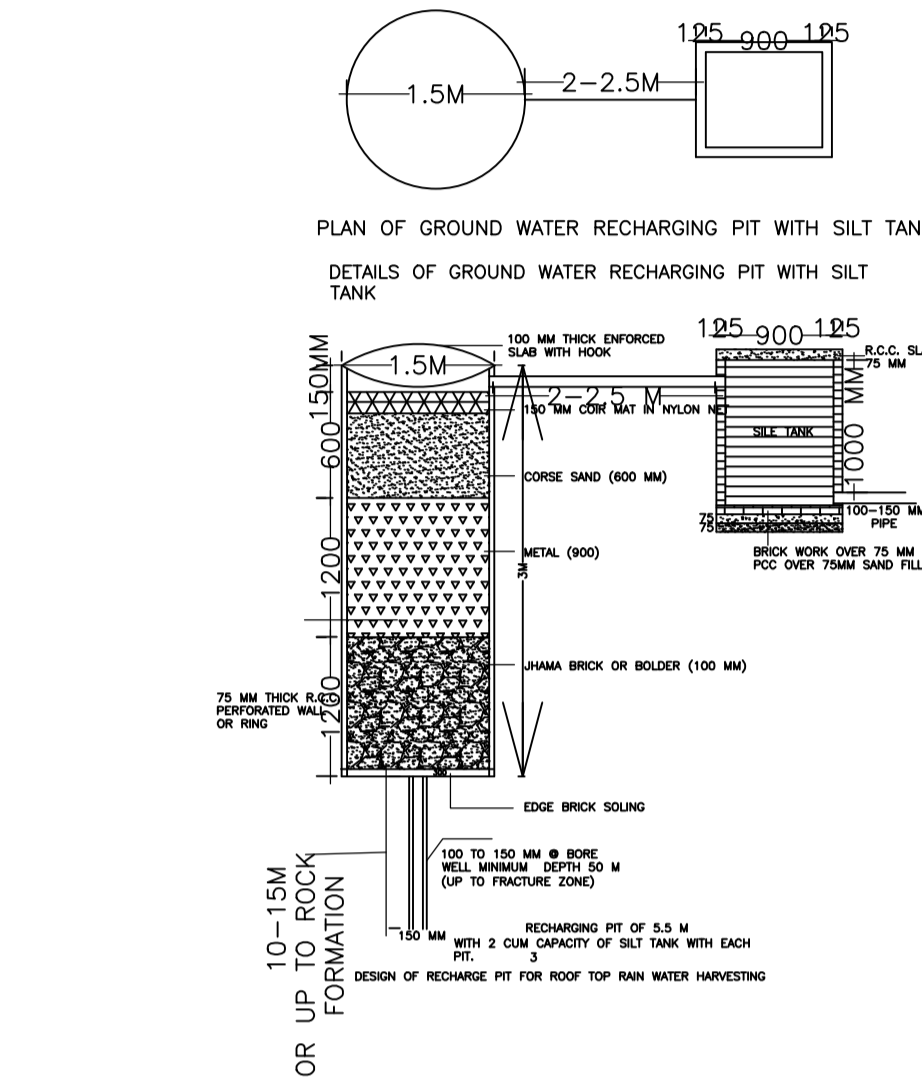

PLAN I.C.DETAILS

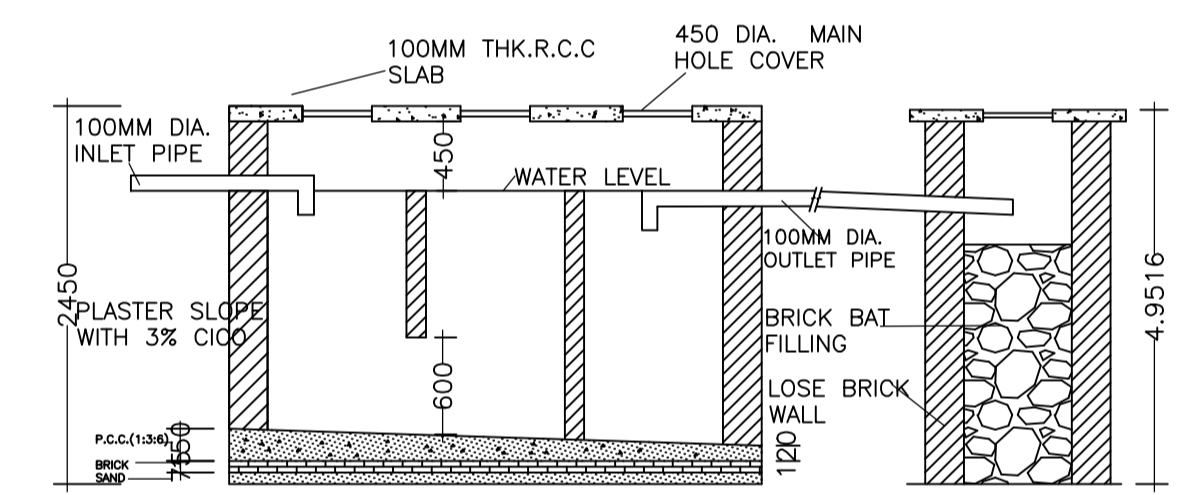

SECTION-DD

R.C.C. COVER

SECTION AT 2-2

DEPTH VARIES AS PER SLOPE

SECTION AT 2-2

SECTION AT 2-2

SECTION AT 2-2

SECTION AT 2-2

SECTION AT 2-2

SECTION AT 2-2

SECTION AT 2-2

SECTION AT 2-2

SECTION AT 2-2

SECTION AT 2-2

SECTION AT 2-2

SECTION AT 2-2

SECTION AT 2-2

SECTION AT 2-2

SECTION AT 2-2

SECTION AT 2-2

SECTION AT 2-2

SECTION AT 2-2

SECTION AT 2-2

SECTION AT 2-2

SECTION AT 2-2

SECTION AT 2-2

SECTION AT 2-2

SECTION AT 2-2

SECTION AT 2-2

SECTION AT 2-2

SECTION AT 2-2

SCHEDULE OF DOOR:

BUILDING NAME	NAME	LENGTH	HEIGHT	NOS
A1 (RESIDENSE)	D2	0.76	2.10	02
A1 (RESIDENSE)	D1	0.91	2.10	02
A1 (RESIDENSE)	D	1.07	2.10	06
A1 (RESIDENSE)	D	1.09	2.10	02
A1 (RESIDENSE)	CG	1.80	2.10	01

SCHEDULE OF WINDOW/VENTILATION:

BUILDING NAME	NAME	LENGTH	HEIGHT	NOS
A1 (RESIDENSE)	V	0.62	1.20	02
A1 (RESIDENSE)	W2	0.91	1.20	03
A1 (RESIDENSE)	W1	1.22	1.20	03
A1 (RESIDENSE)	W	1.52	1.20	06

UnitBUA Table for Building :A1 (RESIDENSE)

FLOOR	Name	UnitBUA Type	UnitBUA Area	Carpet Area	No. of Rooms	No. of Tenement
GROUND FLOOR PLAN	SPLIT 1	FLAT	67.41	67.02	7	1
FIRST FLOOR PLAN	SPLIT 2	FLAT	67.41	67.02	7	1
Total:	-	-	134.82	134.04	14	2



FRONT ELEVATION (SCALE 1:100)

LTP NAME AND SIGNATURE	STRUCTURAL ENG'S NAME AND SIGNATURE	BUILDER NAME AND SIGNATURE	DIGITAL SIGNATURE
RAM RATAN SINGH SINPC/DFTMN/0003/2020			

Proposal Basic Information	
Proposal File No.	SINPC/BP/0255/W02/2021
Owner Name	SMITA TIGGA
Khata No	120
Plot No	4992
Village Name	Gotra
Use	Residential
SubUse	Bungalow/ Dwelling / Non Apartment

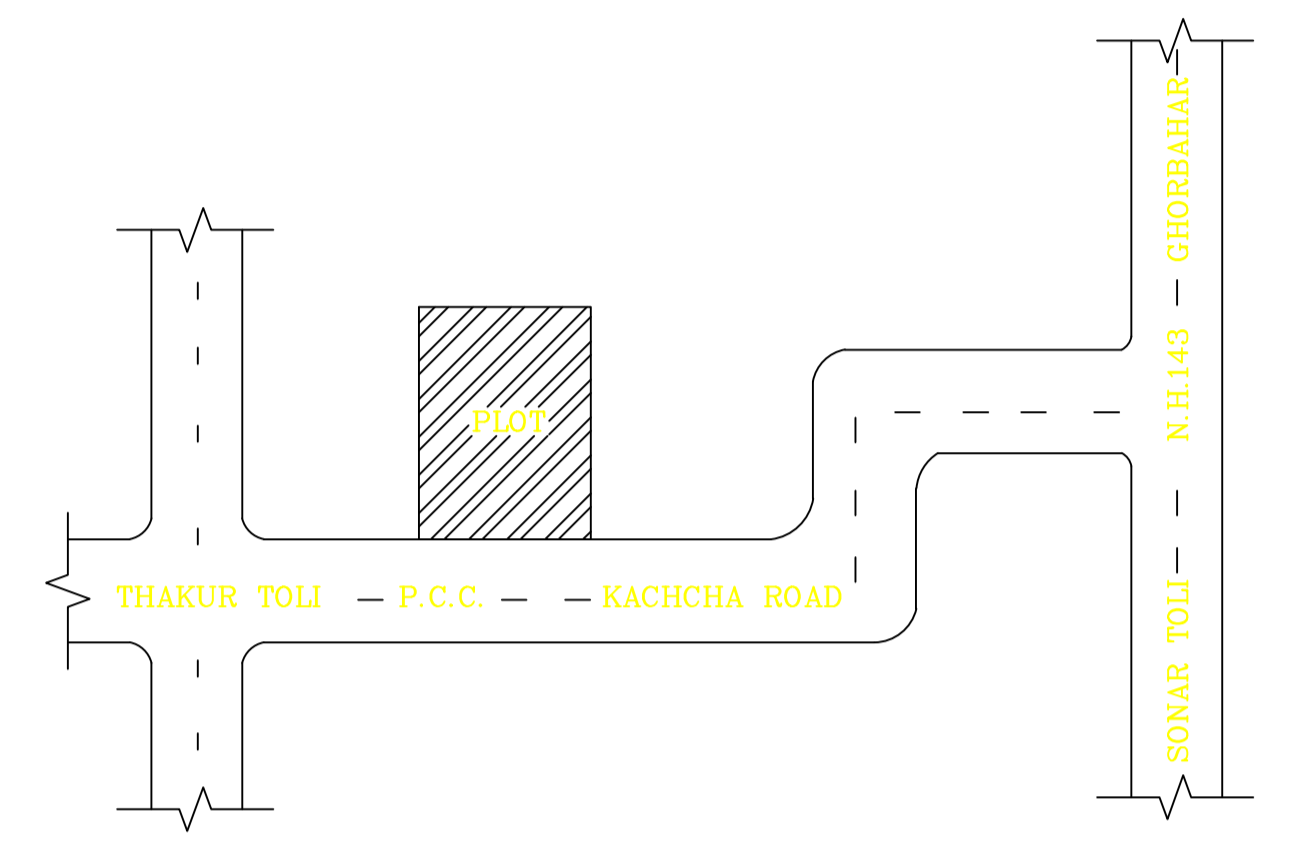
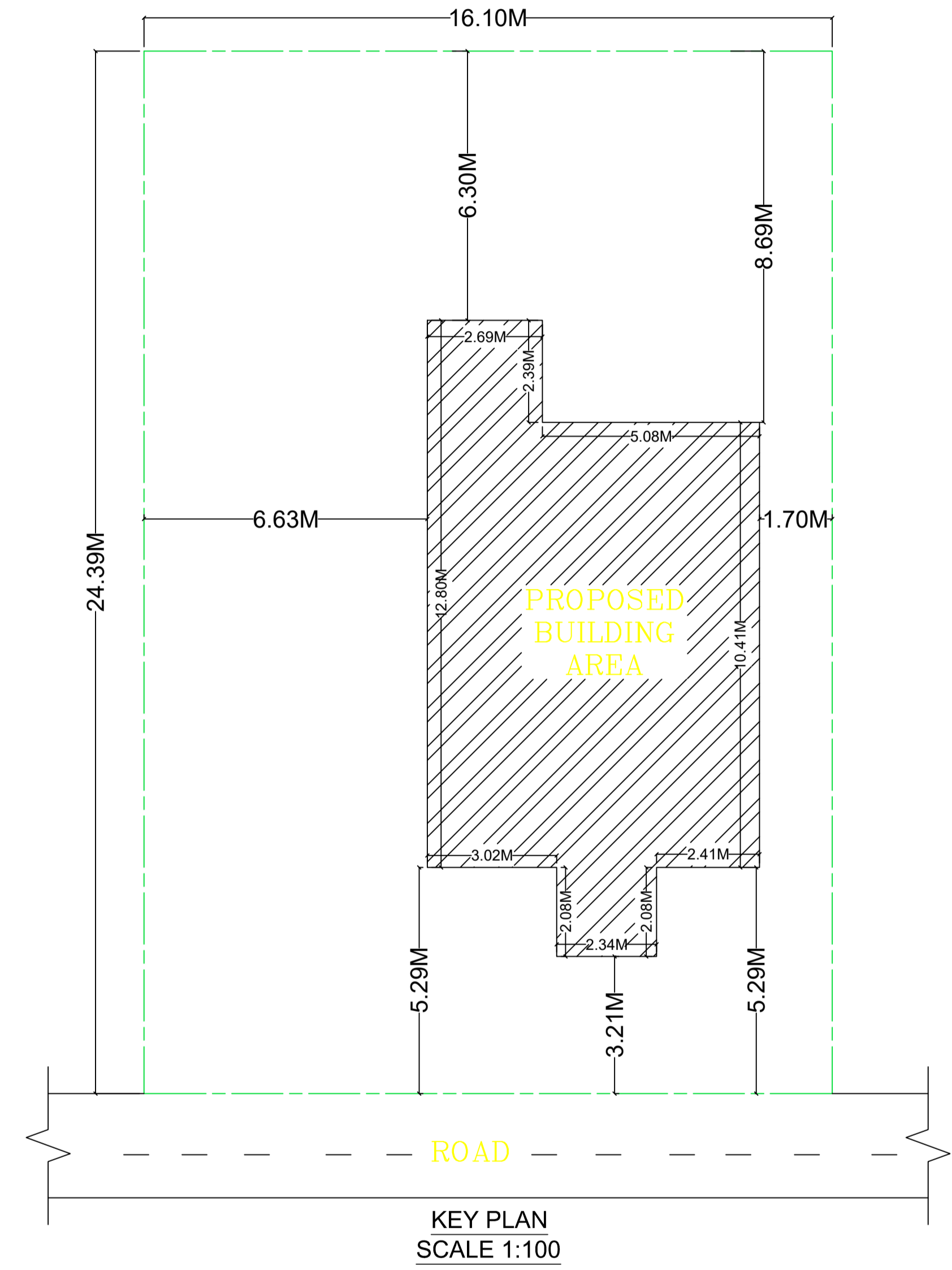

LTP NAME AND SIGNATURE	STRUCTURAL ENG'S NAME AND SIGNATURE	BUILDER NAME AND SIGNATURE	DIGITAL SIGNATURE
RAM RATAN SINGH SINPC/DFTMN/0003/2020			