

SITE PLAN

FAR & Tenement Details (Table 4c-1)

Building	No. of Same Bldg	Total Built Up Area (Sq.mt.)	Proposed FAR Area (Sq.mt.)		Total FAR Area (Sq.mt.)	Total Consumed Additional FAR Area (Sq.mt.)	Trmnt (No.)
			Resi.	Commercial			
A1 (RESI COM)	1	406.86	135.62	271.24	406.86	406.86	03
Grand Total:	1	406.86	135.62	271.24	406.86	406.86	03

Proposal Basic Information

Proposal File No.	SINPC/BP/0328/W05/2022
Owner Name	ALKA MINJ
Khata No	112
Plot No	3296
Village Name	Gotra
Use	Residential
SubUse	ResiComm Bldg

Required Parking (Table 7a)

Building Name	Type	SubUse	Area (Sq.mt.)	Units		Car			Visitors Car			TwoWheeler		
				Reqd.	Prop.	Reqd./Unit	Reqd.	Prop.	Reqd./Unit	Reqd.	Prop.	Reqd./Unit	Reqd.	Prop.
A1 (RESI COM)	Commercial	ResiComm Bldg	> 0	200	249.16	1	1	-	-	-	-	-	-	-
			> 0	200	249.16	-	-	-	-	-	-	1	3	-
A1 (RESI COM)	Residential	ResiComm Bldg	> 0	1	1.00	1	1	-	-	-	-	-	-	-
			> 0	1	1.00	-	-	-	-	-	-	1	1	-
Total:			-	-	-	-	2	-	1	2	-	-	4	

Parking Check (Table 7b)

Vehicle Type	Reqd.		Prop.	
	No.	Area	No.	Area
Car	-	-	2	25.00
Total Car	2	25.00	2	25.00
Visitor's Car Parking	-	-	2	25.00
Total Visitor Parking	1	12.50	2	25.00
TwoWheeler	-	-	2	9.74
Total TwoWheeler	4	8.00	2	9.74
Total		45.50		69.48

AREA STATEMENT SIMDEGA NAGAR PANCHAYAT	VERSION NO: 1.0.62
PROJECT DETAIL:	VERSION DATE: 16/10/2020
Region: JHARKHAND URBAN LOCAL BODIES	Plot Use: Residential
District: SIMDEGA	Plot SubUse: ResiComm Bldg
Authority: SIMDEGA NAGAR PANCHAYAT	PlotNearbyReligiousStructure: NA
Inward No: SINPC/BP/0328/W05/2022	PlotSubPlot No: 3296
Application Type: General Proposal	North: -
Project Type: Building Permission	South: -
Nature of Development: New	East: -
Location of Development Area: Old Area	West: -
AREA DETAILS:	SQ.MT.
AREA OF PLOT (Minimum)	(A) 350.81
NET AREA OF PLOT(Gross Plot Area - Deduction from Gross Plot area)	(A-Deductions) 350.81
Deduction for Balance Plot Area(from Gross Plot Area)	
Common Plot	38.14
Total	38.14
BALANCE AREA OF PLOT(Net Plot Area - Recreational/Amenity space)	(A-Deductions) 312.67
PLOT AREA FOR COVERAGE(Net Plot Area)	(A-Deductions) 350.81
Plot Area for FAR (Net Plot Area + Road Widening Area)	(A-Deductions) 350.81
COVERAGE CHECK	
Permissible Coverage area (60.00 %)	210.49
Proposed Coverage Area (38.66 %)	135.62
Total Prop. Coverage Area (38.66 %)	135.62
Balance coverage area (21.34 %)	74.87
FAR CHECK	
Perm. FAR Area (1.50)	526.21
Total Perm. FAR area	526.21
Residential FAR	135.62
Commercial FAR	271.24
Proposed FAR Area	406.86
Total Proposed FAR Area	406.86
Consumed FAR (Factor)	1.16
Balance FAR Area	119.35
BUILT UP AREA CHECK	
Total Proposed BuiltUp Area	406.86
ARCHITECT (Regd)	RAM RATAN SINGH
ENGINEER (Regd)	
SUPERVISOR (Regd)	
OWNER (Regd)	ALKA MINJ
DEVELOPMENT AUTHORITY	LOCAL BODY

COLOR INDEX	
PLOT BOUNDARY	Black
ABUTTING ROAD	Green
PROPOSED CONSTRUCTION	Red
COMMON PLOT	Yellow
ROAD WIDENING AREA	Orange
EXISTING (To be retained)	Blue
EXISTING (To be demolished)	White

Buildingwise Floor FAR Details

Floor Name	Building Name		Total	
	Proposed Built Up Area (Sq.mt.)	Proposed FAR Area (Sq.mt.)	Total Proposed Built Up Area (Sq.mt.)	Total FAR Area (Sq.mt.)
Ground Floor	135.62	135.62	135.62	135.62
First Floor	135.62	135.62	135.62	135.62
Second Floor	135.62	135.62	135.62	135.62
Terrace Floor	0.00	0.00	0.00	0.00
Total:	406.86	406.86	406.86	406.86

Building USE/SUBUSE Details

Building Name	Building Use	Building SubUse	Building Structure
A1 (RESI COM)	Commercial	ResiComm Bldg	Non-Highrise

LTP NAME AND SIGNATURE	STRUCTURAL ENG'S NAME AND SIGNATURE	BUILDER NAME AND SIGNATURE	DIGITAL SIGNATURE
RAM RATAN SINGH SINPC/DFTMN/0003/2020			

Proposal Basic Information

Proposal File No.	SINPC/BP/0328/W05/2022
Owner Name	ALKA MINJ
Khata No	112
Plot No	3296
Village Name	Gotra
Use	Residential
SubUse	ResiComm Bldg

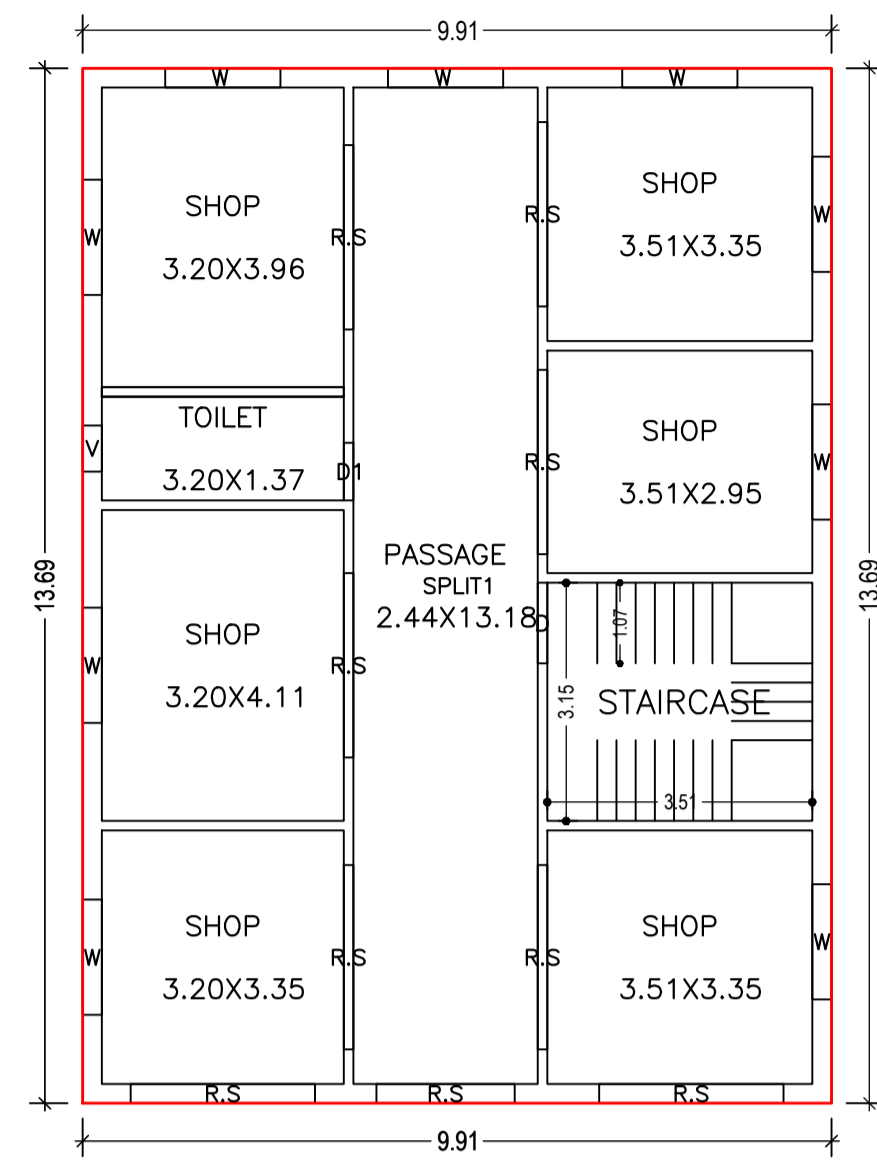

GROUND FLOOR PLAN
(Proposed)
(SCALE 1:100)

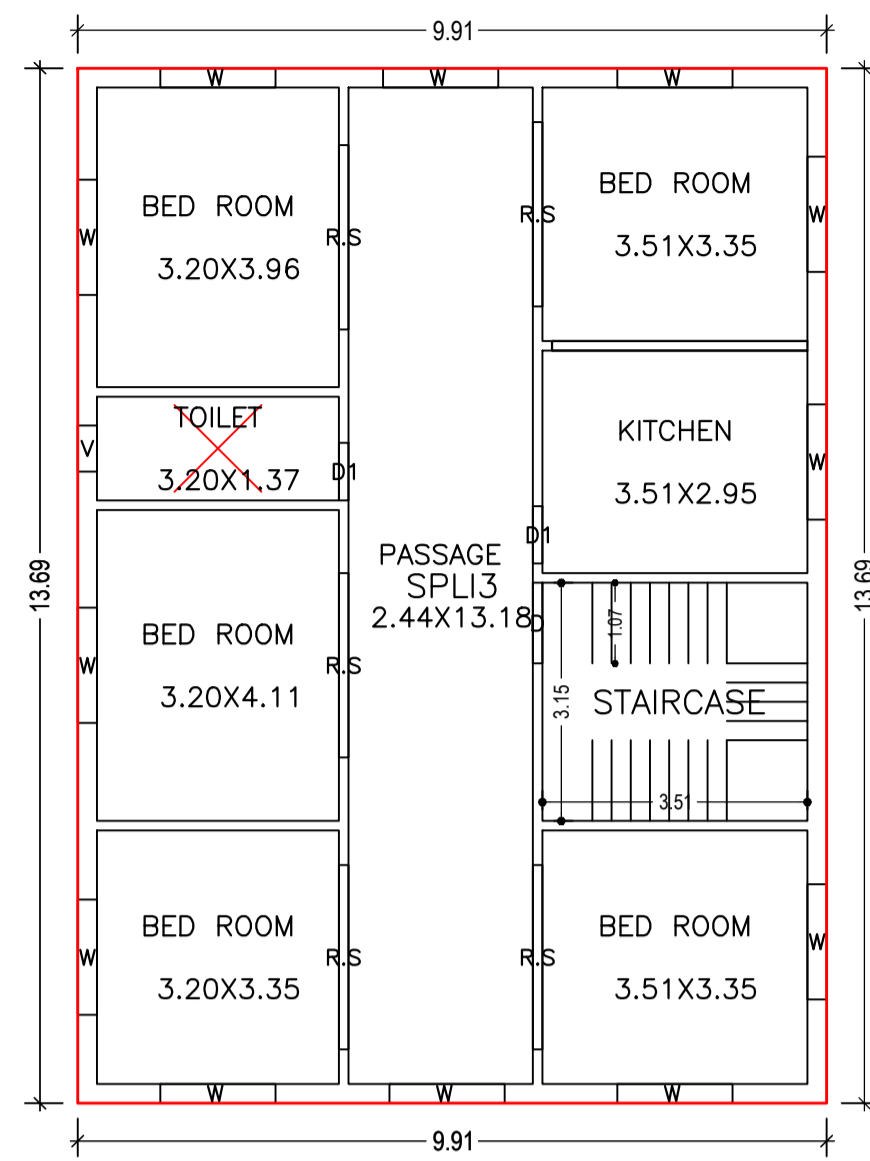

SECOND FLOOR PLAN
(Proposed)
(SCALE 1:100)

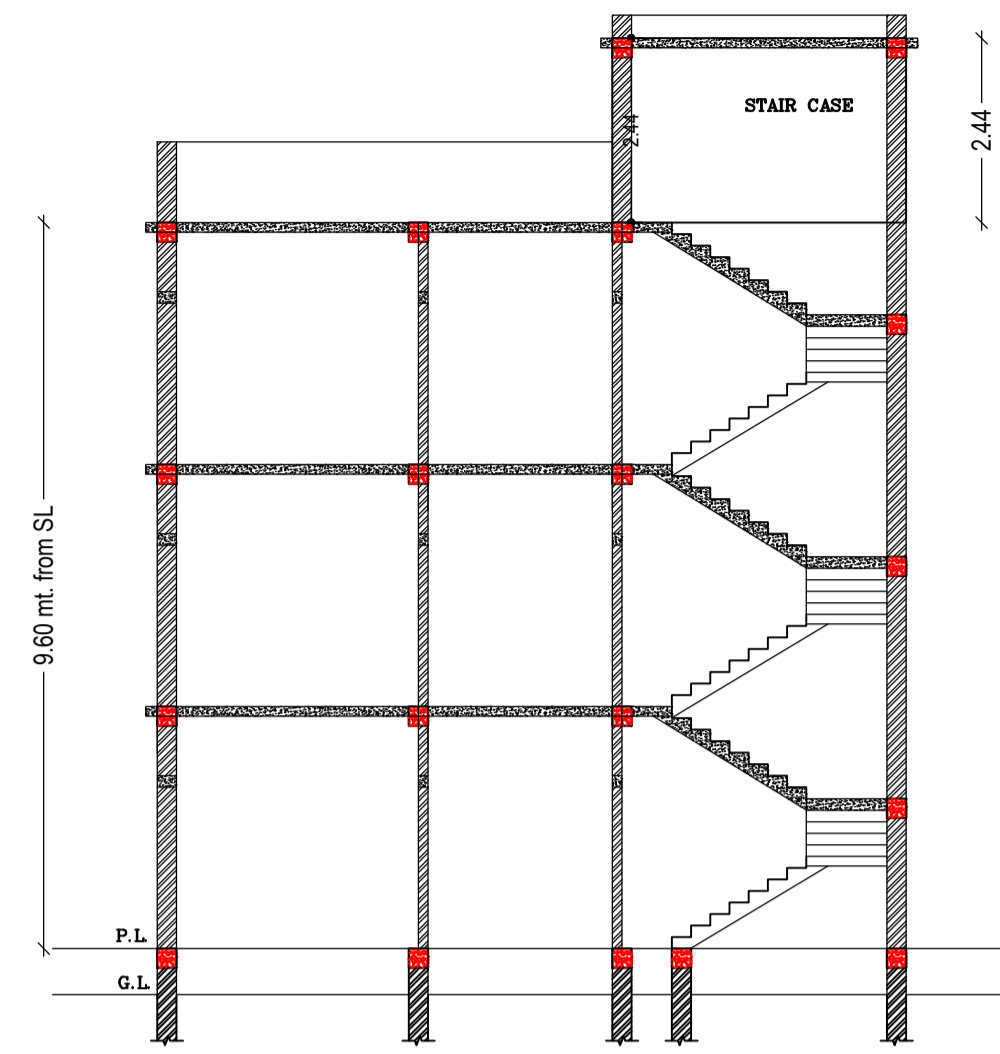

SECTION AT: X-X
SCALE 1:100

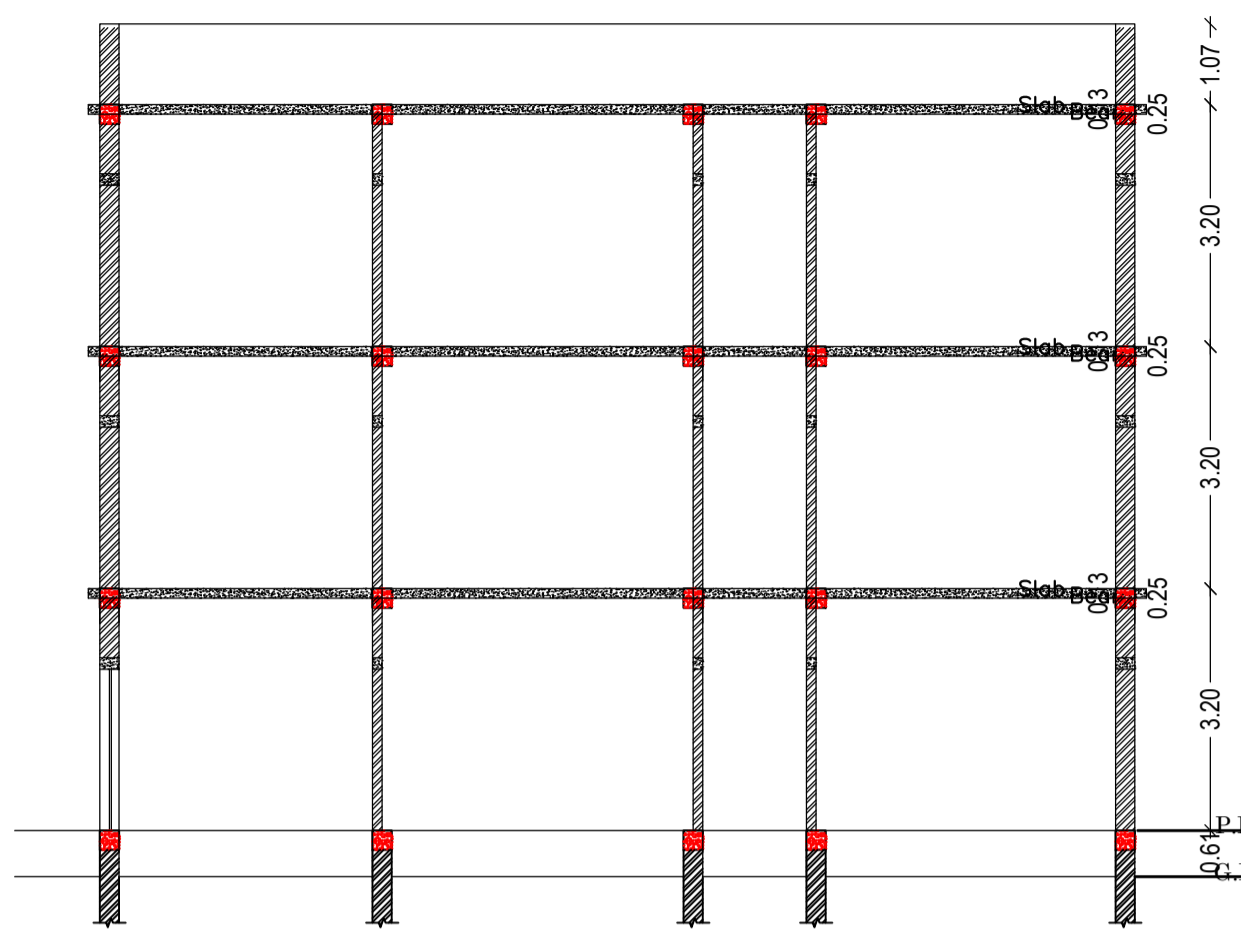

SECTION AT: Y-Y
SCALE 1:100

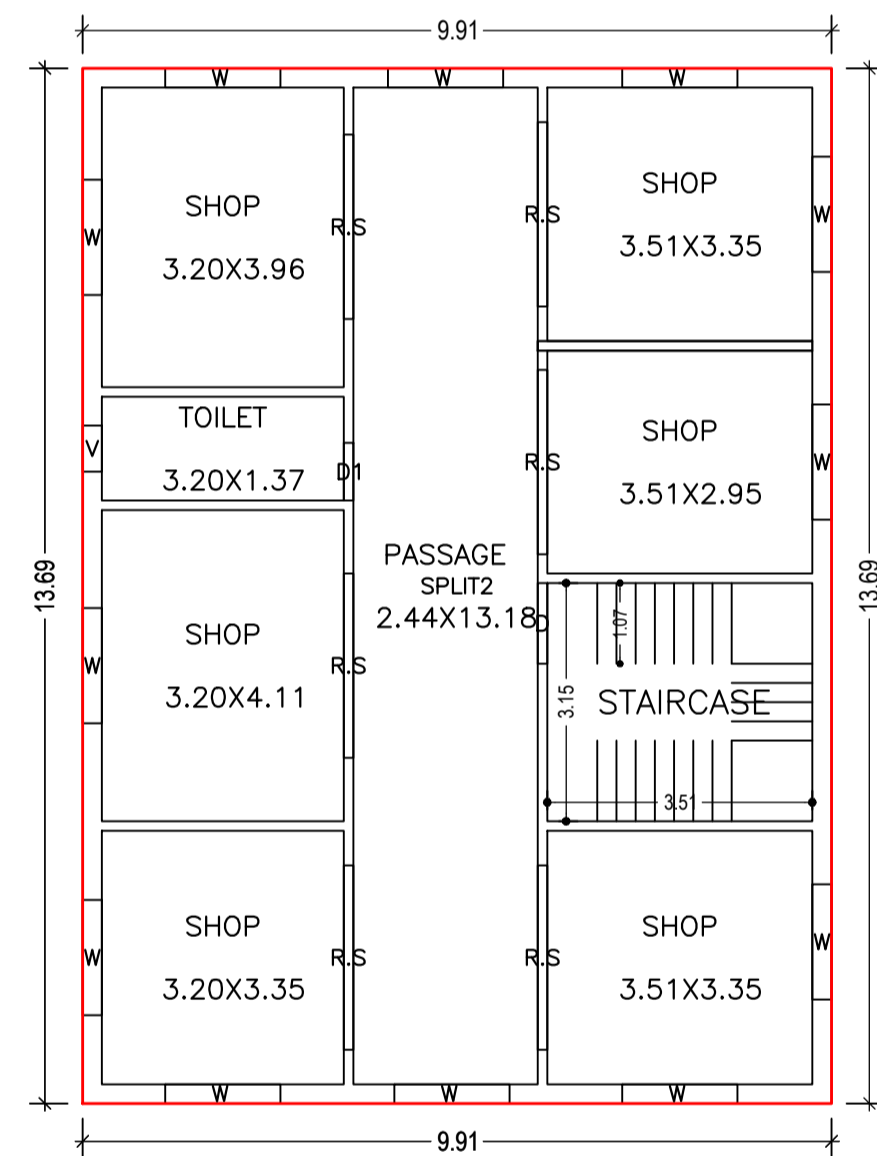
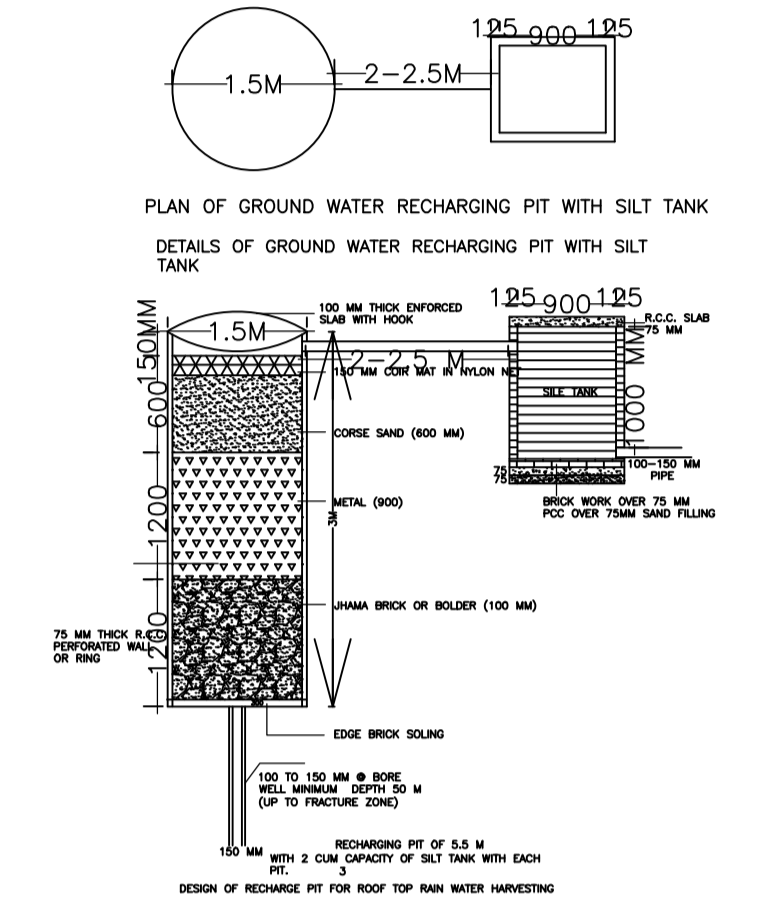

FIRST FLOOR PLAN
(Proposed)
(SCALE 1:100)

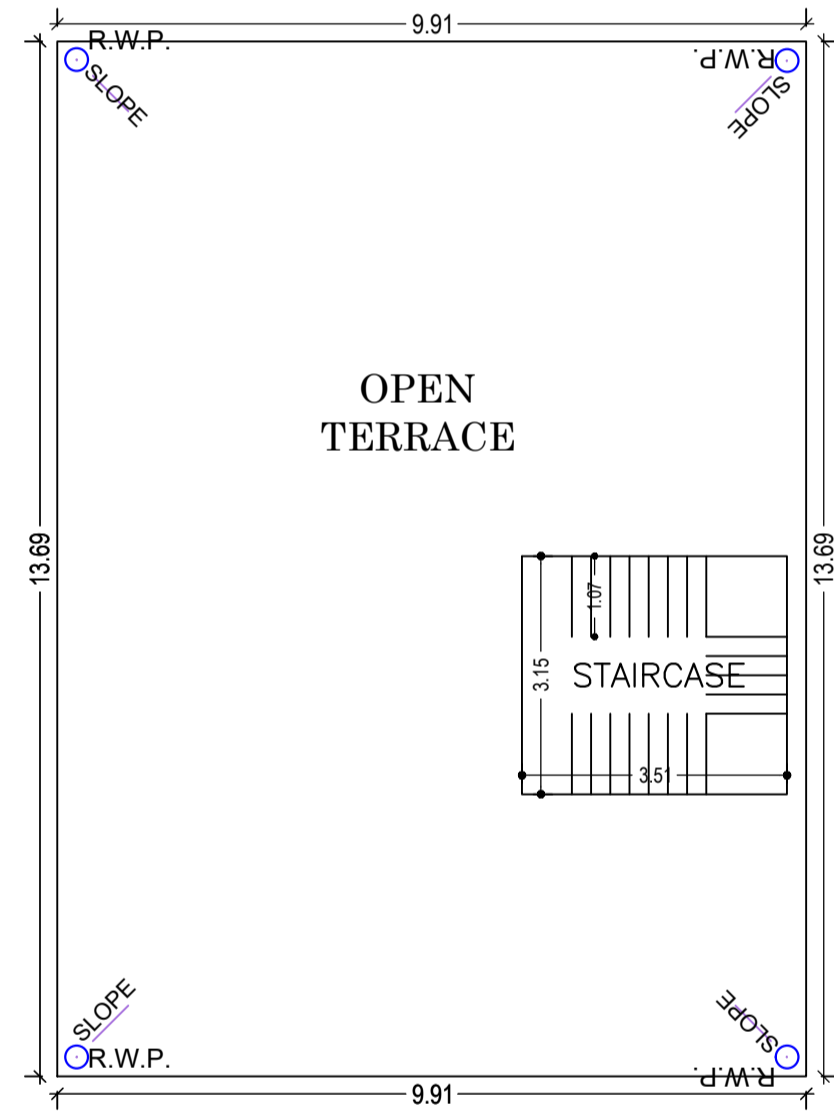

TERRACE FLOOR PLAN
(SCALE 1:100)

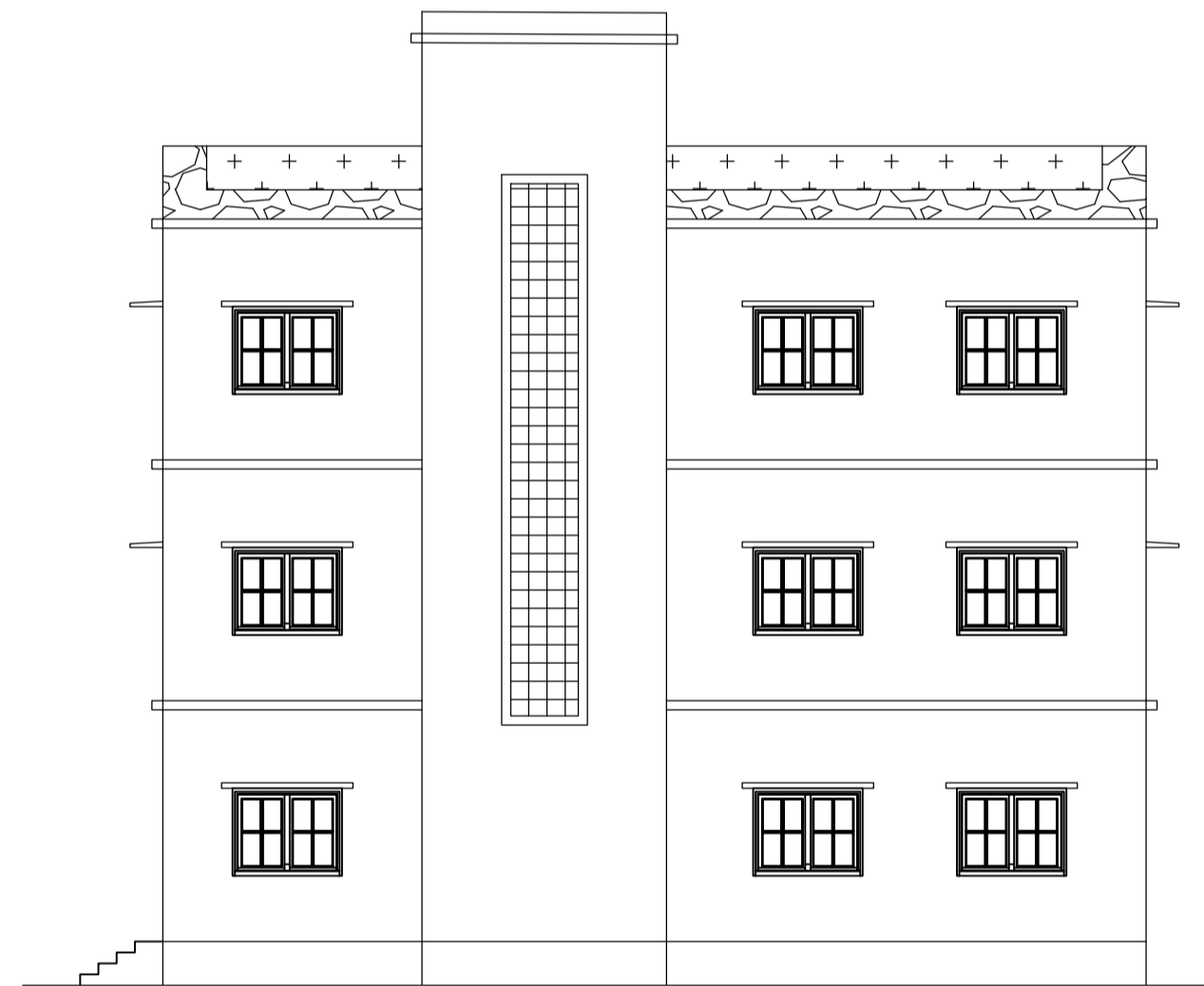

RIGHT SIDE ELEVATION
SCALE 1:100

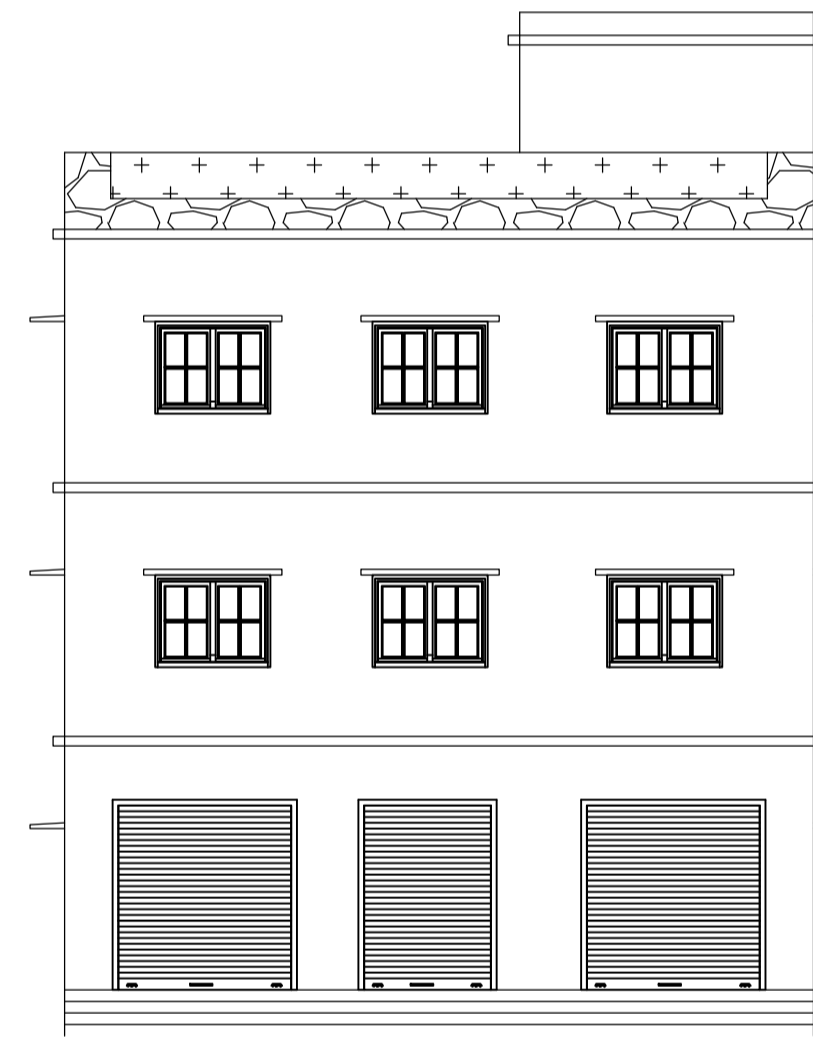

FRONT ELEVATION
SCALE 1:100

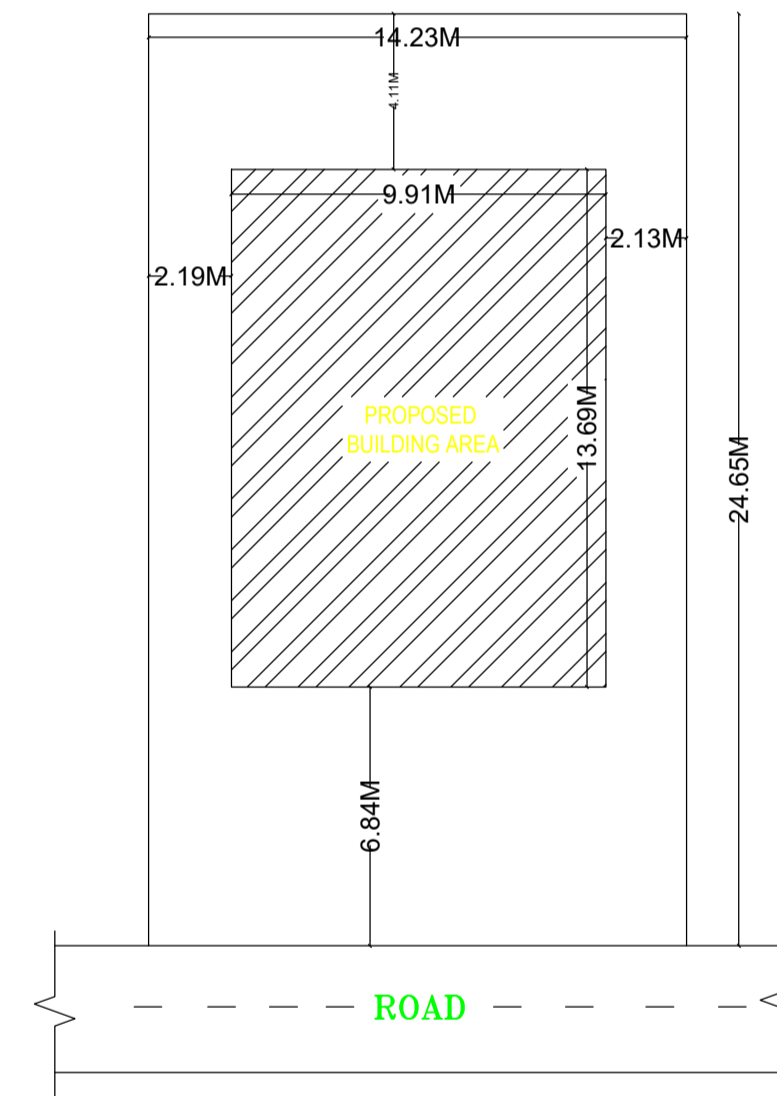

KEY PLAN
SCALE 1:200

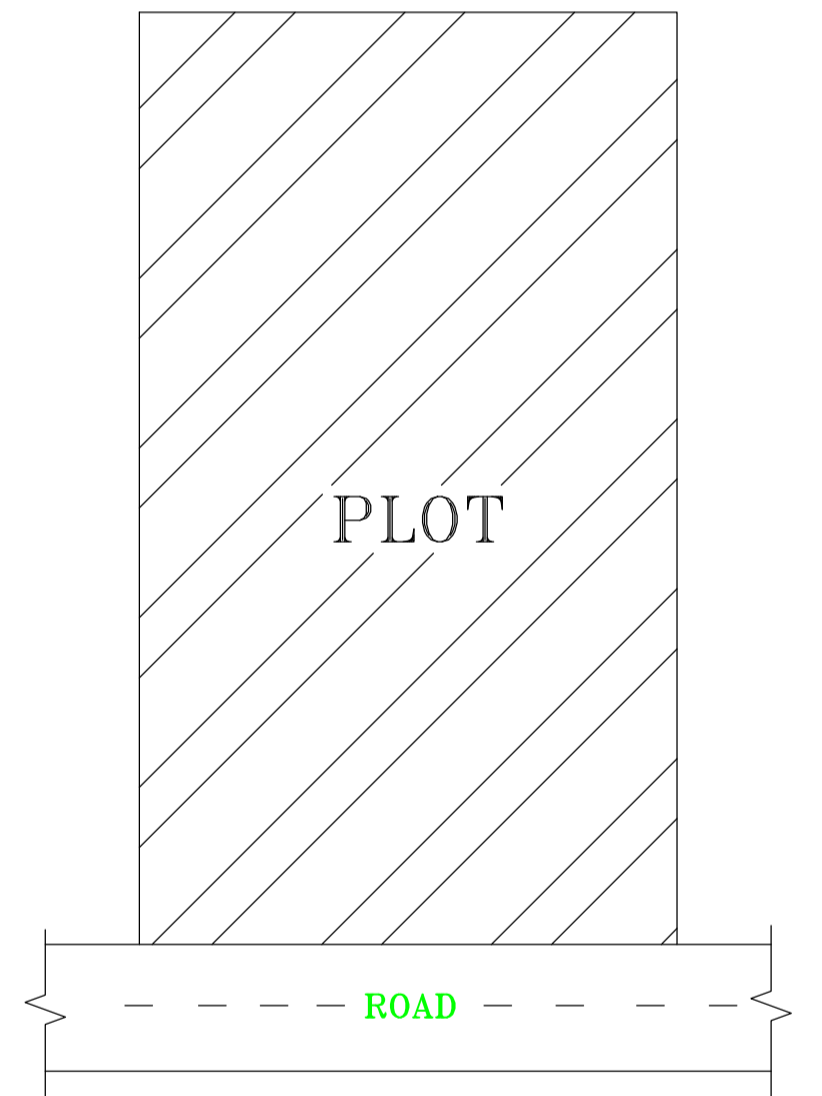

LOCATION PLAN
NOT TO SCALE

Building :A1 (RESI COM)

Floor Name	Total Built Up Area (Sq.mt.)	Proposed FAR Area (Sq.mt.)		Total FAR Area (Sq.mt.)	Total Consumed Additional FAR Area (Sq.mt.)	Tnmt (No.)
		Resi.	Commercial			
Ground Floor	135.62	0.00	135.62	135.62	135.62	01
First Floor	135.62	0.00	135.62	135.62	135.62	01
Second Floor	135.62	135.62	0.00	135.62	135.62	01
Terrace Floor	0.00	0.00	0.00	0.00	0.00	00
Total :	406.86	135.62	271.24	406.86	406.86	03
Total Number of Same Buildings	1					
Total :	406.86	135.62	271.24	406.86	406.86	03

SCHEDULE OF DOOR:

BUILDING NAME	NAME	LENGTH	HEIGHT	NOS
A1 (RESI COM)	V	0.61	2.10	03
A1 (RESI COM)	D1	0.76	2.10	04
A1 (RESI COM)	R.S	2.44	2.10	19

SCHEDULE OF WINDOW/VENTILATION:

BUILDING NAME	NAME	LENGTH	HEIGHT	NOS
A1 (RESI COM)	D	1.07	1.20	03
A1 (RESI COM)	W	1.52	1.20	33
A1 (RESI COM)	R.S	1.83	1.20	01

UnitBUA Table for Building :A1 (RESI COM)

FLOOR	Name	UnitBUA Type	UnitBUA Area	Carpet Area	No. of Rooms	No. of Tenement
GROUND FLOOR PLAN	SPLIT1	SHOP	111.53	111.12	8	1
FIRST FLOOR PLAN	SPLIT2	SHOP	111.53	111.07	8	1
SECOND FLOOR PLAN	SPLI3	FLAT	111.53	111.10	8	1
Total:	-	-	334.59	333.29	24	3

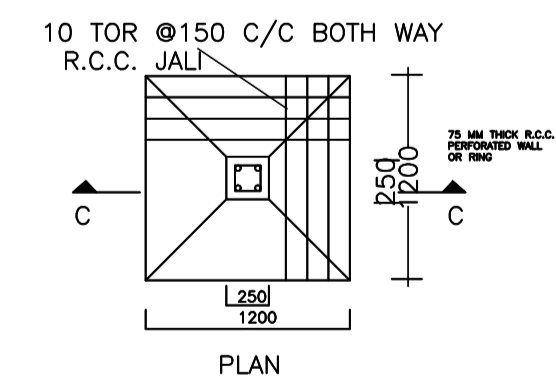

DETAIL OF FOUNDATION

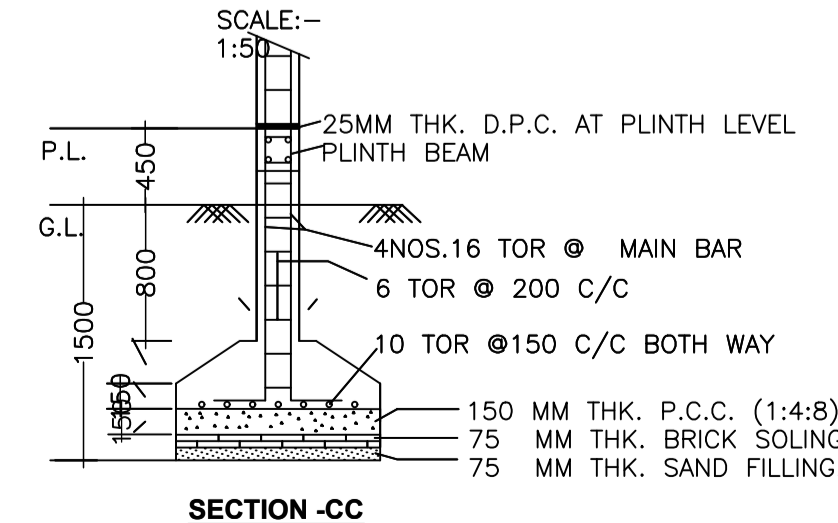

SECTION -CC

LTP NAME AND SIGNATURE	STRUCTURAL ENG'S NAME AND SIGNATURE	BUILDER NAME AND SIGNATURE	DIGITAL SIGNATURE
RAM RATAN SINGH SINPC/DFTMN/0003/2020			

Proposal Basic Information

Proposal File No.	SINPC/BP/0328/W05/2022
Owner Name	ALKA MINJ
Khata No	112
Plot No	3296
Village Name	Gotra
Use	Residential
SubUse	ResiComm Bldg

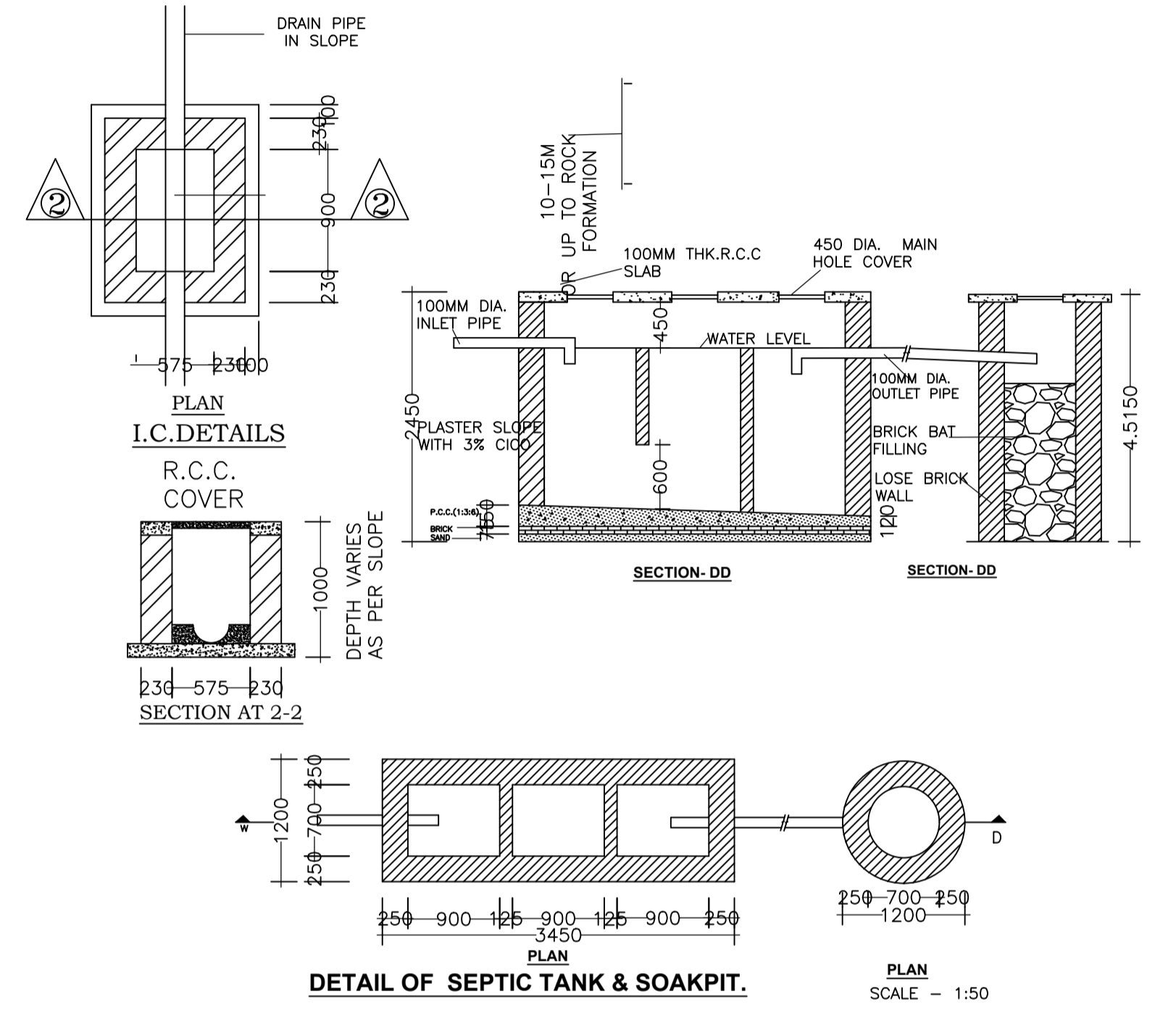

LTP NAME AND SIGNATURE	STRUCTURAL ENG'S NAME AND SIGNATURE	BUILDER NAME AND SIGNATURE	DIGITAL SIGNATURE
RAM RATAN SINGH SINPC/DFTMN/0003/2020			