

# SITE PLAN

FAR & Tenement Details (Table 4c-1)

Building	No. of Same Bldg	Total Built Up Area (Sq.mt.)	Proposed FAR Area (Sq.mt.) Resi.	Total FAR Area (Sq.mt.)	Total Consumed Additional FAR Area (Sq.mt.)	Tnmt (No.)
A (RESIDENCE)	1	207.87	207.87	207.87	207.87	01
Grand Total	1	207.87	207.87	207.87	207.87	01

Proposal Basic Information

Proposal File No.	SINPC/BP/0370/W03/2022
Owner Name	MANJU MINZ
Khata No	06
Plot No	1135
Village Name	Saldega
Use	Residential
SubUse	Bungalow/ Dwelling / Non Apartment

AREA STATEMENT SIMDEGA NAGAR PANCHAYAT	VERSION NO: 1.0.66	VERSION DATE: 16/10/2020
PROJECT DETAIL:		
Region: JHARKHAND URBAN LOCAL BODIES	Plot Use: Residential	
District: SIMDEGA	Plot SubUse: Bungalow/ Dwelling / Non Apartment	
Authority: SIMDEGA NAGAR PANCHAYAT	PlotNearbyReligiousStructure: NA	
Inward No: SINPC/BP/0370/W03/2022	PlotSubPlot No: 1135	
Application Type: General Proposal	North: -	
Project Type: Building Permission	South: -	
Nature of Development: New	East: -	
Location of Development Area: Old Area	West: -	
AREA DETAILS:		
AREA OF PLOT (Minimum)	(A)	SQ.MT. 201.46
Deduction for NetPlot Area		
Surrender Free of Cost		21.90
Total		21.90
NET AREA OF PLOT(Gross Plot Area - Deduction from Gross Plot area)	(A-Deductions)	179.56
Deduction for Balance Plot Area(from Gross Plot Area)		
Surrender Free of Cost		21.90
Common Plot		13.65
Total		35.55
BALANCE AREA OF PLOT(Net Plot Area - Recreational/Amenity space)	(A-Deductions)	165.91
PLOT AREA FOR COVERAGE(Net Plot Area)	(A-Deductions)	179.56
Plot Area for FAR (Net Plot Area + RoadWidening Area)	(A-Deductions)	201.46
COVERAGE CHECK		
Permissible Coverage area ( 70.00 % )		125.69
Proposed Coverage Area ( 54.76 % )		98.33
Total Prop. Coverage Area ( 54.76 % )		98.33
Balance coverage area ( 15.24 % )		27.36
FAR CHECK		
Perm. FAR Area ( 1.500 )		302.19
Total Perm. FAR area		302.19
Residential FAR		207.87
Proposed FAR Area		207.87
Total Proposed FAR Area		207.87
Consumed FAR (Factor)		1.03
Balance FAR Area		94.32
BUILT UP AREA CHECK		
Total Proposed BuiltUp Area		207.87
ARCHITECT (Regd)	MAHENDRA MEHTA	
ENGINEER (Regd)		
SUPERVISOR (Regd)		
OWNER (Regd)	MANJU MINZ	
DEVELOPMENT AUTHORITY		LOCAL BODY

COLOR INDEX	
PLOT BOUNDARY	Black
ABUTTING ROAD	Green
PROPOSED CONSTRUCTION	Red
COMMON PLOT	Yellow
ROAD WIDENING AREA	Orange
EXISTING (To be retained)	Blue
EXISTING (To be demolished)	Light Blue

Buildingwise Floor FAR Details

Floor Name	Building Name A (RESIDENCE)		Total	
	Proposed Built Up Area (Sq.mt.)	Proposed FAR Area (Sq.mt.)	Total Proposed Built Up Area (Sq.mt.)	Total FAR Area (Sq.mt.)
Ground Floor	98.33	98.33	98.33	98.33
First Floor	109.54	109.54	109.54	109.54
Terrace Floor	0.00	0.00	0.00	0.00
Total	207.87	207.87	207.87	207.87

Building USE/SUBUSE Details

Building Name	Building Use	Building SubUse	Building Structure
A (RESIDENCE)	Residential	Bungalow/ Dwelling / Non Apartment	Non-Highrise

LTP NAME AND SIGNATURE	STRUCTURAL ENG'S NAME AND SIGNATURE	BUILDER NAME AND SIGNATURE	DIGITAL SIGNATURE
MAHENDRA MEHTA SINPC/DFTMN/0002/2022			

Proposal File No.	SINPC/BP/0370/W03/2022
Owner Name	MANJU MINZ
Khata No	06
Plot No	1135
Village Name	Saldega
Use	Residential
SubUse	Bungalow/ Dwelling / Non Apartment

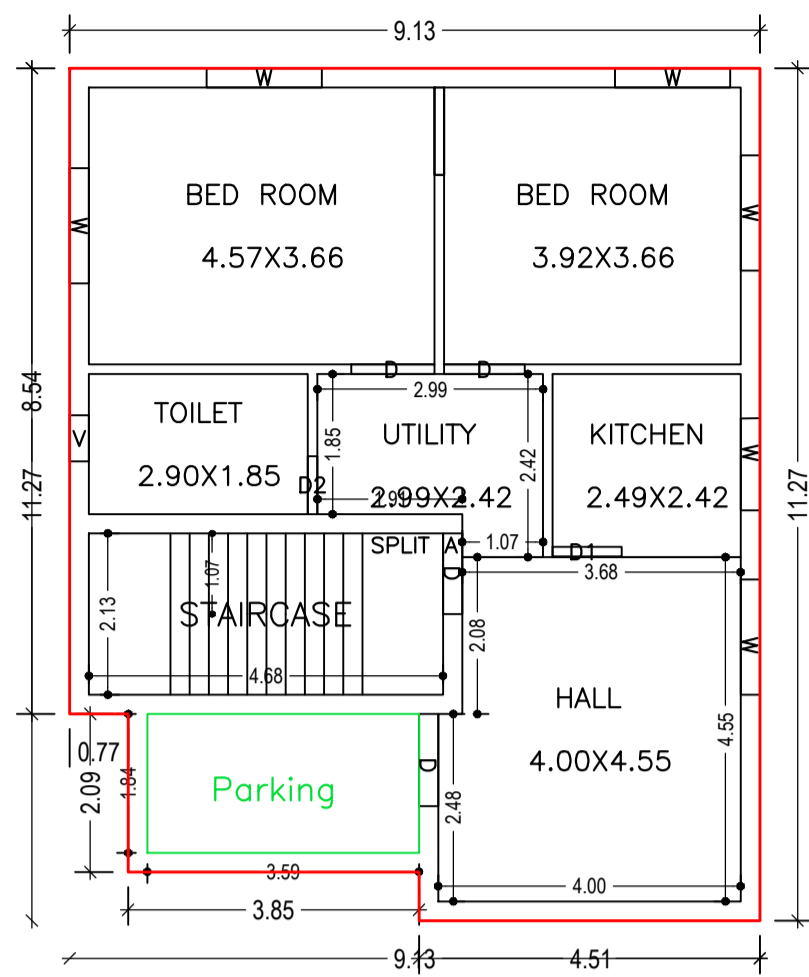

GROUND FLOOR PLAN (Proposed) (SCALE 1:100)

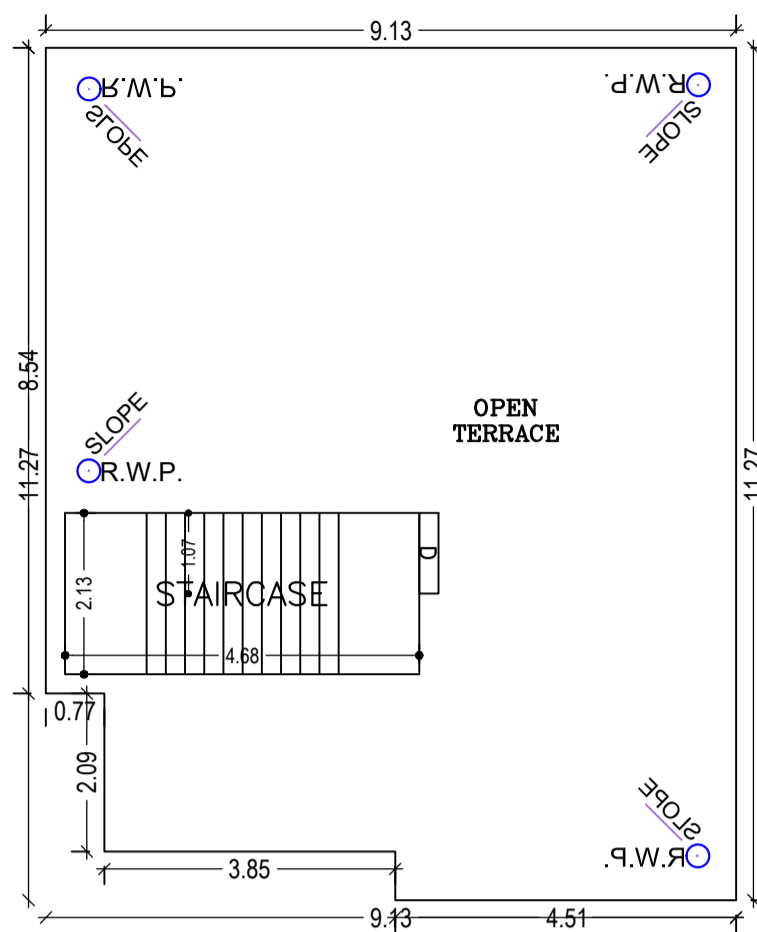

TERRACE FLOOR PLAN (SCALE 1:100)

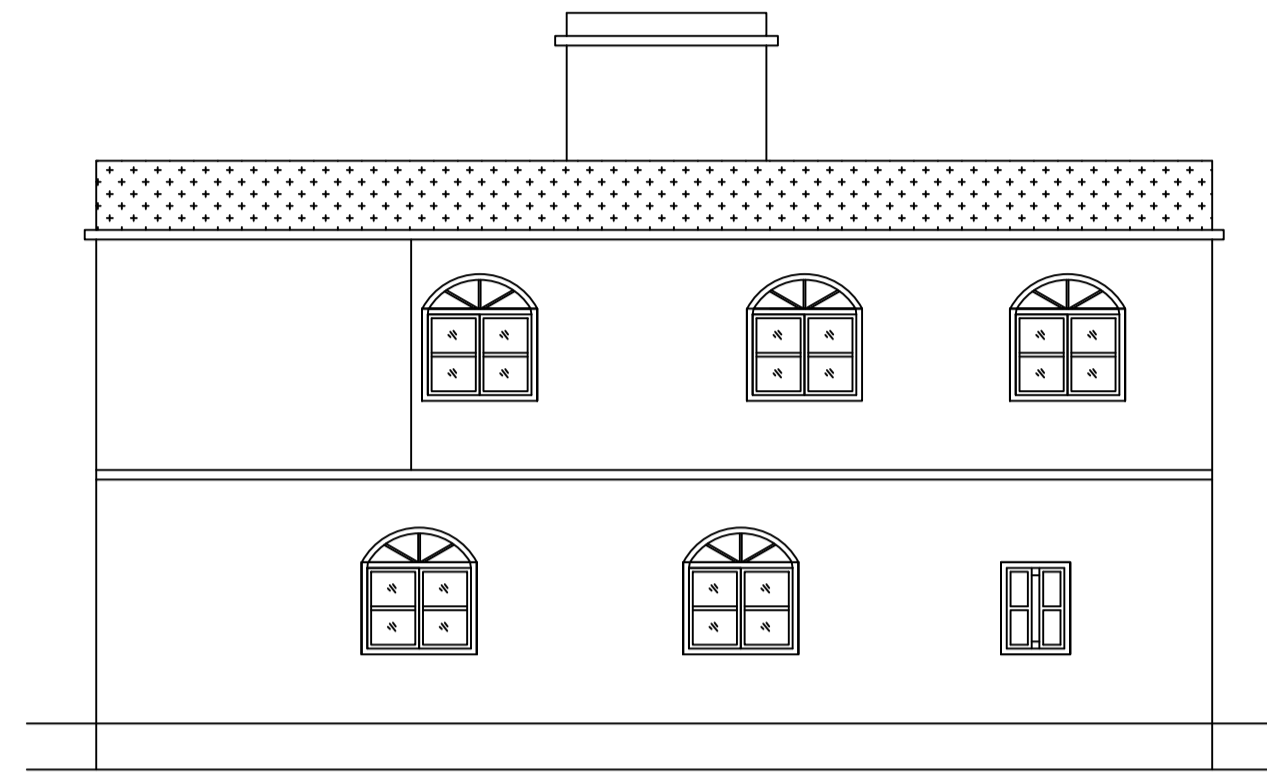

RIGHT SIDE ELEVATION (SCALE 1:100)

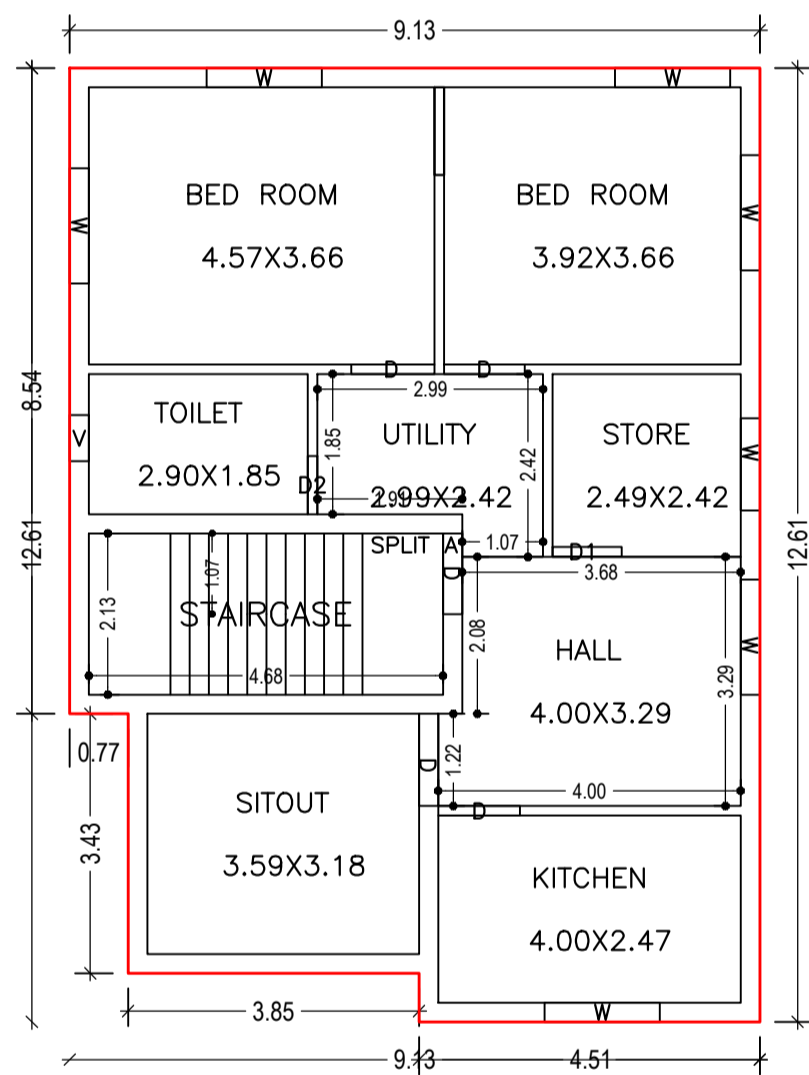

FIRST FLOOR PLAN (Proposed) (SCALE 1:100)

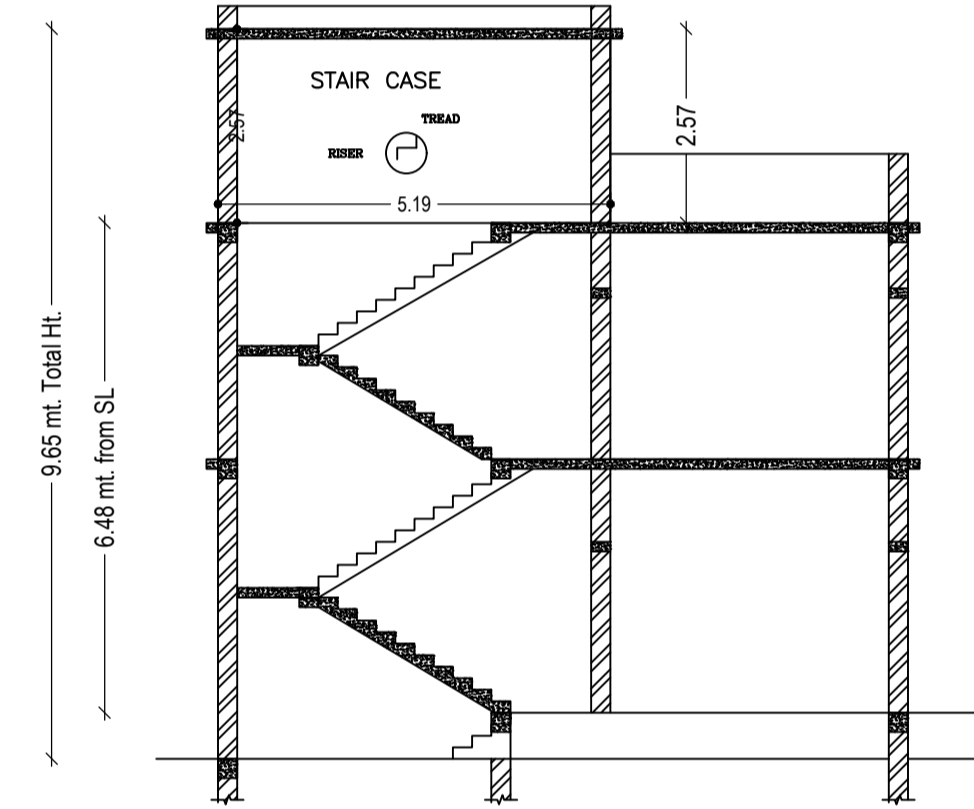

SECTION ON (SCALE 1:100)

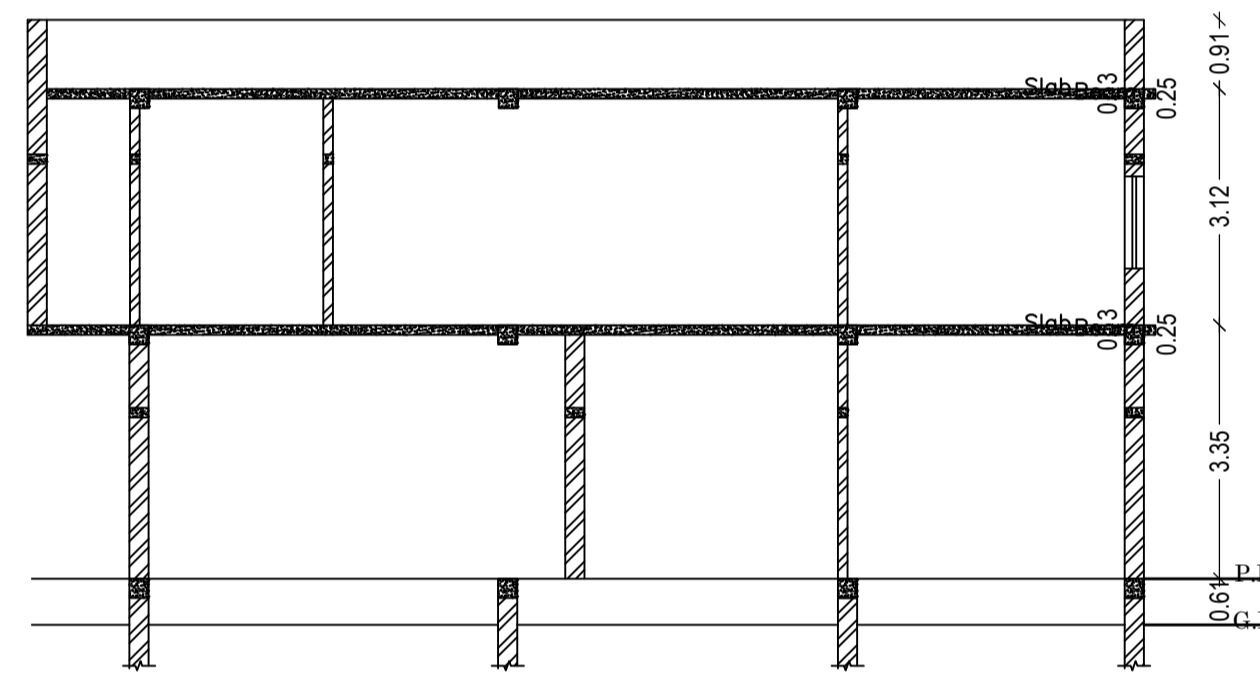

SECTION ON (SCALE 1:100)

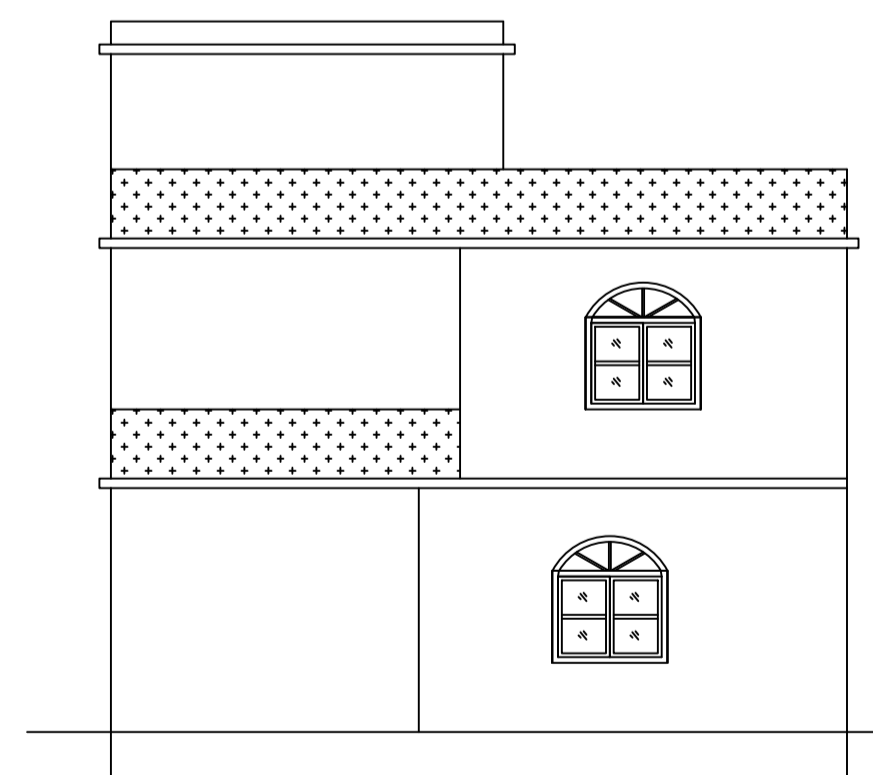

FRONT ELEVATION (SCALE 1:100)

SCHEDULE OF DOOR:

BUILDING NAME	NAME	LENGTH	HEIGHT	NOS
A (RESIDENCE)	D2	0.77	2.10	02
A (RESIDENCE)	D1	0.91	2.10	02
A (RESIDENCE)	D	1.07	2.10	04
A (RESIDENCE)	D	1.08	2.10	01
A (RESIDENCE)	D	1.10	2.10	02
A (RESIDENCE)	D	1.22	2.10	02

SCHEDULE OF WINDOW/VENTILATION:

BUILDING NAME	NAME	LENGTH	HEIGHT	NOS
A (RESIDENCE)	V	0.61	1.20	02
A (RESIDENCE)	W	1.22	1.20	02
A (RESIDENCE)	W	1.52	1.20	11

UnitBUA Table for Building :A (RESIDENCE)

FLOOR	Name	UnitBUA Type	UnitBUA Area	Carpet Area	No. of Rooms	No. of Tenement
GROUND FLOOR PLAN	SPLIT A	FLAT	178.93	178.64	6	1
FIRST FLOOR PLAN	SPLIT A	FLAT	0.00	0.00	8	0
Total:	-	-	178.93	178.64	14	1

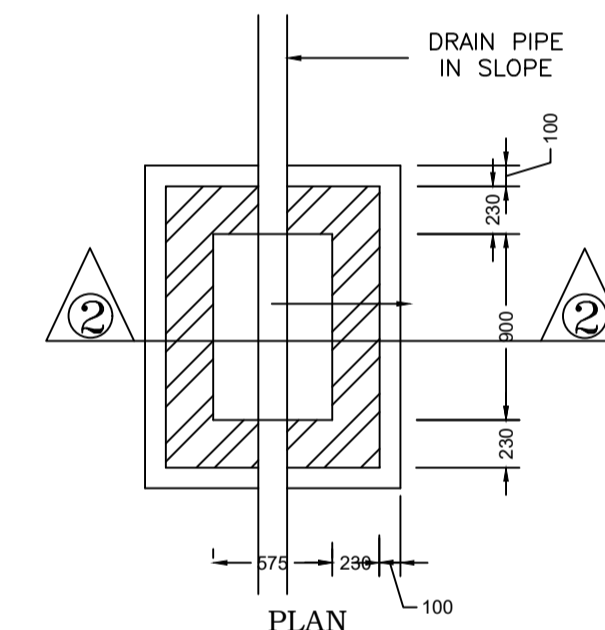
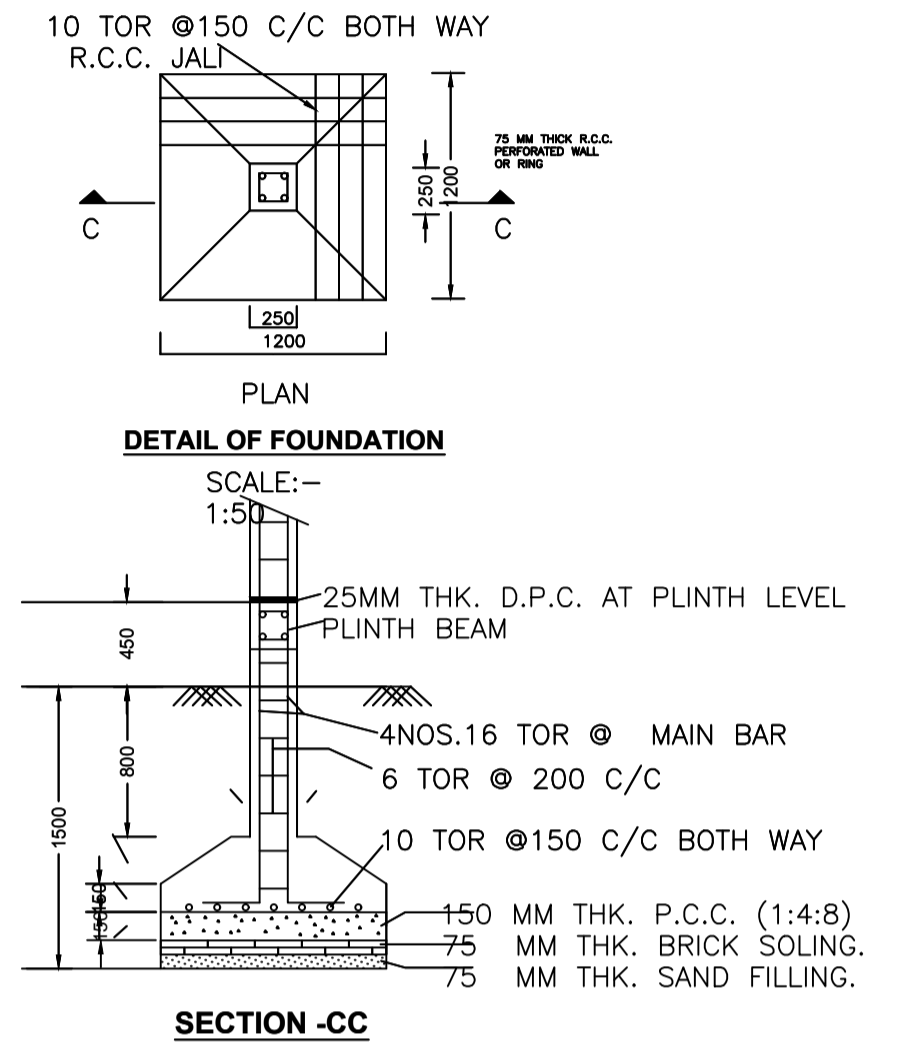
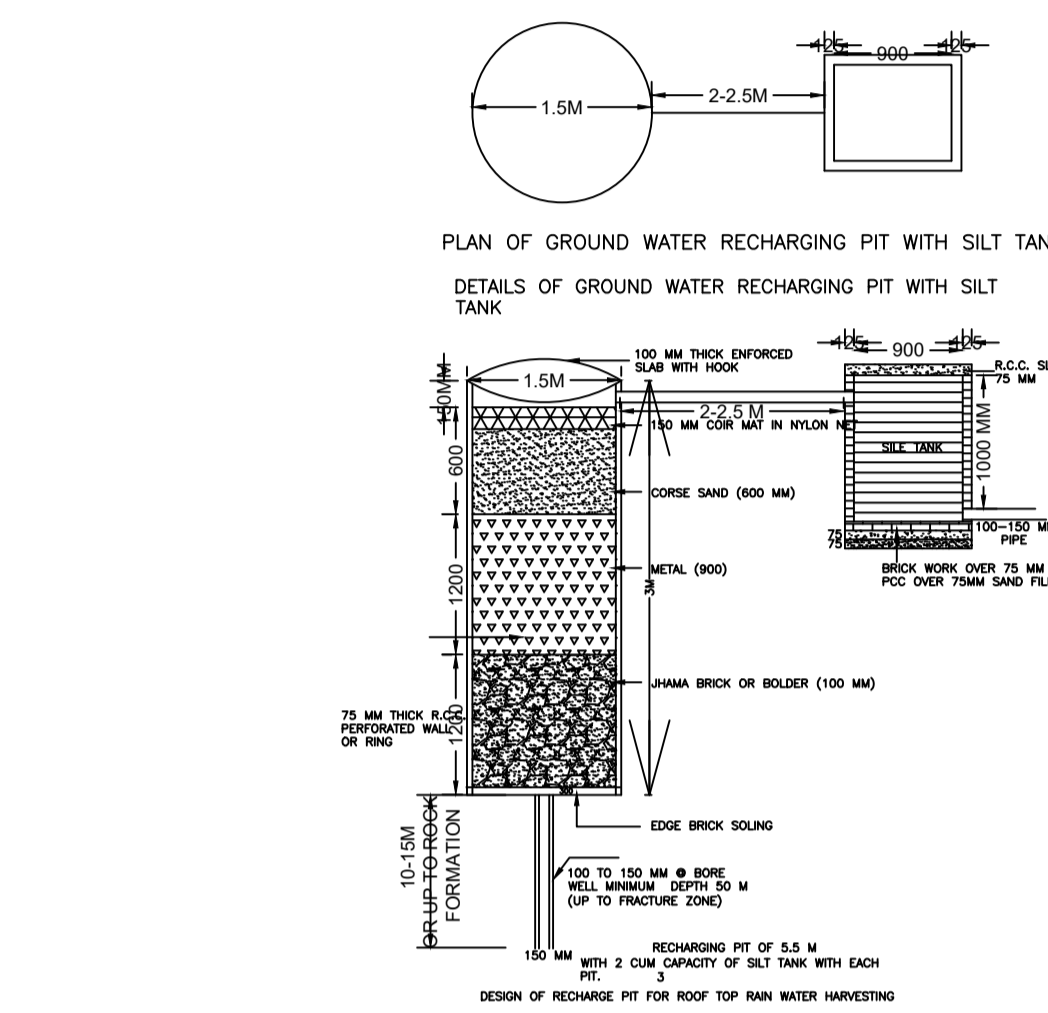

I.C. DETAILS

R.C.C. COVER

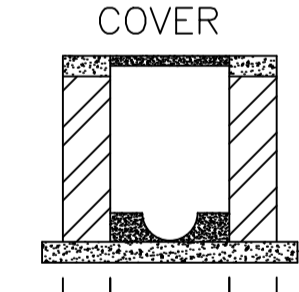

SECTION AT 2-2

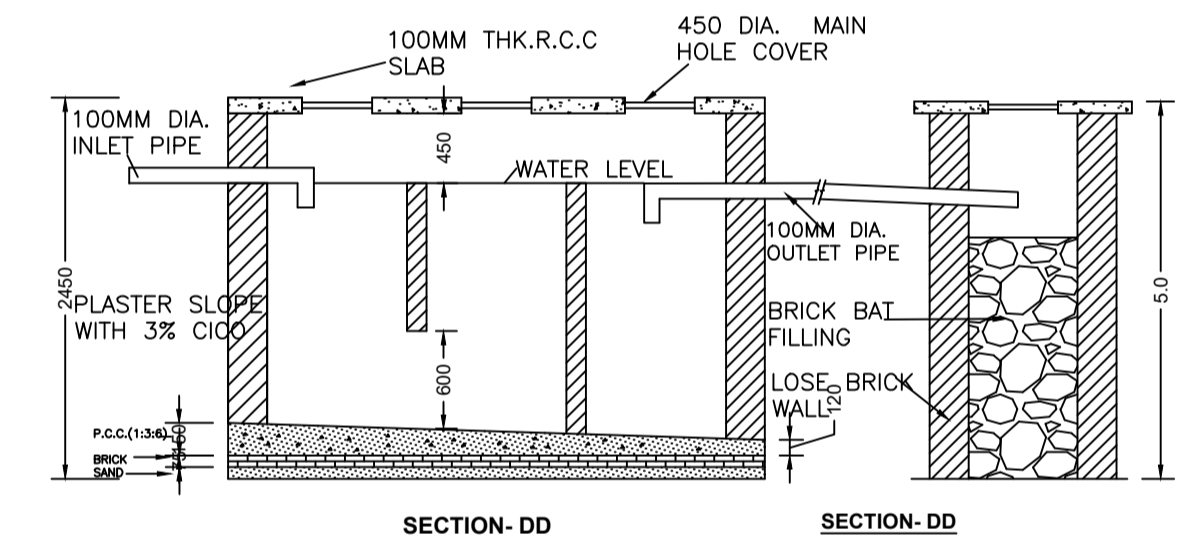

SECTION-DD

SECTION-DD

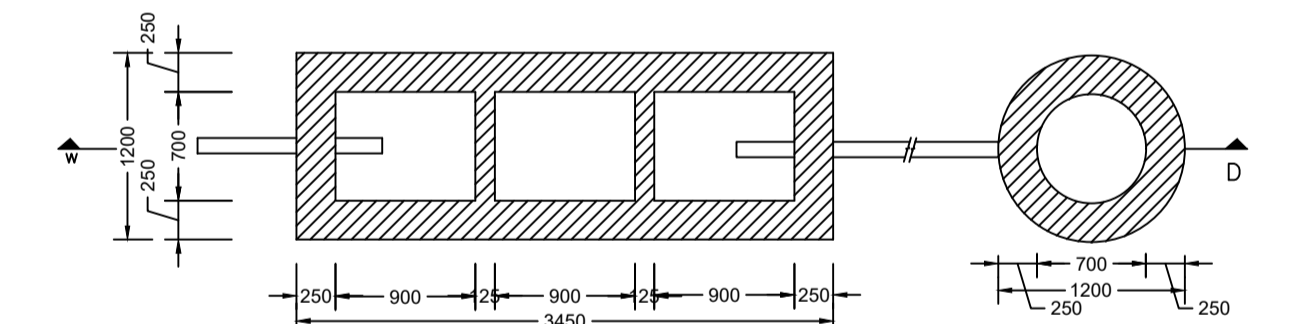

DETAIL OF SEPTIC TANK & SOAKPIT.

PLAN (SCALE - 1:50)

Building :A (RESIDENCE)

Floor Name	Total Built Up Area (Sq.mt.)	Proposed FAR Area (Sq.mt.)	Total FAR Area (Sq.mt.)	Total Consumed Additional FAR Area (Sq.mt.)	Tnmt (No.)
Ground Floor	98.33	98.33	98.33	98.33	01
First Floor	109.54	109.54	109.54	109.54	00
Terrace Floor	0.00	0.00	0.00	0.00	00
Total:	207.87	207.87	207.87	207.87	01
Total Number of Same Buildings	1				
Total:	207.87	207.87	207.87	207.87	01

LTP NAME AND SIGNATURE	STRUCTURAL ENG'S NAME AND SIGNATURE	BUILDER NAME AND SIGNATURE	DIGITAL SIGNATURE
MAHENDRA MEHTA SINPC/DFTMN/002/2022			

Proposal Basic Information	
Proposal File No.	SINPC/BP/0370/W03/2022
Owner Name	MANJU MINZ
Khata No	06
Plot No	1135
Village Name	Saldega
Use	Residential
SubUse	Bungalow/ Dwelling / Non Apartment

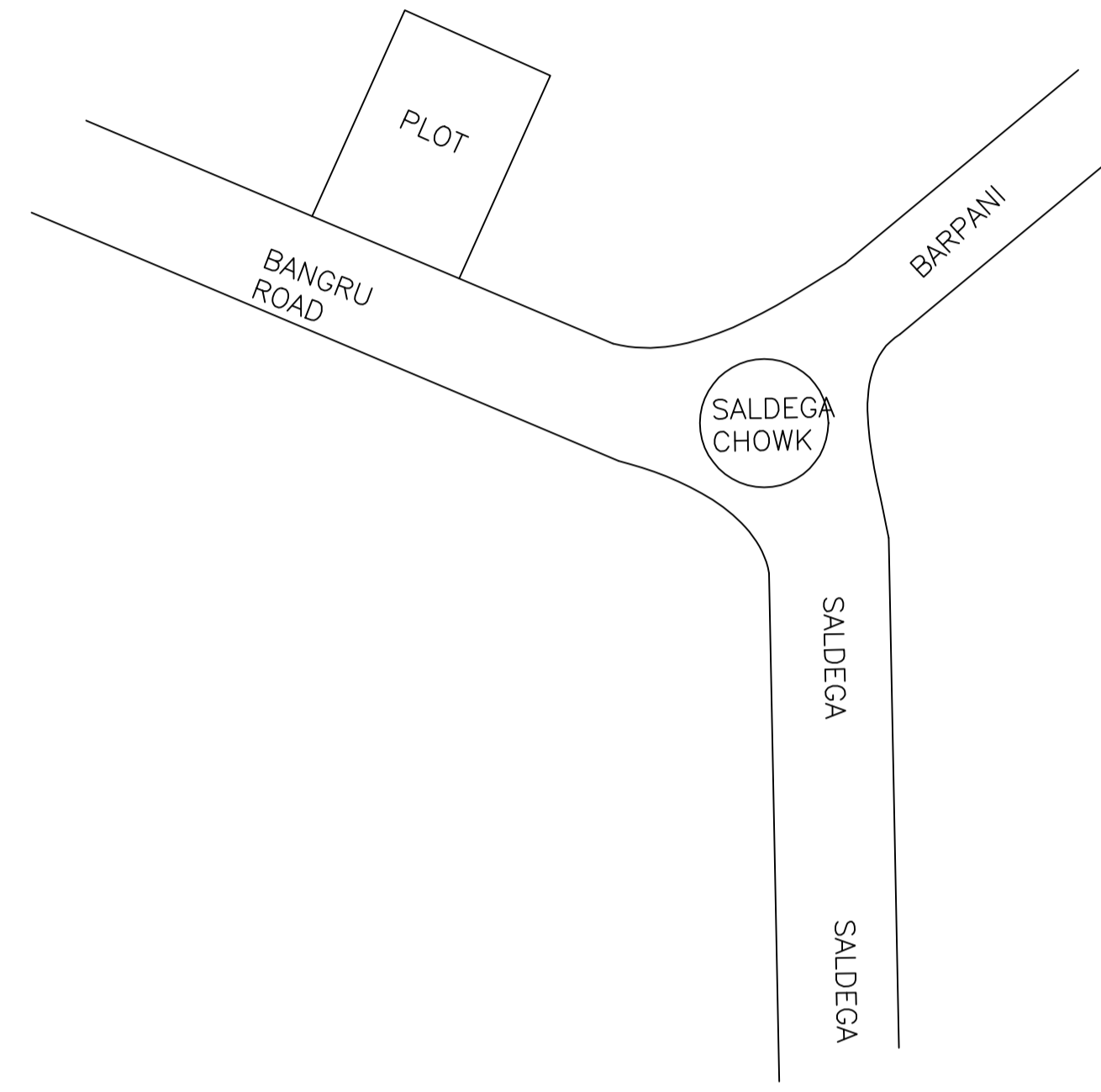

LOCATION PLAN  
NOT IN SCALE

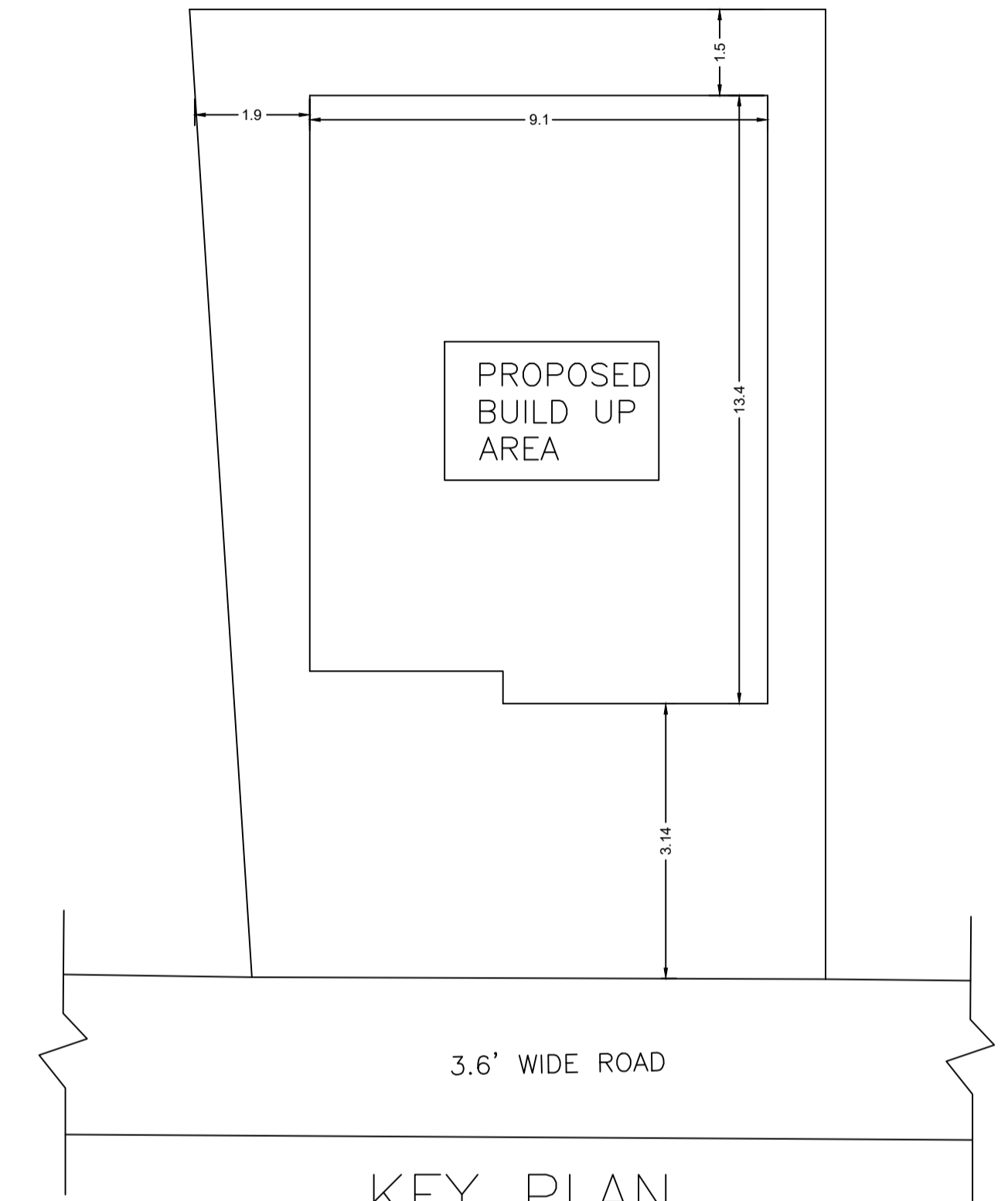

KEY PLAN  
SCALE 1:200

LTP NAME AND SIGNATURE	STRUCTURAL ENG'S NAME AND SIGNATURE	BUILDER NAME AND SIGNATURE	DIGITAL SIGNATURE
MAHENDRA MEHTA SINPC/DFTMN/0002/2022			