

Proposal Basic Information	
Proposal File No.	SINPC/BP/0293/W06/2022
Owner Name	DAUD XESS
Khata No	113
Plot No	2385
Village Name	Khijri
Use	Commercial
SubUse	Shop

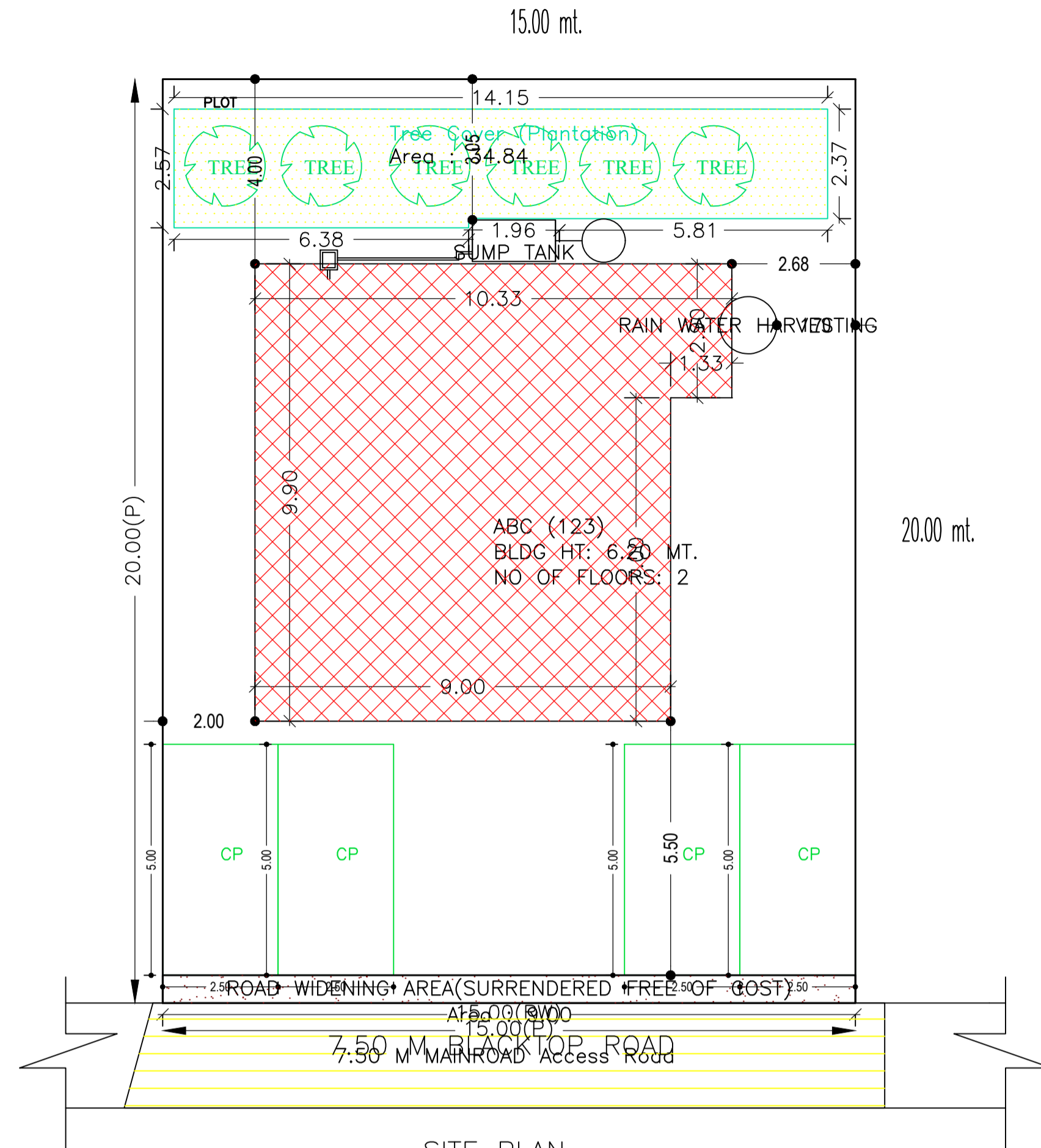

SITE PLAN

FAR & Tenement Details (Table 4c-1)

Building	No. of Same Bldg	Total Built Up Area (Sq.mt.)	Deductions (Area in Sq.mt.)		Proposed FAR Area (Sq.mt.)	Add Area In FAR (Sq.mt.)	Total FAR Area (Sq.mt.)	Total Consumed Additional FAR Area (Sq.mt.)	Trmt (No.)
			Parking	Commercial					
ABC (123)	1	185.88	82.86	92.94	92.94	10.08	103.02	103.02	01
Grand Total :	1	185.88	82.86	92.94	92.94	10.08	103.02	103.02	01

Building USE/SUBUSE Details

Building Name	Building Use	Building SubUse	Building Structure
ABC (123)	Commercial	Shop	Non-Highrise

Required Parking (Table 7a)

Building Name	Type	SubUse	Area (Sq.mt.)	Units		Car		TwoWheeler	
				Reqd.	Prop.	Reqd./Unit	Prop.	Reqd./Unit	Prop.
ABC (123)	Commercial	Shop	> 0	50	82.86	1	2	-	-
			> 0	50	82.86	-	-	1	4
Total :			-	-	-	-	2	4	4

Parking Check (Table 7b)

Vehicle Type	Reqd.		Prop.	
	No.	Area	No.	Area
Car	-	-	4	50.00
Total Car	2	25.00	4	50.00
TwoWheeler	-	-	6	12.00
Total TwoWheeler	4	8.00	6	12.00
Other Parking	-	-	-	70.86
Total		33.00		144.86

AREA STATEMENT SIMDEGA NAGAR PANCHAYAT		VERSION NO.: 1.0.62
PROJECT DETAIL:		VERSION DATE: 16/10/2020
Region: JHARKHAND URBAN LOCAL BODIES	Plot Use: Commercial	
District: SIMDEGA PANCHAYAT	Plot SubUse: Shop	
Authority: SIMDEGA NAGAR PANCHAYAT	PlotNearby/ReligiousStructure: NA	
Inward No: SINPC/BP/0293/W06/2022	Plot/SubPlot No: 2385	
Application Type: General Proposal	North: -	
Project Type: Building Permission	South: -	
Nature of Development: New	East: -	
Location of Development Area: Old Area	West: -	
AREA DETAILS:		SQ.MT.
AREA OF PLOT (Minimum)	(A)	300.00
Deduction for NetPlot Area		
Surrender Free of Cost		9.00
Total		9.00
NET AREA OF PLOT(Gross Plot Area - Deduction from Gross Plot area)	(A-Deductions)	291.00
Deduction for Balance Plot Area(from Gross Plot Area)		
Surrender Free of Cost		9.00
Common Plot		34.84
Total		43.84
BALANCE AREA OF PLOT(Net Plot Area - Recreational/Amenity space)	(A-Deductions)	256.16
PLOT AREA FOR COVERAGE(Net Plot Area)	(A-Deductions)	291.00
Plot Area for FAR (Net Plot Area + RoadWidening Area)	(A-Deductions)	300.00
COVERAGE CHECK		
Permissible Coverage area (50.00 %)		145.50
Proposed Coverage Area (31.94 %)		92.94
Total Prop. Coverage Area (31.94 %)		92.94
Balance coverage area (18.06 %)		52.56
FAR CHECK		
Perm. FAR Area (2.00)		600.00
Total Perm. FAR area		600.00
Commercial FAR		92.94
Proposed FAR Area		103.02
Total Proposed FAR Area		103.02
Consumed FAR (Factor)		0.34
Balance FAR Area		496.98
BUILT UP AREA CHECK		
Total Proposed BuiltUp Area		185.88
ARCHITECT (Regd)		MD RAGIB SAYEED
ENGINEER (Regd)		
SUPERVISOR (Regd)		
OWNER (Regd)		DAUD XESS
DEVELOPMENT AUTHORITY		LOCAL BODY

COLOR INDEX	
PLOT BOUNDARY	Black
ABUTTING ROAD	Green
PROPOSED CONSTRUCTION	Red
COMMON PLOT	Yellow
ROAD WIDENING AREA	Blue
EXISTING (To be retained)	Light Blue
EXISTING (To be demolished)	Dark Blue

Buildingwise Floor FAR Details

Floor Name	Building Name		Total	
	Proposed Built Up Area (Sq.mt.)	Proposed FAR Area (Sq.mt.)	Total Proposed Built Up Area (Sq.mt.)	Total FAR Area (Sq.mt.)
Ground Floor	92.94	10.08	92.94	10.08
First Floor	92.94	92.94	92.94	92.94
Terrace Floor	0.00	0.00	0.00	0.00
Total :	185.88	103.02	185.88	103.02

LTP NAME AND SIGNATURE	STRUCTURAL ENG'S NAME AND SIGNATURE	BUILDER NAME AND SIGNATURE	DIGITAL SIGNATURE
MD RAGIB SAYEED SINPC/ENG/0001/2017			

Proposal Basic Information	
Proposal File No.	SINPC/BP/0293/W06/2022
Owner Name	DAUD XESS
Khata No	113
Plot No	2385
Village Name	Khijri
Use	Commercial
SubUse	Shop

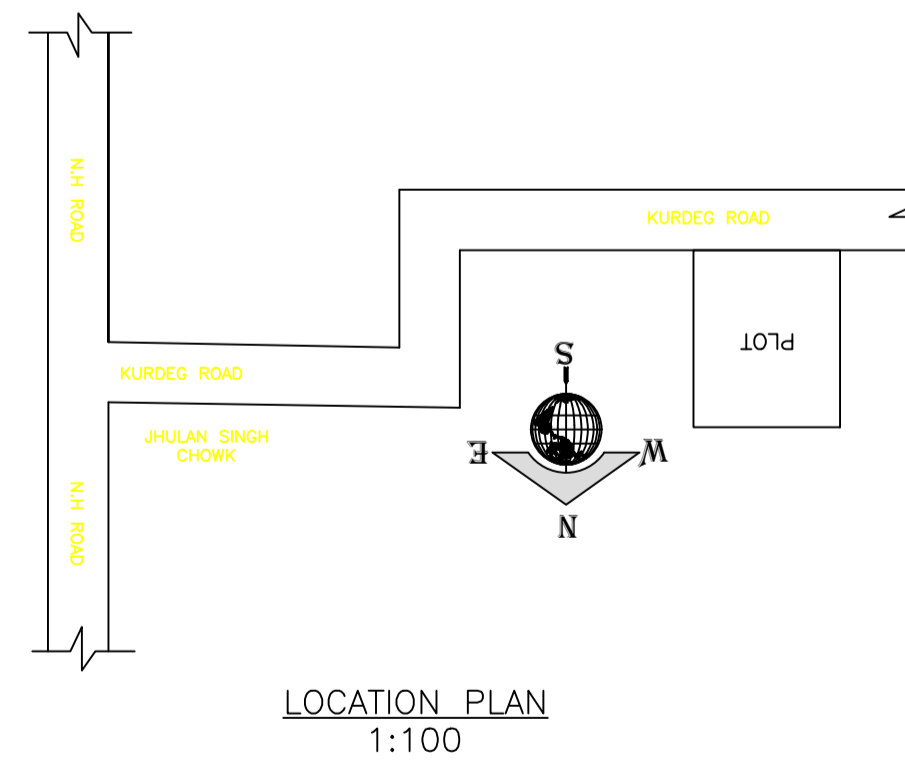
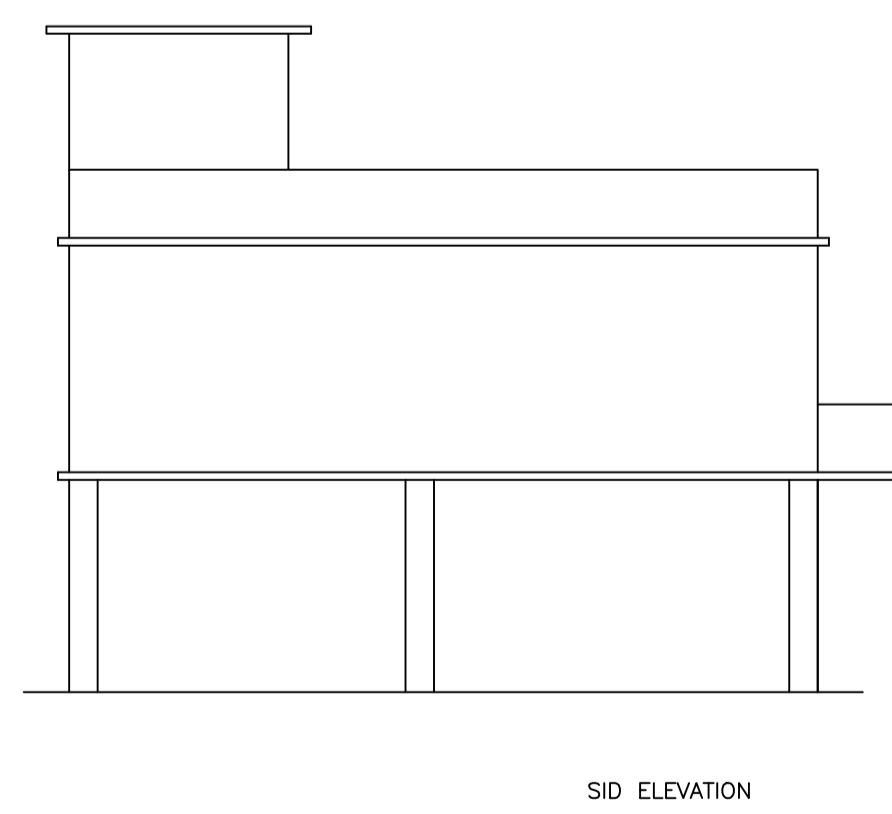
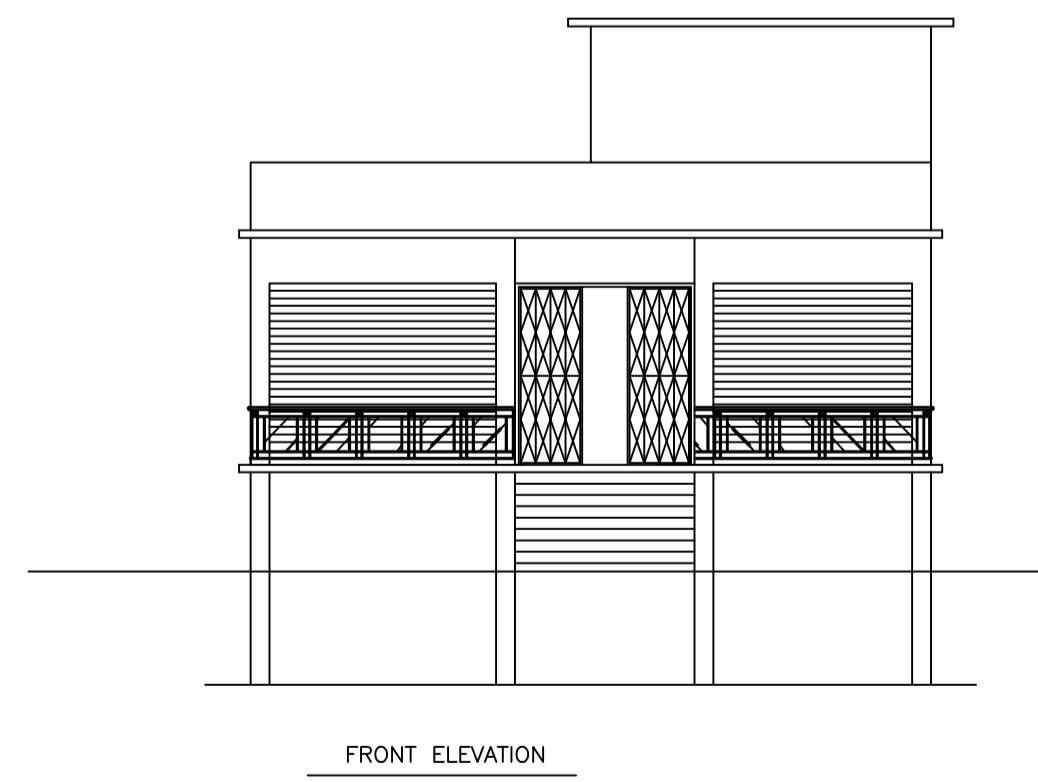
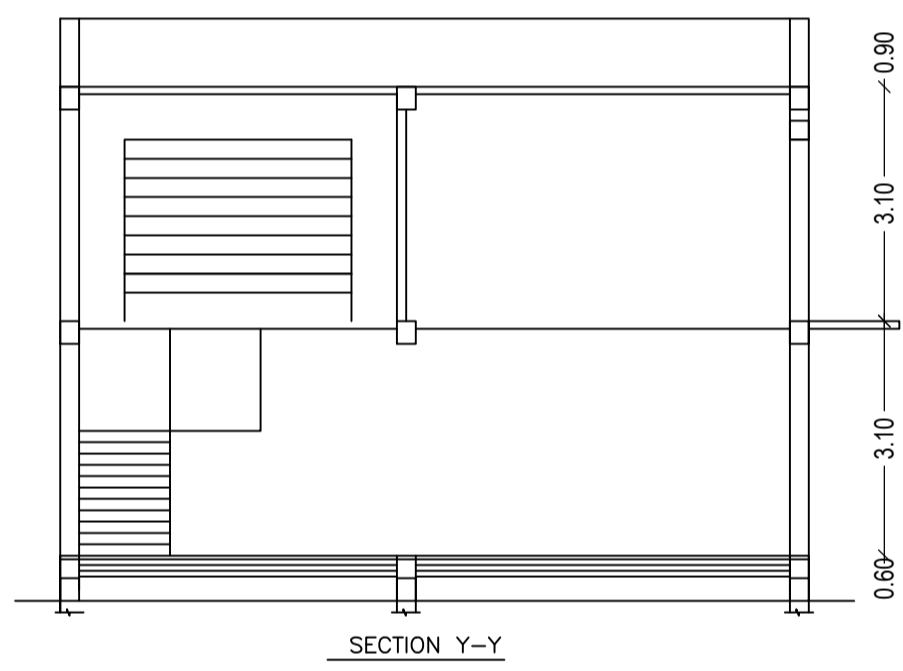
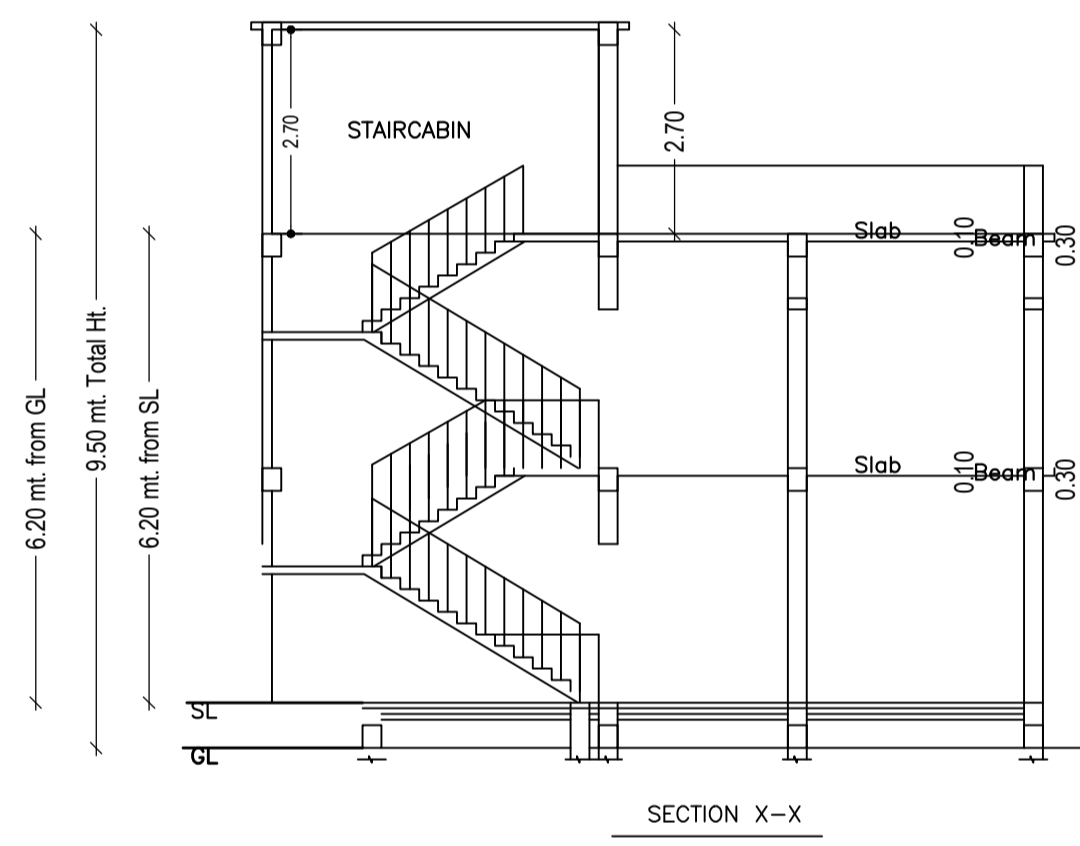
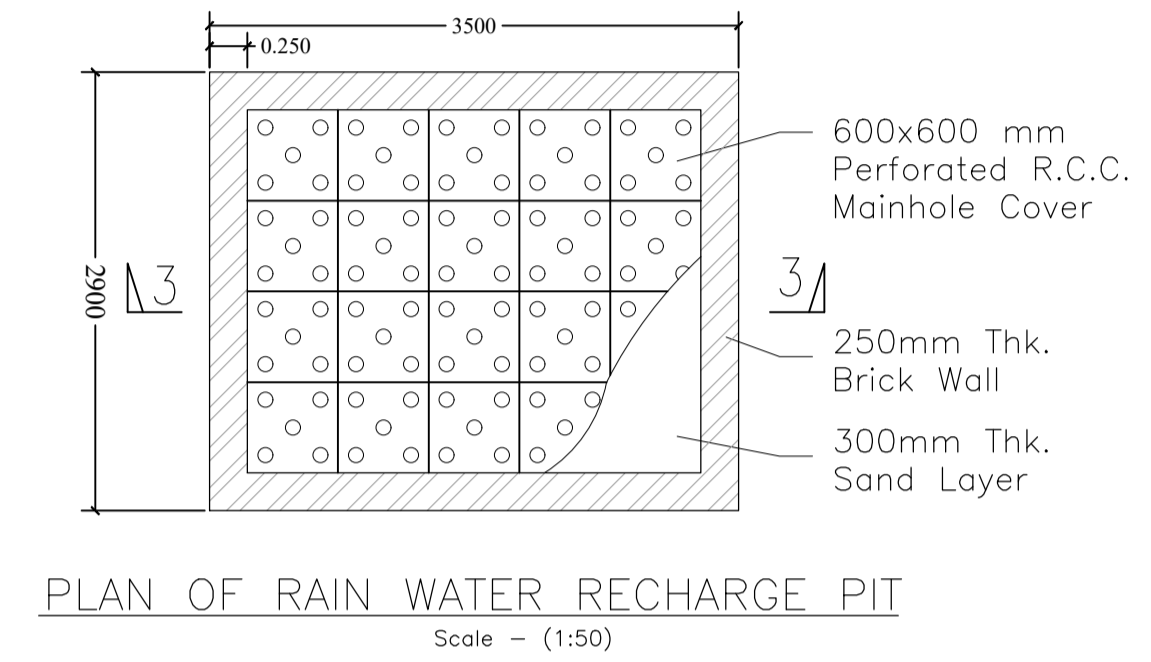
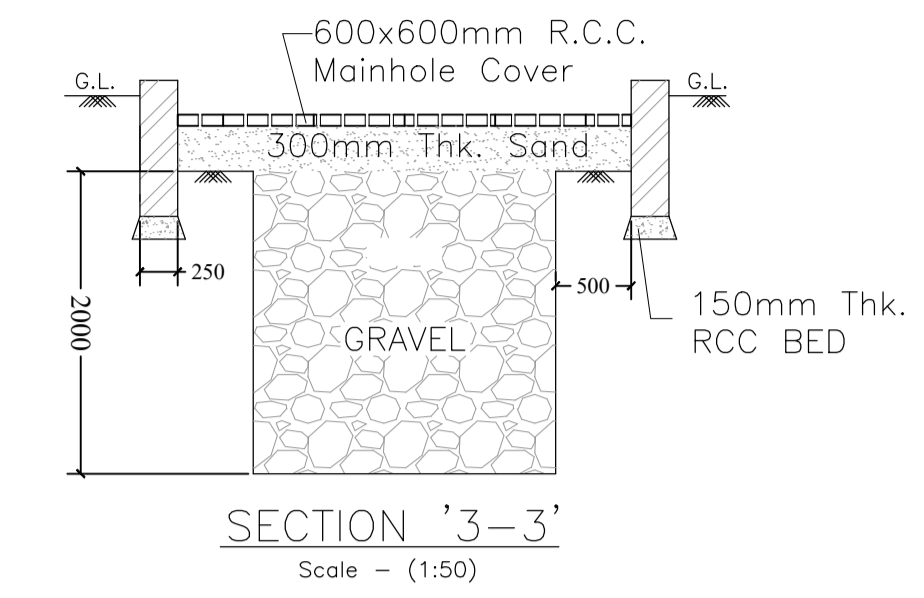
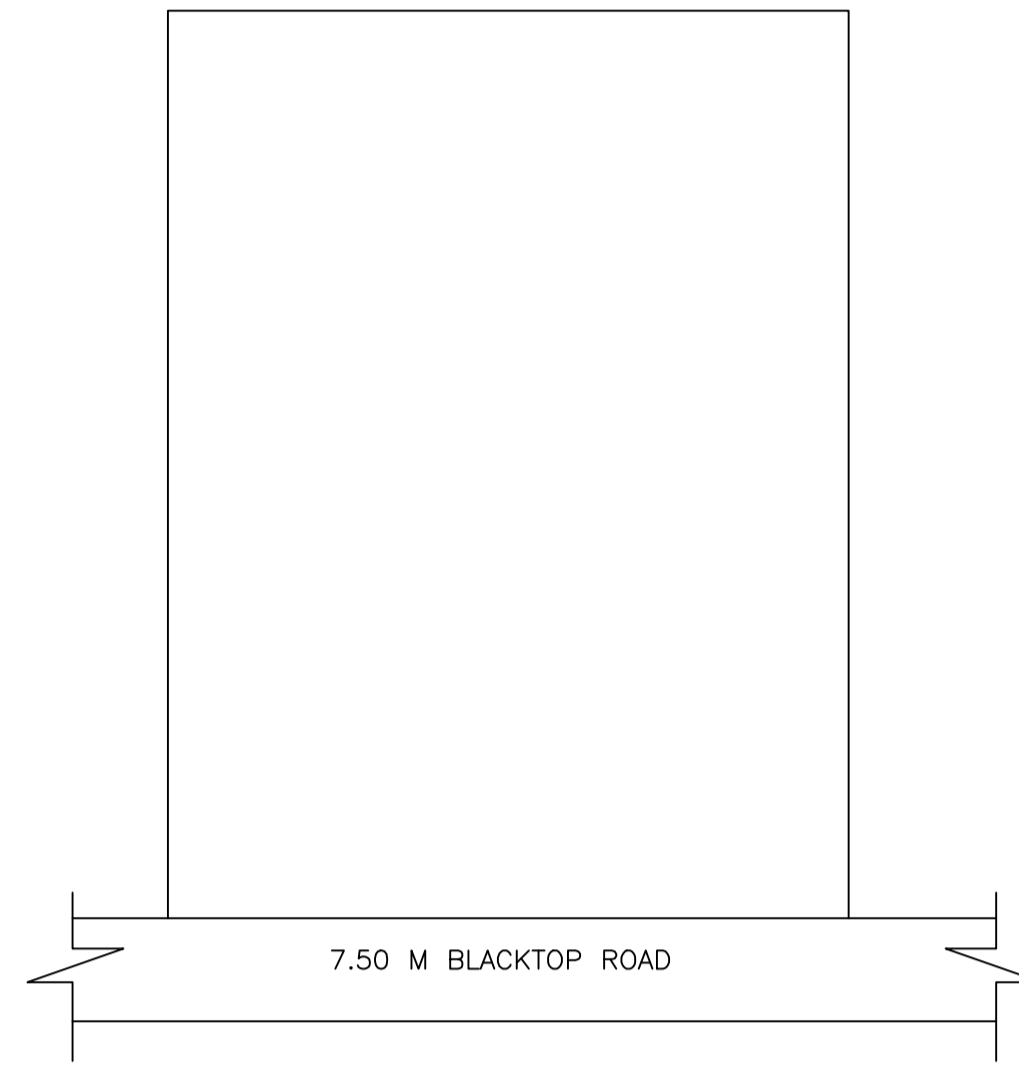
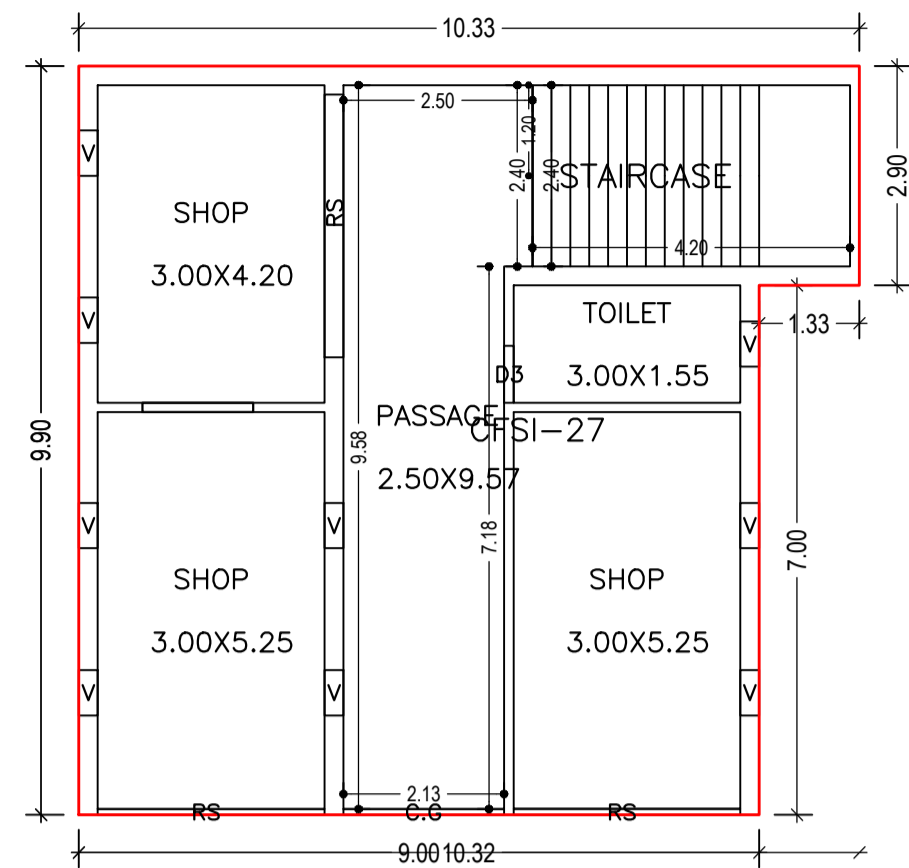
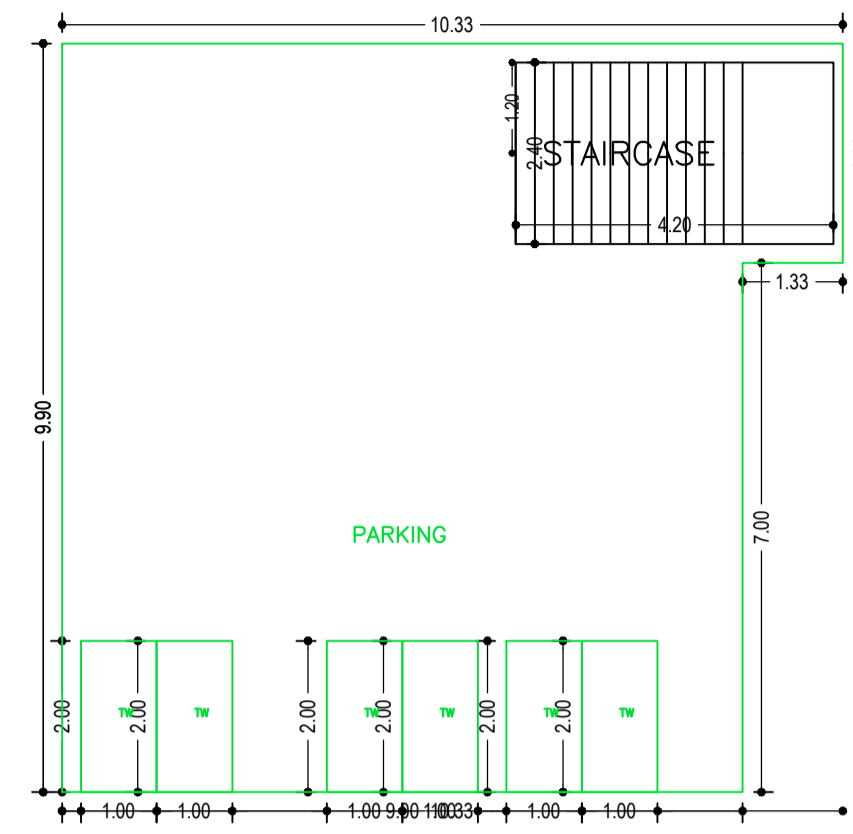

LTP NAME AND SIGNATURE	STRUCTURAL ENG'S NAME AND SIGNATURE	BUILDER NAME AND SIGNATURE	DIGITAL SIGNATURE
MD RAGIB SAYEED SINPC/ENG/0001/2017			