

SITE PLAN

FAR & Tenement Details (Table 4c-1)

Building	No. of Same Bldg	Total Built Up Area (Sq.mt.)	Proposed FAR Area (Sq.mt.) Resi.	Total FAR Area (Sq.mt.)	Total Consumed Additional FAR Area (Sq.mt.)	Tnmt (No.)
ABC (123)	1	212.42	212.42	212.42	212.42	01
Grand Total :	1	212.42	212.42	212.42	212.42	01

Proposal Basic Information	
Proposal File No.	SINPC/BP/0289/W07/2022
Owner Name	RAJSRI DEVI
Khata No	1
Plot No	701
Village Name	Saldega
Use	Residential
SubUse	Bungalow/ Dwelling / Non Apartment

AREA STATEMENT SIMDEGA NAGAR PANCHAYAT		VERSION NO. : 1.0.62
PROJECT DETAIL		VERSION DATE: 16/10/2020
Region: JHARKHAND URBAN LOCAL BODIES	Plot Use: Residential	
District: SIMDEGA	Plot SubUse: Bungalow/ Dwelling / Non Apartment	
Authority: SIMDEGA NAGAR PANCHAYAT	PlotNearbyReligiousStructure: NA	
Inward No: SINPC/BP/0289/W07/2022	Plot/SubPlot No: 701	
Application Type: General Proposal	North: -	
Project Type: Building Permission	South: -	
Nature of Development: New	East: -	
Location of Development Area: Old Area	West: -	
AREA DETAILS:		
AREA OF PLOT (Minimum)	(A)	SQ.MT. 163.51
Deduction for NetPlot Area		
Surrender Free of Cost		4.17
Total		4.17
NET AREA OF PLOT(Gross Plot Area - Deduction from Gross Plot area)		
(A-Deductions)		159.34
Deduction for Balance Plot Area(from Gross Plot Area)		
Surrender Free of Cost		4.17
Common Plot		13.42
Total		17.59
BALANCE AREA OF PLOT(Net Plot Area - Recreational/Amenity space)		
(A-Deductions)		145.92
PLOT AREA FOR COVERAGE(Net Plot Area)		
(A-Deductions)		159.34
Plot Area for FAR (Net Plot Area + RoadWidening Area)		
(A-Deductions)		163.51
COVERAGE CHECK		
Permissible Coverage area (70.00 %)		111.54
Proposed Coverage Area (68.37 %)		108.94
Total Prop. Coverage Area (68.37 %)		108.94
Balance coverage area (1.63 %)		2.60
FAR CHECK		
Perm. FAR Area (1.50)		245.26
Total Perm. FAR area		245.26
Residential FAR		212.42
Proposed FAR Area		212.42
Total Proposed FAR Area		212.42
Consumed FAR (Factor)		1.30
Balance FAR Area		32.84
BUILT UP AREA CHECK		
Total Proposed BuiltUp Area		212.42
ARCHITECT (Regd)		MD RAGIB SAYEED
ENGINEER (Regd)		
SUPERVISOR (Regd)		
OWNER (Regd)		RAJSRI DEVI
DEVELOPMENT AUTHORITY		LOCAL BODY

COLOR INDEX	
PLOT BOUNDARY	Black
ABUTTING ROAD	Green
PROPOSED CONSTRUCTION	Red
COMMON PLOT	Yellow
ROAD WIDENING AREA	Blue
EXISTING (To be retained)	Blue
EXISTING (To be demolished)	Yellow

Buildingwise Floor FAR Details

Floor Name	Building Name		Total	
	Proposed Built Up Area (Sq.mt.)	Proposed FAR Area (Sq.mt.)	Total Proposed Built Up Area (Sq.mt.)	Total FAR Area (Sq.mt.)
Ground Floor	108.94	108.94	108.94	108.94
First Floor	103.48	103.48	103.48	103.48
Terrace Floor	0.00	0.00	0.00	0.00
Total	212.42	212.42	212.42	212.42

Building USE/SUBUSE Details

Building Name	Building Use	Building SubUse	Building Structure
ABC (123)	Residential	Bungalow/ Dwelling / Non Apartment	Non-Highrise

LTP NAME AND SIGNATURE	STRUCTURAL ENG'S NAME AND SIGNATURE	BUILDER NAME AND SIGNATURE	DIGITAL SIGNATURE
MD RAGIB SAYEED SINPC/ENG/0001/2017			



Proposal Basic Information	
Proposal File No.	SINPC/BP/0289/W07/2022
Owner Name	RAJSRI DEVI
Khata No.	1
Plot No.	701
Village Name	Saldega
Use	Residential
SubUse	Bungalow/ Dwelling / Non Apartment

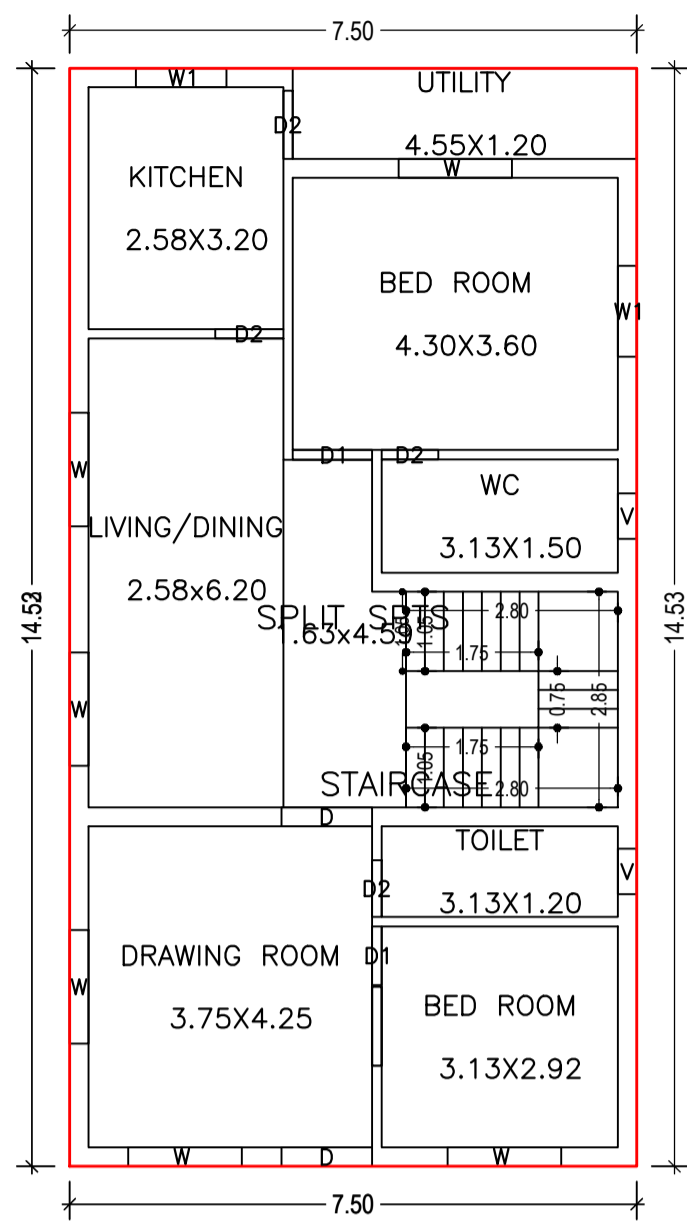

GROUND FLOOR PLAN (Proposed) (SCALE 1:100)

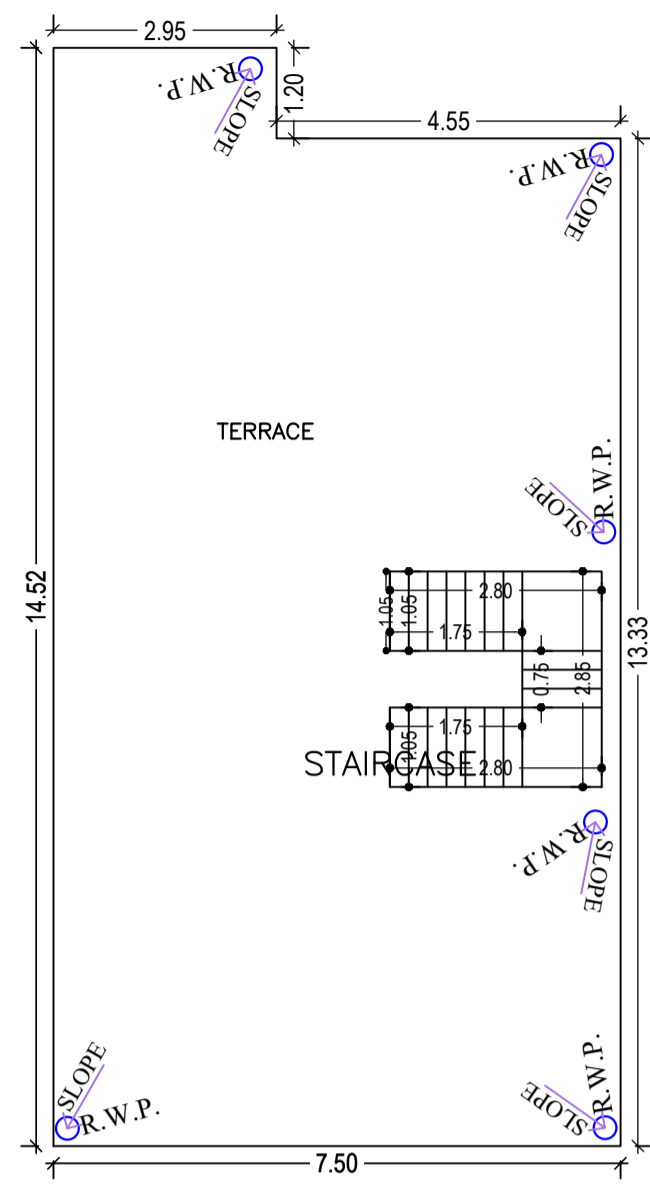

TERRACE FLOOR PLAN (SCALE 1:100)

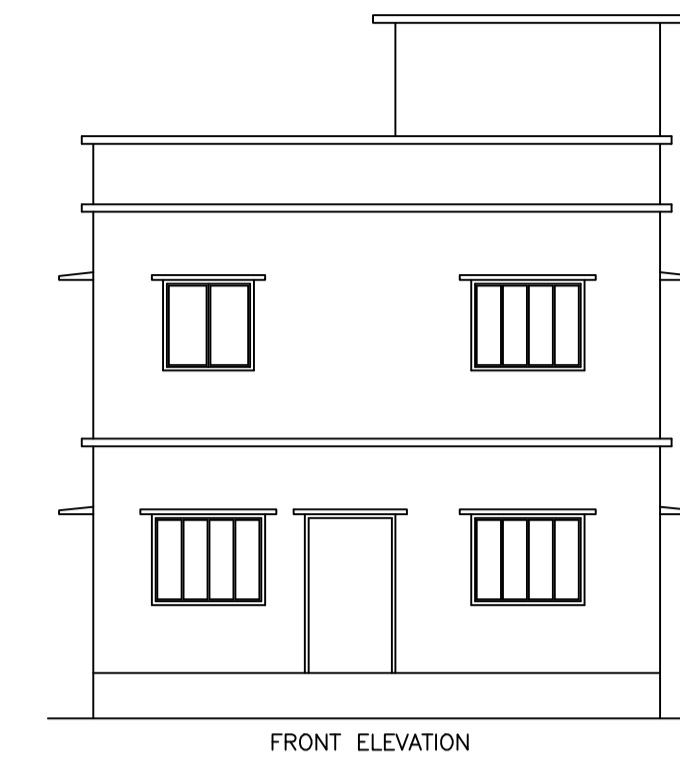

FRONT ELEVATION

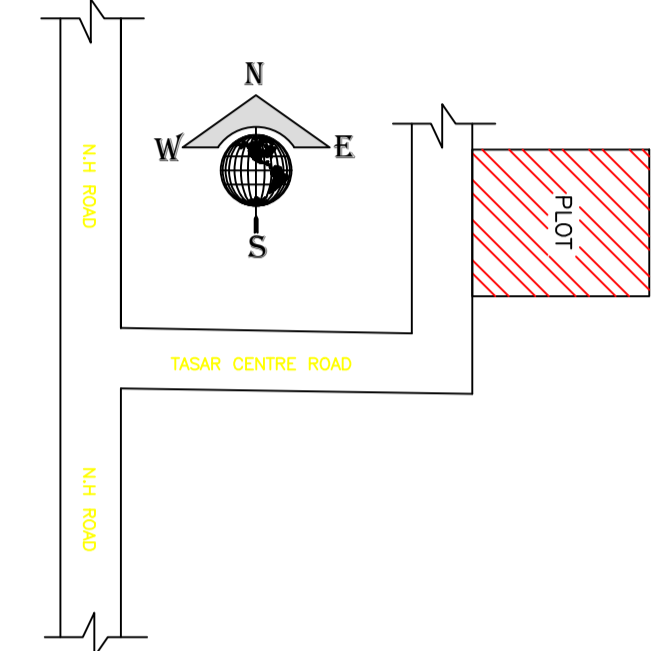

LOCATION PLAN 1:100

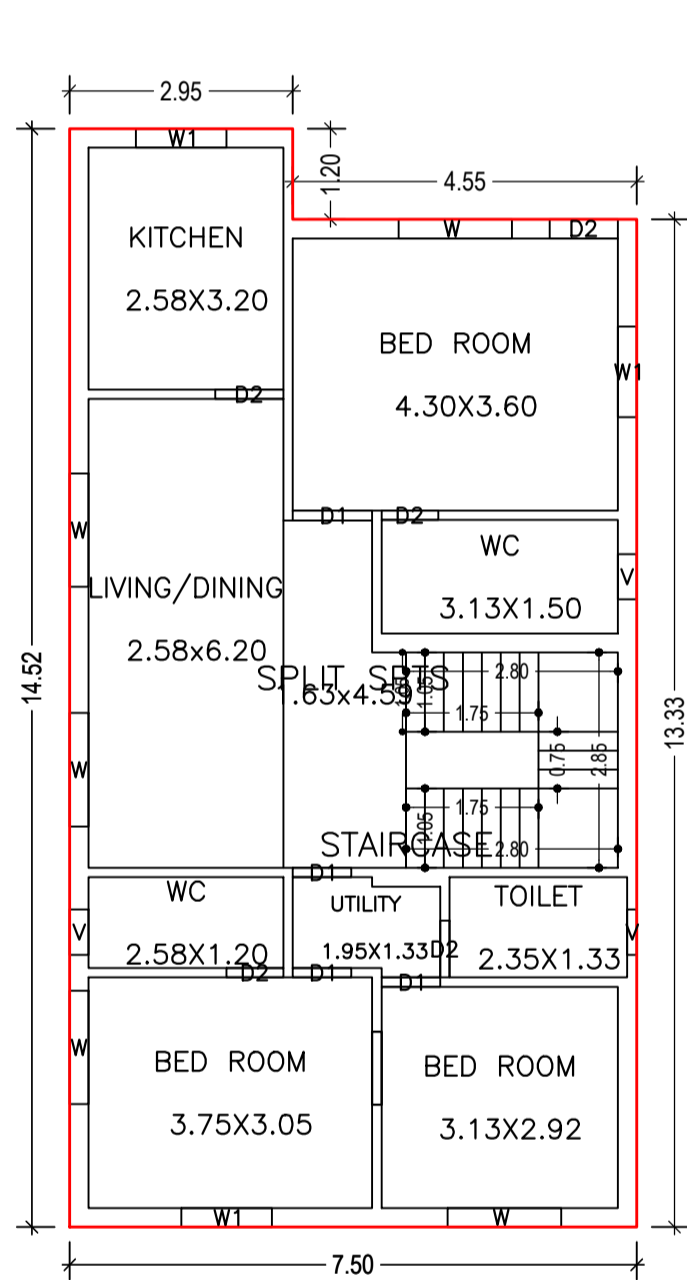

FIRST FLOOR PLAN (Proposed) (SCALE 1:100)

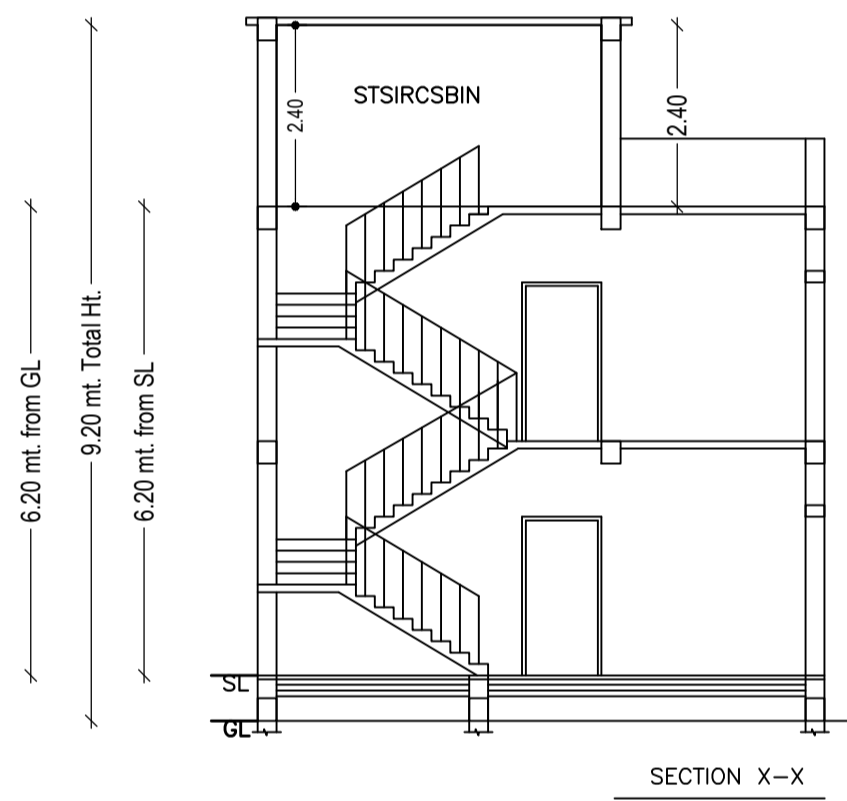

SECTION X-X

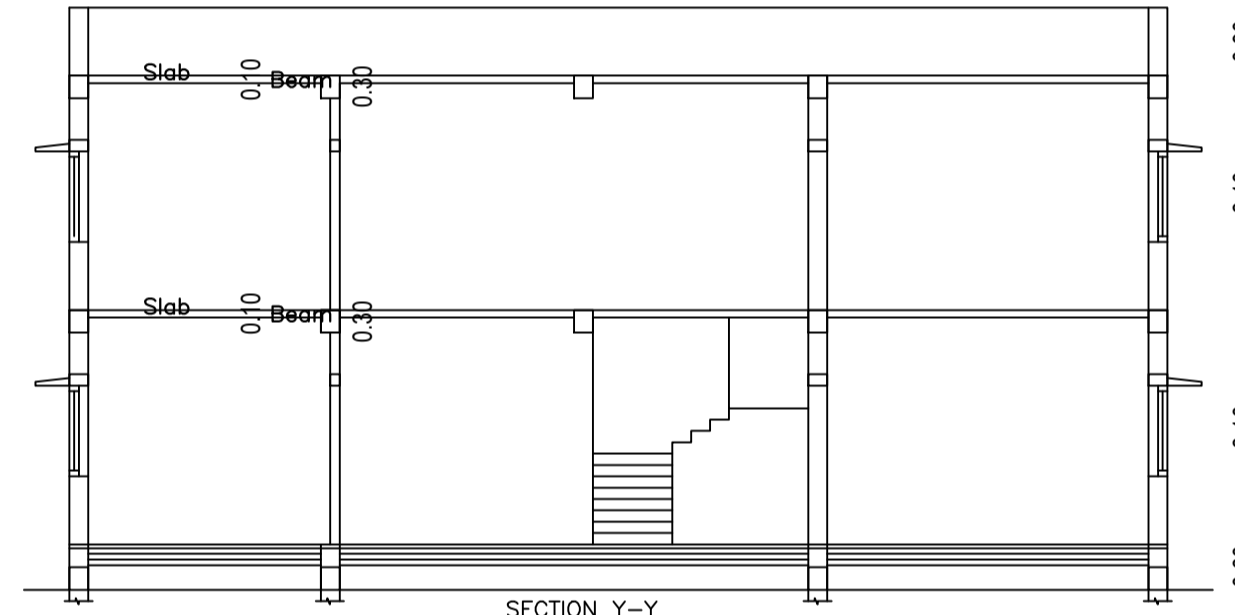

SECTION Y-Y

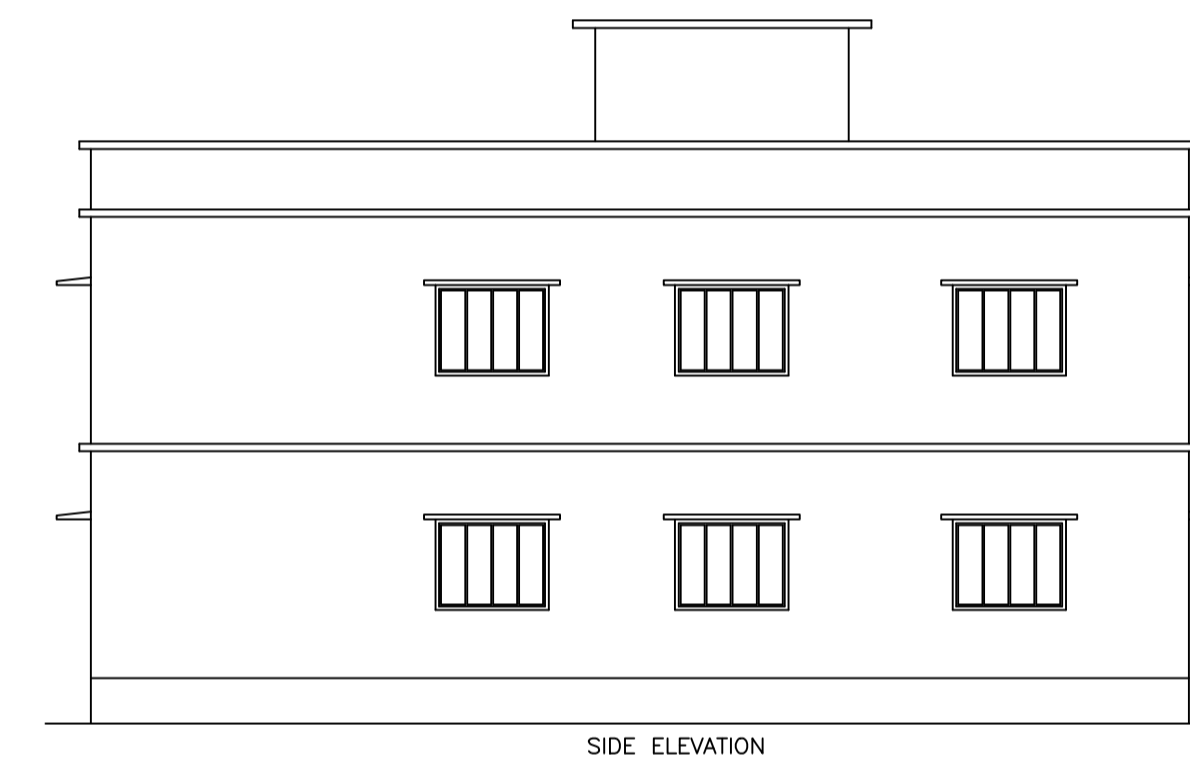

SIDE ELEVATION

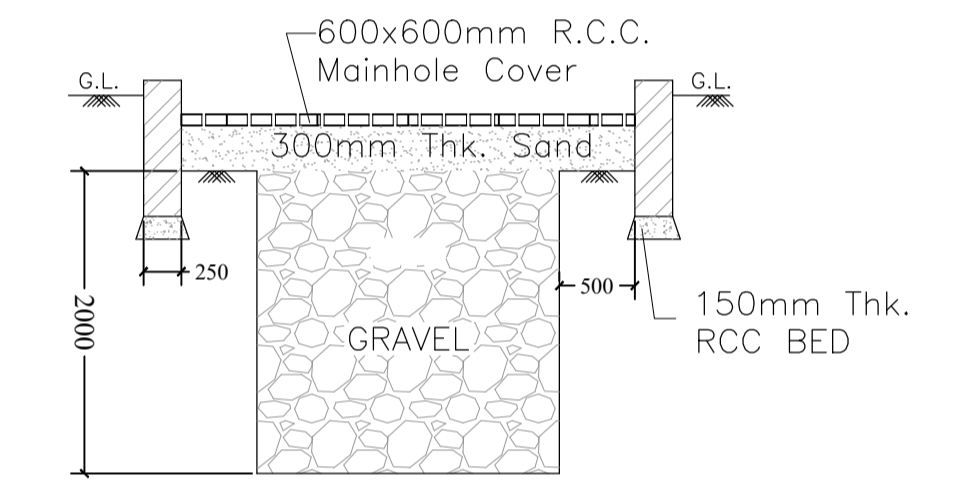

SECTION '3-3' Scale - (1:50)

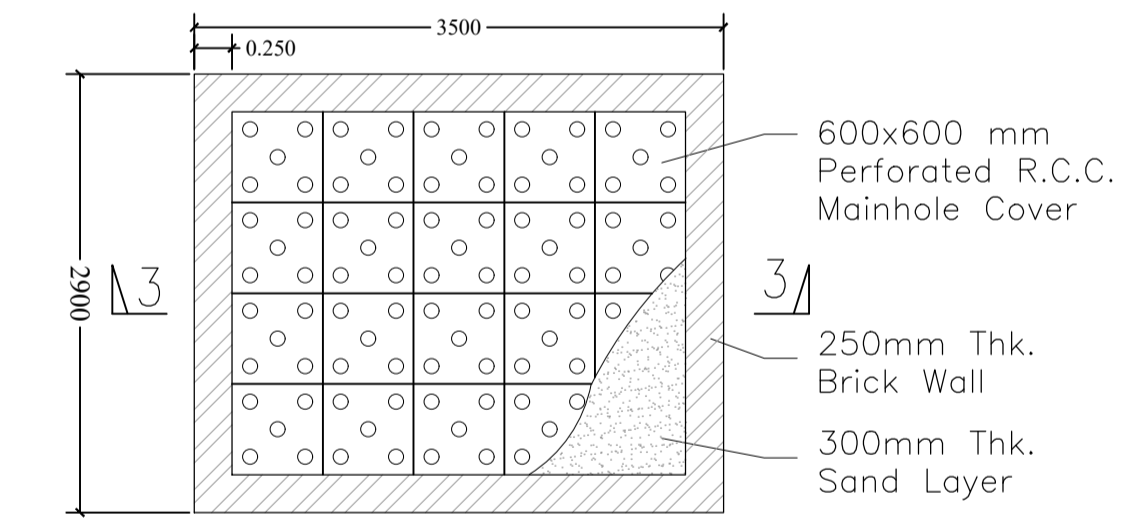

PLAN OF RAIN WATER RECHARGE PIT Scale - (1:50)

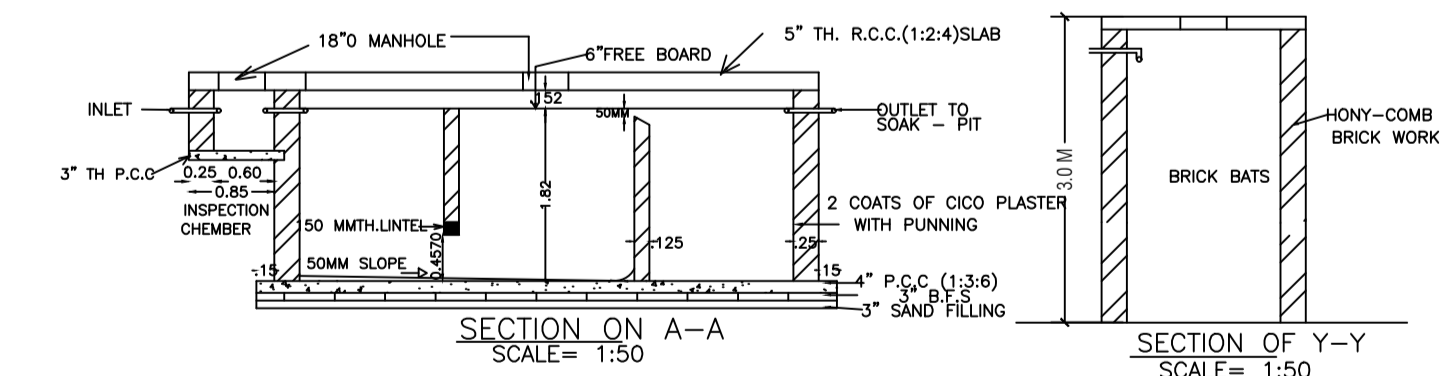

SECTION ON A-A SCALE= 1:50

SECTION OF Y-Y SCALE= 1:50

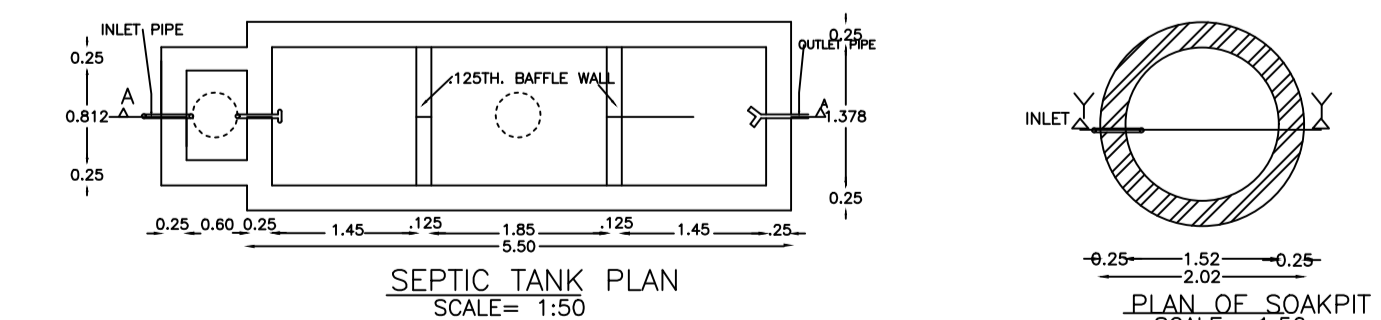

SEPTIC TANK PLAN SCALE= 1:50

PLAN OF SOAKPIT SCALE= 1:50

SCHEDULE OF DOOR:

BUILDING NAME	NAME	LENGTH	HEIGHT	NOS
ABC (123)	D2	0.75	2.10	05
ABC (123)	D1	0.78	2.10	04
ABC (123)	D2	0.90	2.10	04
ABC (123)	D1	1.05	2.10	02
ABC (123)	D	1.20	2.10	02

SCHEDULE OF WINDOW/VENTILATION:

BUILDING NAME	NAME	LENGTH	HEIGHT	NOS
ABC (123)	V	0.60	1.20	05
ABC (123)	W1	1.20	1.20	05
ABC (123)	W	1.50	1.20	11

UnitBUA Table for Building :ABC (123)

FLOOR	Name	UnitBUA Type	UnitBUA Area	Carpet Area	No. of Rooms	No. of Tenement
GROUND FLOOR PLAN	SPLIT SPTS	FLAT	212.42	212.16	8	1
FIRST FLOOR PLAN	SPLIT SPTS	FLAT	0.00	0.00	9	0
Total:	-	-	212.42	212.16	17	1

Building :ABC (123)

Floor Name	Total Built Up Area (Sq.mt.)	Proposed FAR Area (Sq.mt.) Resi.	Total FAR Area (Sq.mt.)	Total Consumed Additional FAR Area (Sq.mt.)	Tnmt (No.)
Ground Floor	108.94	108.94	108.94	108.94	01
First Floor	103.48	103.48	103.48	103.48	00
Terrace Floor	0.00	0.00	0.00	0.00	00
Total:	212.42	212.42	212.42	212.42	01
Total Number of Same Buildings	1				
Total:	212.42	212.42	212.42	212.42	01

LTP NAME AND SIGNATURE	STRUCTURAL ENG'S NAME AND SIGNATURE	BUILDER NAME AND SIGNATURE	DIGITAL SIGNATURE
MD RAGIB SAYEED SINPC/ENG/0001/2017			



DATE	19-07-2022
SHEET NO.	3

Proposal Bas Information	
Proposal File No	SINPC/BP/0289/W07/2022
Owner Name	RAJSRI DEVI
Khata No	1
Plot No	701
Village Name	Saldega
Use	Residential
SubUse	Bungalow/ Dwelling / Non Apartment

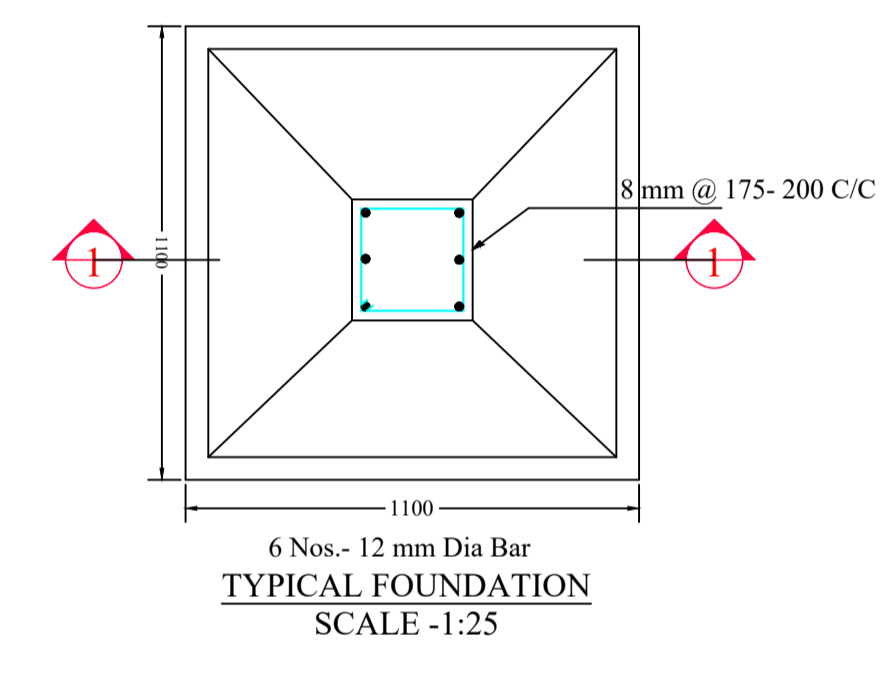
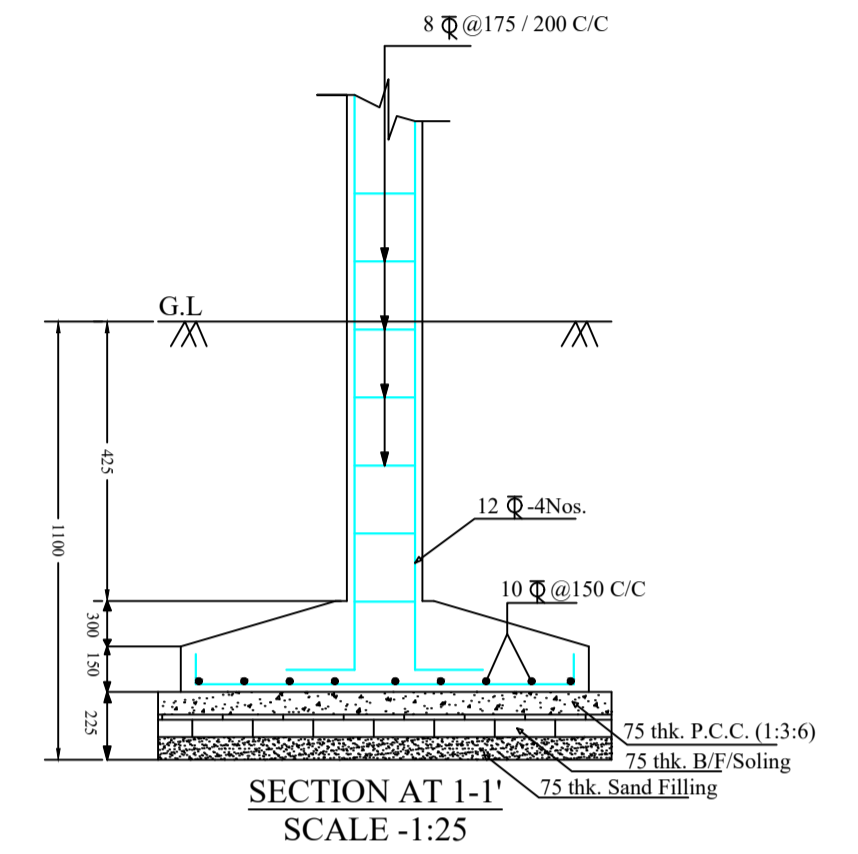

LTP NAME AND SIGNATURE	STRUCTURAL ENG'S NAME AND SIGNATURE	BUILDER NAME AND SIGNATURE	DIGITAL SIGNATURE
MD RAGIB SAYEED SINPC/ENG/0001/2017			