

SITE PLAN

FAR & Tenement Details (Table 4c-1)

Building	No. of Same Bldg	Total Built Up Area (Sq.mt.)	Proposed FAR Area (Sq.mt.)		Total FAR Area (Sq.mt.)	Total Consumed Additional FAR Area (Sq.mt.)	Trmnt (No.)
			Resi.	Commercial			
A1 (RESI COM)	1	390.48	130.16	260.32	390.48	390.48	03
Grand Total:	1	390.48	130.16	260.32	390.48	390.48	03

Proposal Basic Information

Proposal File No.	SINPC/BP/0298/W05/2022
Owner Name	OLEBHA
Khata No	10
Plot No	2454
Village Name	Khijri
Use	Mixed
SubUse	Resi+Comm

Required Parking (Table 7a)

Building Name	Type	SubUse	Area (Sq.mt.)	Units		Car			Visitors Car			TwoWheeler		
				Reqd.	Prop.	Reqd./Unit	Reqd.	Prop.	Reqd./Unit	Reqd.	Prop.	Reqd./Unit	Reqd.	Prop.
A1 (RESI COM)	Commercial	ResiComm Bldg	> 0	200	240.40	1	1	-	-	-	-	-	-	-
			> 0	200	240.40	-	-	-	-	-	-	1	3	-
			> 0	1	1.00	1	1	-	-	-	-	-	-	-
Residential	ResiComm Bldg	> 0	1	1.00	-	-	-	-	-	-	-	1	1	
		> 0	1	1.00	-	-	-	-	-	-	-	-	-	
		> 0	1	1.00	-	-	-	-	1	1	-	-	-	
Total:			-	-	-	2	2	-	-	1	3	-	4	4

Parking Check (Table 7b)

Vehicle Type	Reqd.		Prop.	
	No.	Area	No.	Area
Car	-	-	2	25.00
Total Car	2	25.00	2	25.00
Visitor's Car Parking	-	-	3	37.50
Total Visitor Parking	1	12.50	3	37.50
TwoWheeler	-	-	4	10.00
Total TwoWheeler	4	8.00	4	10.00
Total		45.50		82.50

AREA STATEMENT SIMDEGA NAGAR PANCHAYAT	VERSION NO: 1.0.62	
	VERSION DATE: 16/10/2020	
PROJECT DETAIL:		
Region: JHARKHAND URBAN LOCAL BODIES	Plot Use: Mixed	
District: SIMDEGA	Plot SubUse: Resi+Comm	
Authority: SIMDEGA NAGAR PANCHAYAT	PlotNearbyReligiousStructure: NA	
Inward No: SINPC/BP/0298/W05/2022	PlotSubPlot No: 2454	
Application Type: General Proposal	North: -	
Project Type: Building Permission	South: -	
Nature of Development: New	East: -	
Location of Development Area: Old Area	West: -	
AREA DETAILS:		
AREA OF PLOT (Minimum)	(A)	SQ.MT. 383.39
NET AREA OF PLOT(Gross Plot Area - Deduction from Gross Plot area)	(A-Deductions)	383.39
Deduction for Balance Plot Area(from Gross Plot Area)		
Common Plot		50.84
Total		50.84
BALANCE AREA OF PLOT(Net Plot Area - Recreational/Amenity space)	(A-Deductions)	332.54
PLOT AREA FOR COVERAGE(Net Plot Area)	(A-Deductions)	383.39
Plot Area for FAR (Net Plot Area + Road Widening Area)	(A-Deductions)	383.39
COVERAGE CHECK		
Permissible Coverage area ( 60.00 % )		230.03
Proposed Coverage Area ( 33.95 % )		130.16
Total Prop. Coverage Area ( 33.95 % )		130.16
Balance coverage area ( 26.05 % )		99.87
FAR CHECK		
Perm. FAR Area ( 2.00 )		766.78
Total Perm. FAR area		766.78
Residential FAR		130.16
Commercial FAR		260.32
Proposed FAR Area		390.48
Total Proposed FAR Area		390.48
Consumed FAR (Factor)		1.02
Balance FAR Area		376.30
BUILT UP AREA CHECK		
Total Proposed BuiltUp Area		390.48
ARCHITECT (Regd)		RAM RATAN SINGH
ENGINEER (Regd)		
SUPERVISOR (Regd)		
OWNER (Regd)		OLEBHA
DEVELOPMENT AUTHORITY		LOCAL BODY

COLOR INDEX	
PLOT BOUNDARY	Black
ABUTTING ROAD	Green
PROPOSED CONSTRUCTION	Red
COMMON PLOT	Yellow
ROAD WIDENING AREA	Orange
EXISTING (To be retained)	Blue
EXISTING (To be demolished)	Light Blue

Buildingwise Floor FAR Details

Floor Name	Building Name A1 (RESI COM)		Total	
	Proposed Built Up Area (Sq.mt.)	Proposed FAR Area (Sq.mt.)	Total Proposed Built Up Area (Sq.mt.)	Total FAR Area (Sq.mt.)
Ground Floor	130.16	130.16	130.16	130.16
First Floor	130.16	130.16	130.16	130.16
Second Floor	130.16	130.16	130.16	130.16
Terrace Floor	0.00	0.00	0.00	0.00
Total:	390.48	390.48	390.48	390.48

Building USE/SUBUSE Details

Building Name	Building Use	Building SubUse	Building Structure
A1 (RESI COM)	Commercial	ResiComm Bldg	Non-Highrise

LTP NAME AND SIGNATURE	STRUCTURAL ENG'S NAME AND SIGNATURE	BUILDER NAME AND SIGNATURE	DIGITAL SIGNATURE
RAM RATAN SINGH SINPC/DFTMN/0003/2020			

Proposal Basic Information	
Proposal File No.	SINPC/BP/0298/W05/2022
Owner Name	OLEBHA
Khata No	10
Plot No	2454
Village Name	Khijiri
Use	Mixed
SubUse	Resi+Comm

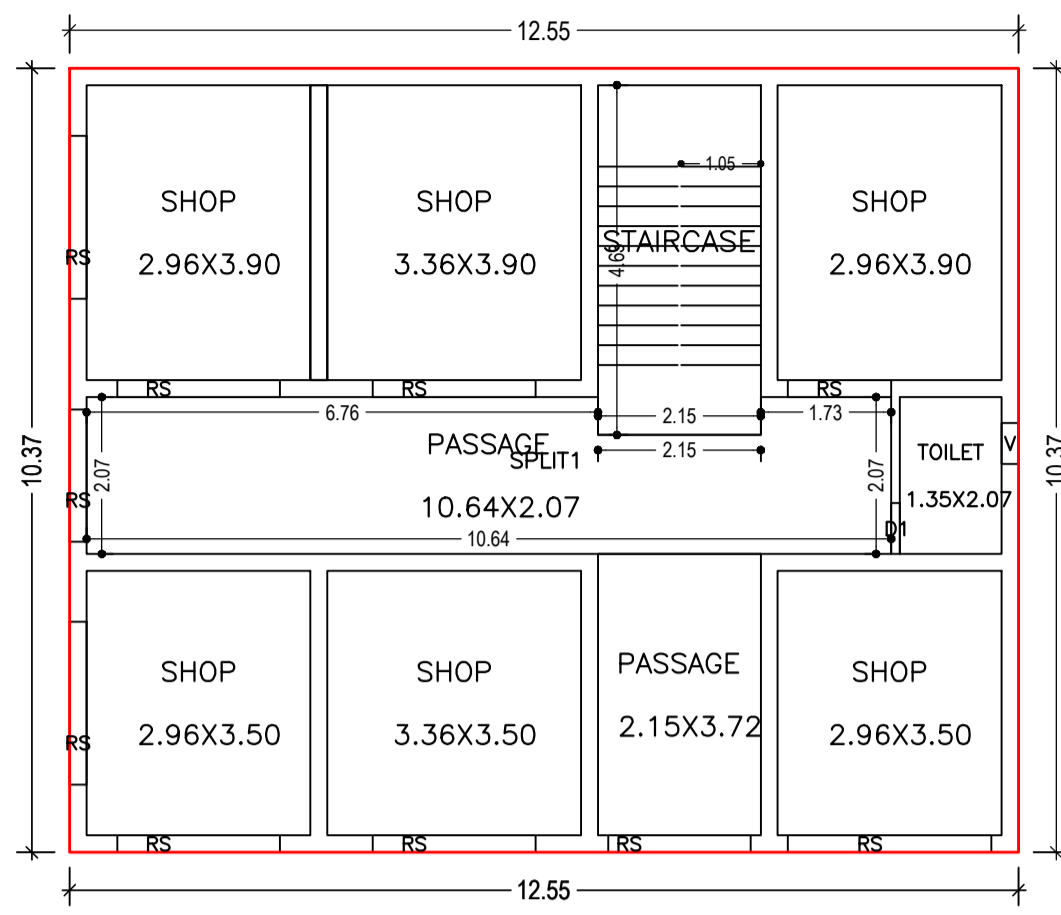

GROUND FLOOR PLAN  
(Proposed)  
(SCALE 1:100)

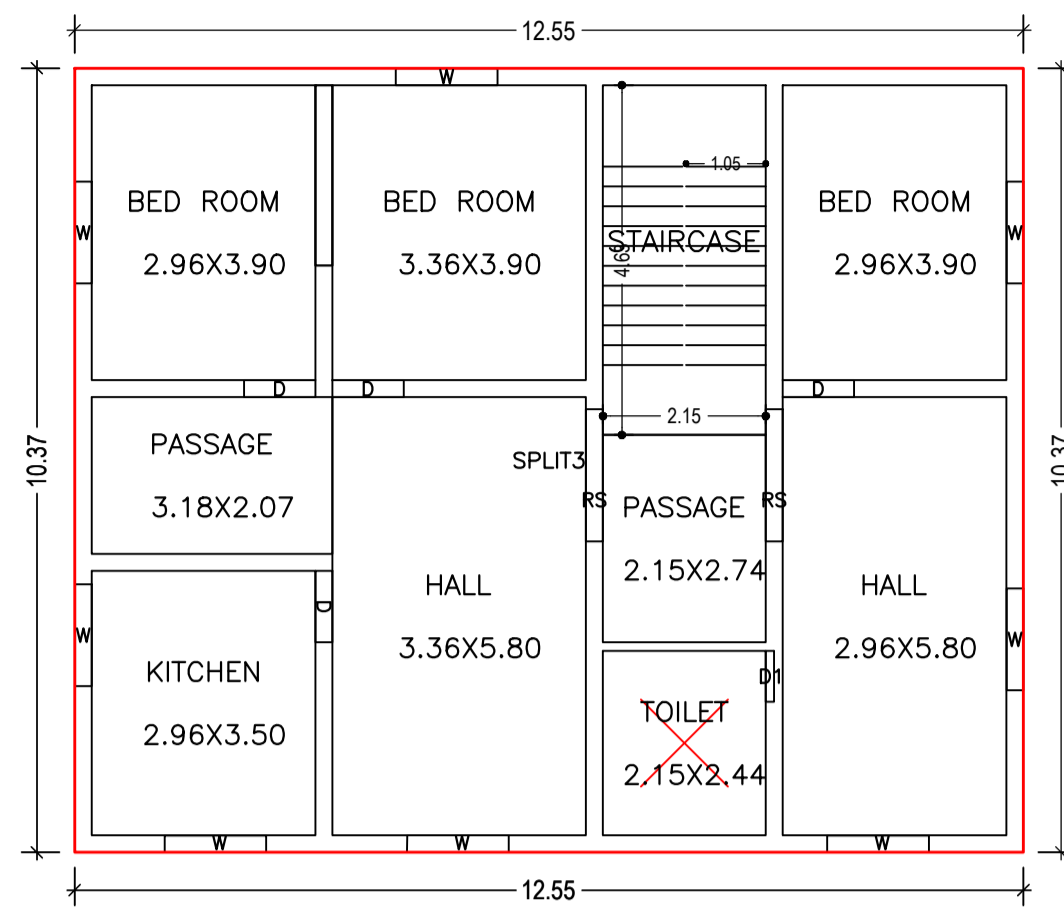

SECOND FLOOR PLAN  
(Proposed)  
(SCALE 1:100)

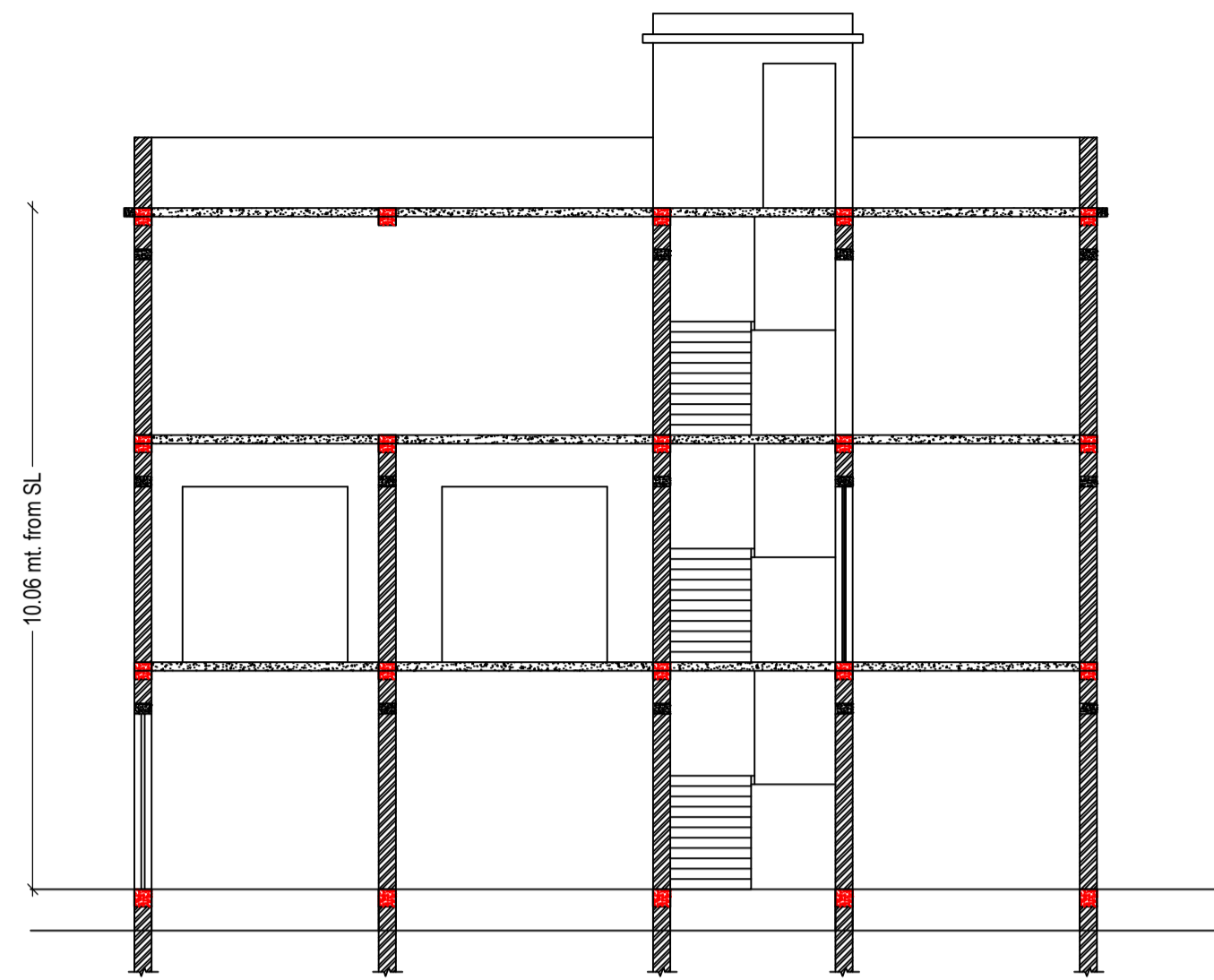

SECTION ON  
SCALE 1:100

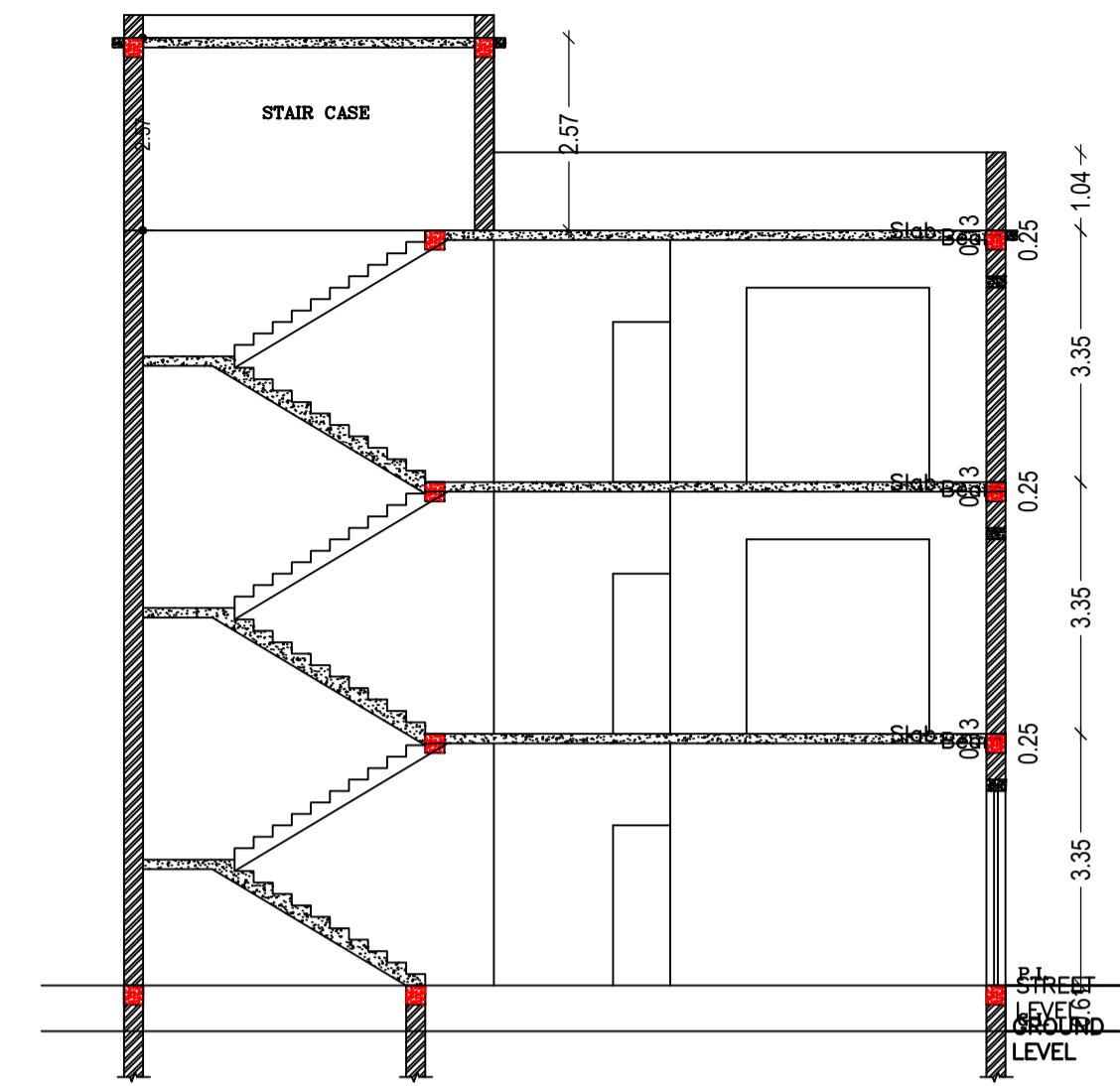

SECTION ON  
SCALE 1:100

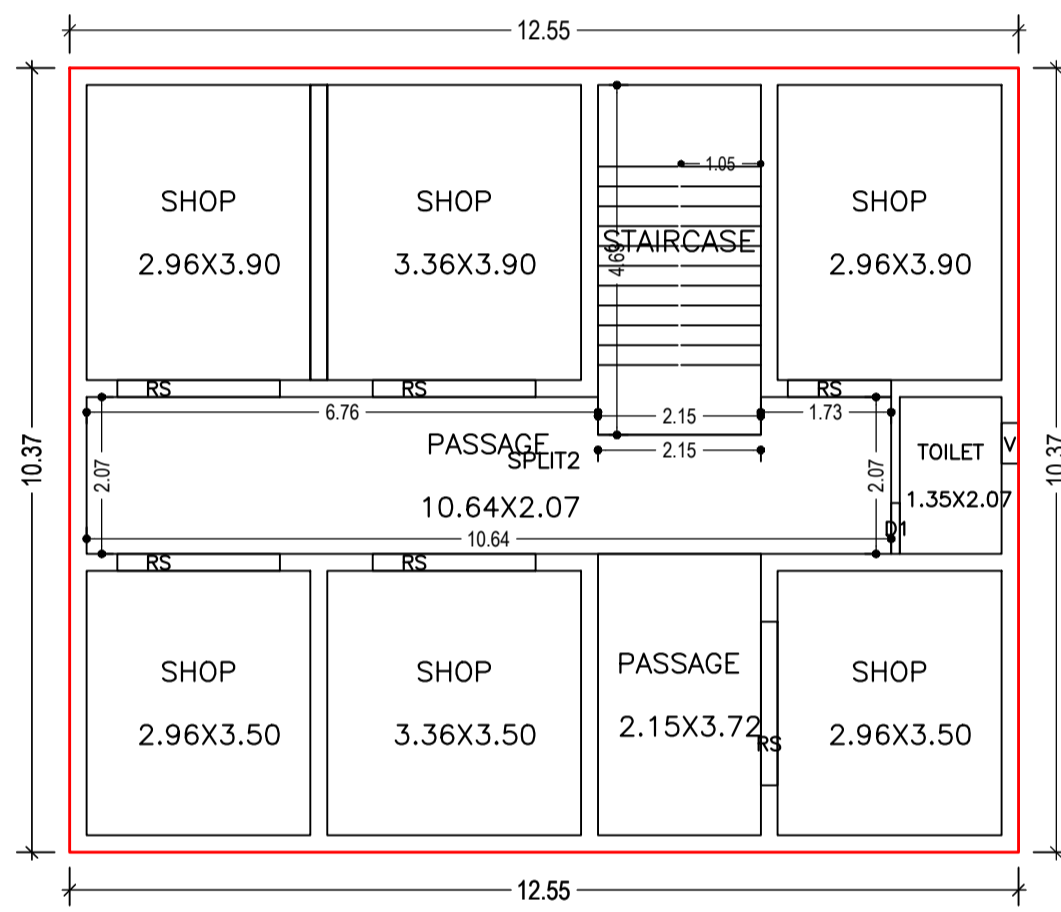

FIRST FLOOR PLAN  
(Proposed)  
(SCALE 1:100)

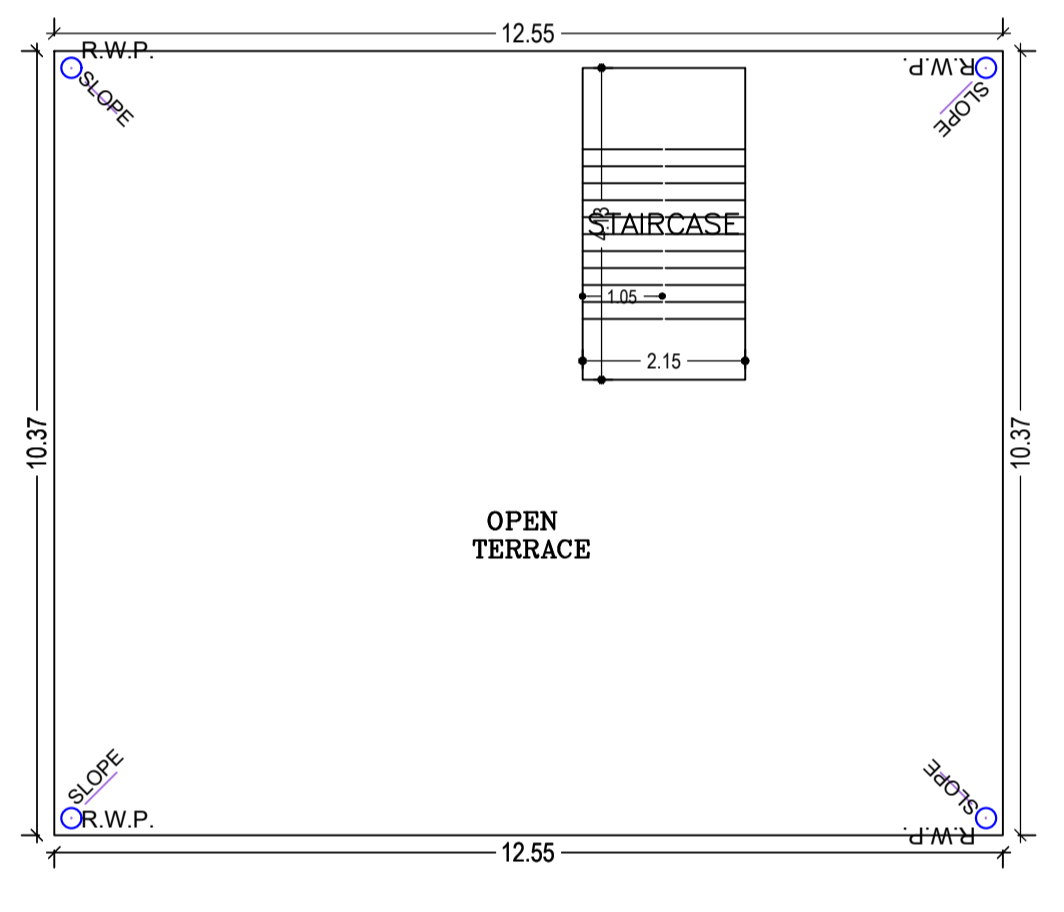

TERRACE FLOOR PLAN  
(SCALE 1:100)

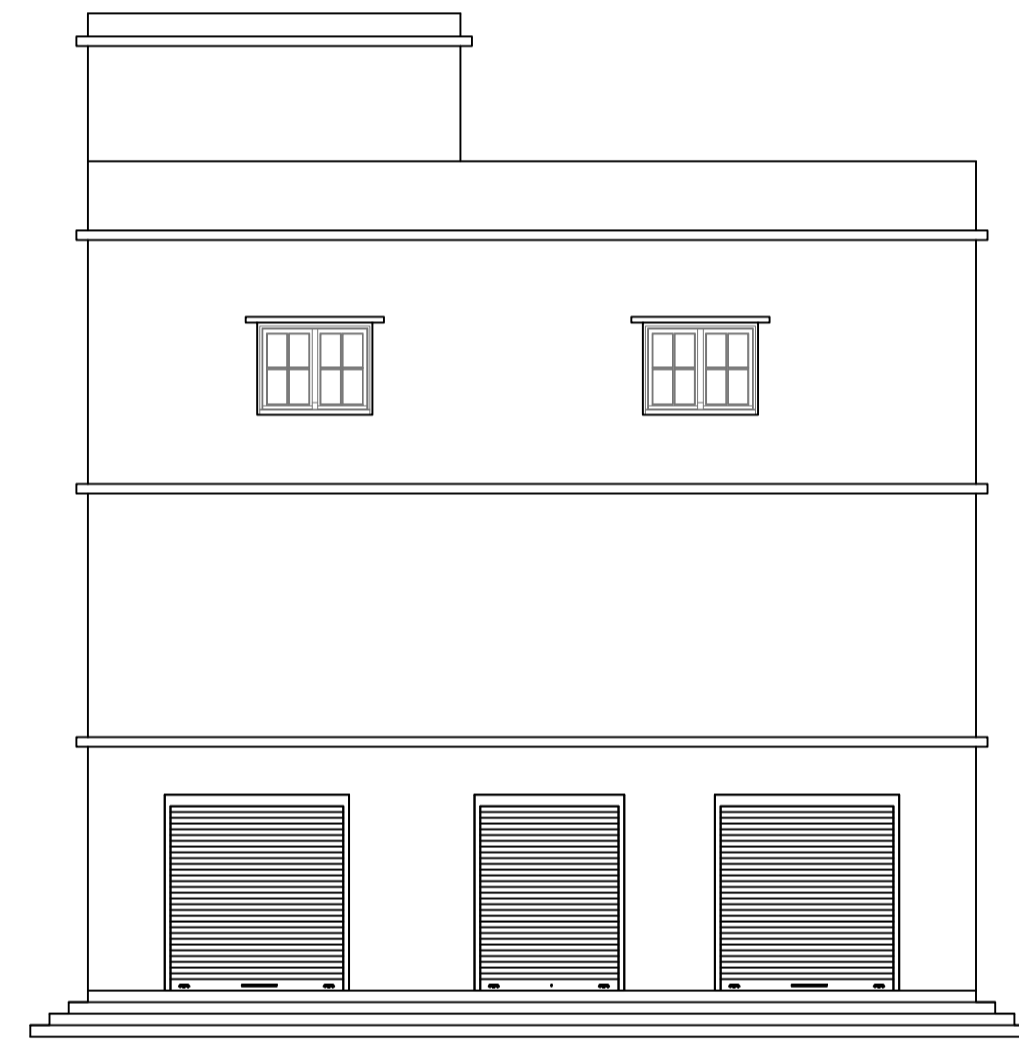

RIGHT SIDE ELEVATION  
SCALE 1:100

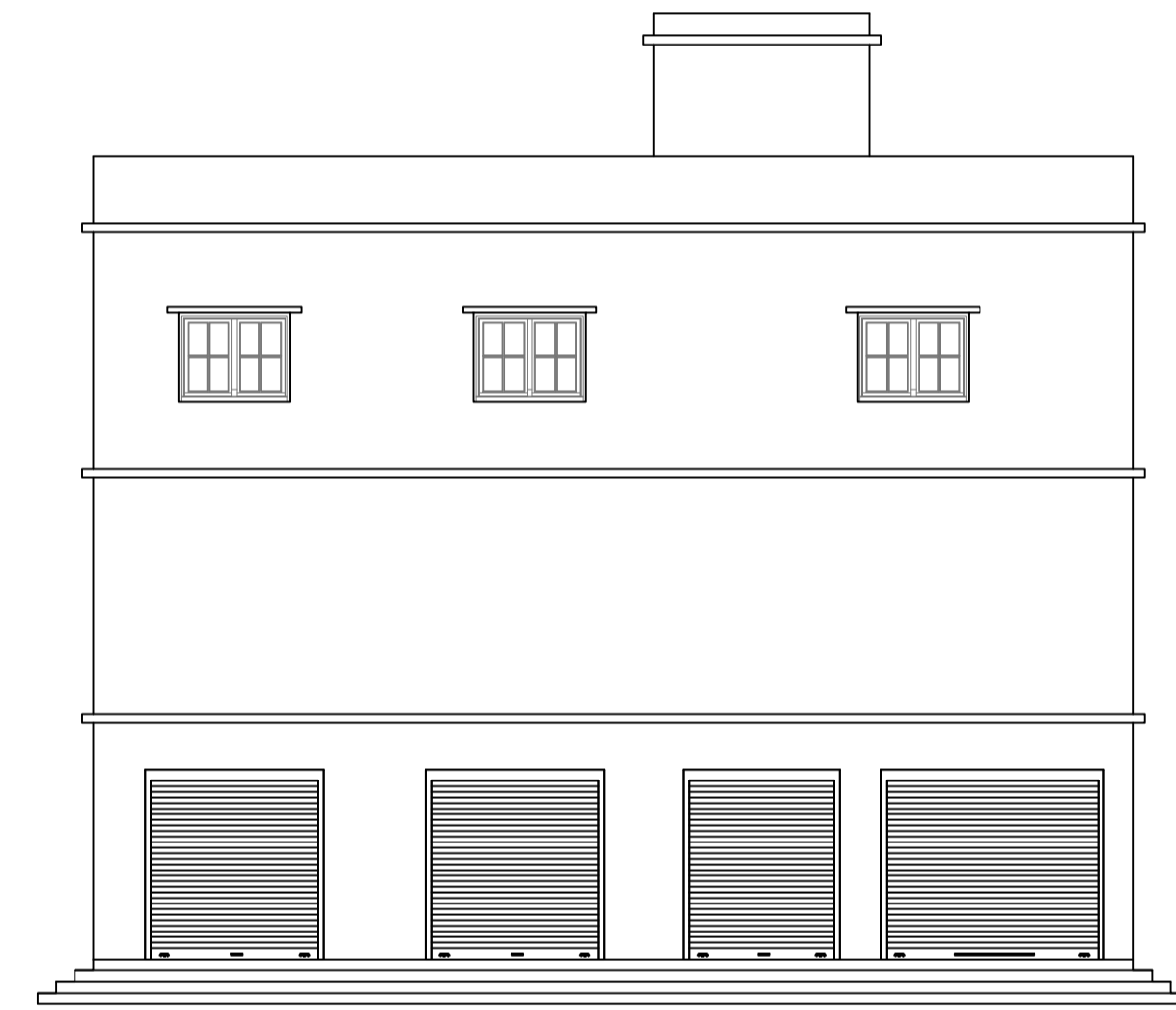

FRONT ELEVATION  
SCALE 1:100

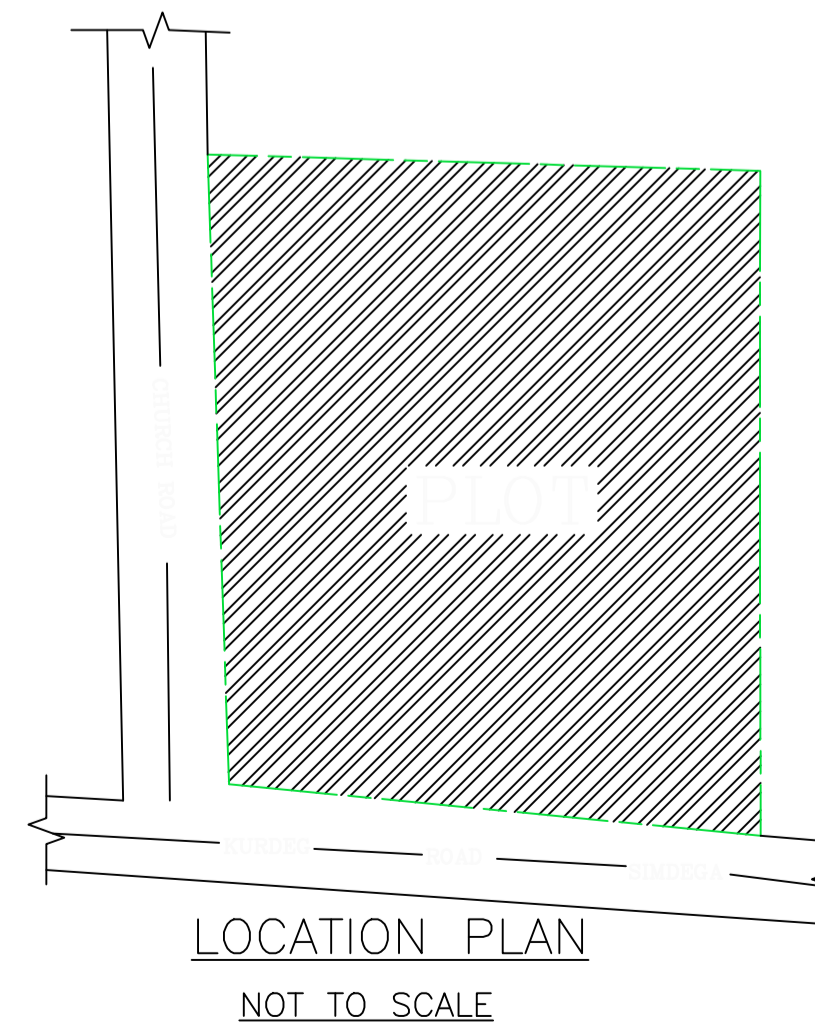
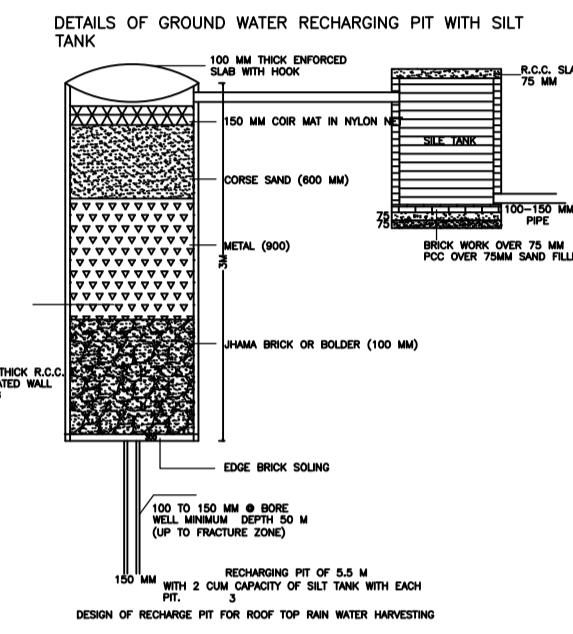
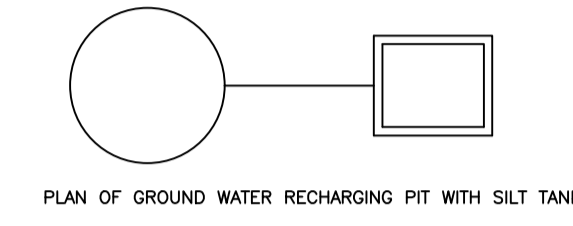

LOCATION PLAN  
NOT TO SCALE

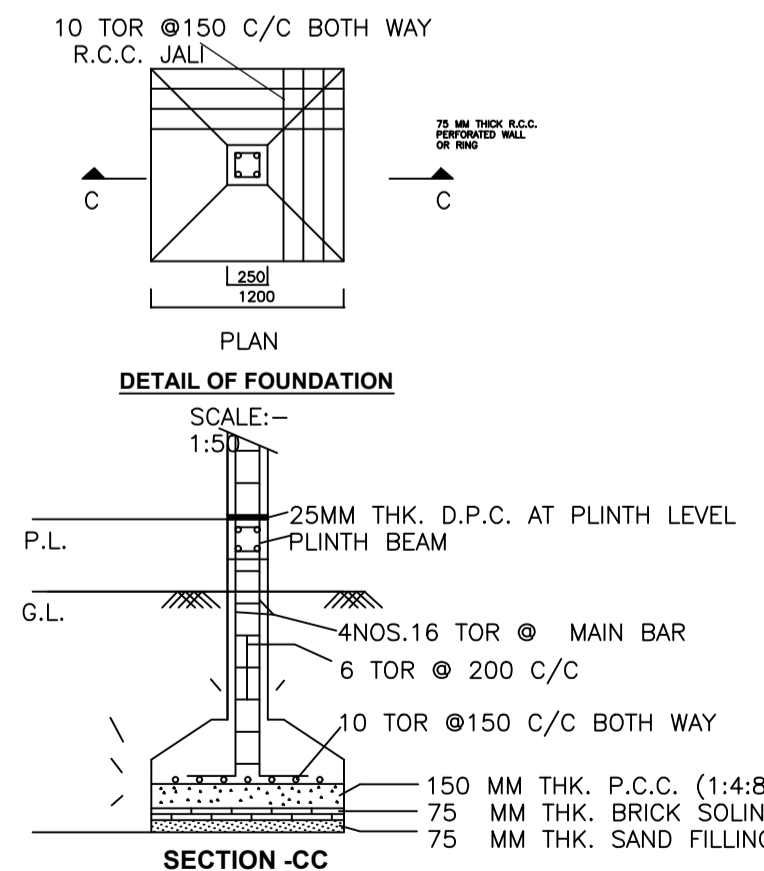

SECTION-CC

Building :A1 (RESI COM)

Floor Name	Total Built Up Area (Sq.mt.)	Proposed FAR Area (Sq.mt.)		Total FAR Area (Sq.mt.)	Total Consumed Additional FAR Area (Sq.mt.)	Tnmt (No.)
		Resi.	Commercial			
Ground Floor	130.16	0.00	130.16	130.16	130.16	01
First Floor	130.16	0.00	130.16	130.16	130.16	01
Second Floor	130.16	130.16	0.00	130.16	130.16	01
Terrace Floor	0.00	0.00	0.00	0.00	0.00	00
Total :	390.48	130.16	260.32	390.48	390.48	03
Total Number of Same Buildings	1					
Total :	390.48	130.16	260.32	390.48	390.48	03

SCHEDULE OF DOOR:

BUILDING NAME	NAME	LENGTH	HEIGHT	NOS
A1 (RESI COM)	D1	0.67	2.10	03
A1 (RESI COM)	D	0.94	2.10	04
A1 (RESI COM)	RS	1.37	2.10	02
A1 (RESI COM)	RS	1.75	2.10	03
A1 (RESI COM)	RS	1.88	2.10	01
A1 (RESI COM)	RS	2.15	2.10	10
A1 (RESI COM)	RS	2.16	2.10	01
A1 (RESI COM)	RS	2.69	2.10	01

SCHEDULE OF WINDOW/VENTILATION:

BUILDING NAME	NAME	LENGTH	HEIGHT	NOS
A1 (RESI COM)	V	0.54	1.20	02
A1 (RESI COM)	W	1.35	1.20	08

UnitBUA Table for Building :A1 (RESI COM)

FLOOR	Name	UnitBUA Type	UnitBUA Area	Carpet Area	No. of Rooms	No. of Tenement
GROUND FLOOR PLAN	SPLIT1	SHOP	108.27	107.39	9	1
FIRST FLOOR PLAN	SPLIT2	SHOP	108.27	107.39	9	1
SECOND FLOOR PLAN	SPLIT3	FLAT	108.27	107.73	9	1
Total:	-	-	324.81	322.51	27	3

LTP NAME AND SIGNATURE	STRUCTURAL ENG'S NAME AND SIGNATURE	BUILDER NAME AND SIGNATURE	DIGITAL SIGNATURE
RAM RATAN SINGH SINPC/DFTMN/0003/2020			

Proposal Basic Information	
Proposal File No.	SINPC/BP/0298/W05/2022
Owner Name	OLEBHA
Khata No	10
Plot No	2454
Village Name	Khijri
Use	Mixed
SubUse	Resi+Comm

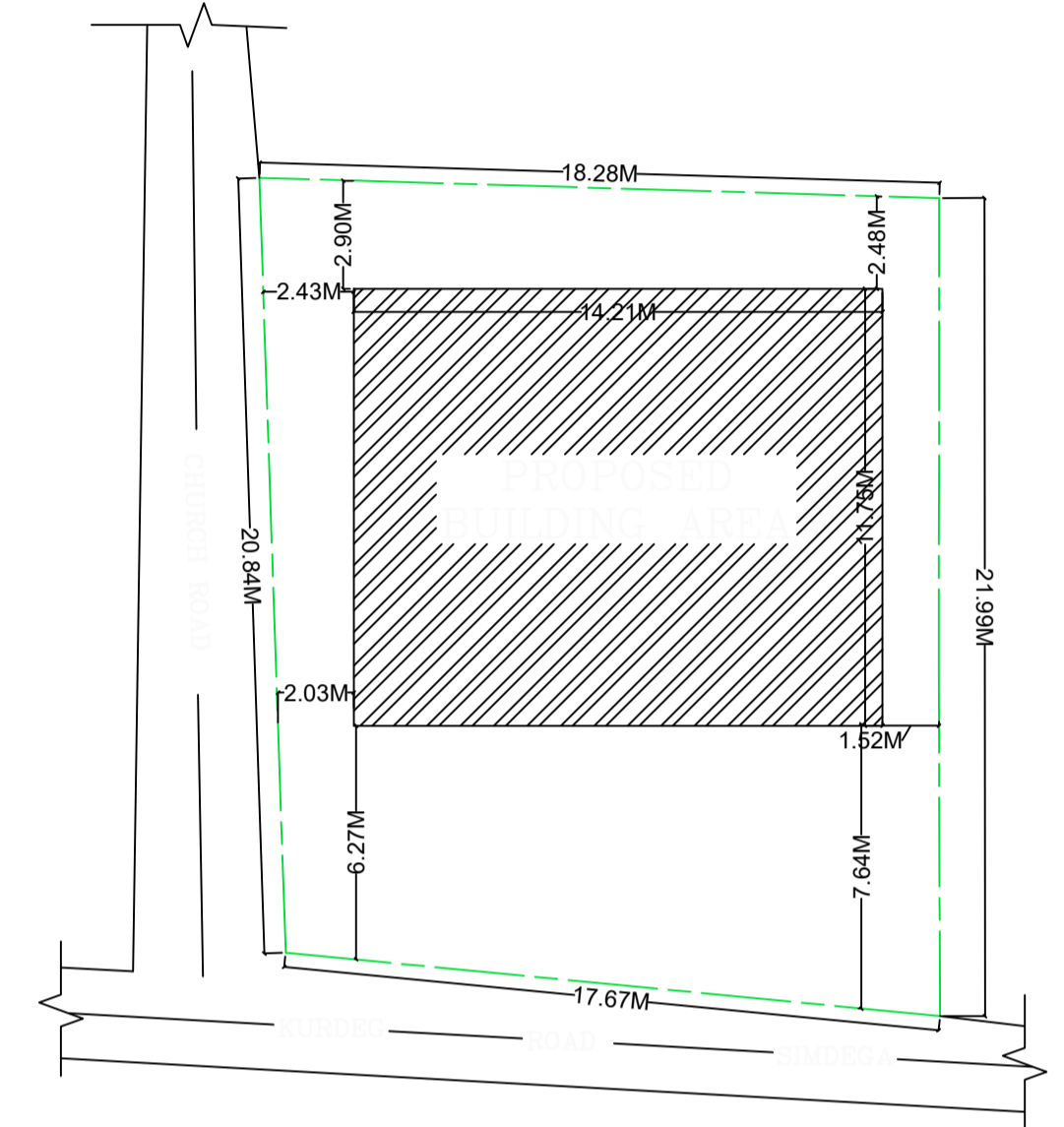

KEY PLAN  
SCALE 1:200

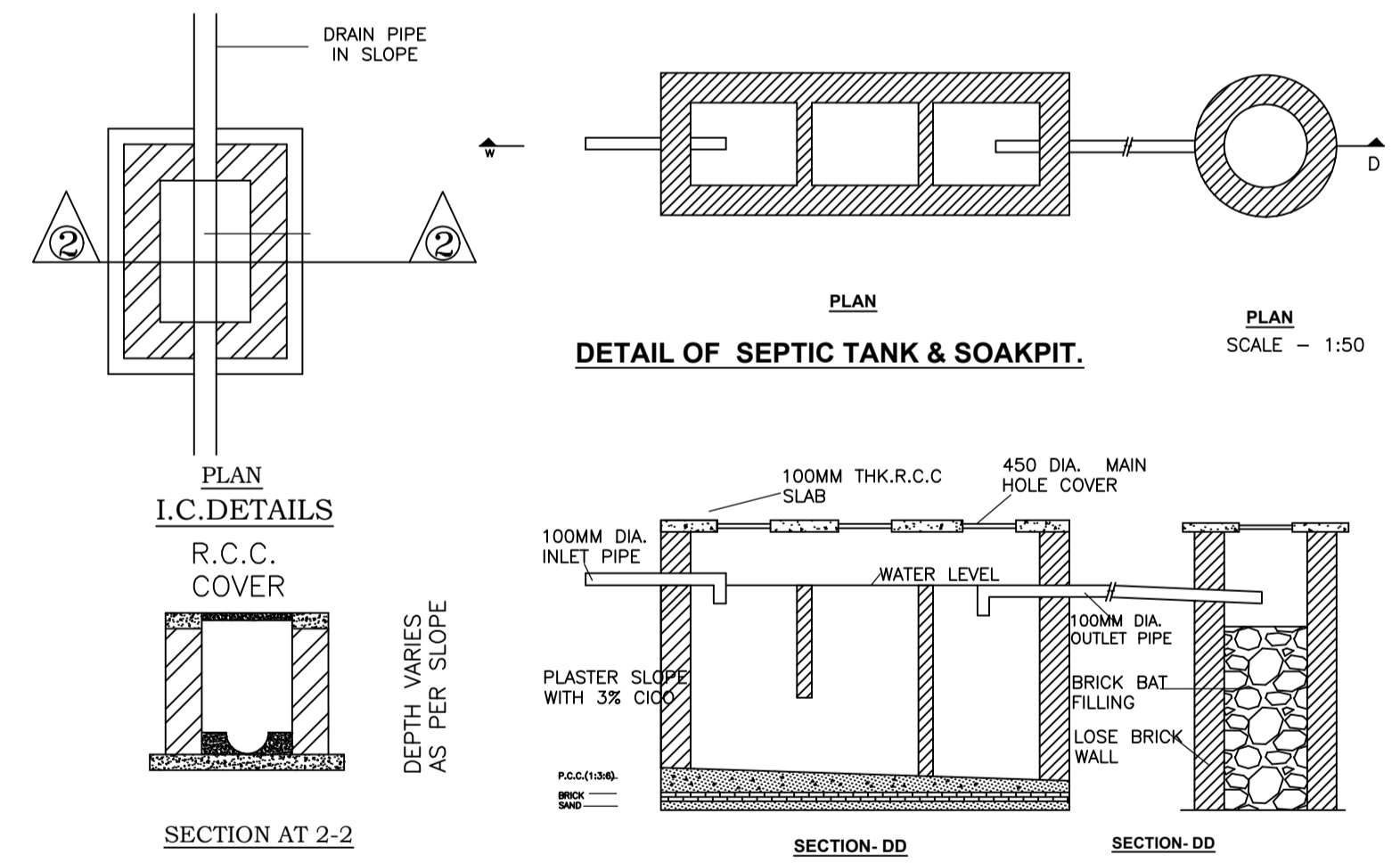

DETAIL OF SEPTIC TANK & SOAKPIT.  
SCALE - 1:50

LTP NAME AND SIGNATURE	STRUCTURAL ENG'S NAME AND SIGNATURE	BUILDER NAME AND SIGNATURE	DIGITAL SIGNATURE
RAM RATAN SINGH SINPC/DFTMN/0003/2020			