

SITE PLAN

FAR & Tenement Details (Table 4c-1)

Building	No. of Same Bldg	Total Built Up Area (Sq.mt.)	Proposed FAR Area (Sq.mt.) Resi.	Total FAR Area (Sq.mt.)	Total Consumed Additional FAR Area (Sq.mt.)	Tnmt (No.)
A1 (RESIDENSE)	1	188.60	188.60	188.60	188.60	02
Grand Total	1	188.60	188.60	188.60	188.60	02

Proposal Basic Information

Proposal File No.	SINPC/BP/0340/W06/2022
Owner Name	SRI LIBNUS LAKRA
Khata No	152
Plot No	2174
Village Name	Khijri
Use	Residential
SubUse	Bungalow/ Dwelling / Non Apartment

Required Parking (Table 7a)

Building Name	Type	SubUse	Area (Sq.mt.)	Units		Car		Visitors Car		TwoWheeler	
				Reqd.	Prop.	Reqd./Unit	Prop.	Reqd./Unit	Prop.	Reqd./Unit	Prop.
A1 (RESIDENSE)	Residential	Bungalow/ Dwelling / Non Apartment	> 0	1	2.00	1	2	-	-	-	-
			> 0	1	2.00	-	-	1	1	-	-
Total			-	-	-	-	2	2	-	1	1

Parking Check (Table 7b)

Vehicle Type	Reqd.		Prop.	
	No.	Area	No.	Area
Car	-	-	2	25.00
Total Car	2	25.00	2	25.00
Visitor's Car Parking	-	-	1	12.50
Total Visitor Parking	1	12.50	1	12.50
TwoWheeler	-	-	2	5.00
Total TwoWheeler	-	-	2	5.00
Total		37.50		47.50

AREA STATEMENT SIMDEGA NAGAR PANCHAYAT	VERSION NO: 1.0.65	VERSION DATE: 16/10/2020
PROJECT DETAIL:	Region: JHARKHAND URBAN LOCAL BODIES	Plot Use: Residential
	District: SIMDEGA	Plot SubUse: Bungalow/ Dwelling / Non Apartment
	Authority: SIMDEGA NAGAR PANCHAYAT	PlotNearby/ReligiousStructure: NA
	Inward No: SINPC/BP/0340/W06/2022	Plot/SubPlot No: 2174
	Application Type: General Proposal	North: -
	Project Type: Building Permission	South: -
	Nature of Development: New	East: -
	Location of Development Area: Old Area	West: -
AREA DETAILS:		SQ.MT.
AREA OF PLOT (Minimum)	(A)	238.78
Deduction for NetPlot Area		
Surrender Free of Cost		25.78
Total		25.78
NET AREA OF PLOT(Gross Plot Area - Deduction from Gross Plot area)	(A-Deductions)	213.00
Deduction for Balance Plot Area(from Gross Plot Area)		
Surrender Free of Cost		25.78
Common Plot		24.83
Total		50.61
BALANCE AREA OF PLOT(Net Plot Area - Recreational/Amenity space)	(A-Deductions)	188.18
PLOT AREA FOR COVERAGE(Net Plot Area)	(A-Deductions)	213.00
Plot Area for FAR (Net Plot Area + RoadWidening Area)	(A-Deductions)	238.78
COVERAGE CHECK		
Permissible Coverage area (70.00 %)		149.10
Proposed Coverage Area (44.22 %)		94.20
Total Prop. Coverage Area (44.22 %)		94.20
Balance coverage area (25.77 %)		54.90
FAR CHECK		
Perm. FAR Area (1.500)		358.17
Total Perm. FAR area		358.17
Residential FAR		188.60
Proposed FAR Area		188.60
Total Proposed FAR Area		188.60
Consumed FAR (Factor)		0.79
Balance FAR Area		169.57
BUILT UP AREA CHECK		
Total Proposed BuiltUp Area		188.60
ARCHITECT (Regd)	MAHENDRA MEHTA	
ENGINEER (Regd)		
SUPERVISOR (Regd)		
OWNER (Regd)	SRI LIBNUS LAKRA	
DEVELOPMENT AUTHORITY	LOCAL BODY	

COLOR INDEX	
PLOT BOUNDARY	Black
ABUTTING ROAD	Green
PROPOSED CONSTRUCTION	Red
COMMON PLOT	Yellow
ROAD WIDENING AREA	Blue
EXISTING (To be retained)	Blue
EXISTING (To be demolished)	Yellow

Buildingwise Floor FAR Details

Floor Name	Building Name A1 (RESIDENSE)		Total	
	Proposed Built Up Area (Sq.mt.)	Proposed FAR Area (Sq.mt.)	Total Proposed Built Up Area (Sq.mt.)	Total FAR Area (Sq.mt.)
Ground Floor	94.20	94.20	94.20	94.20
First Floor	94.40	94.40	94.40	94.40
Terrace Floor	0.00	0.00	0.00	0.00
Total	188.60	188.60	188.60	188.60

Building USE/SUBUSE Details

Building Name	Building Use	Building SubUse	Building Structure
A1 (RESIDENSE)	Residential	Bungalow/ Dwelling / Non Apartment	Non-Highrise

LTP NAME AND SIGNATURE	STRUCTURAL ENG'S NAME AND SIGNATURE	BUILDER NAME AND SIGNATURE	DIGITAL SIGNATURE
MAHENDRA MEHTA SINPC/DFTMN/002/2022			

Proposal Basic Information

Proposal File No.	SINPC/BP/0340/W06/2022
Owner Name	SRI LIBNUS LAKRA
Khata No	152
Plot No	2174
Village Name	Khijri
Use	Residential
SubUse	Bungalow/ Dwelling / Non Apartment

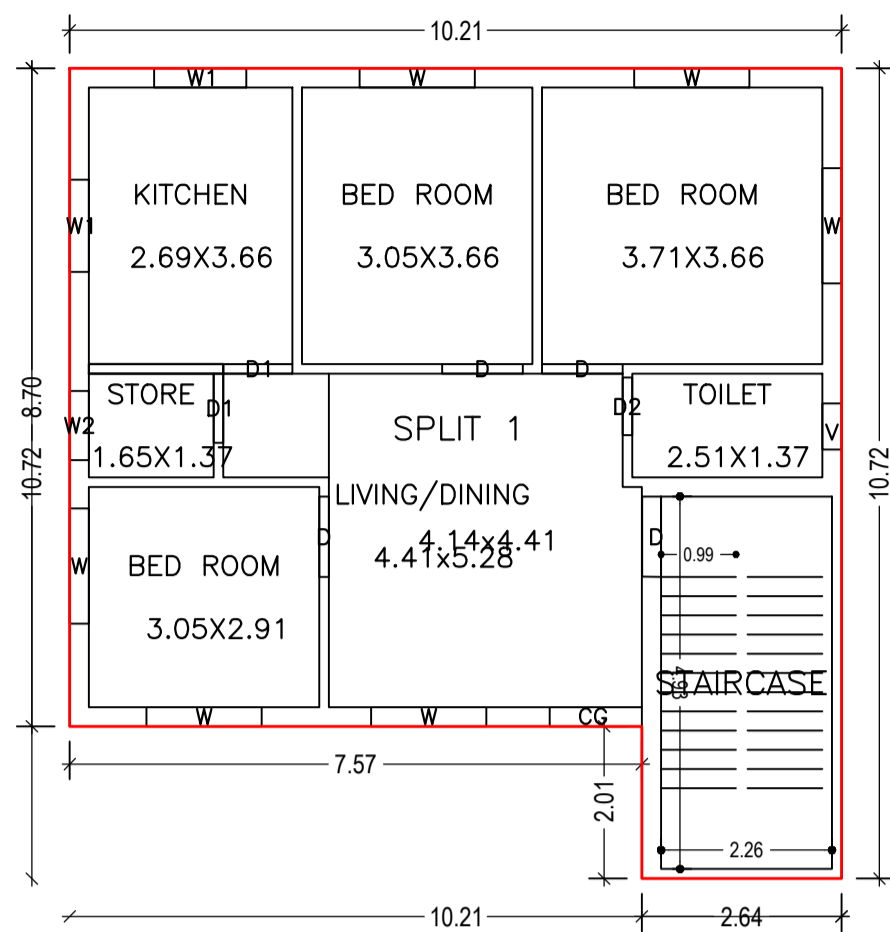

GROUND FLOOR PLAN (Proposed) (SCALE 1:100)

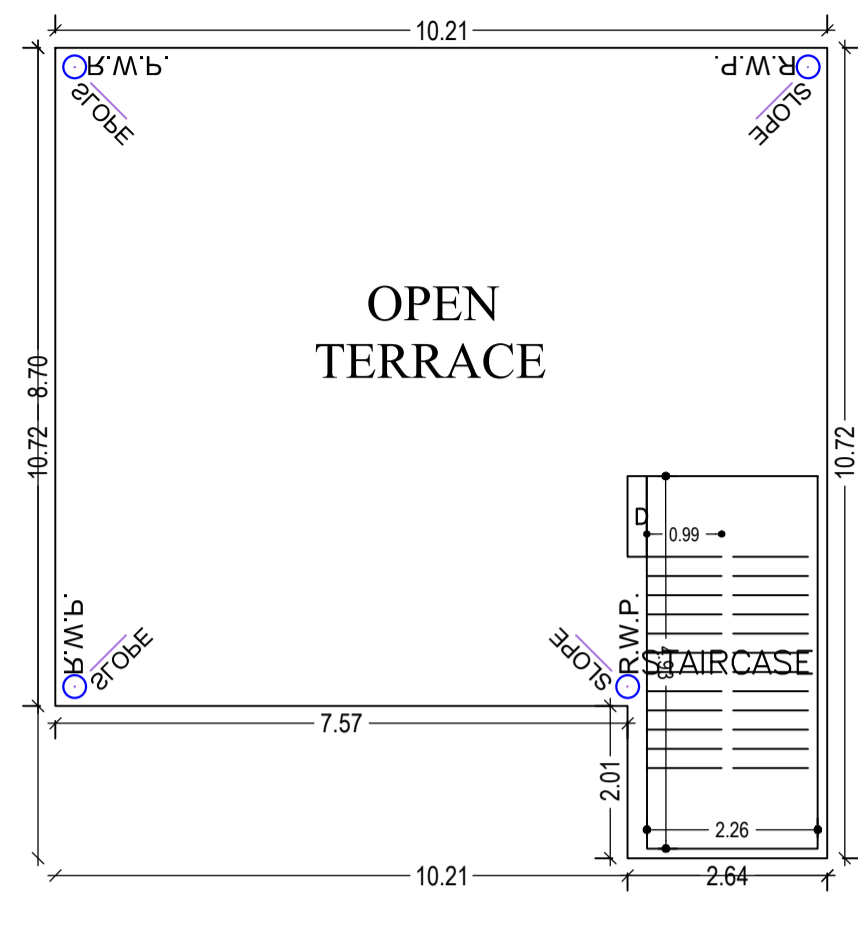

TERRACE FLOOR PLAN (SCALE 1:100)



FRONT ELEVATION (SCALE 1:100)

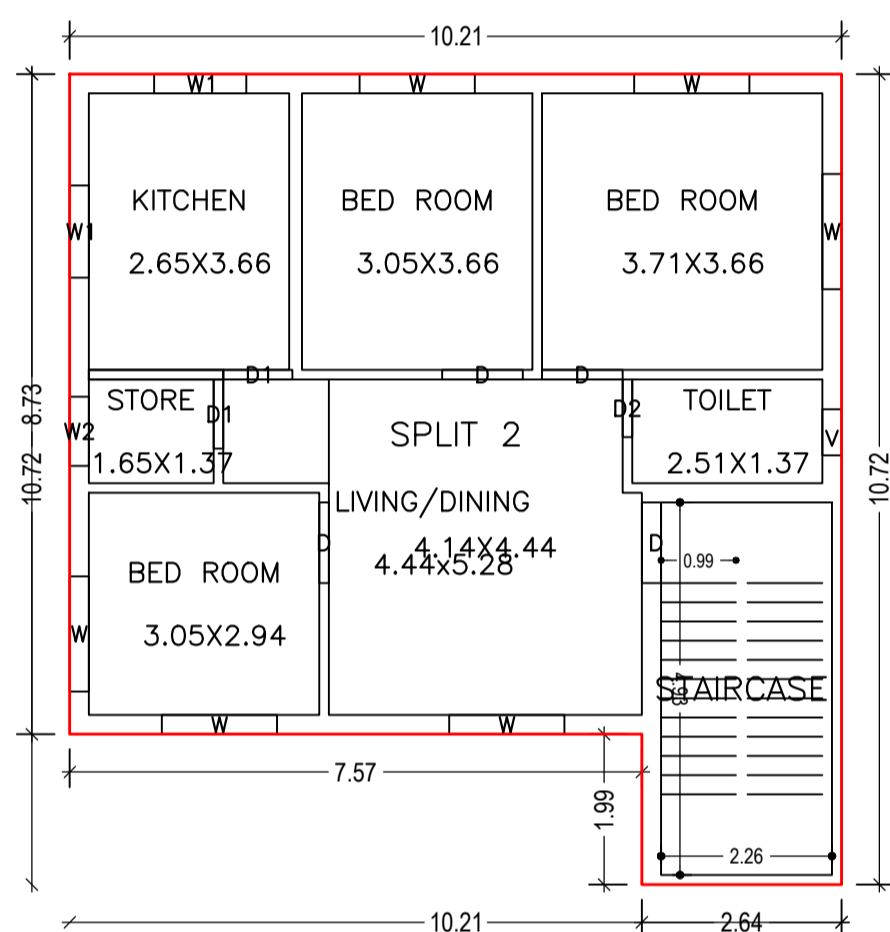

FIRST FLOOR PLAN (Proposed) (SCALE 1:100)

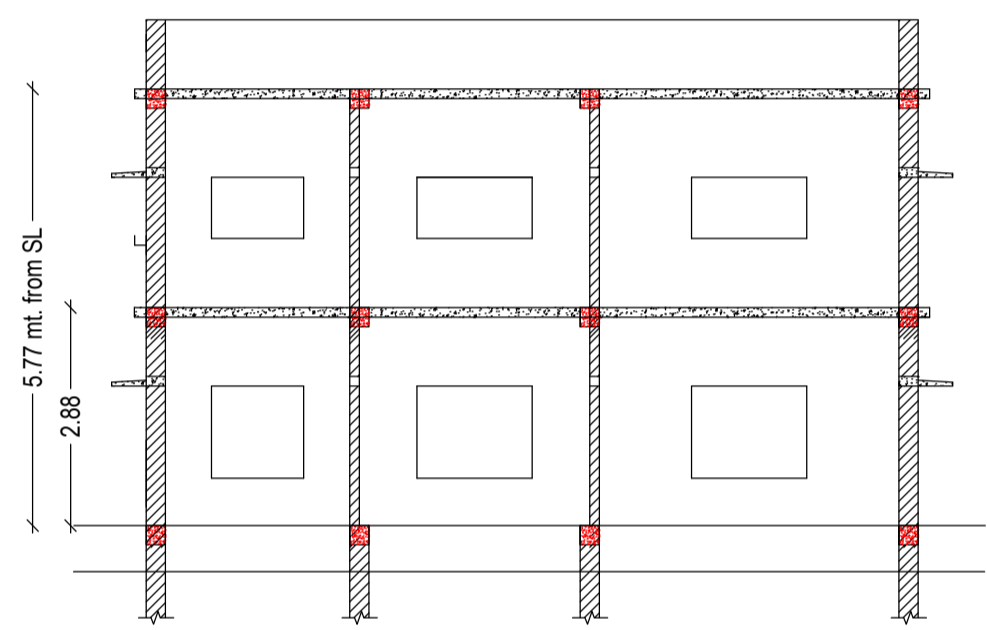

SECTION AT-X-X (SCALE 1:100)

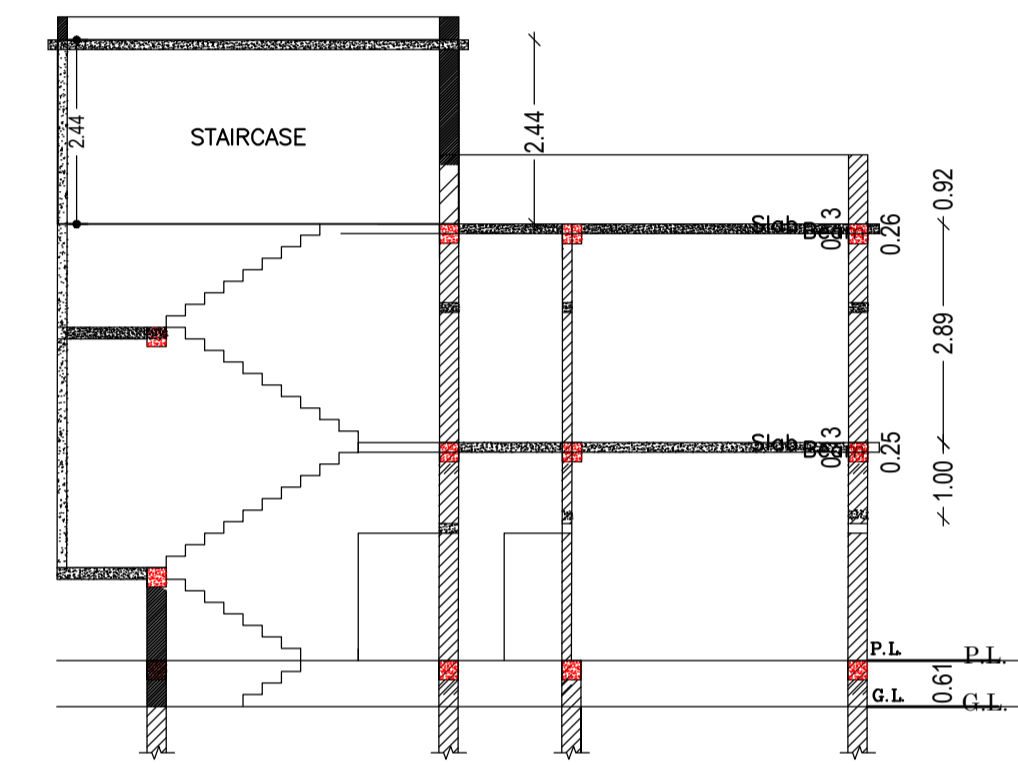

SECTION ON Y-Y (SCALE 1:100)



LEFT SIDE ELEVATION (SCALE 1:100)

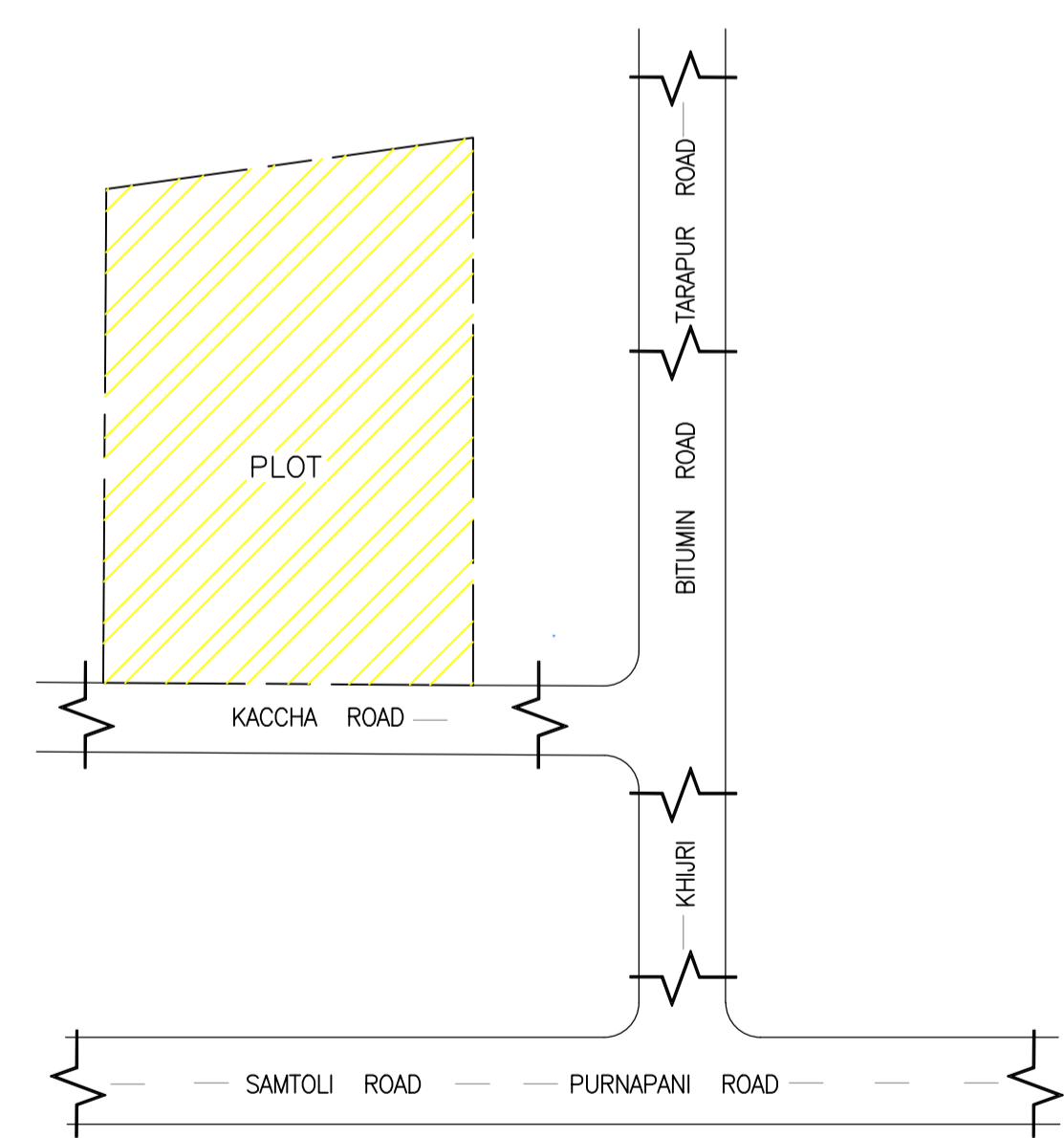

LOCATION PLAN (NOT TO SCALE)

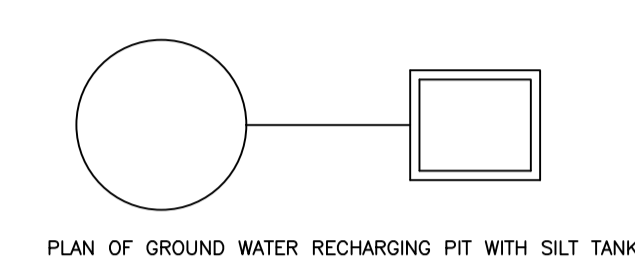

PLAN OF GROUND WATER RECHARGING PIT WITH SILT TANK

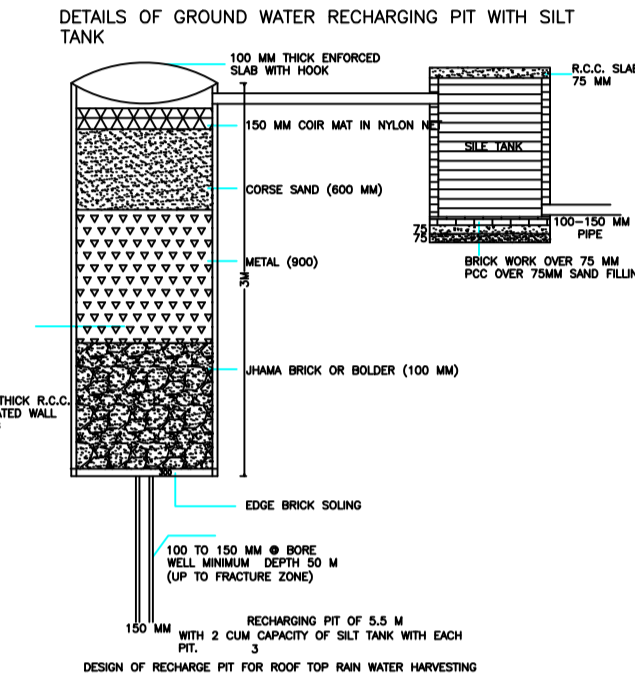

DETAILS OF GROUND WATER RECHARGING PIT WITH SILT TANK

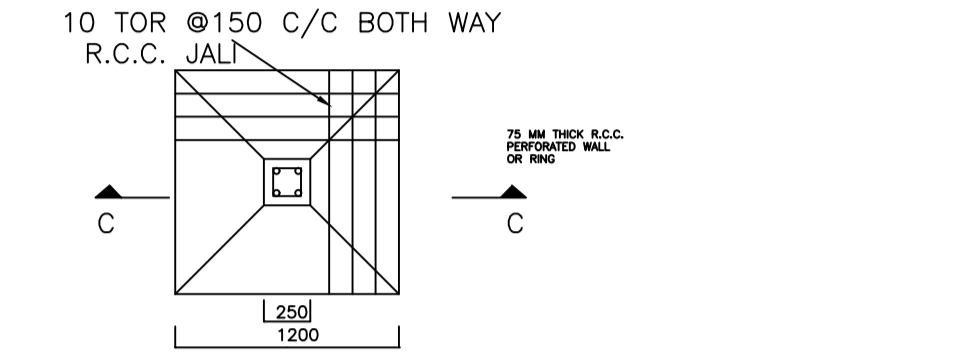

SECTION-CC (DETAIL OF FOUNDATION)

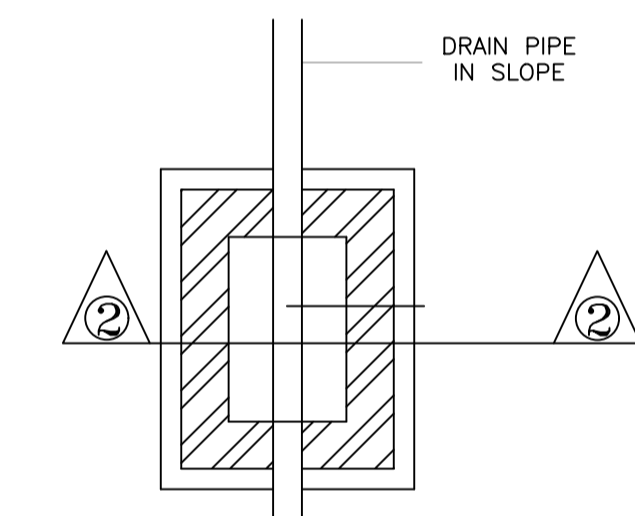

PLAN I.C. DETAILS (R.C.C. COVER)

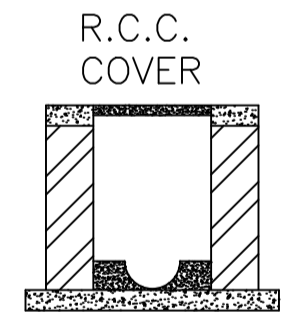

SECTION AT 2-2

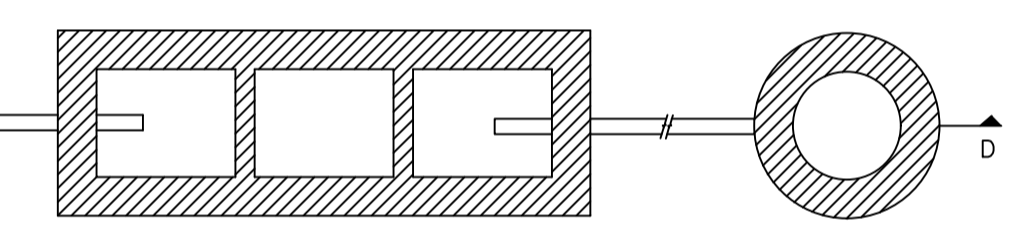

PLAN

PLAN (SCALE - 1:50)

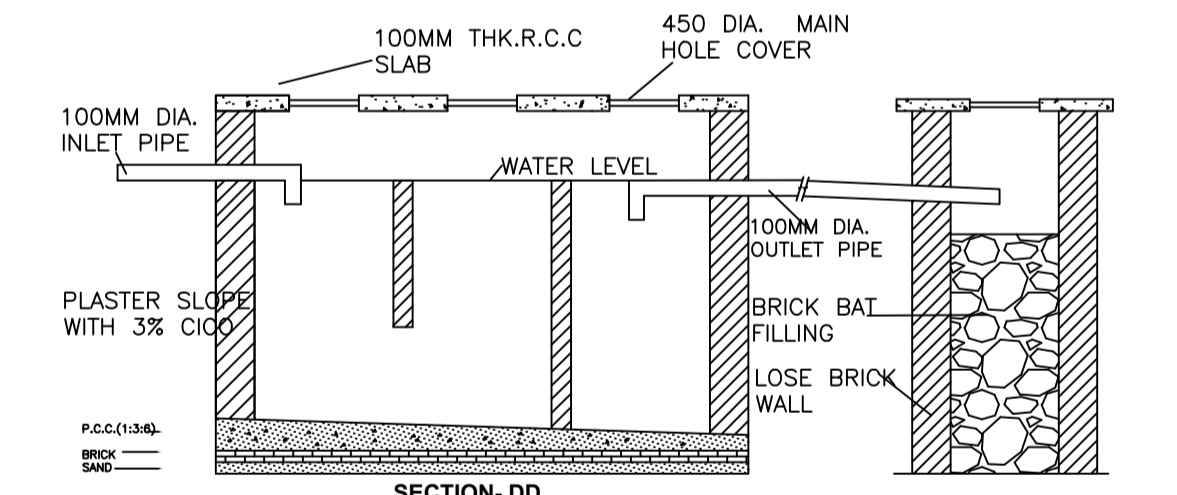

SECTION-DD (DETAIL OF SEPTIC TANK & SOAKPIT)

SITE PLAN (SCALE 1:100)

Building :A1 (RESIDENSE)

Floor Name	Total Built Up Area (Sq.mt.)	Proposed FAR Area (Sq.mt.)	Total FAR Area (Sq.mt.)	Total Consumed Additional FAR Area (Sq.mt.)	Tnmt (No.)
Ground Floor	94.20	94.20	94.20	94.20	01
First Floor	94.40	94.40	94.40	94.40	01
Terrace Floor	0.00	0.00	0.00	0.00	00
Total :	188.60	188.60	188.60	188.60	02
Total Number of Same Buildings	1				
Total :	188.60	188.60	188.60	188.60	02

SCHEDULE OF DOOR:

BUILDING NAME	NAME	LENGTH	HEIGHT	NOS
A1 (RESIDENSE)	D2	0.76	2.10	02
A1 (RESIDENSE)	D1	0.91	2.10	04
A1 (RESIDENSE)	D	1.07	2.10	08
A1 (RESIDENSE)	CG	1.22	2.10	01

SCHEDULE OF WINDOW/VENTILATION:

BUILDING NAME	NAME	LENGTH	HEIGHT	NOS
A1 (RESIDENSE)	V	0.61	1.20	02
A1 (RESIDENSE)	W2	0.91	1.20	02
A1 (RESIDENSE)	W1	1.22	1.20	04
A1 (RESIDENSE)	W	1.52	1.20	12

UnitBUA Table for Building :A1 (RESIDENSE)

FLOOR	Name	UnitBUA Type	UnitBUA Area	Carpet Area	No. of Rooms	No. of Tenement
GROUND FLOOR PLAN	SPLIT 1	FLAT	72.28	72.05	7	1
FIRST FLOOR PLAN	SPLIT 2	FLAT	72.46	72.24	7	1
Total:	-	-	144.74	144.29	14	2

LTP NAME AND SIGNATURE	STRUCTURAL ENG'S NAME AND SIGNATURE	BUILDER NAME AND SIGNATURE	DIGITAL SIGNATURE
MAHENDRA MEHTA SINPC/DFTMN/0002/2022			