

FAR & Tenement Details (Table 4c-1)

| Building | No. of Same Bldg | Total Built Up Area (Sq.mt.) | Proposed FAR Area (Sq.mt.) Resi. | Total FAR Area (Sq.mt.) | Total Consumed Additional FAR Area (Sq.mt.) | Tnmt (No.) |
|----------------|------------------|------------------------------|----------------------------------|-------------------------|---|------------|
| A1 (RESIDENCE) | 1 | 59.40 | 59.40 | 59.40 | 59.40 | 01 |
| Grand Total : | 1 | 59.40 | 59.40 | 59.40 | 59.40 | 01 |

Proposal Basic Information

| | |
|-------------------|------------------------------------|
| Proposal File No. | SINPC/BP/0350/W03/2022 |
| Owner Name | SUHATI KULLU |
| Khata No | 73 |
| Plot No | 539 |
| Village Name | Saldega |
| Use | Residential |
| SubUse | Bungalow/ Dwelling / Non Apartment |

AREA STATEMENT SIMDEGA NAGAR PANCHAYAT

VERSION NO: 1.0.64
VERSION DATE: 16/10/2020

| | |
|--|---|
| Region: JHARKHAND URBAN LOCAL BODIES | Plot Use: Residential |
| District: SIMDEGA | Plot SubUse: Bungalow/ Dwelling / Non Apartment |
| Authority: SIMDEGA NAGAR PANCHAYAT | PlotNearbyReligiousStructure: NA |
| Inward No: SINPC/BP/0350/W03/2022 | PlotSubPlot No: 539 |
| Application Type: General Proposal | North: - |
| Project Type: Building Permission | South: - |
| Nature of Development: New | East: - |
| Location of Development Area: Old Area | West: - |

| | | | |
|--|----------------|--------|--------|
| AREA OF PLOT (Minimum) | (A) | SQ.MT. | 270.13 |
| Deduction for NetPlot Area | | | |
| Surrender Free of Cost | | | 35.02 |
| Total | | | 35.02 |
| NET AREA OF PLOT(Gross Plot Area - Deduction from Gross Plot area) | (A-Deductions) | | 235.11 |
| Deduction for Balance Plot Area(from Gross Plot Area) | | | |
| Surrender Free of Cost | | | 35.02 |
| Common Plot | | | 17.17 |
| Total | | | 52.19 |
| BALANCE AREA OF PLOT(Net Plot Area - Recreational/Amenity space) | (A-Deductions) | | 217.94 |
| PLOT AREA FOR COVERAGE(Net Plot Area) | (A-Deductions) | | 235.11 |
| Plot Area for FAR (Net Plot Area + RoadWidening Area) | (A-Deductions) | | 270.13 |

| | |
|---------------------------------------|--------|
| Permissible Coverage area (60.00 %) | 141.07 |
| Proposed Coverage Area (25.26 %) | 59.40 |
| Total Prop. Coverage Area (25.26 %) | 59.40 |
| Balance coverage area (34.74 %) | 81.67 |

| | |
|--------------------------|--------|
| FAR CHECK | |
| Perm. FAR Area (1.500) | 405.20 |
| Total Perm. FAR area | 405.20 |
| Residential FAR | 59.40 |
| Proposed FAR Area | 59.40 |
| Total Proposed FAR Area | 59.40 |
| Consumed FAR (Factor) | 0.22 |
| Balance FAR Area | 345.80 |

| | |
|-----------------------------|----------------|
| BUILT UP AREA CHECK | |
| Total Proposed BuiltUp Area | 59.40 |
| ARCHITECT (Regd) | MAHENDRA MEHTA |
| ENGINEER (Regd) | |
| SUPERVISOR (Regd) | |
| OWNER (Regd) | SUHATI KULLU |
| DEVELOPMENT AUTHORITY | LOCAL BODY |

SITE PLAN

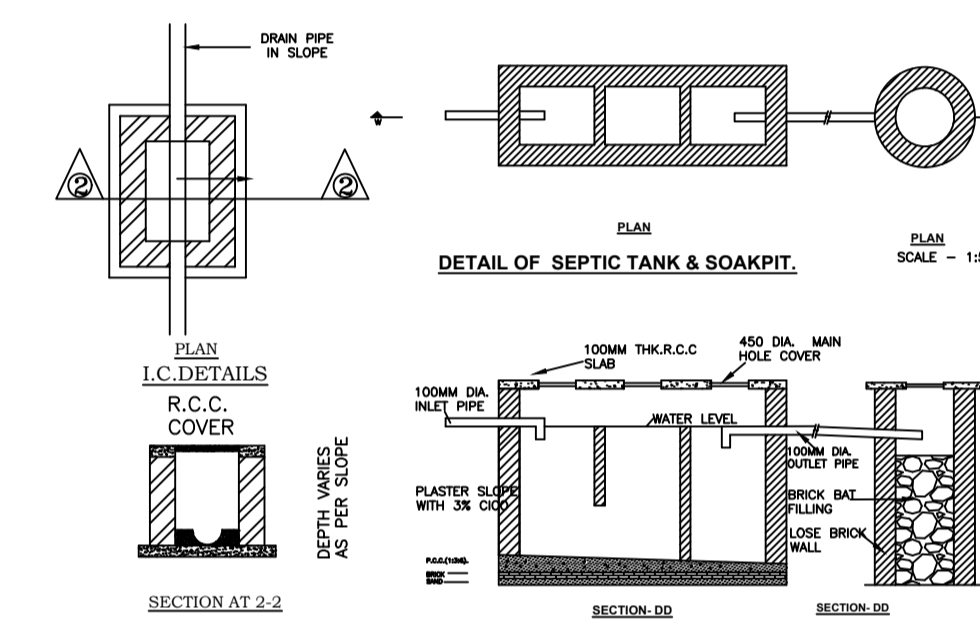
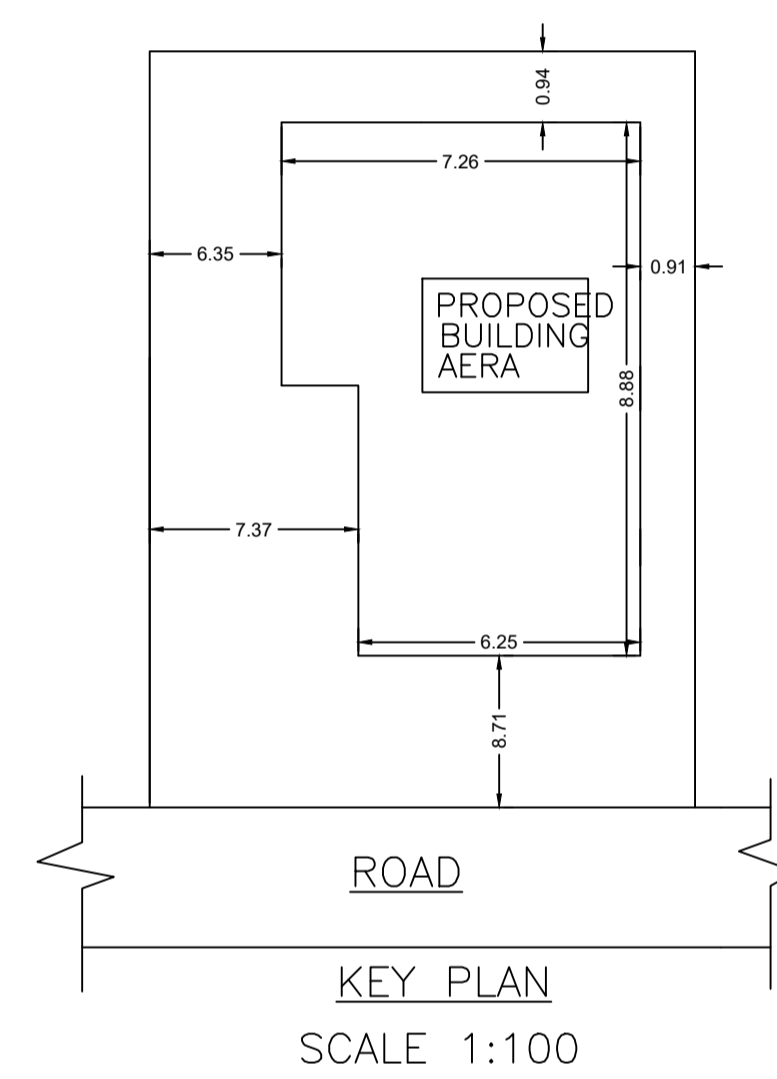
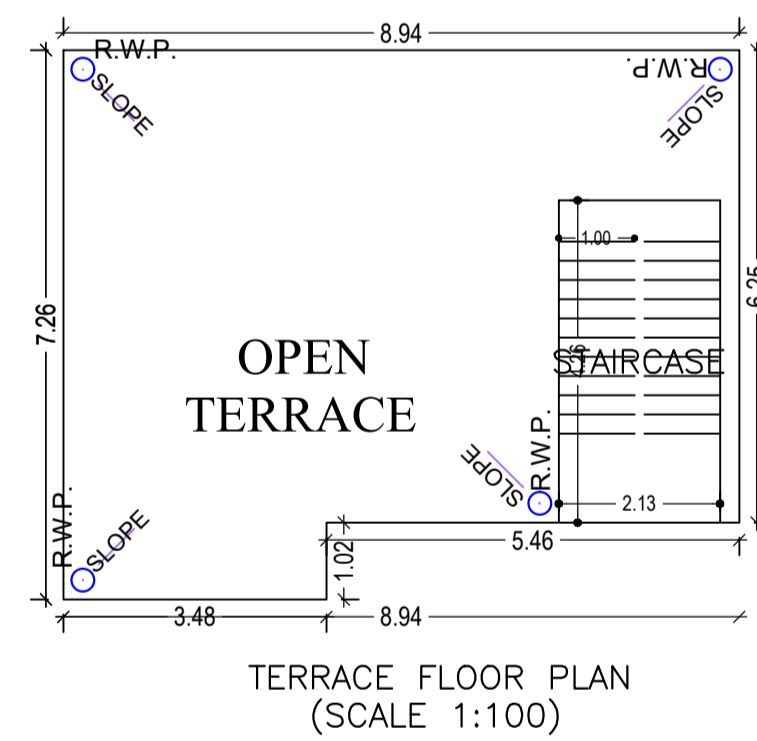
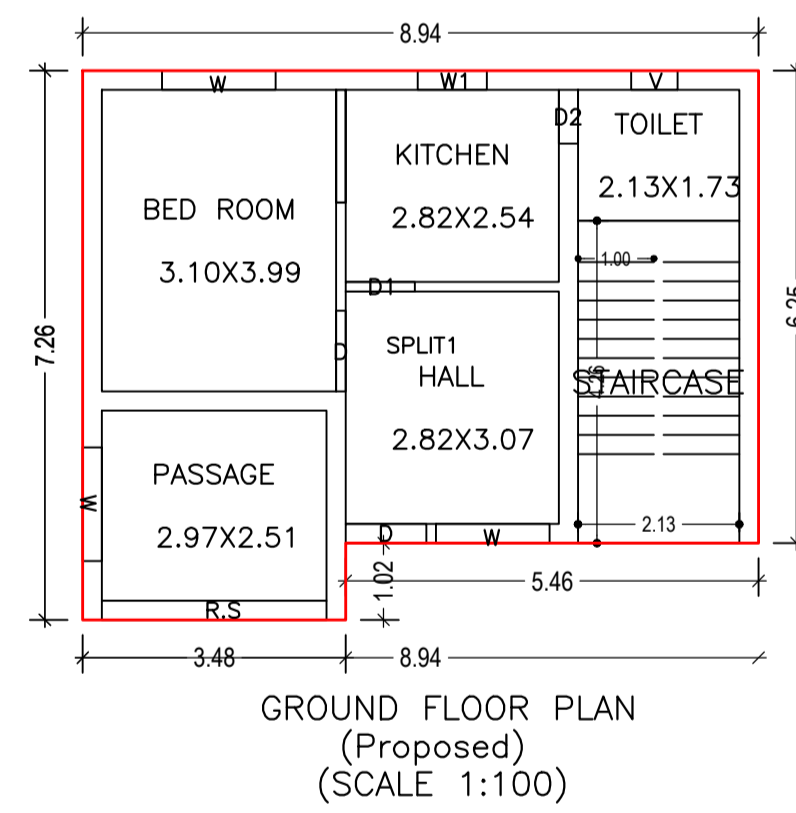

COLOR INDEX

| | |
|-----------------------------|------------|
| PLOT BOUNDARY | Black |
| ABUTTING ROAD | Green |
| PROPOSED CONSTRUCTION | Red |
| COMMON PLOT | Yellow |
| ROAD WIDENING AREA | Blue |
| EXISTING (To be retained) | Light Blue |
| EXISTING (To be demolished) | Orange |

Buildingwise Floor FAR Details

| Floor Name | Building Name A1 (RESIDENCE) | | Total | |
|---------------|---------------------------------|----------------------------|---------------------------------------|-------------------------|
| | Proposed Built Up Area (Sq.mt.) | Proposed FAR Area (Sq.mt.) | Total Proposed Built Up Area (Sq.mt.) | Total FAR Area (Sq.mt.) |
| Ground Floor | 59.40 | 59.40 | 59.40 | 59.40 |
| Terrace Floor | 0.00 | 0.00 | 0.00 | 0.00 |
| Total : | 59.40 | 59.40 | 59.40 | 59.40 |

Building USE/SUBUSE Details

| Building Name | Building Use | Building SubUse | Building Structure |
|----------------|--------------|------------------------------------|--------------------|
| A1 (RESIDENCE) | Residential | Bungalow/ Dwelling / Non Apartment | Non-Highrise |

Building :A1 (RESIDENCE)

| Floor Name | Total Built Up Area (Sq.mt.) | Proposed FAR Area (Sq.mt.) Resi. | Total FAR Area (Sq.mt.) | Total Consumed Additional FAR Area (Sq.mt.) | Tnmt (No.) |
|--------------------------------|------------------------------|----------------------------------|-------------------------|---|------------|
| Ground Floor | 59.40 | 59.40 | 59.40 | 59.40 | 01 |
| Terrace Floor | 0.00 | 0.00 | 0.00 | 0.00 | 00 |
| Total : | 59.40 | 59.40 | 59.40 | 59.40 | 01 |
| Total Number of Same Buildings | 1 | | | | |
| Total : | 59.40 | 59.40 | 59.40 | 59.40 | 01 |

SCHEDULE OF DOOR:

| BUILDING NAME | NAME | LENGTH | HEIGHT | NOS |
|----------------|------|--------|--------|-----|
| A1 (RESIDENCE) | D2 | 0.71 | 2.10 | 01 |
| A1 (RESIDENCE) | D1 | 0.91 | 2.10 | 01 |
| A1 (RESIDENCE) | D | 1.07 | 2.10 | 02 |
| A1 (RESIDENCE) | R.S | 2.97 | 2.10 | 01 |

SCHEDULE OF WINDOW/VENTILATION:

| BUILDING NAME | NAME | LENGTH | HEIGHT | NOS |
|----------------|------|--------|--------|-----|
| A1 (RESIDENCE) | V | 0.61 | 1.20 | 01 |
| A1 (RESIDENCE) | W1 | 0.92 | 1.20 | 01 |
| A1 (RESIDENCE) | W | 1.50 | 1.20 | 03 |

UnitBUA Table for Building :A1 (RESIDENCE)

| FLOOR | Name | UnitBUA Type | UnitBUA Area | Carpet Area | No. of Rooms | No. of Tenement |
|-------------------|--------|--------------|--------------|-------------|--------------|-----------------|
| GROUND FLOOR PLAN | SPLIT1 | FLAT | 42.87 | 42.69 | 5 | 1 |
| Total: | - | - | 42.87 | 42.69 | 5 | 1 |

