

SITE PLAN

FAR & Tenement Details (Table 4c-1)

Building	No. of Same Bldg	Total Built Up Area (Sq.mt.)	Proposed FAR Area (Sq.mt.) Resi.	Total FAR Area (Sq.mt.)	Total Consumed Additional FAR Area (Sq.mt.)	Tnmt (No.)
A1 (RESIDENCE)	1	141.03	141.03	141.03	141.03	01
Grand Total	1	141.03	141.03	141.03	141.03	01

Proposal Basic Information

Proposal File No.	SINPC/BP/0356/W14/2022
Owner Name	FULARI TIRKEY
Khata No	06
Plot No	710
Village Name	Saldega
Use	Residential
SubUse	Bungalow/ Dwelling / Non Apartment

AREA STATEMENT SIMDEGA NAGAR PANCHAYAT		VERSION NO. : 1.0.65
PROJECT DETAIL:		VERSION DATE: 16/10/2020
Region: JHARKHAND URBAN LOCAL BODIES	Plot Use: Residential	
District: SIMDEGA	Plot SubUse: Bungalow/ Dwelling / Non Apartment	
Authority: SIMDEGA NAGAR PANCHAYAT	PlotNearbyReligiousStructure: NA	
Inward No: SINPC/BP/0356/W14/2022	PlotSubPlot No: 710	
Application Type: General Proposal	North: -	
Project Type: Building Permission	South: -	
Nature of Development: New	East: -	
Location of Development Area: Old Area	West: -	
AREA DETAILS:		
AREA OF PLOT (Minimum)	(A)	SQ.MT. 311.38
Deduction for NetPlot Area		
Surrender Free of Cost		34.73
Total		34.73
NET AREA OF PLOT(Gross Plot Area - Deduction from Gross Plot area)		
(A-Deductions)		276.65
Deduction for Balance Plot Area(from Gross Plot Area)		
Surrender Free of Cost		34.73
Common Plot		33.98
Total		68.71
BALANCE AREA OF PLOT(Net Plot Area - Recreational/Amenity space)	(A-Deductions)	242.67
PLOT AREA FOR COVERAGE(Net Plot Area)	(A-Deductions)	276.65
Plot Area for FAR (Net Plot Area + RoadWidening Area)	(A-Deductions)	311.38
COVERAGE CHECK		
Permissible Coverage area (60.00 %)		165.99
Proposed Coverage Area (50.98 %)		141.03
Total Prop. Coverage Area (50.98 %)		141.03
Balance coverage area (9.02 %)		24.96
FAR CHECK		
Perm. FAR Area (1.500)		467.07
Total Perm. FAR area		467.07
Residential FAR		141.03
Proposed FAR Area		141.03
Total Proposed FAR Area		141.03
Consumed FAR (Factor)		0.45
Balance FAR Area		326.04
BUILT UP AREA CHECK		
Total Proposed BuiltUp Area		141.03
ARCHITECT (Regd)	MAHENDRA MEHTA	
ENGINEER (Regd)		
SUPERVISOR (Regd)		
OWNER (Regd)	FULARI TIRKEY	
DEVELOPMENT AUTHORITY		LOCAL BODY

COLOR INDEX	
PLOT BOUNDARY	Black
ABUTTING ROAD	Green
PROPOSED CONSTRUCTION	Red
COMMON PLOT	Yellow
ROAD WIDENING AREA	Orange
EXISTING (To be retained)	Blue
EXISTING (To be demolished)	Light Blue

Buildingwise Floor FAR Details

Floor Name	Building Name A1 (RESIDENCE)		Total	
	Proposed Built Up Area (Sq.mt.)	Proposed FAR Area (Sq.mt.)	Total Proposed Built Up Area (Sq.mt.)	Total FAR Area (Sq.mt.)
Ground Floor	141.03	141.03	141.03	141.03
Terrace Floor	0.00	0.00	0.00	0.00
Total	141.03	141.03	141.03	141.03

Building USE/SUBUSE Details

Building Name	Building Use	Building SubUse	Building Structure
A1 (RESIDENCE)	Residential	Bungalow/ Dwelling / Non Apartment	Non-Highrise

LTP NAME AND SIGNATURE	STRUCTURAL ENG'S NAME AND SIGNATURE	BUILDER NAME AND SIGNATURE	DIGITAL SIGNATURE
MAHENDRA MEHTA SINPC/DFTMN/0002/2022			

Proposal Basic Information	
Proposal File No.	SINPC/BP/0356/W14/2022
Owner Name	FULARI TIRKEY
Khata No	06
Plot No	710
Village Name	Saldega
Use	Residential
SubUse	Bungalow/ Dwelling / Non Apartment

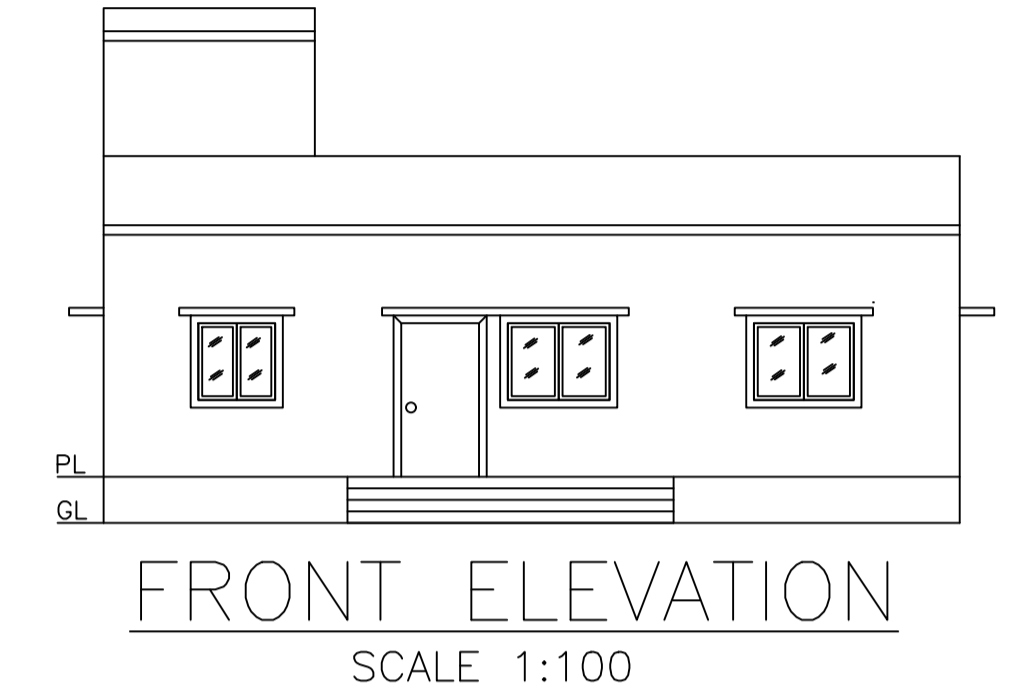
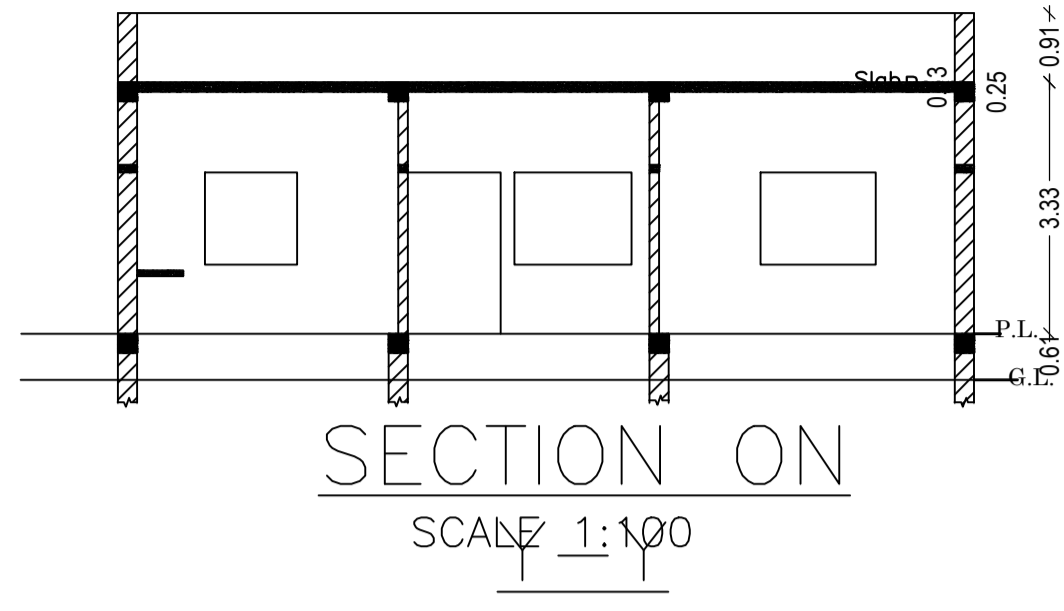
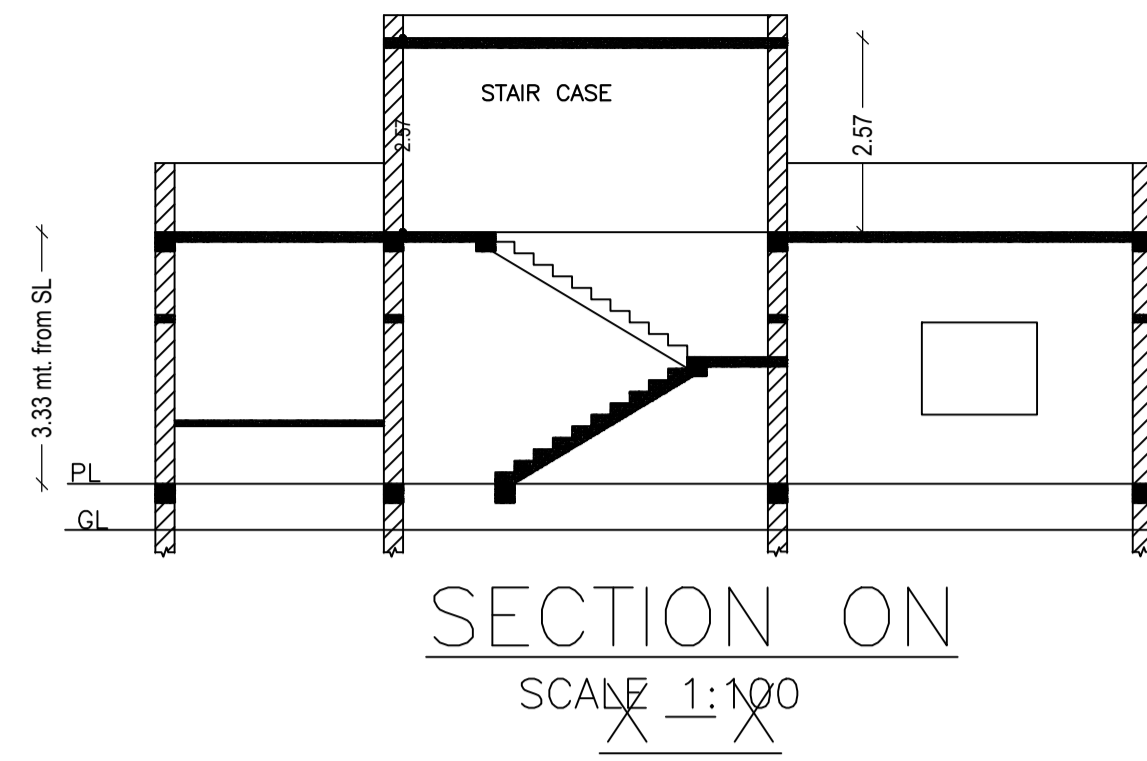
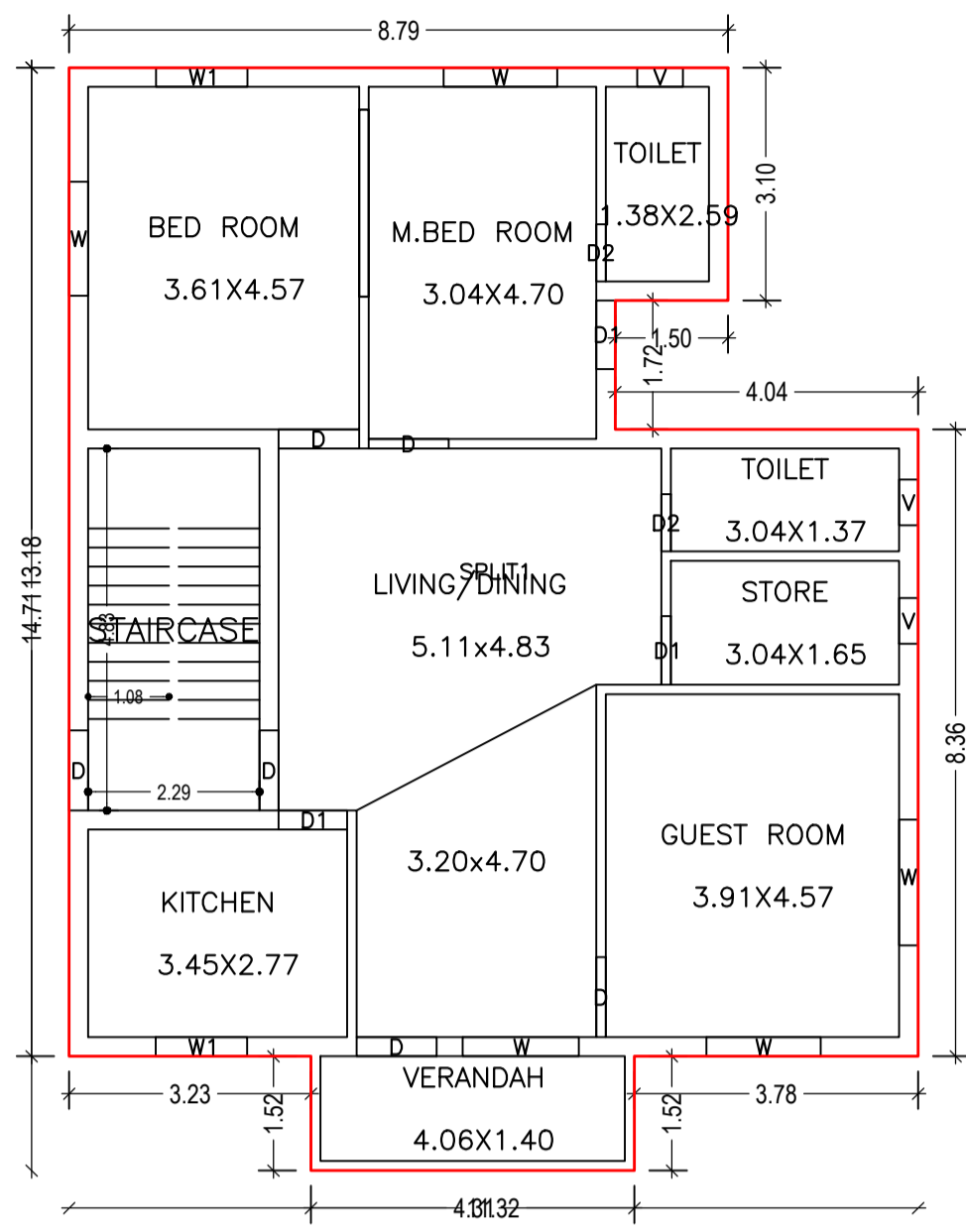

GROUND FLOOR PLAN (Proposed) (SCALE 1:100)

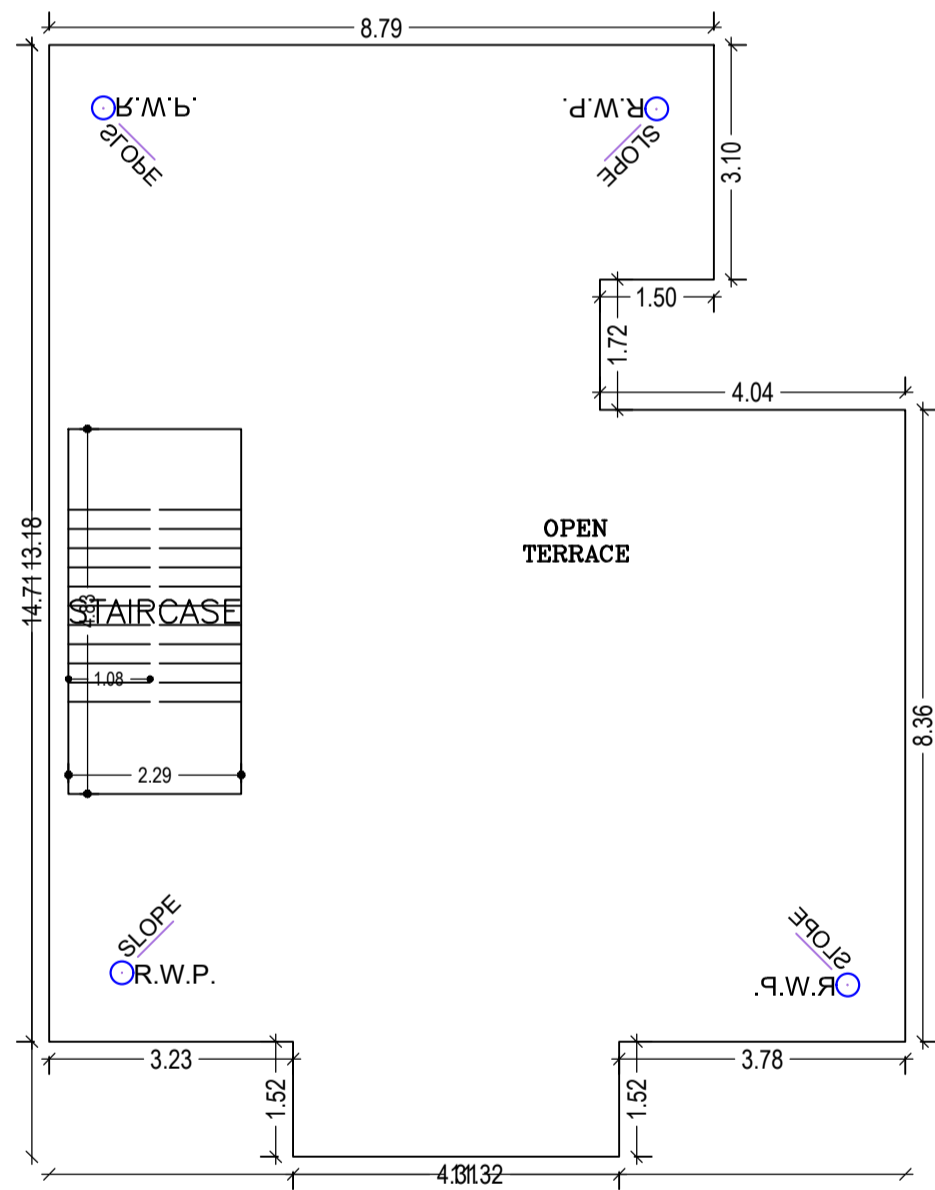

TERRACE FLOOR PLAN (SCALE 1:100)

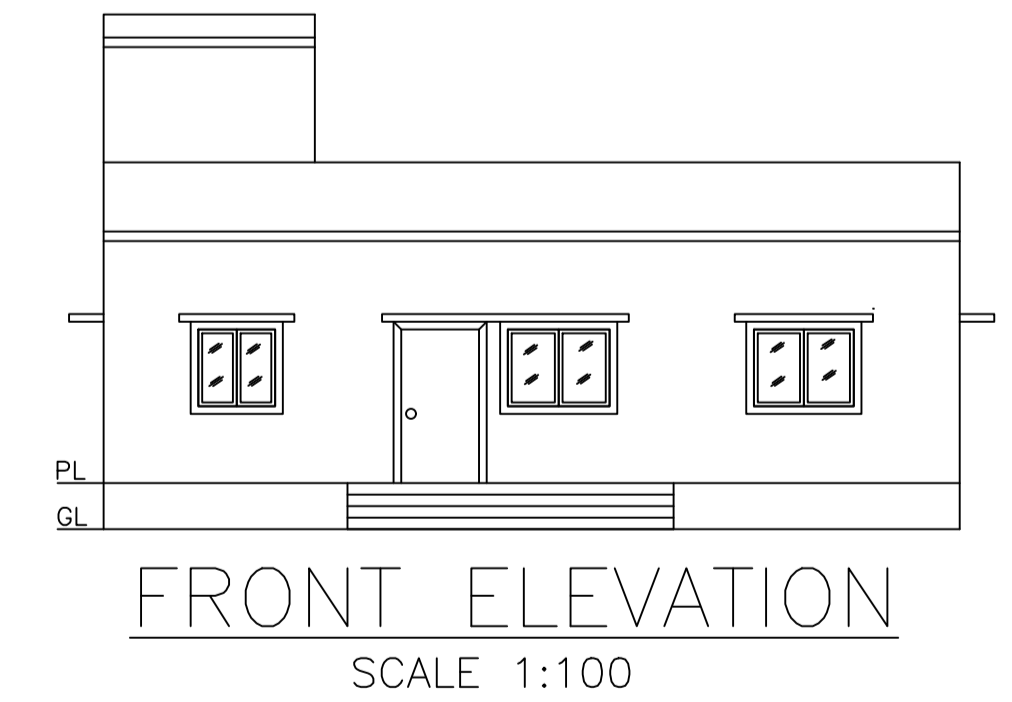
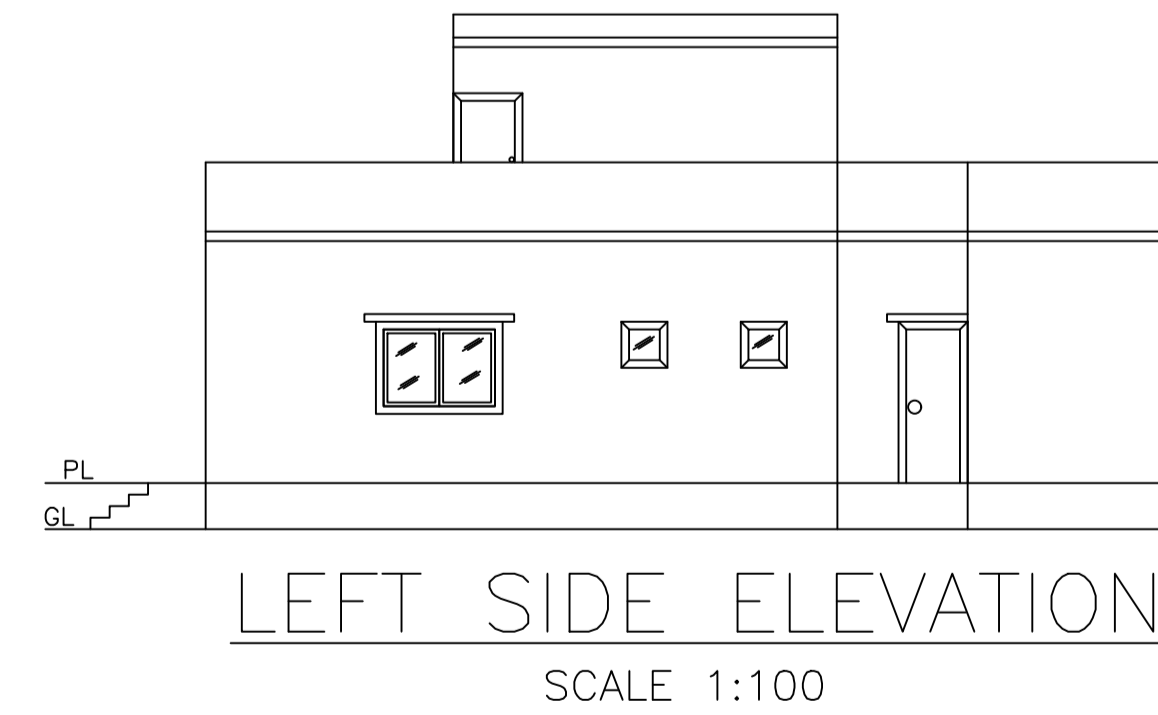
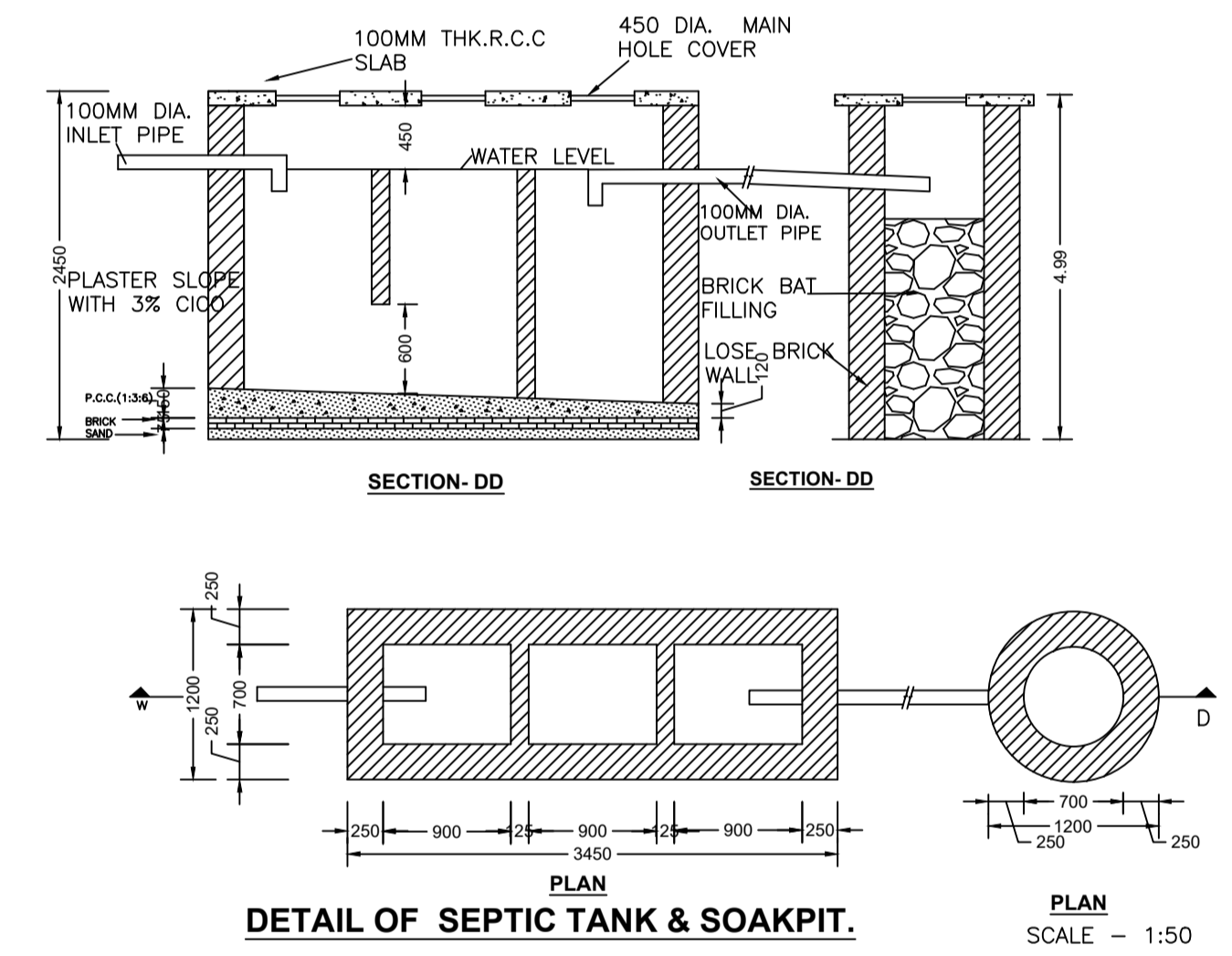
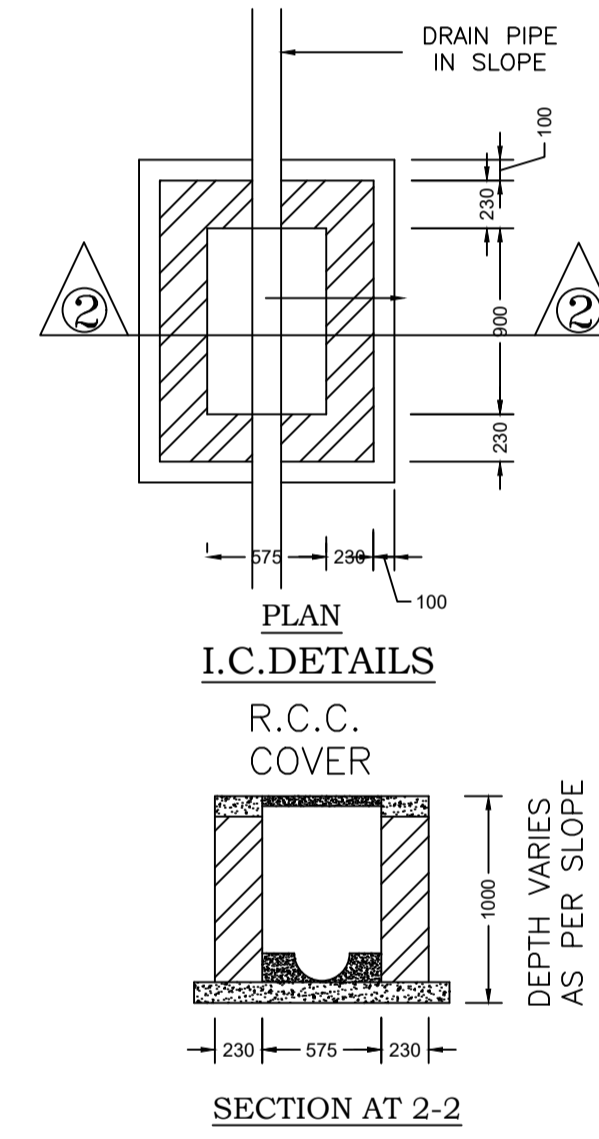
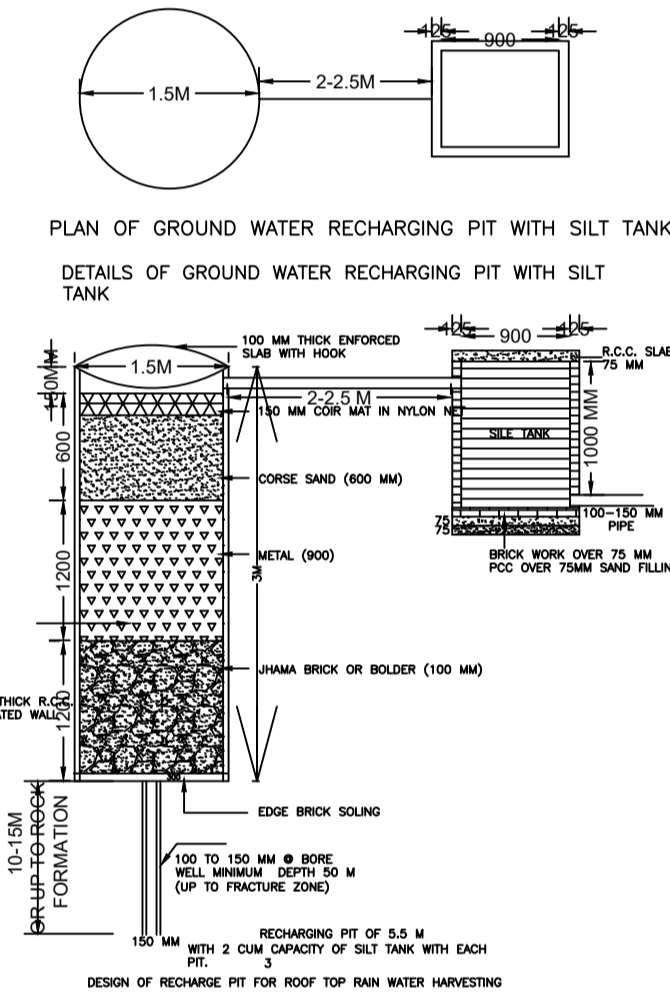
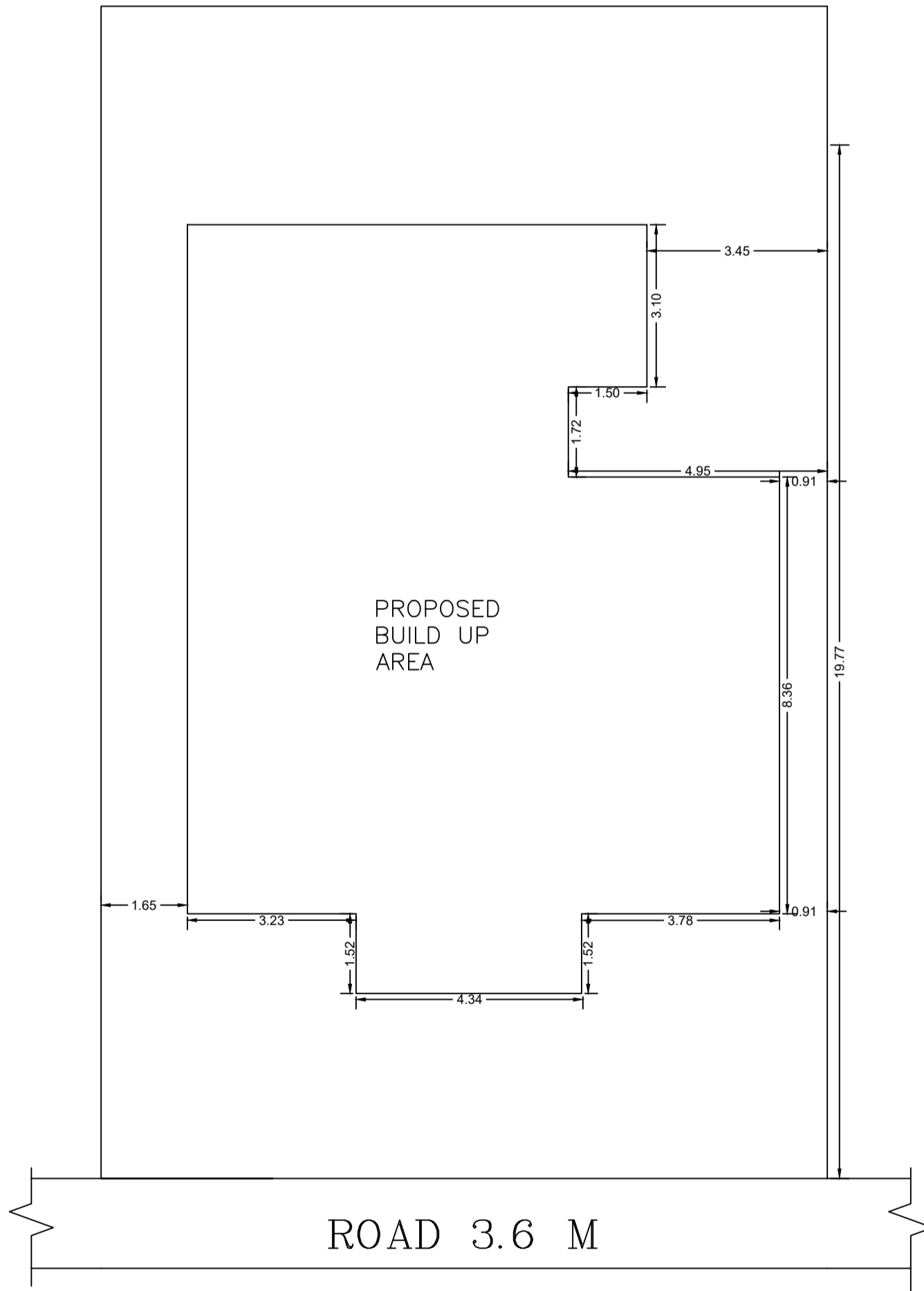

SCHEDULE OF DOOR:

BUILDING NAME	NAME	LENGTH	HEIGHT	NOS
A1 (RESIDENCE)	D2	0.76	2.10	02
A1 (RESIDENCE)	D1	0.91	2.10	03
A1 (RESIDENCE)	D	1.07	2.10	05

SCHEDULE OF WINDOW/VENTILATION:

BUILDING NAME	NAME	LENGTH	HEIGHT	NOS
A1 (RESIDENCE)	V	0.61	1.20	03
A1 (RESIDENCE)	W1	1.22	1.20	02
A1 (RESIDENCE)	W	1.52	1.20	03
A1 (RESIDENCE)	W	1.55	1.20	01
A1 (RESIDENCE)	W	1.68	1.20	01

Building :A1 (RESIDENCE)

Floor Name	Total Built Up Area (Sq.mt.)	Proposed FAR Area (Sq.mt.)	Total FAR Area (Sq.mt.)	Total Consumed Additional FAR Area (Sq.mt.)	Tnmt (No.)
Ground Floor	141.03	141.03	141.03	141.03	01
Terrace Floor	0.00	0.00	0.00	0.00	00
Total :	141.03	141.03	141.03	141.03	01
Total Number of Same Buildings	1				
Total :	141.03	141.03	141.03	141.03	01

UnitBUA Table for Building :A1 (RESIDENCE)

FLOOR	Name	UnitBUA Type	UnitBUA Area	Carpet Area	No. of Rooms	No. of Tenement
GROUND FLOOR PLAN	SPLIT1	FLAT	128.20	127.89	9	1
Total:	-	-	128.20	127.89	9	1

LTP NAME AND SIGNATURE	STRUCTURAL ENG'S NAME AND SIGNATURE	BUILDER NAME AND SIGNATURE	DIGITAL SIGNATURE
MAHENDRA MEHTA SINPC/DFTMN/0002/2022			

Proposal Basic Information

Proposal File No.	SINPC/BP/0356/W14/2022
Owner Name	FULARI TIRKEY
Khata No	06
Plot No	710
Village Name	Saldega
Use	Residential
SubUse	Bungalow/ Dwelling / Non Apartment

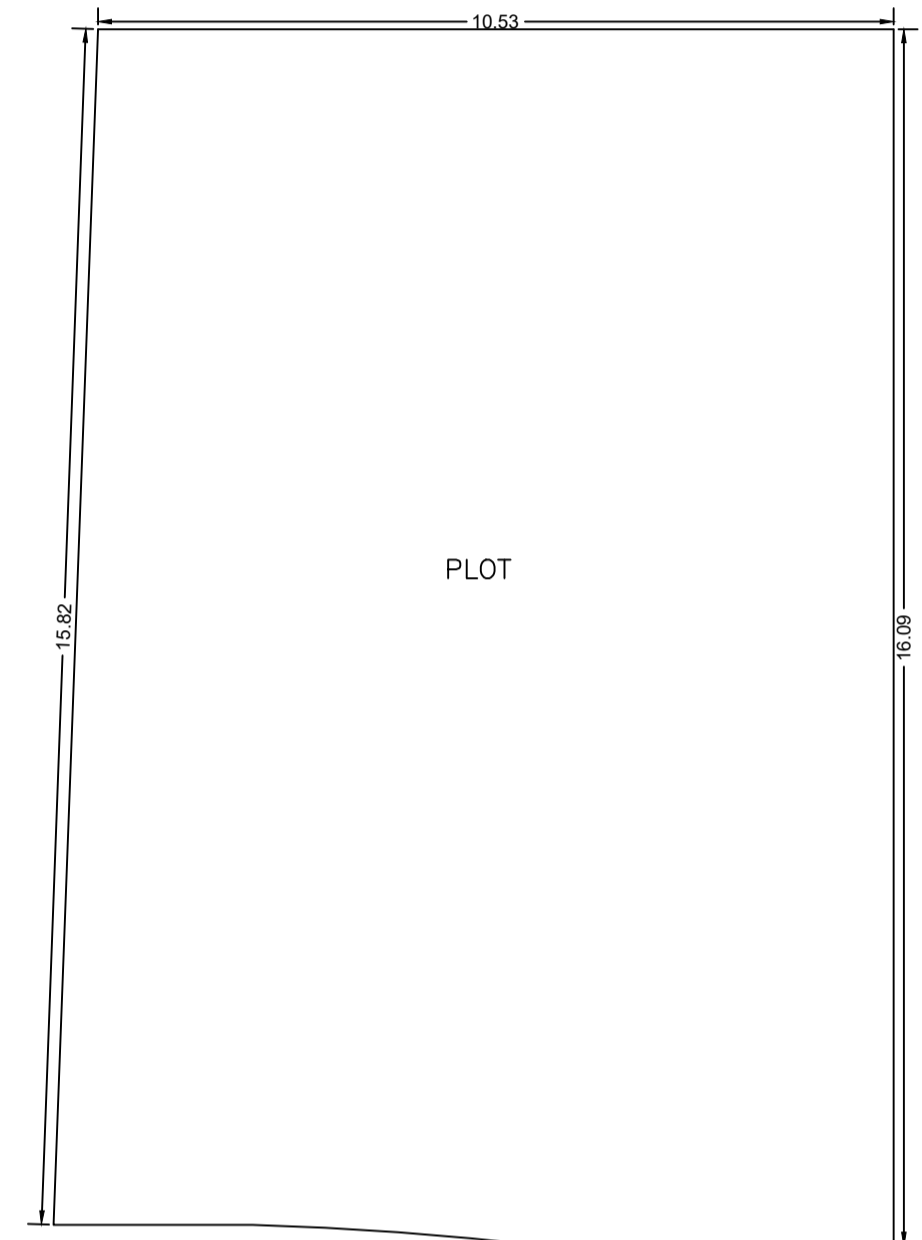

SALDEGA DIPA TOLI P.C.C 12' KUNJ NAGAR

LOCATION PLAN
NOT IN SCALE

LTP NAME AND SIGNATURE	STRUCTURAL ENG'S NAME AND SIGNATURE	BUILDER NAME AND SIGNATURE	DIGITAL SIGNATURE
MAHENDRA MEHTA SINPC/DFTMN/0002/2022			