

SITE PLAN

FAR & Tenement Details (Table 4c-1)

Building	No. of Same Bldg	Total Built Up Area (Sq.mt.)	Deductions (Area in Sq.mt.)	Proposed FAR Area (Sq.mt.)	Total FAR Area (Sq.mt.)	Total Consumed Additional FAR Area (Sq.mt.)	Tnmt (No.)
A1 (RESIDENTIAL)	1	244.93	17.90	227.03	227.03	227.03	01
Grand Total :	1	244.93	17.90	227.03	227.03	227.03	01

Proposal Basic Information

Proposal File No.	SINPC/BP/0437/W01/2023
Owner Name	VICTORIA XALXO
Khata No	154
Plot No	1394
Village Name	Gotra
Use	Residential
SubUse	Bungalow/ Dwelling / Non Apartment

AREA STATEMENT SIMDEGA NAGAR PANCHAYAT

VERSION NO: 1.0.66
VERSION DATE: 16/10/2020

PROJECT DETAIL:

Region: JHARKHAND URBAN LOCAL BODIES	Plot Use: Residential
District: SIMDEGA	Plot SubUse: Bungalow/ Dwelling / Non Apartment
Authority: SIMDEGA NAGAR PANCHAYAT	PlotNearbyReligiousStructure: NA
Inward No: SINPC/BP/0437/W01/2023	PlotSubPlot No: 1394
Application Type: General Proposal	North: -
Project Type: Building Permission	South: -
Nature of Development: New	East: -
Location of Development Area: Old Area	West: -

AREA DETAILS:

AREA OF PLOT (Minimum)	(A)	SQ.MT.
Deduction for NetPlot Area		665.11
Surrender Free of Cost		25.71
Total		25.71
NET AREA OF PLOT(Gross Plot Area - Deduction from Gross Plot area)	(A-Deductions)	639.40
Deduction for Balance Plot Area(from Gross Plot Area)		25.71
Surrender Free of Cost		25.71
Common Plot		46.13
Total		71.84
BALANCE AREA OF PLOT(Net Plot Area - Recreational/Amenity space)	(A-Deductions)	593.27
PLOT AREA FOR COVERAGE(Net Plot Area)	(A-Deductions)	639.40
Plot Area for FAR (Net Plot Area + RoadWidening Area)	(A-Deductions)	665.11

COVERAGE CHECK

Permissible Coverage area (60.00 %)	383.64
Proposed Coverage Area (19.14 %)	122.41
Total Prop. Coverage Area (19.14 %)	122.41
Balance coverage area (40.86 %)	261.23

FAR CHECK

Perm. FAR Area (1.500)	997.66
Total Perm. FAR area	997.66
Residential FAR	227.04
Proposed FAR Area	227.04
Total Proposed FAR Area	227.04
Consumed FAR (Factor)	0.34
Balance FAR Area	770.62

BUILT UP AREA CHECK

Total Proposed BuiltUp Area	244.93
-----------------------------	--------

ARCHITECT (Regd) MAHENDRA MEHTA
ENGINEER (Regd)
SUPERVISOR (Regd)
OWNER (Regd) VICTORIA XALXO
DEVELOPMENT AUTHORITY LOCAL BODY

COLOR INDEX

PLOT BOUNDARY	Black
ABUTTING ROAD	Green
PROPOSED CONSTRUCTION	Red
COMMON PLOT	Yellow
ROAD WIDENING AREA	Blue
EXISTING (To be retained)	Blue
EXISTING (To be demolished)	Yellow

Buildingwise Floor FAR Details

Floor Name	Building Name		Total	
	Proposed Built Up Area (Sq.mt.)	Proposed FAR Area (Sq.mt.)	Total Proposed Built Up Area (Sq.mt.)	Total FAR Area (Sq.mt.)
Ground Floor	122.41	104.51	122.41	104.51
First Floor	122.52	122.52	122.52	122.52
Terrace Floor	0.00	0.00	0.00	0.00
Total :	244.93	227.03	244.93	227.03

Building USE/SUBUSE Details

Building Name	Building Use	Building SubUse	Building Structure
A1 (RESIDENTIAL)	Residential	Bungalow/ Dwelling / Non Apartment	Non-Highrise

LTP NAME AND SIGNATURE	STRUCTURAL ENG'S NAME AND SIGNATURE	BUILDER NAME AND SIGNATURE	DIGITAL SIGNATURE
MAHENDRA MEHTA SINPC/DFTMN/0002/2022			

Proposal File No.	SINPC/BP/0437/W01/2023
Owner Name	VICTORIA XALXO
Khata No	154
Plot No	1394
Village Name	Gotra
Use	Residential
SubUse	Bungalow/ Dwelling / Non Apartment

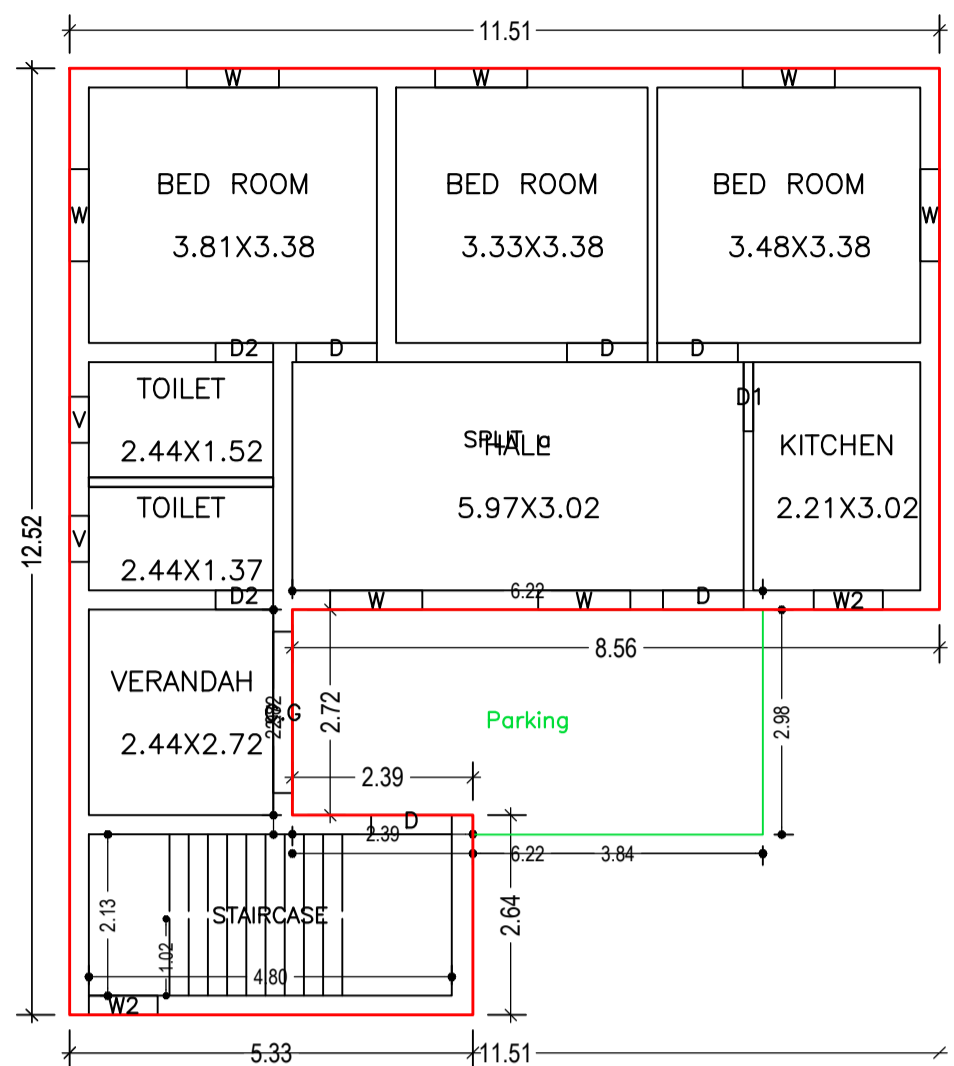

GROUND FLOOR PLAN (Proposed) (SCALE 1:100)

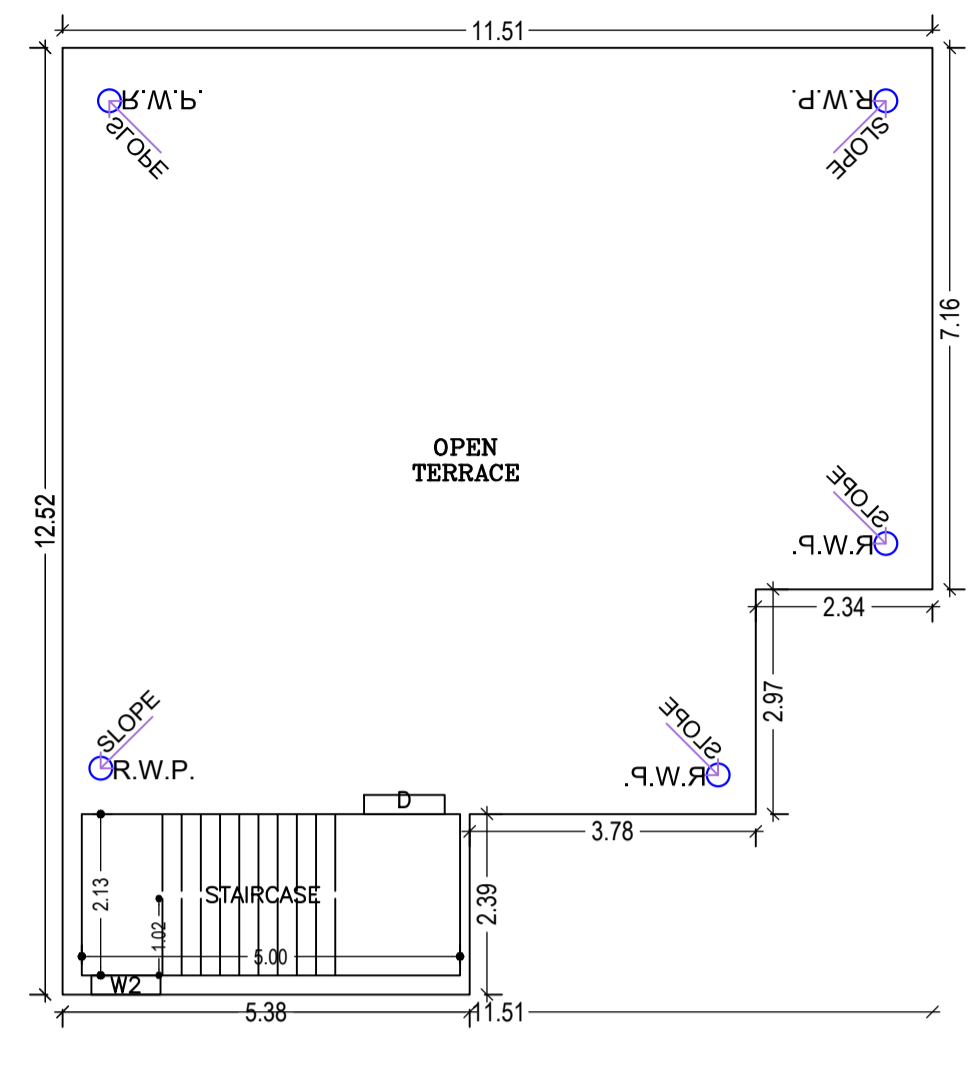

TERRACE FLOOR PLAN (SCALE 1:100)

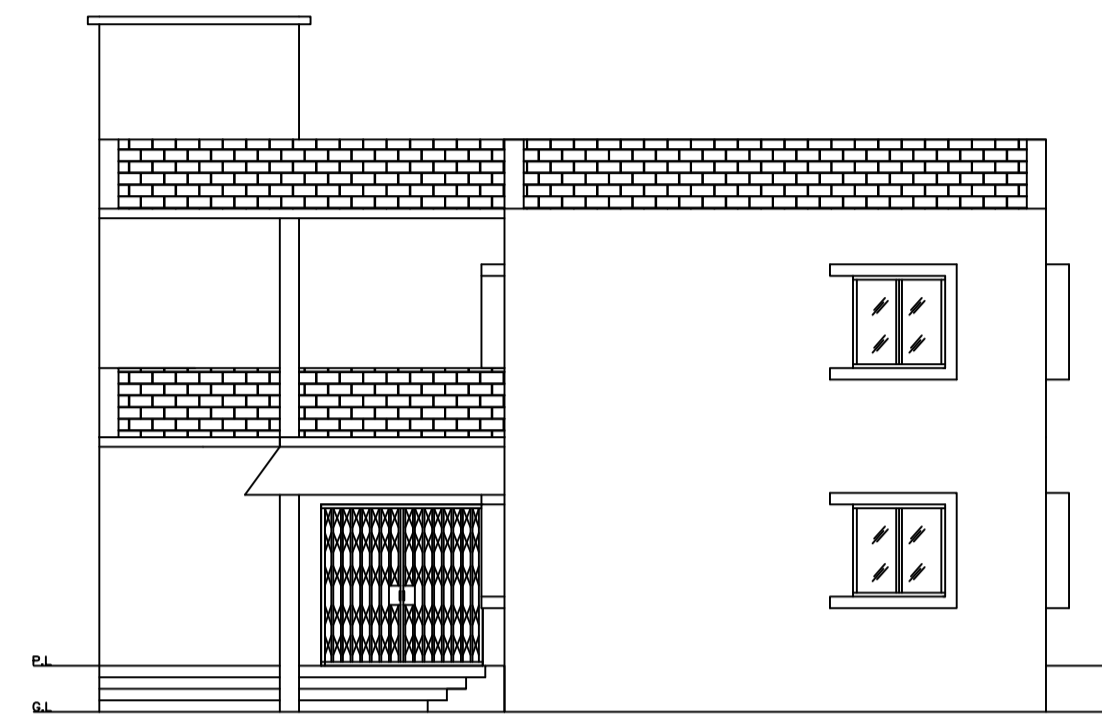

LEFT SIDE ELEVATION SCALE 1:100

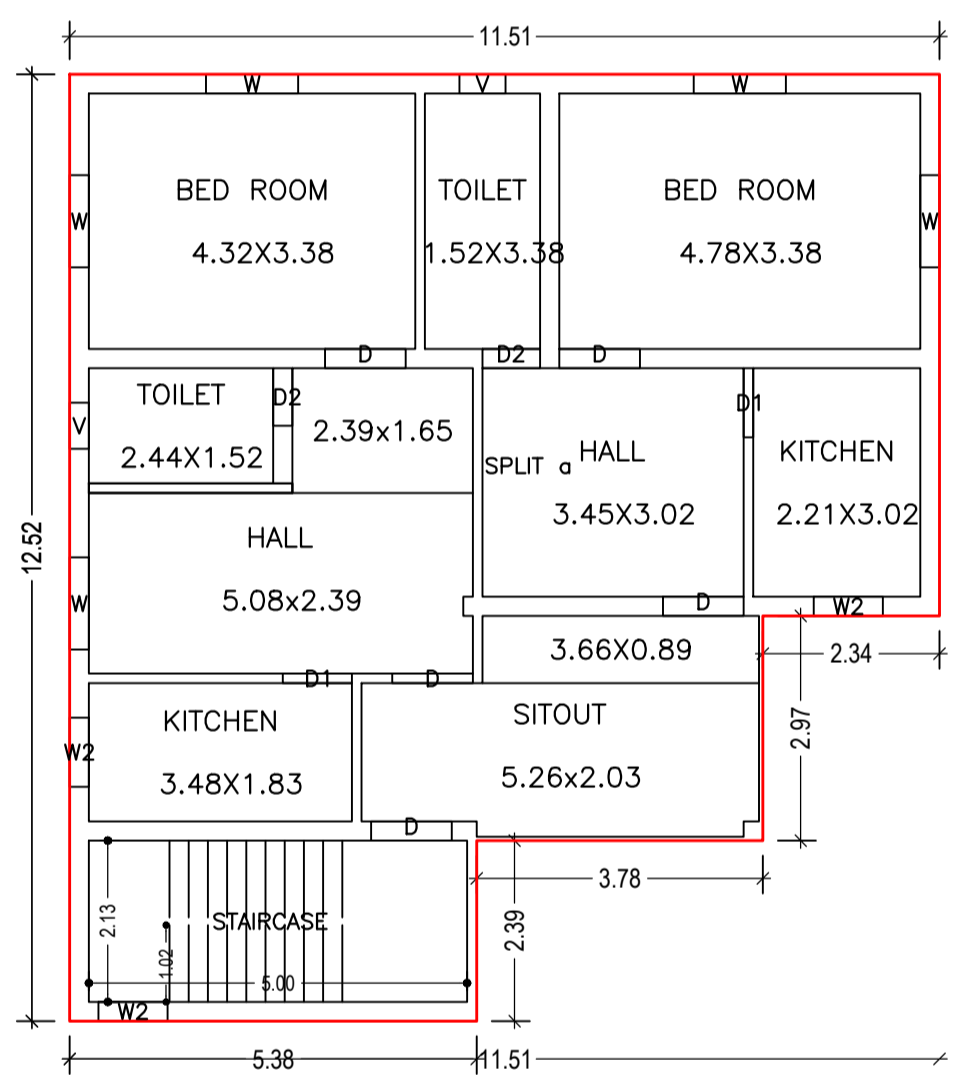

FIRST FLOOR PLAN (Proposed) (SCALE 1:100)

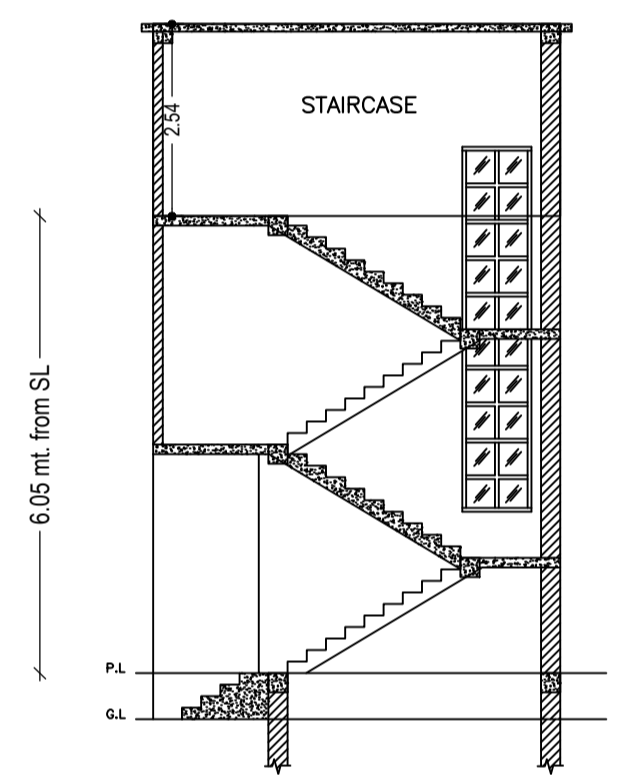

SECTION ON SCALE 1:100

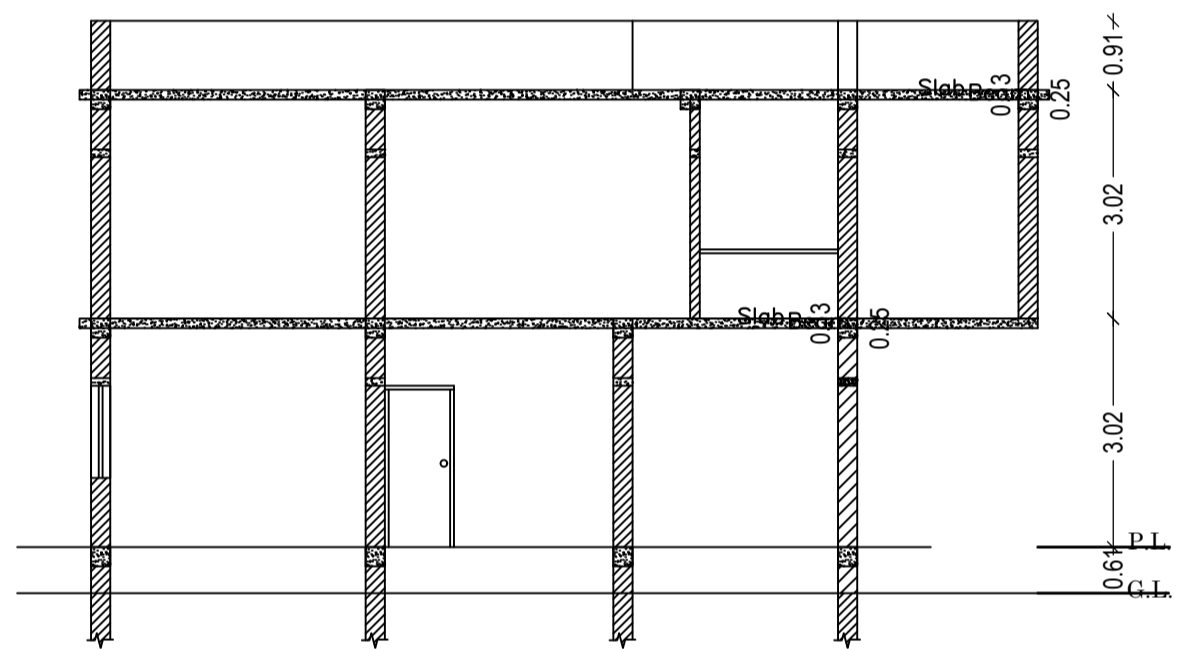

SECTION ON SCALE 1:100

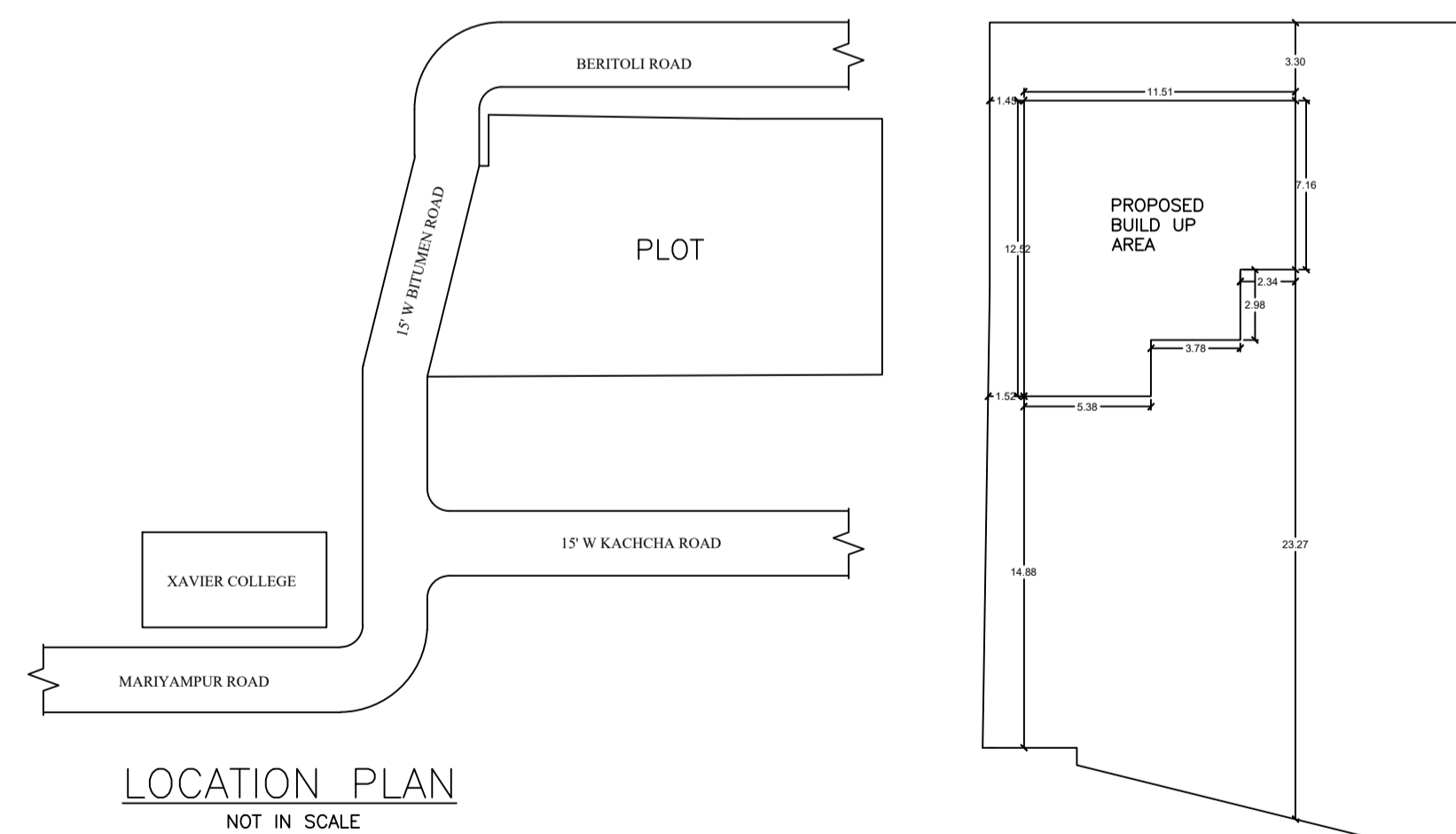

LOCATION PLAN NOT IN SCALE

KEY PLAN SCALE 1:200

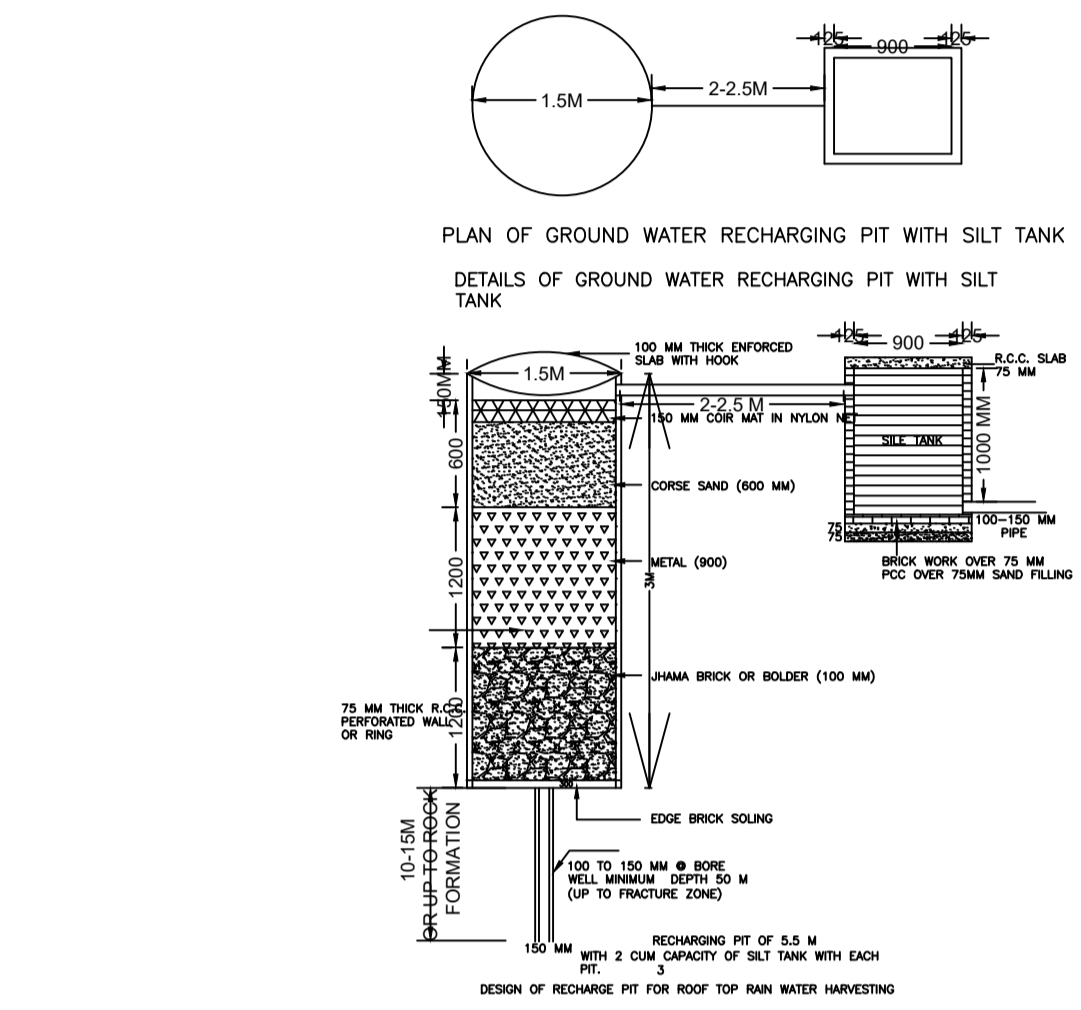

PLAN OF GROUND WATER RECHARGING PIT WITH SILT TANK
DETAILS OF GROUND WATER RECHARGING PIT WITH SILT TANK
DESIGN OF RECHARGE PIT FOR ROOF TOP RAIN WATER HARVESTING

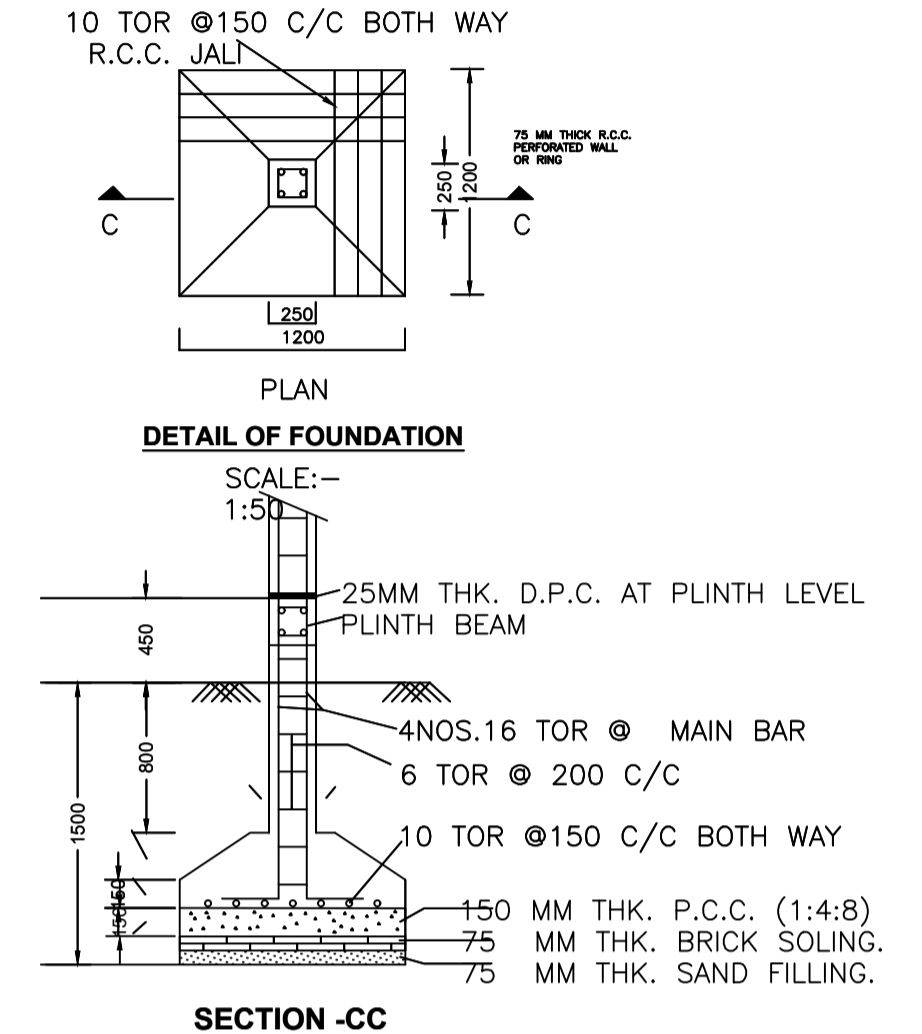

DETAIL OF FOUNDATION
SCALE:- 1:5
10 TOR @150 C/C BOTH WAY
R.C.C. JALI
25MM THK. D.P.C. AT PLINTH LEVEL
PLINTH BEAM
4NOS.16 TOR @ MAIN BAR
6 TOR @ 200 C/C
10 TOR @150 C/C BOTH WAY
150 MM THK. P.C.C. (1:4:8)
75 MM THK. BRICK SOLING.
75 MM THK. SAND FILLING.

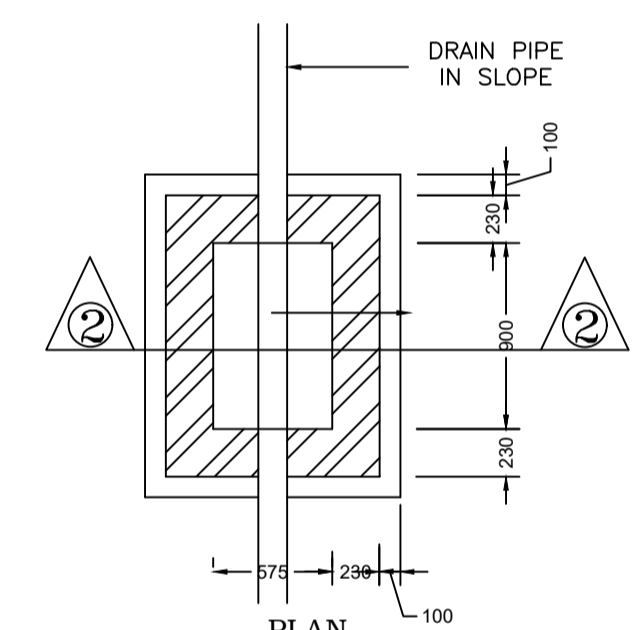

PLAN I.C.DETAILS

R.C.C. COVER

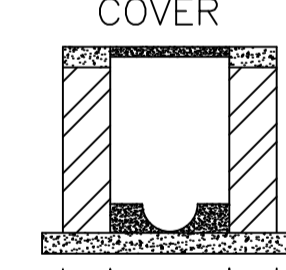

SECTION AT 2-2

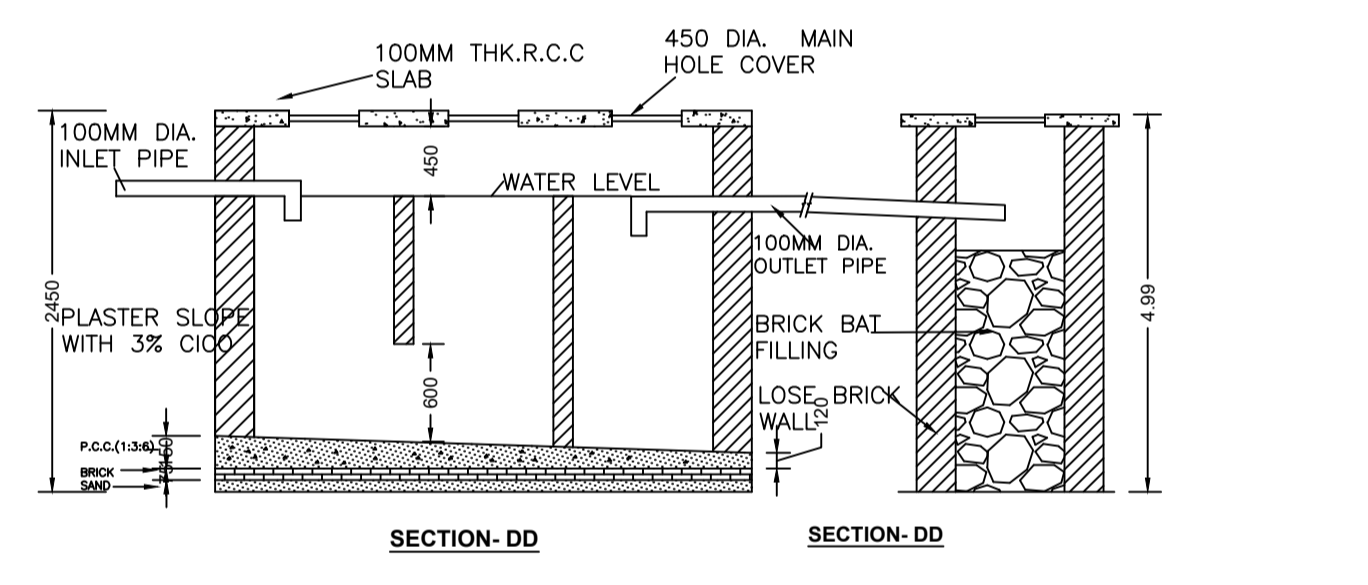

SECTION-DD

SECTION-DD

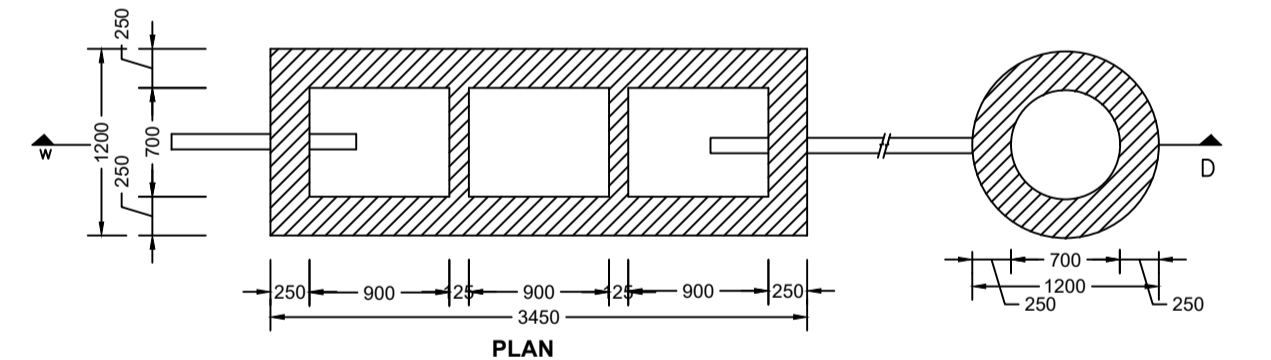

DETAIL OF SEPTIC TANK & SOAKPIT.

PLAN SCALE - 1:50

Building :A1 (RESIDENTIAL)

Floor Name	Total Built Up Area (Sq.mt.)	Deductions (Area in Sq.mt.)	Proposed FAR Area (Sq.mt.)	Total FAR Area (Sq.mt.)	Total Consumed Additional FAR Area (Sq.mt.)	Trmt (No.)
Ground Floor	122.41	17.90	104.51	104.51	104.51	01
First Floor	122.52	0.00	122.52	122.52	122.52	00
Terrace Floor	0.00	0.00	0.00	0.00	0.00	00
Total :	244.93	17.90	227.03	227.03	227.03	01
Total Number of Same Buildings	1					
Total :	244.93	17.90	227.03	227.03	227.03	01

SCHEDULE OF DOOR:

BUILDING NAME	NAME	LENGTH	HEIGHT	NOS
A1 (RESIDENTIAL)	D2	0.76	2.10	04
A1 (RESIDENTIAL)	D1	0.91	2.10	03
A1 (RESIDENTIAL)	D	1.07	2.10	09
A1 (RESIDENTIAL)	C.G	2.13	2.10	01

SCHEDULE OF WINDOW/VENTILATION:

BUILDING NAME	NAME	LENGTH	HEIGHT	NOS
A1 (RESIDENTIAL)	V	0.61	1.20	04
A1 (RESIDENTIAL)	W2	0.91	1.20	06
A1 (RESIDENTIAL)	W	1.22	1.20	12

UnitBUA Table for Building :A1 (RESIDENTIAL)

FLOOR	Name	UnitBUA Type	UnitBUA Area	Carpet Area	No. of Rooms	No. of Tenement
GROUND FLOOR PLAN	SPLIT a	FLAT	180.64	179.99	8	1
FIRST FLOOR PLAN	SPLIT a	FLAT	0.00	0.00	9	0
Total:	-	-	180.64	179.99	17	1

LTP NAME AND SIGNATURE	STRUCTURAL ENG'S NAME AND SIGNATURE	BUILDER NAME AND SIGNATURE	DIGITAL SIGNATURE
MAHENDRA MEHTA SINPC/DFTMN/002/2022			

Proposal Basic Information	
Proposal File No.	SINPC/BP/0437/W01/2023
Owner Name	VICTORIA XALXO
Khata No	154
Plot No	1394
Village Name	Gotra
Use	Residential
SubUse	Bungalow/ Dwelling / Non Apartment

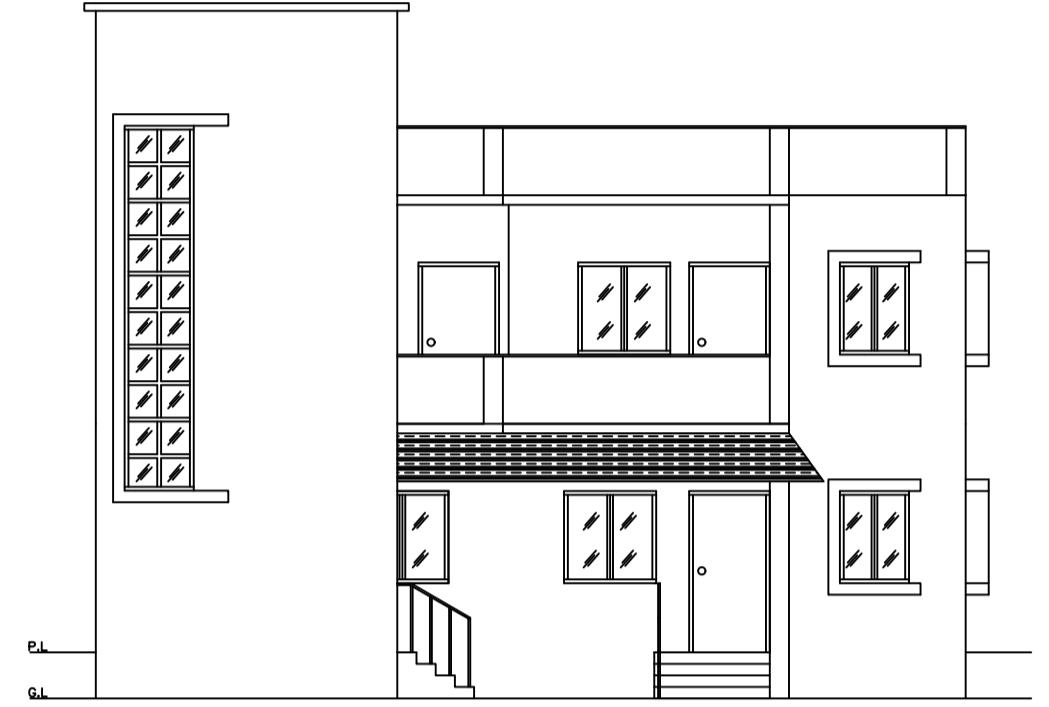

FRONT ELEVATION
SCALE 1:100

LTP NAME AND SIGNATURE	STRUCTURAL ENG'S NAME AND SIGNATURE	BUILDER NAME AND SIGNATURE	DIGITAL SIGNATURE
MAHENDRA MEHTA SINPC/DFTMN/0002/2022			