

SITE PLAN

FAR & Tenement Details (Table 4c-1)

Building	No. of Same Bldg	Total Built Up Area (Sq.mt.)	Proposed FAR Area (Sq.mt.) Resi.	Total FAR Area (Sq.mt.)	Total Consumed Additional FAR Area (Sq.mt.)	Tnmt (No.)
A1 (RESIDENTIAL)	1	95.42	95.42	95.42	95.42	01
Grand Total :	1	95.42	95.42	95.42	95.42	01

Proposal Basic Information

Proposal File No.	SINPC/BP/0436/W15/2023
Owner Name	JABLEN SAMAD
Khata No	45
Plot No	2073
Village Name	Simdega
Use	Residential
SubUse	Bungalow/ Dwelling / Non Apartment

AREA STATEMENT SIMDEGA NAGAR PANCHAYAT		VERSION NO. : 1.0.66	
PROJECT DETAIL:		VERSION DATE: 16/10/2020	
Region: JHARKHAND URBAN LOCAL BODIES	Plot Use: Residential		
District: SIMDEGA	Plot SubUse: Bungalow/ Dwelling / Non Apartment		
Authority: SIMDEGA NAGAR PANCHAYAT	PlotNearbyReligiousStructure: NA		
Inward No: SINPC/BP/0436/W15/2023	PlotSubPlot No: 2073		
Application Type: General Proposal	North: -		
Project Type: Building Permission	South: -		
Nature of Development: New	East: -		
Location of Development Area: Old Area	West: -		
AREA DETAILS:			SQ.MT.
AREA OF PLOT (Minimum)	(A)		404.64
Deduction for NetPlot Area			
Surrender Free of Cost			13.36
Total			13.36
NET AREA OF PLOT(Gross Plot Area - Deduction from Gross Plot area)	(A-Deductions)		391.28
Deduction for Balance Plot Area(from Gross Plot Area)			
Surrender Free of Cost			13.36
Common Plot			24.42
Total			37.78
BALANCE AREA OF PLOT(Net Plot Area - Recreational/Amenity space)	(A-Deductions)		366.86
PLOT AREA FOR COVERAGE(Net Plot Area)	(A-Deductions)		391.28
Plot Area for FAR (Net Plot Area + RoadWidening Area)	(A-Deductions)		404.64
COVERAGE CHECK			
Permissible Coverage area (60.00 %)			234.77
Proposed Coverage Area (24.39 %)			95.42
Total Prop. Coverage Area (24.39 %)			95.42
Balance coverage area (35.61 %)			139.35
FAR CHECK			
Perm. FAR Area (1.500)			606.96
Total Perm. FAR area			606.96
Residential FAR			95.42
Proposed FAR Area			95.42
Total Proposed FAR Area			95.42
Consumed FAR (Factor)			0.24
Balance FAR Area			511.54
BUILT UP AREA CHECK			
Total Proposed BuiltUp Area			95.42
ARCHITECT (Regd)		MAHENDRA MEHTA	
ENGINEER (Regd)			
SUPERVISOR (Regd)			
OWNER (Regd)		JABLEN SAMAD	
DEVELOPMENT AUTHORITY		LOCAL BODY	

COLOR INDEX	
PLOT BOUNDARY	Black
ABUTTING ROAD	Green
PROPOSED CONSTRUCTION	Red
COMMON PLOT	Yellow
ROAD WIDENING AREA	Orange
EXISTING (To be retained)	Blue
EXISTING (To be demolished)	Light Blue

Buildingwise Floor FAR Details

Floor Name	Building Name A1 (RESIDENTIAL)		Total	
	Proposed Built Up Area (Sq.mt.)	Proposed FAR Area (Sq.mt.)	Total Proposed Built Up Area (Sq.mt.)	Total FAR Area (Sq.mt.)
Ground Floor	95.42	95.42	95.42	95.42
Terrace Floor	0.00	0.00	0.00	0.00
Total	95.42	95.42	95.42	95.42

Building USE/SUBUSE Details

Building Name	Building Use	Building SubUse	Building Structure
A1 (RESIDENTIAL)	Residential	Bungalow/ Dwelling / Non Apartment	Non-Highrise

LTP NAME AND SIGNATURE	STRUCTURAL ENG'S NAME AND SIGNATURE	BUILDER NAME AND SIGNATURE	DIGITAL SIGNATURE
MAHENDRA MEHTA SINPC/DFTMN/0002/2022			

Proposal Basic Information	
Proposal File No.	SINPC/0436/W15/2023
Owner Name	JABLEN SAMAD
Khata No	45
Plot No	2073
Village Name	Simdega
Use	Residential
SubUse	Bungalow/ Dwelling / Non Apartment

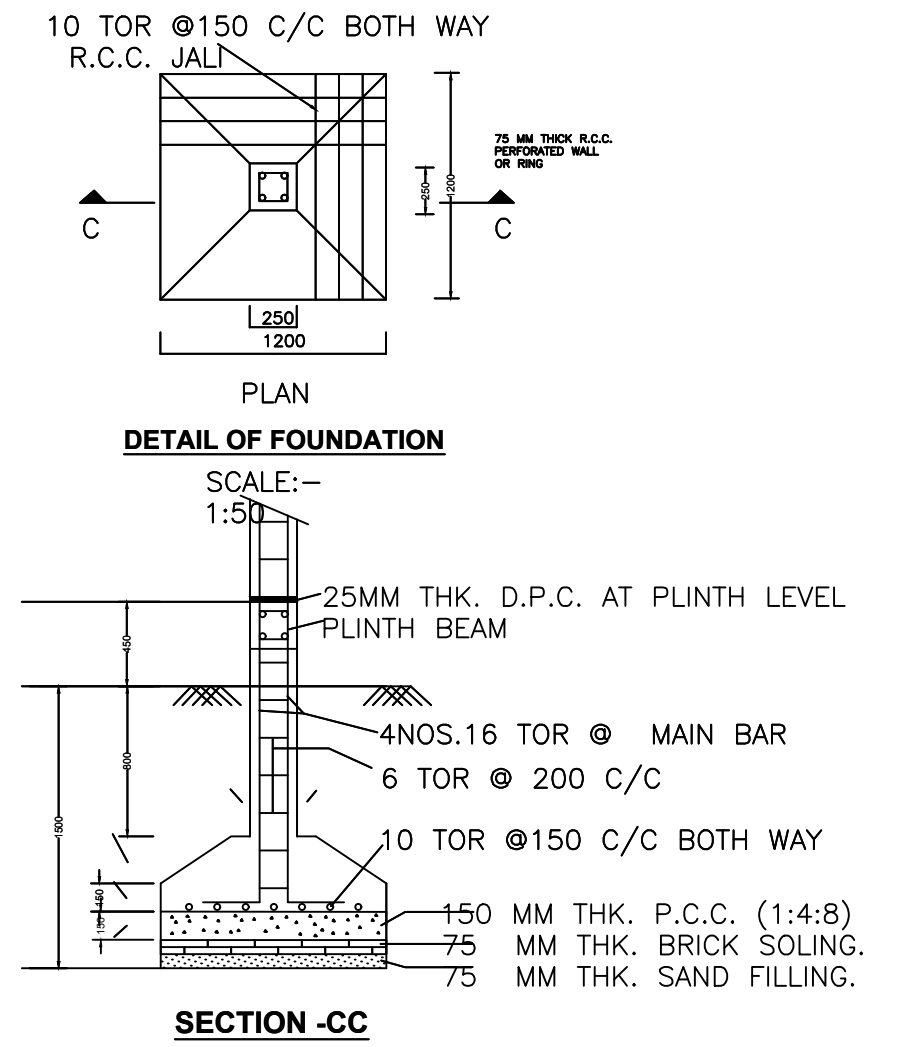
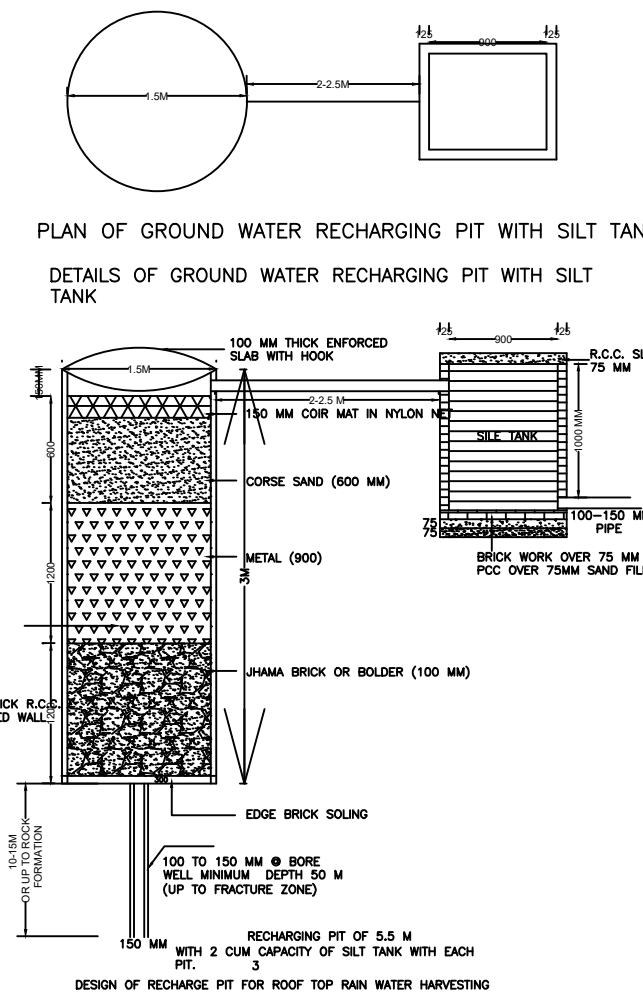
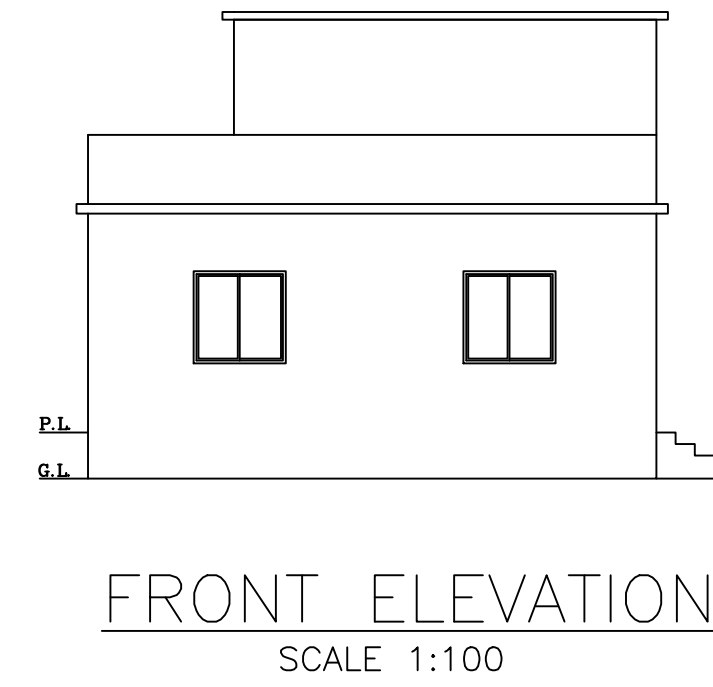
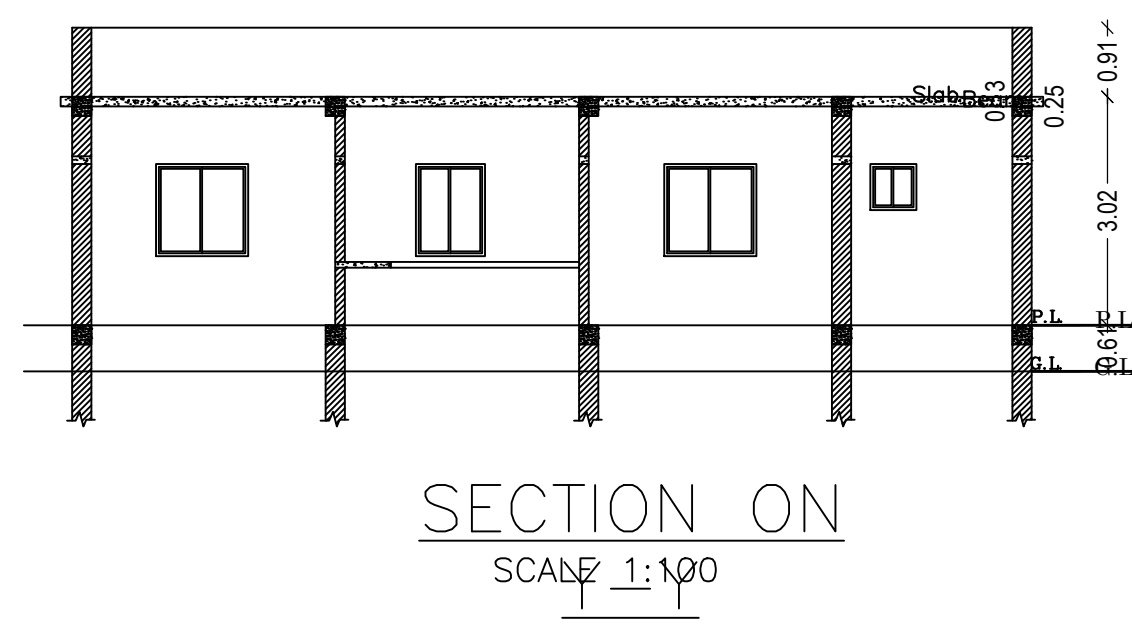
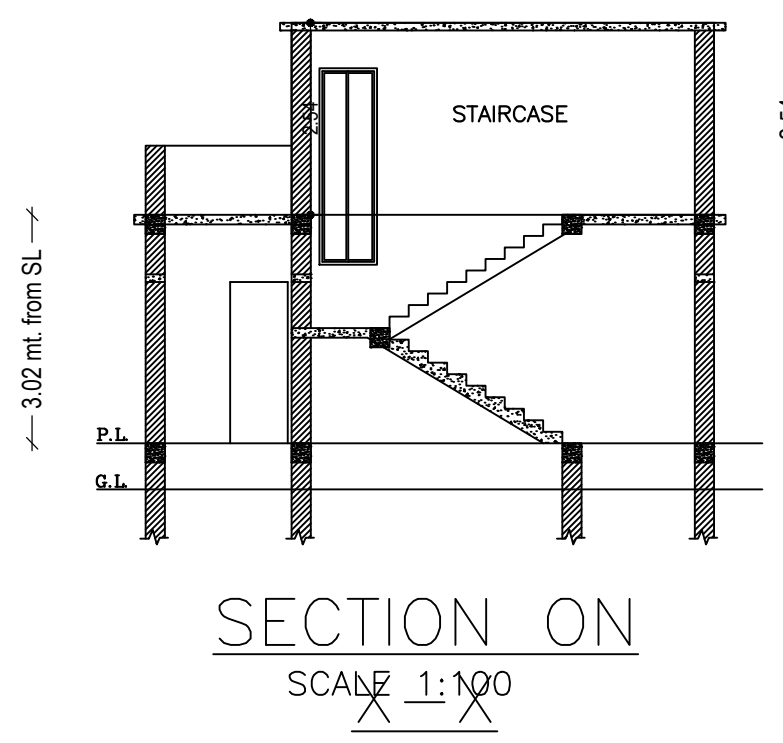
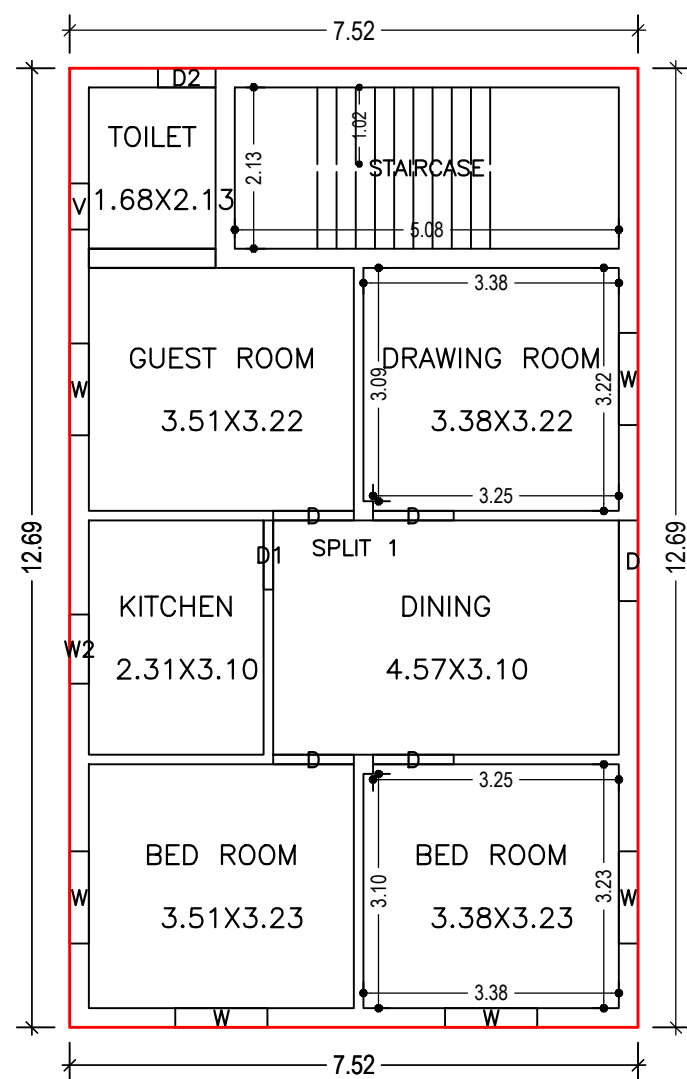

GROUND FLOOR PLAN (Proposed) (SCALE 1:100)

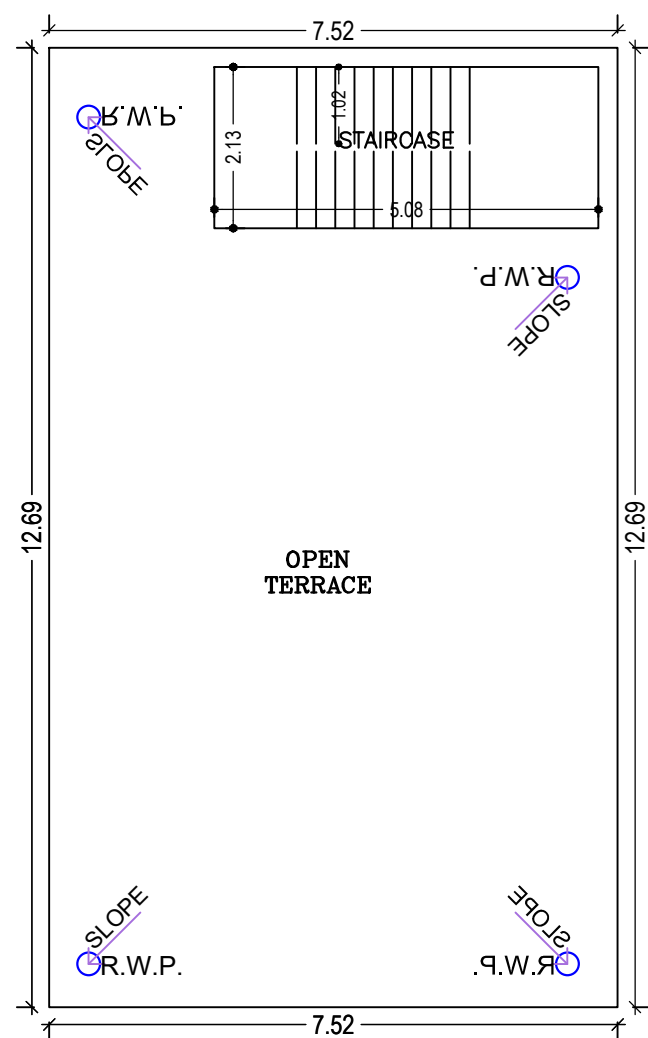

TERRACE FLOOR PLAN (SCALE 1:100)

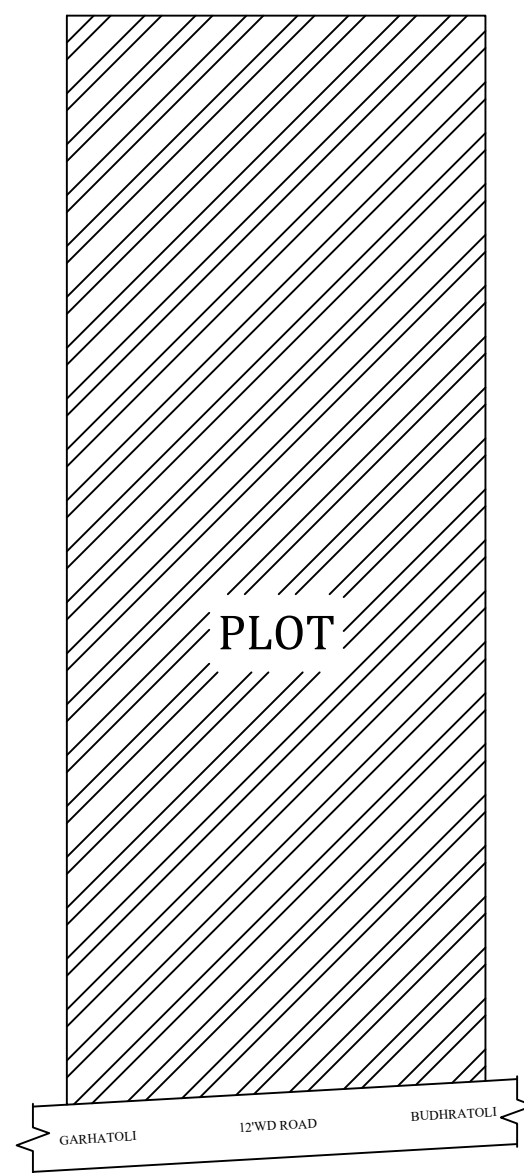

LOCATION PLAN NOT IN SCALE

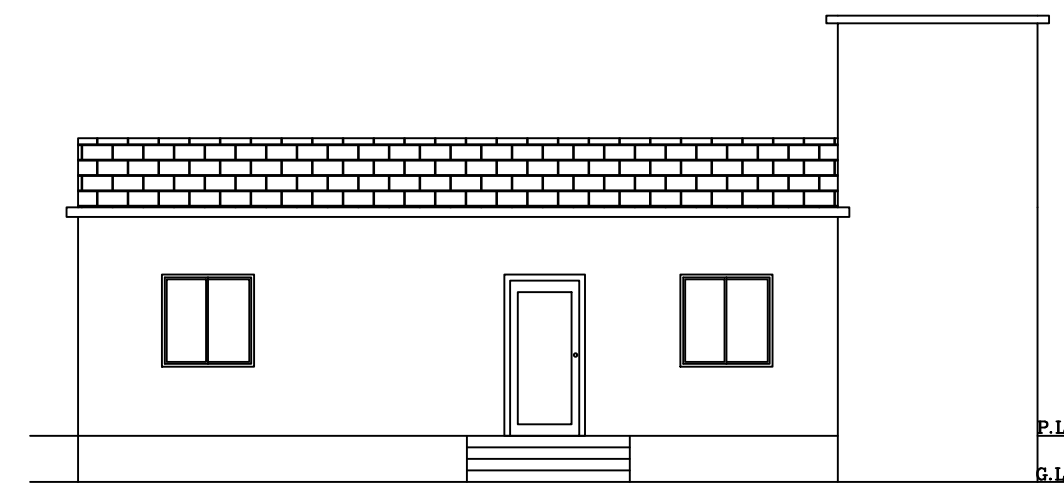

RIGHT SIDE ELEVATION SCALE 1:100

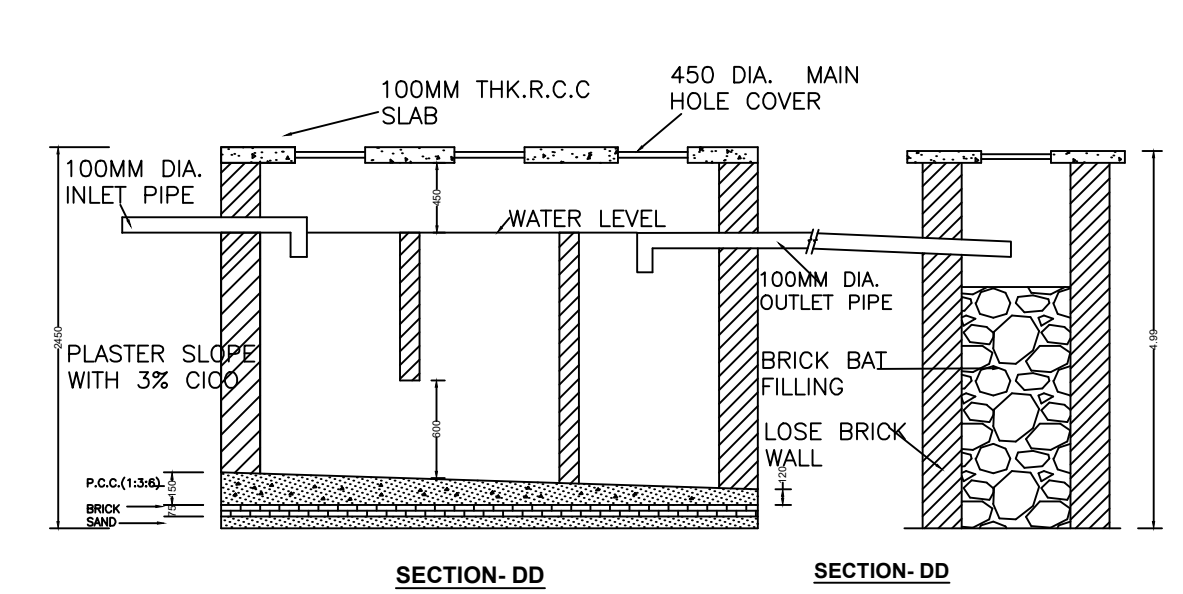
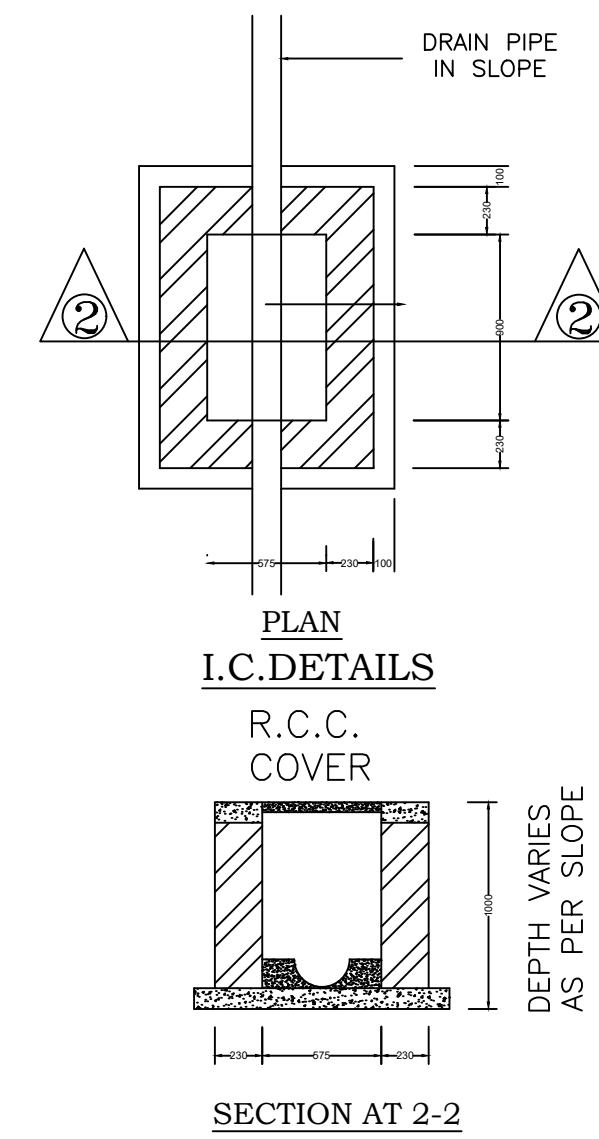

DETAIL OF SEPTIC TANK & SOAKPIT.

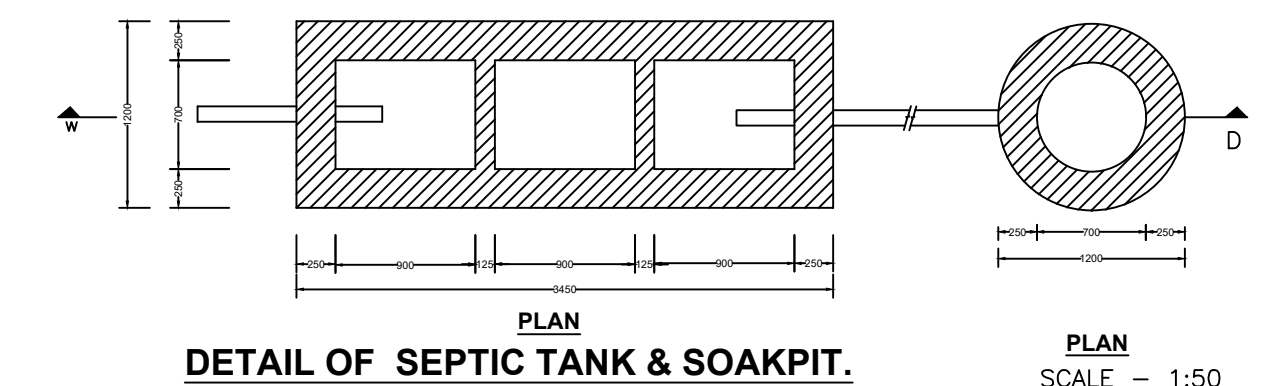

Building :A1 (RESIDENTIAL)

Floor Name	Total Built Up Area (Sq.mt.)	Proposed FAR Area (Sq.mt.)	Total FAR Area (Sq.mt.)	Total Consumed Additional FAR Area (Sq.mt.)	Tnmt (No.)
Ground Floor	95.42	95.42	95.42	95.42	01
Terrace Floor	0.00	0.00	0.00	0.00	00
Total :	95.42	95.42	95.42	95.42	01
Total Number of Same Buildings	1				
Total :	95.42	95.42	95.42	95.42	01

SCHEDULE OF DOOR:

BUILDING NAME	NAME	LENGTH	HEIGHT	NOS
A1 (RESIDENTIAL)	D2	0.76	2.10	01
A1 (RESIDENTIAL)	D1	0.91	2.10	01
A1 (RESIDENTIAL)	D	1.07	2.10	05

SCHEDULE OF WINDOW/VENTILATION:

BUILDING NAME	NAME	LENGTH	HEIGHT	NOS
A1 (RESIDENTIAL)	V	0.61	1.20	01
A1 (RESIDENTIAL)	W2	0.91	1.20	01
A1 (RESIDENTIAL)	W	1.22	1.20	06

UnitBUA Table for Building :A1 (RESIDENTIAL)

FLOOR	Name	UnitBUA Type	UnitBUA Area	Carpet Area	No. of Rooms	No. of Tenement
GROUND FLOOR PLAN	SPLIT 1	FLAT	72.67	72.25	7	1
Total:	-	-	72.67	72.25	7	1

LTP NAME AND SIGNATURE	STRUCTURAL ENG'S NAME AND SIGNATURE	BUILDER NAME AND SIGNATURE	DIGITAL SIGNATURE
MAHENDRA MEHTA SINPC/DFTMN/0002/2022			

Proposal Basic Information

Proposal File No.	SINPC/SP/0436/W15/2023
Owner Name	JABLEN SAMAD
Khata No	45
Plot No	2073
Village Name	Simdega
Use	Residential
SubUse	Bungalow/ Dwelling / Non Apartment

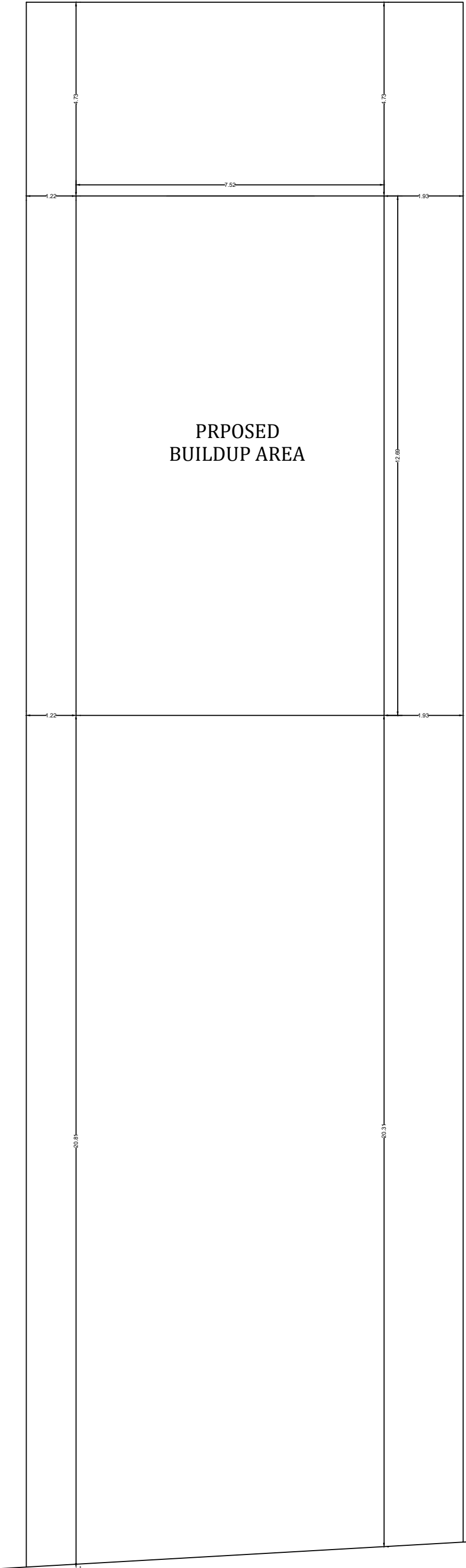

KEY PLAN
SCALE 1:200

LTP NAME AND SIGNATURE	STRUCTURAL ENG'S NAME AND SIGNATURE	BUILDER NAME AND SIGNATURE	DIGITAL SIGNATURE
MAHENDRA MEHTA SINPC/DFTMN/0002/2022			