

Proposal Basic Information	
Proposal File No.	SINPC/BP/0441/W07/2023
Owner Name	KALYAN EKKA
Khata No	114
Plot No	546
Village Name	Khijri
Use	Residential
SubUse	Bungalow/ Dwelling / Non Apartment

AREA STATEMENT SIMDEGA NAGAR PANCHAYAT		VERSION NO.: 1.0.66
PROJECT DETAIL:		VERSION DATE: 16/10/2020
Region: JHARKHAND URBAN LOCAL BODIES	Plot Use: Residential	
District: SIMDEGA	Plot SubUse: Bungalow/ Dwelling / Non Apartment	
Authority: SIMDEGA NAGAR PANCHAYAT	PlotNearbyReligiousStructure: NA	
Inward No: SINPC/BP/0441/W07/2023	Plot/SubPlot No: 546	
Application Type: General Proposal	North: -	
Project Type: Building Permission	South: -	
Nature of Development: New	East: -	
Location of Development Area: Old Area	West: -	
AREA DETAILS:		SQ.MT.
AREA OF PLOT (Minimum)	(A)	101.88
NET AREA OF PLOT(Gross Plot Area - Deduction from Gross Plot area)	(A-Deductions)	101.88
Deduction for Balance Plot Area(from Gross Plot Area)		
Common Plot		7.93
Total		7.93
BALANCE AREA OF PLOT(Net Plot Area - Recreational/Amenity space)	(A-Deductions)	93.95
PLOT AREA FOR COVERAGE(Net Plot Area)	(A-Deductions)	101.88
Plot Area for FAR (Net Plot Area + RoadWidening Area)	(A-Deductions)	101.88
COVERAGE CHECK		
Permissible Coverage area ( 70.00 % )		71.32
Proposed Coverage Area ( 46.76 % )		47.64
Total Prop. Coverage Area ( 46.76 % )		47.64
Balance coverage area ( 23.24 % )		23.68
FAR CHECK		
Perm. FAR Area ( 1.800 )		183.38
Total Perm. FAR area		183.38
Residential FAR		142.93
Proposed FAR Area		142.93
Total Proposed FAR Area		142.93
Consumed FAR (Factor)		1.40
Balance FAR Area		40.45
BUILT UP AREA CHECK		
Total Proposed BuiltUp Area		142.92
ARCHITECT (Regd)	MAHENDRA MEHTA	
ENGINEER (Regd)		
SUPERVISOR (Regd)		
OWNER (Regd)	KALYAN EKKA	
DEVELOPMENT AUTHORITY	LOCAL BODY	

Buildingwise Floor FAR Details

Floor Name	Building Name		Total	
	Proposed Built Up Area (Sq.mt.)	Proposed FAR Area (Sq.mt.)	Total Proposed Built Up Area (Sq.mt.)	Total FAR Area (Sq.mt.)
Ground Floor	47.64	47.64	47.64	47.64
First Floor	47.64	47.64	47.64	47.64
Second Floor	47.64	47.64	47.64	47.64
Terrace Floor	0.00	0.00	0.00	0.00
Total :	142.92	142.92	142.92	142.92

Building USE/SUBUSE Details

Building Name	Building Use	Building SubUse	Building Structure
A1 (RESIDENTIAL)	Residential	Bungalow/ Dwelling / Non Apartment	Non-Highrise

COLOR INDEX	
PLOT BOUNDARY	Black
ABUTTING ROAD	Green
PROPOSED CONSTRUCTION	Red
COMMON PLOT	Yellow
ROAD WIDENING AREA	Blue
EXISTING (To be retained)	Orange
EXISTING (To be demolished)	Light Blue

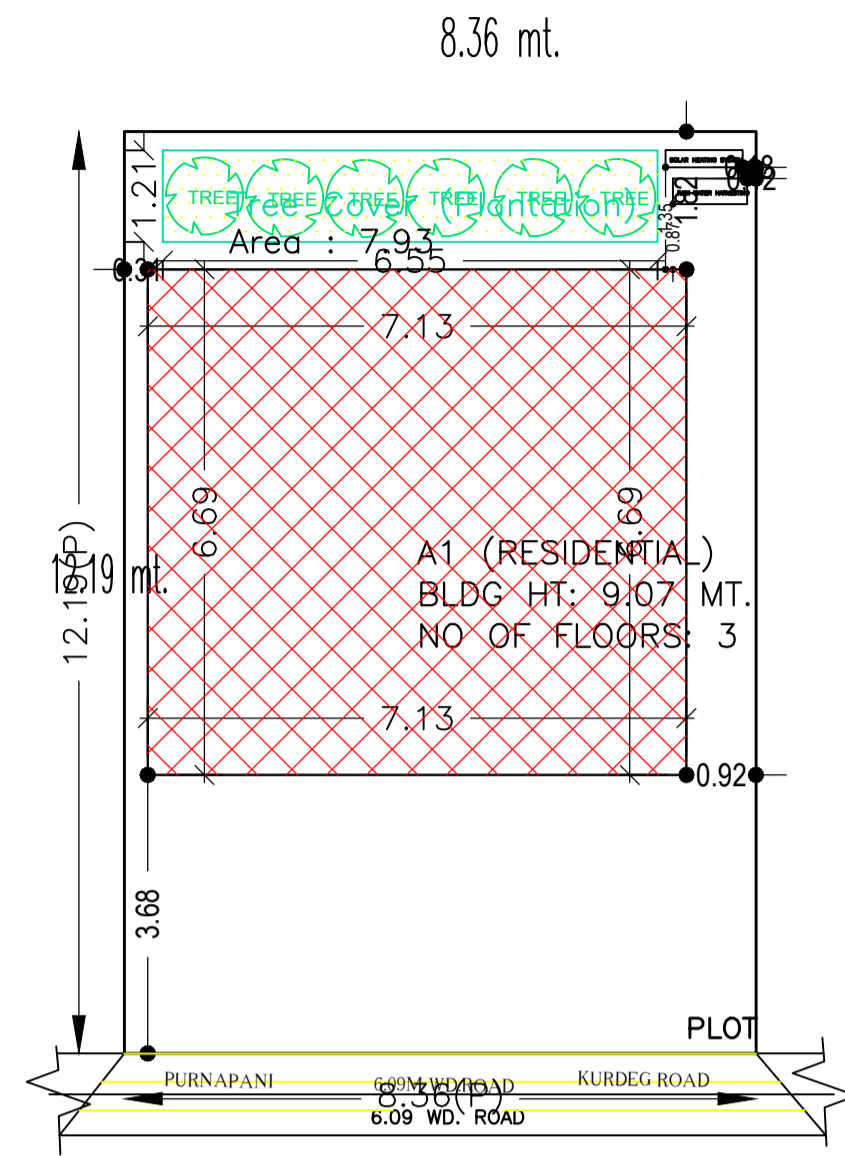

SITE PLAN

LTP NAME AND SIGNATURE	STRUCTURAL ENG'S NAME AND SIGNATURE	BUILDER NAME AND SIGNATURE	DIGITAL SIGNATURE
MAHENDRA MEHTA SINPC/DFTMN/0002/2022			

Proposal Basic Information

Proposal File No.	SINPCBP/0441/W07/2023
Owner Name	KALYAN EKKA
Khata No	114
Plot No	546
Village Name	Khijri
Use	Residential
SubUse	Bungalow/ Dwelling / Non Apartment

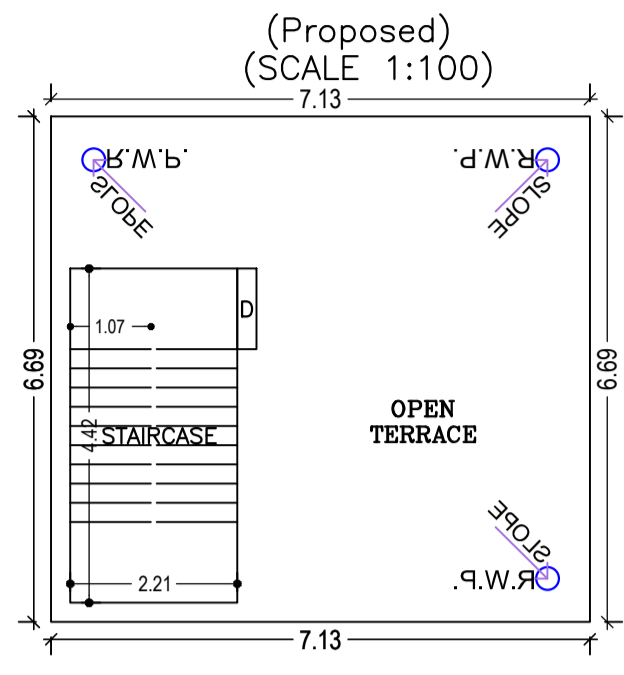

TERRACE FLOOR PLAN (Proposed) (SCALE 1:100)

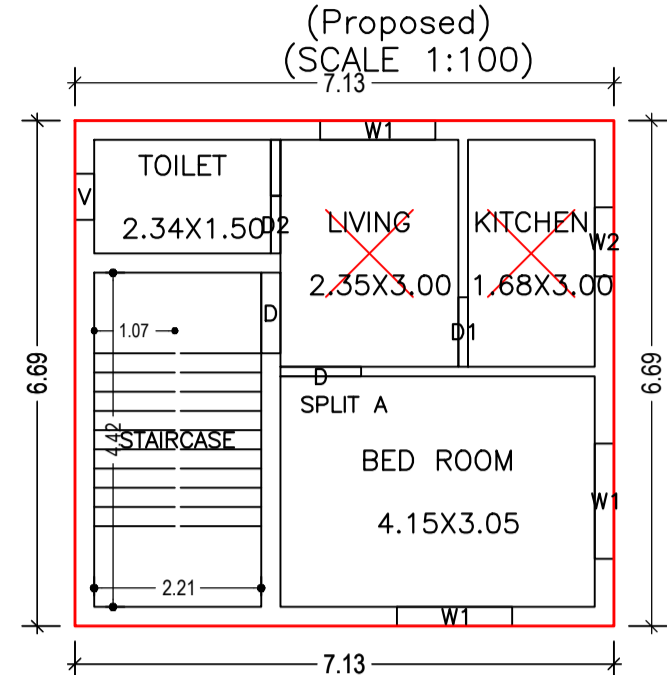

SECOND FLOOR PLAN (Proposed) (SCALE 1:100)

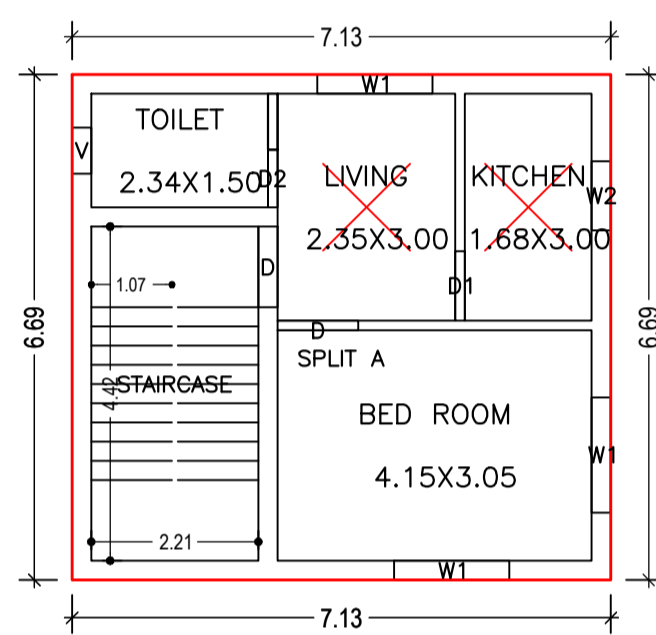

FIRST FLOOR PLAN (Proposed) (SCALE 1:100)

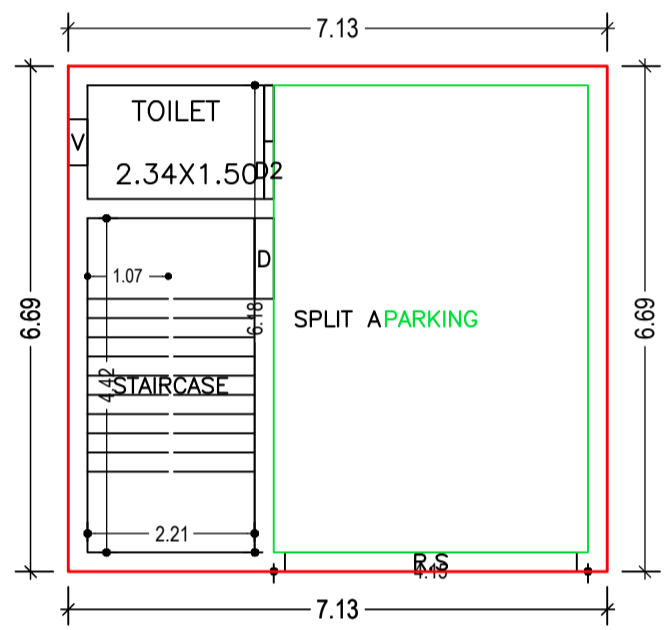

GROUND FLOOR PLAN (Proposed) (SCALE 1:100)

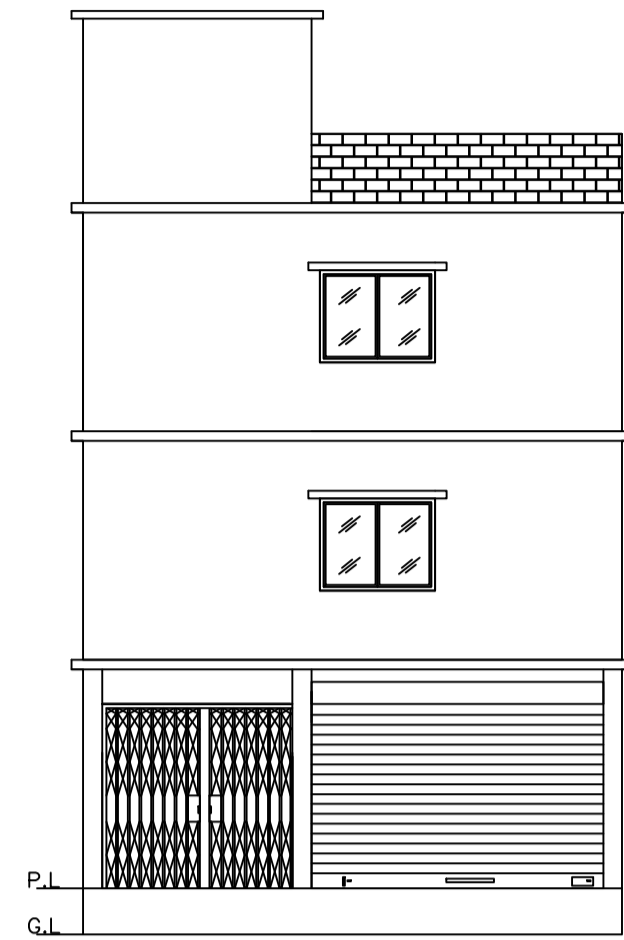

FRONT ELEVATION (SCALE 1:100)

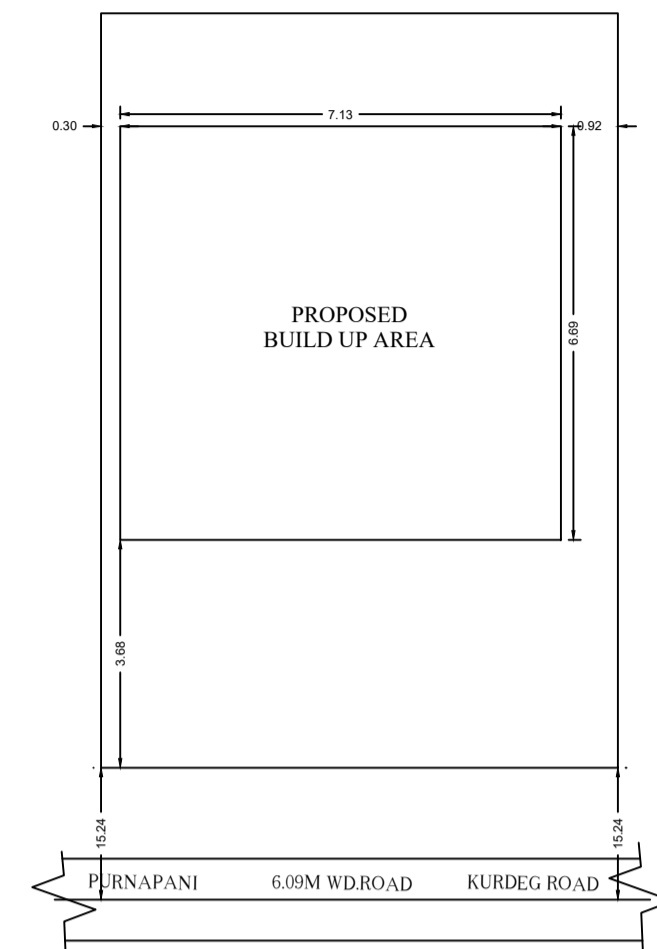

KEY PLAN (SCALE 1:100)

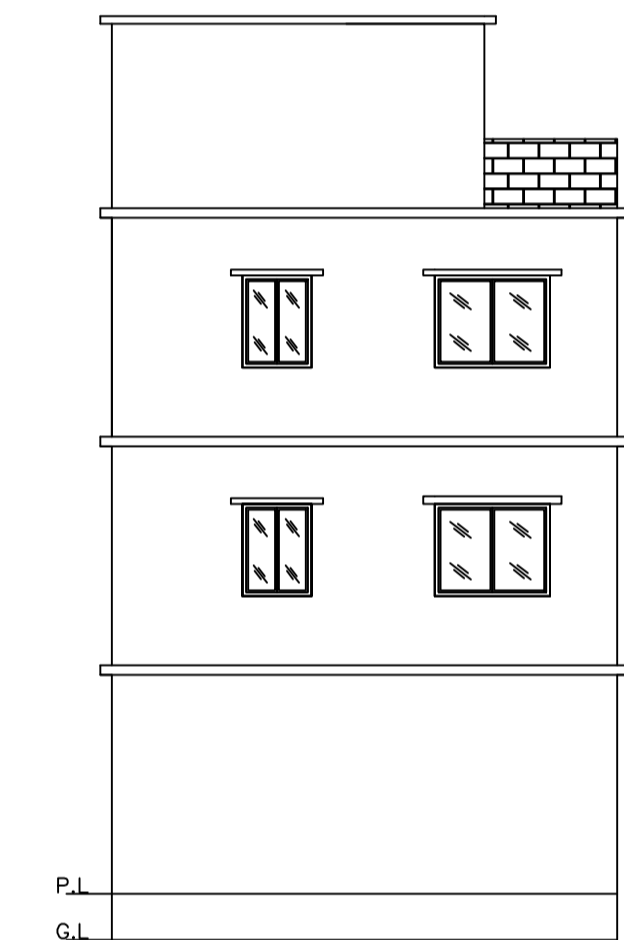

RIGHT SIDE ELEVATION (SCALE 1:100)

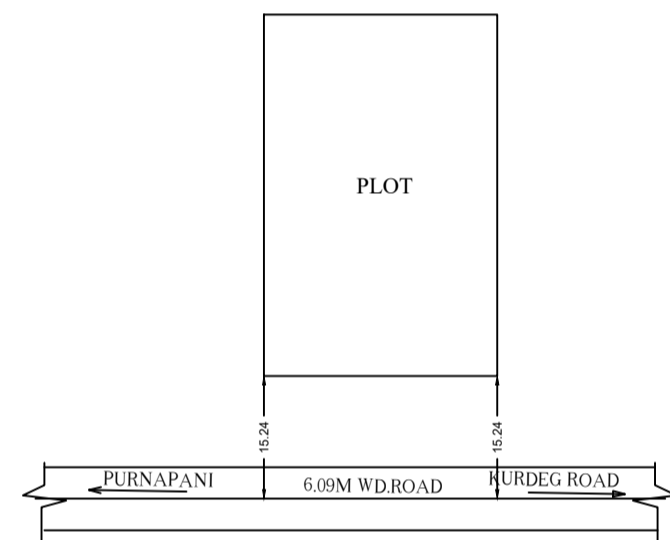

LOCATION PLAN (NOT TO SCALE)

Building :A1 (RESIDENTIAL)

Floor Name	Total Built Up Area (Sq.mt.)	Proposed FAR Area (Sq.mt.) Rest.	Total FAR Area (Sq.mt.)	Total Consumed Additional FAR Area (Sq.mt.)	Trmt (No.)
Ground Floor	47.64	47.64	47.64	47.64	01
First Floor	47.64	47.64	47.64	47.64	00
Second Floor	47.64	47.64	47.64	47.64	00
Terrace Floor	0.00	0.00	0.00	0.00	00
Total :	142.92	142.92	142.92	142.92	01
Total Number of Same Buildings :	1				
Total :	142.92	142.92	142.92	142.92	01

UnitBUA Table for Building :A1 (RESIDENTIAL)

FLOOR	Name	UnitBUA Type	UnitBUA Area	Carpet Area	No. of Rooms	No. of Tenement
GROUND FLOOR PLAN	SPLIT A	FLAT	88.11	87.83	1	1
FIRST FLOOR PLAN	SPLIT A	FLAT	0.00	0.00	4	0
SECOND FLOOR PLAN	SPLIT A	FLAT	0.00	0.00	4	0
Total:	-	-	88.11	87.83	9	1

SCHEDULE OF DOOR:

BUILDING NAME	NAME	LENGTH	HEIGHT	NOS
A1 (RESIDENTIAL)	D2	0.76	2.10	03
A1 (RESIDENTIAL)	D1	0.92	2.10	02
A1 (RESIDENTIAL)	D	1.07	2.10	04

SCHEDULE OF WINDOW/VENTILATION:

BUILDING NAME	NAME	LENGTH	HEIGHT	NOS
A1 (RESIDENTIAL)	V	0.61	1.20	03
A1 (RESIDENTIAL)	W2	0.91	1.20	02
A1 (RESIDENTIAL)	W1	1.52	1.20	06

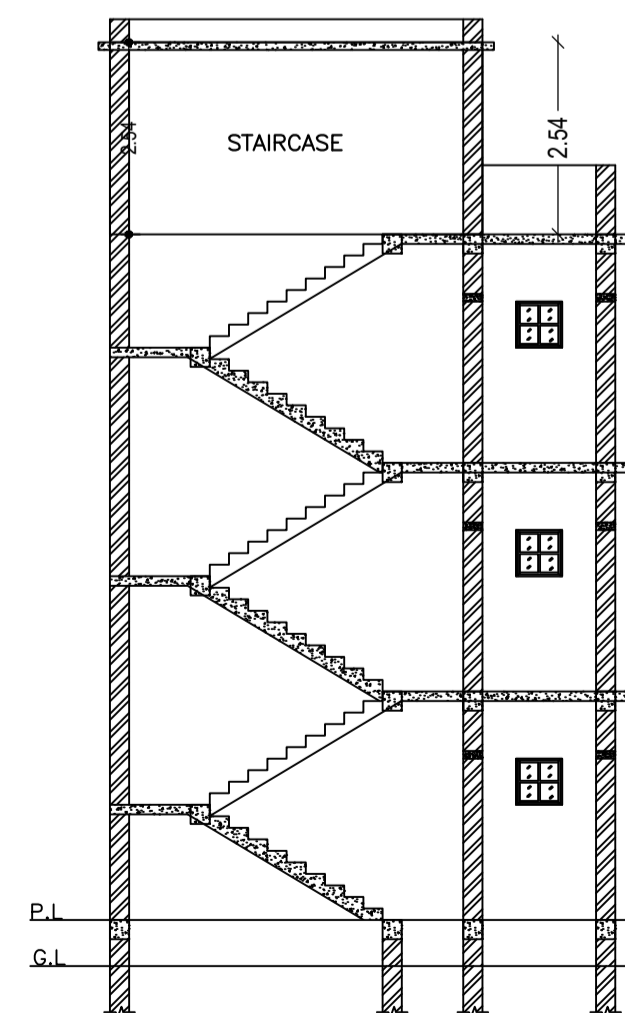

SECTION Y-Y (SCALE 1:100)

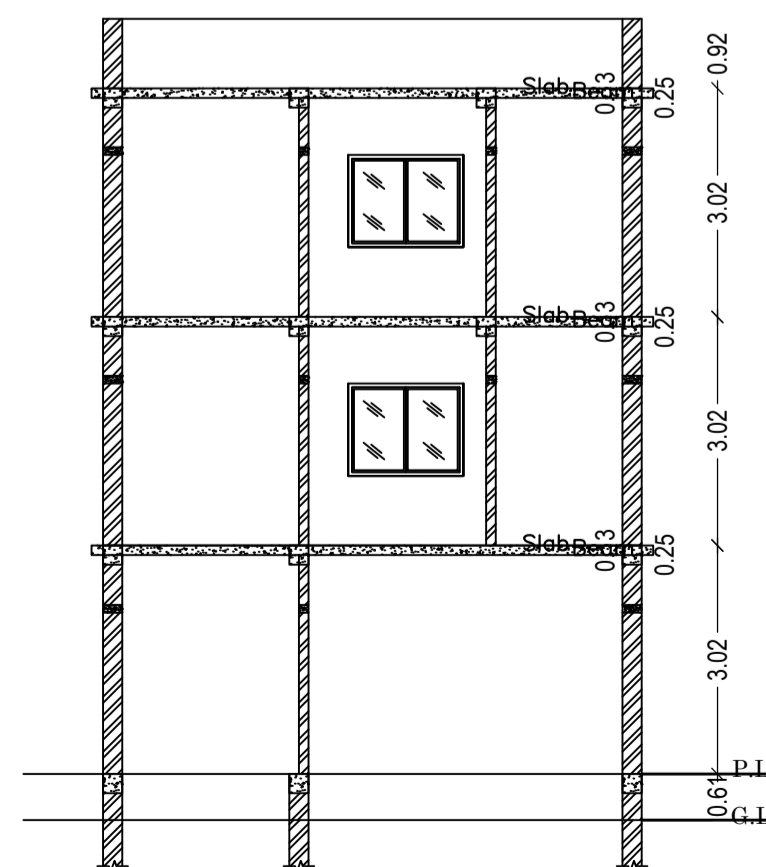

SECTION X-X (SCALE 1:100)

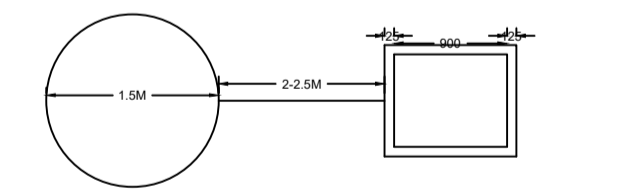

PLAN OF GROUND WATER RECHARGING PIT WITH SILT TANK

DETAILS OF GROUND WATER RECHARGING PIT WITH SILT TANK

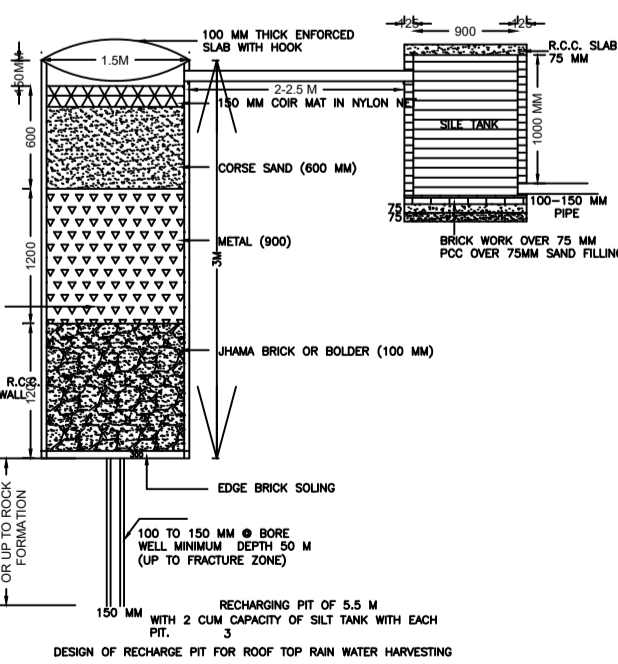

DESIGN OF RECHARGE PIT FOR ROOF TOP RAIN WATER HARVESTING

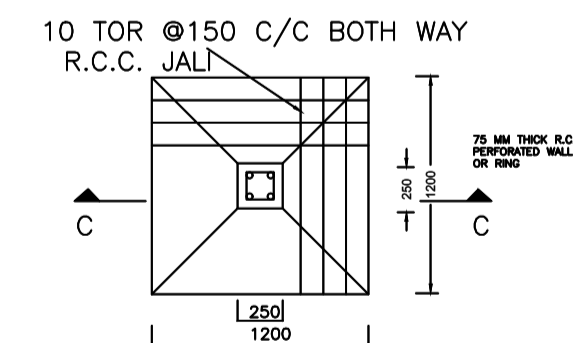

DETAIL OF FOUNDATION

SCALE:- 1:5

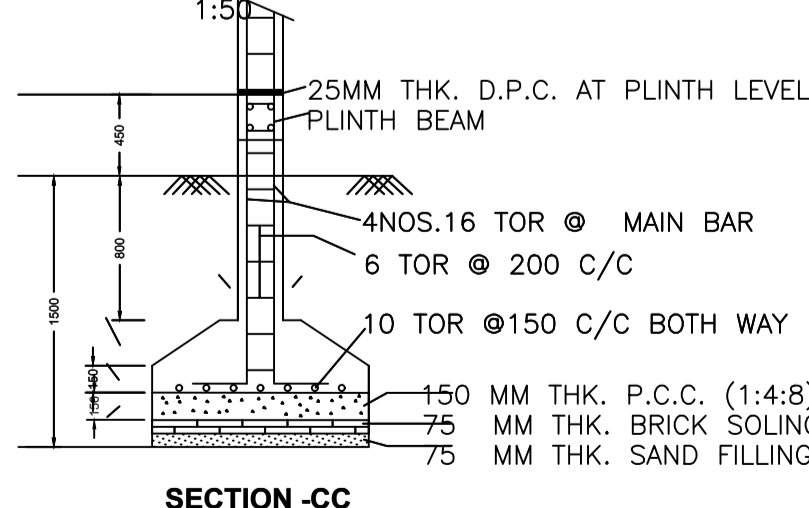

SECTION CC

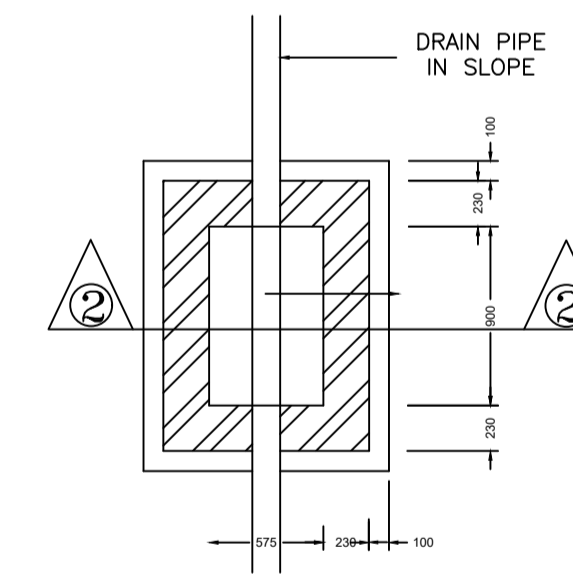

PLAN I.C. DETAILS

R.C.C. COVER

SECTION AT 2-2

DEPTH VARIES AS PER SLOPE

SECTION AT 2-2

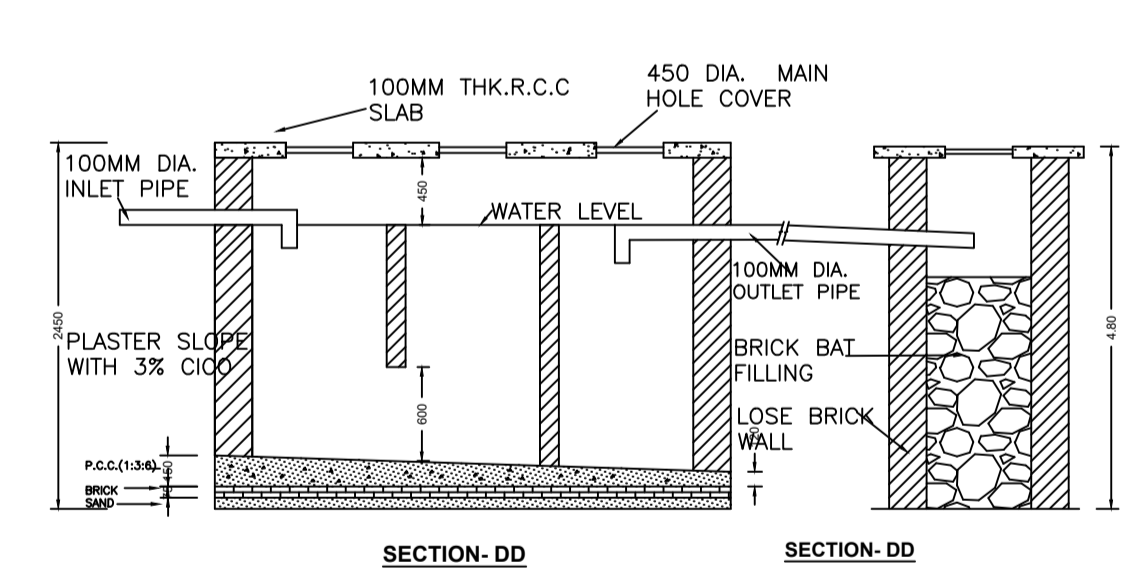

SECTION DD

SECTION DD

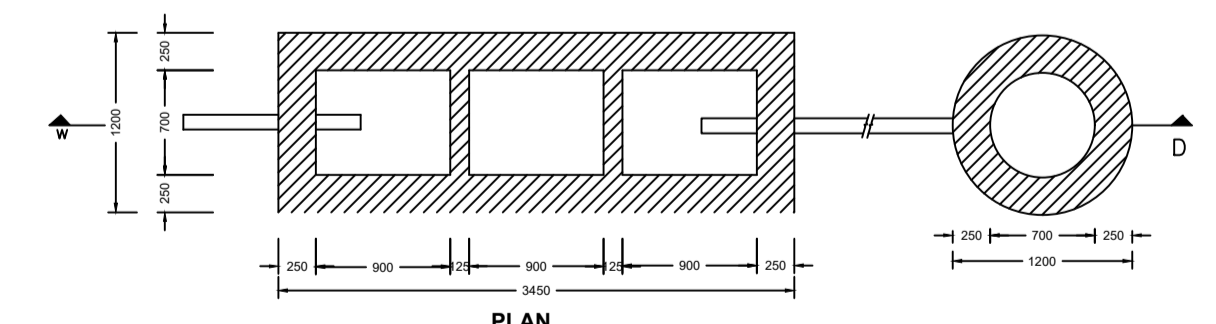

DETAIL OF SEPTIC TANK & SOAKPIT.

SCALE - 1:50

LTP NAME AND SIGNATURE	STRUCTURAL ENG'S NAME AND SIGNATURE	BUILDER NAME AND SIGNATURE	DIGITAL SIGNATURE
MAHENDRA MEHTA SINPC/DFTMN/0002/2022			