

SITE PLAN

FAR & Tenement Details (Table 4c-1)

Building	No. of Same Bldg	Total Built Up Area (Sq.mt.)	Deductions (Area in Sq.mt.)		Proposed FAR Area (Sq.mt.)	Total FAR Area (Sq.mt.)	Total Consumed Additional FAR Area (Sq.mt.)	Trmnt (No.)
			Balcony	Resi.				
NISHA SURIN (A BUILDING)	1	254.05	2.49		251.56	251.56	251.56	01
Grand Total :	1	254.05	2.49		251.56	251.56	251.56	01

Proposal Basic Information

Proposal File No.	SINPC/BP/0442/W16/2023
Owner Name	NISHA SURIN
Khata No	41
Plot No	1937
Village Name	Simdega
Use	Residential
SubUse	Bungalow/ Dwelling / Non Apartment

AREA STATEMENT SIMDEGA NAGAR PANCHAYAT		VERSION NO. : 1.0.66
PROJECT DETAIL		VERSION DATE: 16/10/2020
Region: JHARKHAND URBAN LOCAL BODIES	Plot Use: Residential	
District: SIMDEGA	Plot SubUse: Bungalow/ Dwelling / Non Apartment	
Authority: SIMDEGA NAGAR PANCHAYAT	PlotNearbyReligiousStructure: NA	
Inward No: SINPC/BP/0442/W16/2023	PlotSubPlot No: 1937	
Application Type: General Proposal	North: Plot No. - 1937	
Project Type: Building Permission	South: Plot No. - 1937	
Nature of Development: New	East: Road Width - 3.65	
Location of Development Area: Old Area	West: Plot No. - 1937	
AREA DETAILS:		
AREA OF PLOT (Minimum)	(A)	283.42
NET AREA OF PLOT(Gross Plot Area - Deduction from Gross Plot area)	(A-Deductions)	283.42
Deduction for Balance Plot Area(from Gross Plot Area)		
Common Plot		35.76
Total		35.76
BALANCE AREA OF PLOT(Net Plot Area - Recreational/Amenity space)	(A-Deductions)	247.65
PLOT AREA FOR COVERAGE(Net Plot Area)	(A-Deductions)	283.42
Plot Area for FAR (Net Plot Area + Road Widening Area)	(A-Deductions)	283.42
COVERAGE CHECK		
Permissible Coverage area (60.00 %)		170.05
Proposed Coverage Area (45.85 %)		129.96
Total Prop. Coverage Area (45.85 %)		129.96
Balance coverage area (14.15 %)		40.09
FAR CHECK		
Perm. FAR Area (1.500)		425.13
Total Perm. FAR area		425.13
Residential FAR		251.56
Proposed FAR Area		251.56
Total Proposed FAR Area		251.56
Consumed FAR (Factor)		0.89
Balance FAR Area		173.57
BUILT UP AREA CHECK		
Total Proposed BuiltUp Area		254.05
ARCHITECT (Regd)	ITMOON TIRKEY	
ENGINEER (Regd)		
SUPERVISOR (Regd)		
OWNER (Regd)	NISHA SURIN	
DEVELOPMENT AUTHORITY		LOCAL BODY

COLOR INDEX	
PLOT BOUNDARY	Black
ABUTTING ROAD	Green
PROPOSED CONSTRUCTION	Red
COMMON PLOT	Yellow
ROAD WIDENING AREA	Orange
EXISTING (To be retained)	Blue
EXISTING (To be demolished)	Light Blue

Buildingwise Floor FAR Details

Floor Name	Building Name		Total	
	Proposed Built Up Area (Sq.mt.)	Proposed FAR Area (Sq.mt.)	Total Proposed Built Up Area (Sq.mt.)	Total FAR Area (Sq.mt.)
Ground Floor	129.96	129.96	129.96	129.96
First Floor	124.09	121.60	124.09	121.60
Terrace Floor	0.00	0.00	0.00	0.00
Total :	254.05	251.56	254.05	251.56

Building USE/SUBUSE Details

Building Name	Building Use	Building SubUse	Building Structure
NISHA SURIN (A BUILDING)	Residential	Bungalow/ Dwelling / Non Apartment	Non-Highrise

LTP NAME AND SIGNATURE	STRUCTURAL ENG'S NAME AND SIGNATURE	BUILDER NAME AND SIGNATURE	DIGITAL SIGNATURE
ITMOON TIRKEY SINPC/DFTMN/0003/2022			

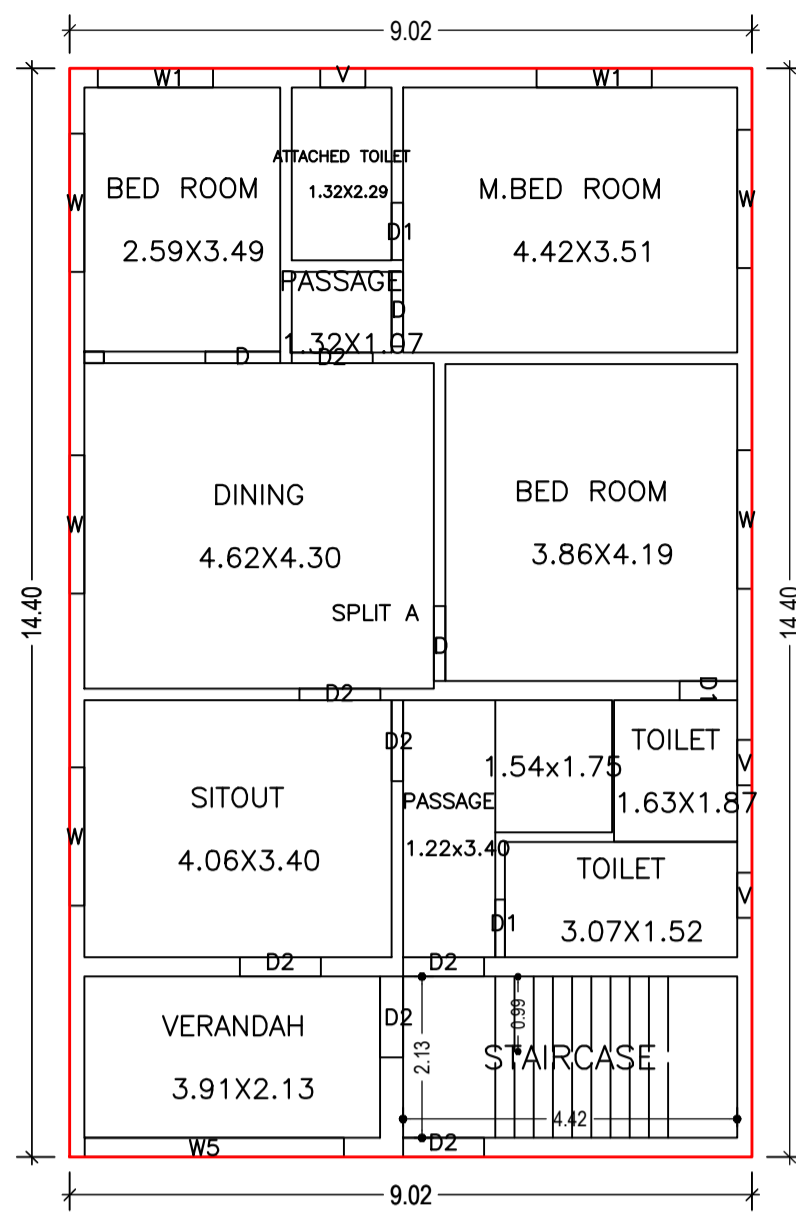

GROUND FLOOR PLAN (Proposed) (SCALE 1:100)

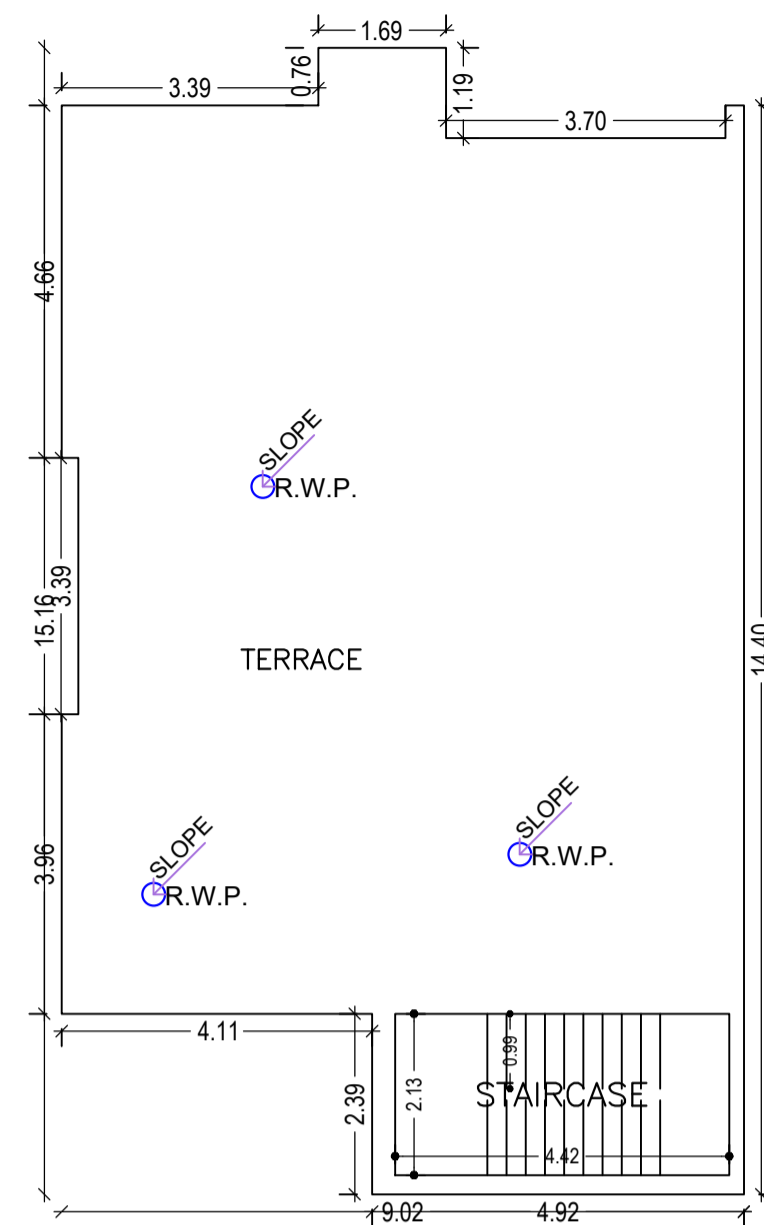

TERRACE FLOOR PLAN (SCALE 1:100)

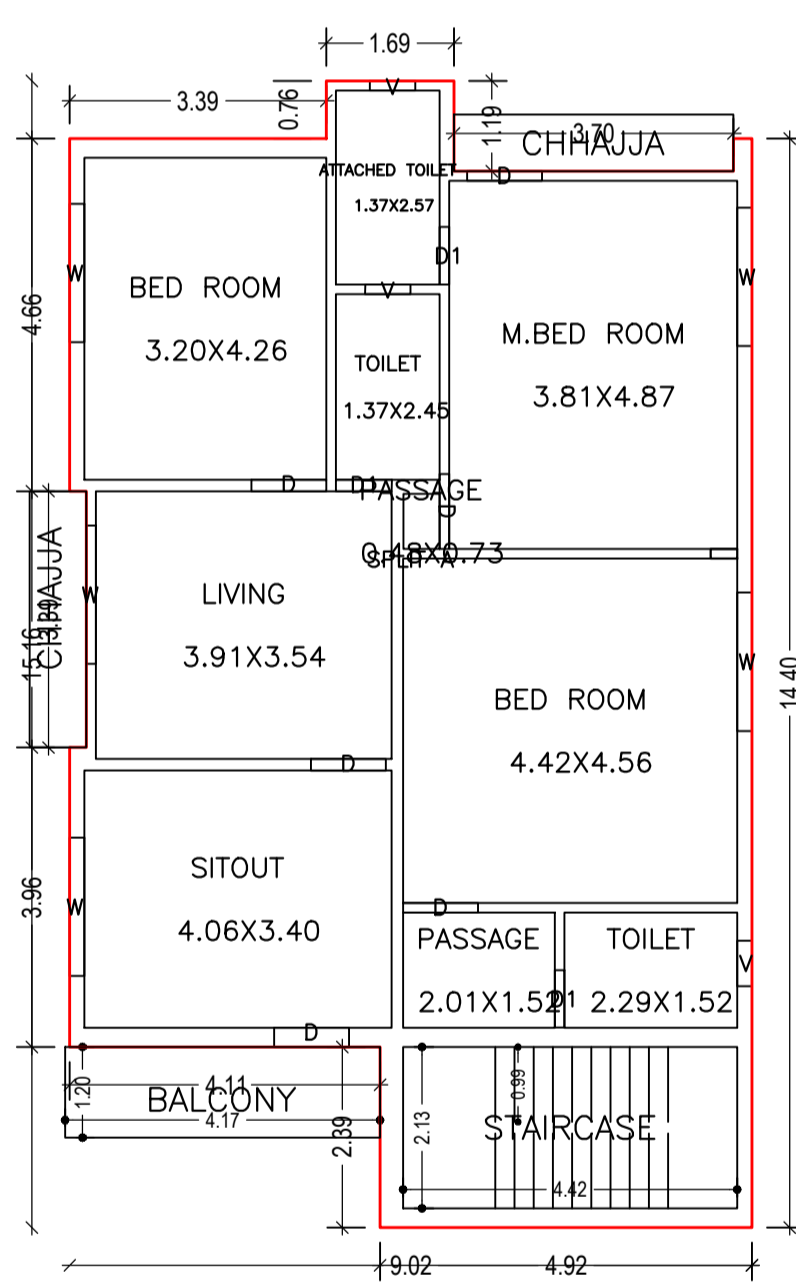

FIRST FLOOR PLAN (Proposed) (SCALE 1:100)

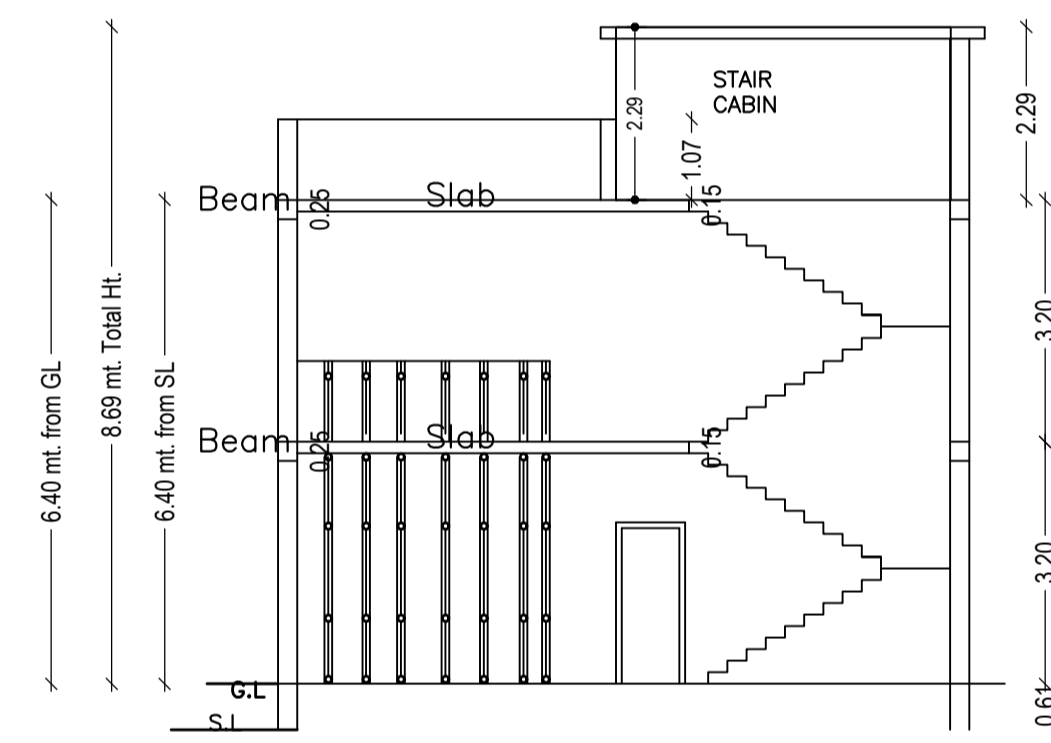

SECTION X-X

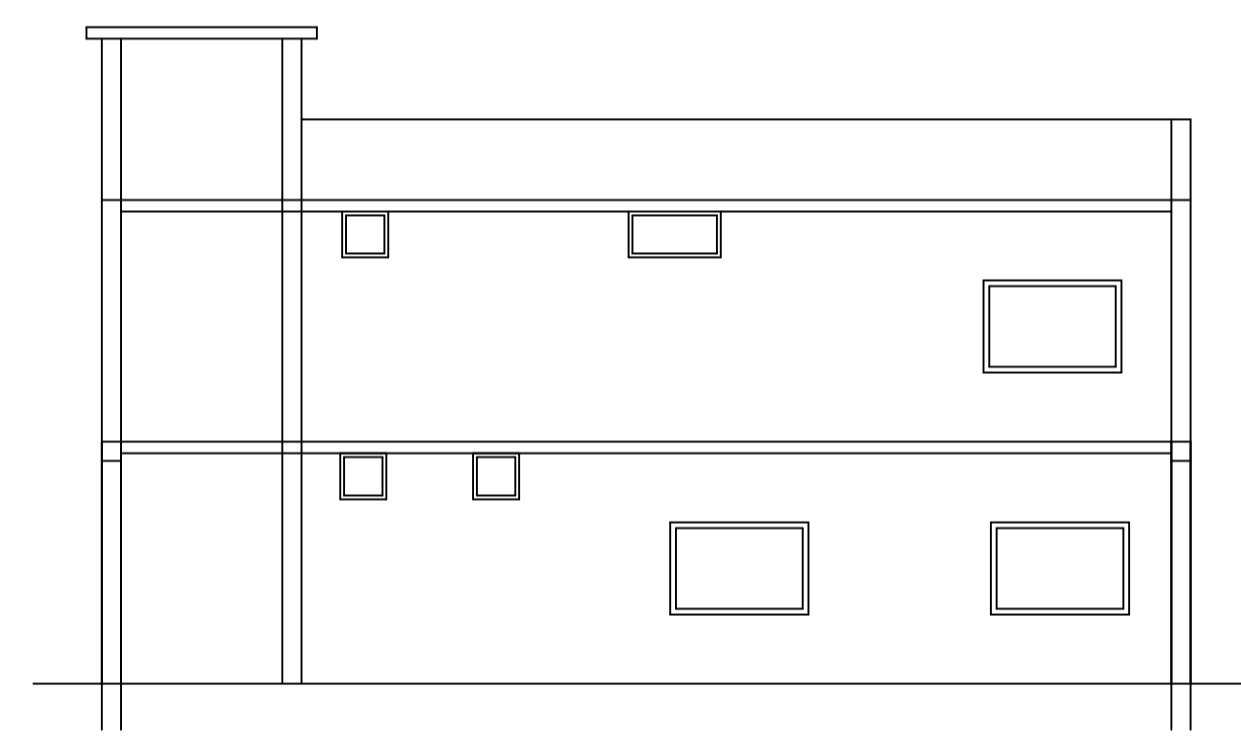

SECTION Y-Y

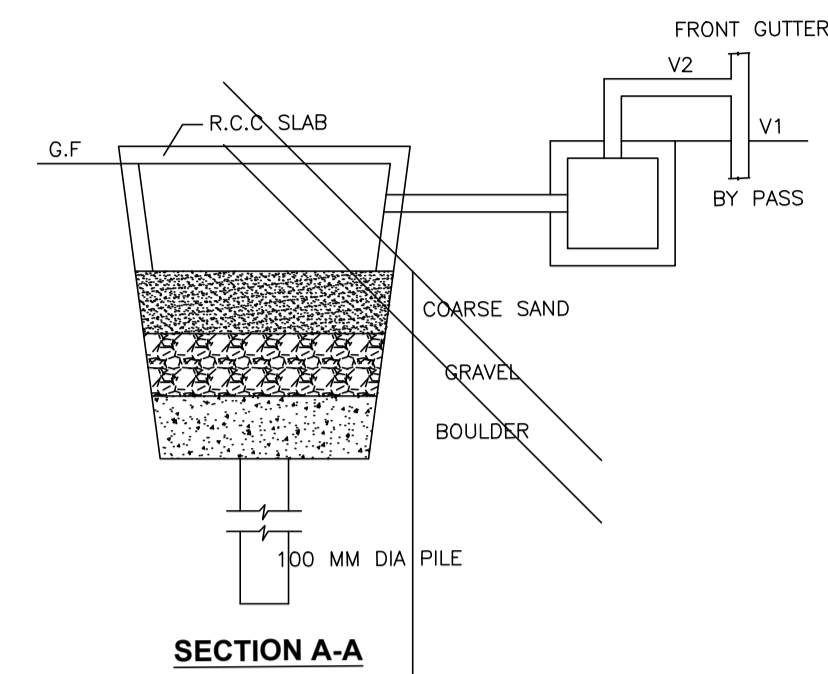

SECTION A-A

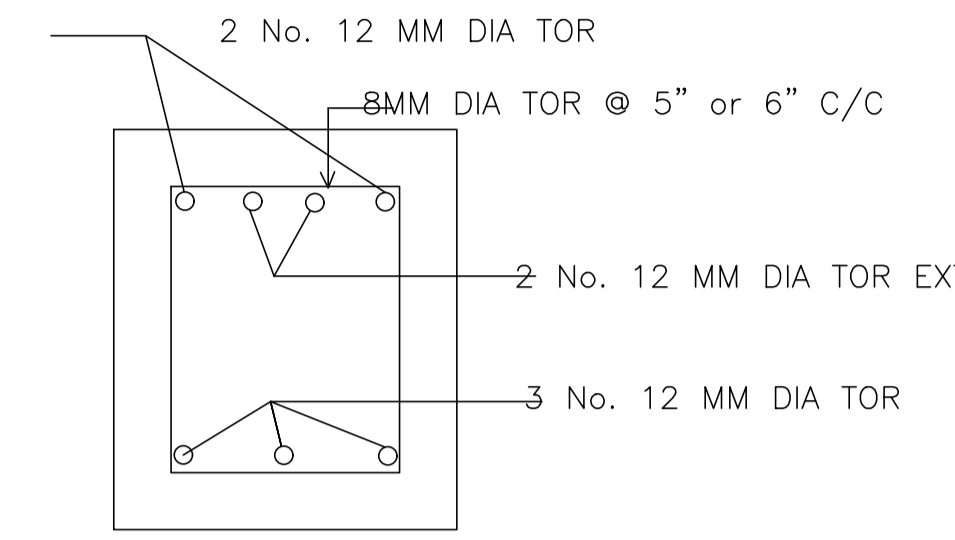

PLINTH BEAM SECTION AT Y - Y (NOT TO SCALE)

RECHARGEABLE BORE WELL

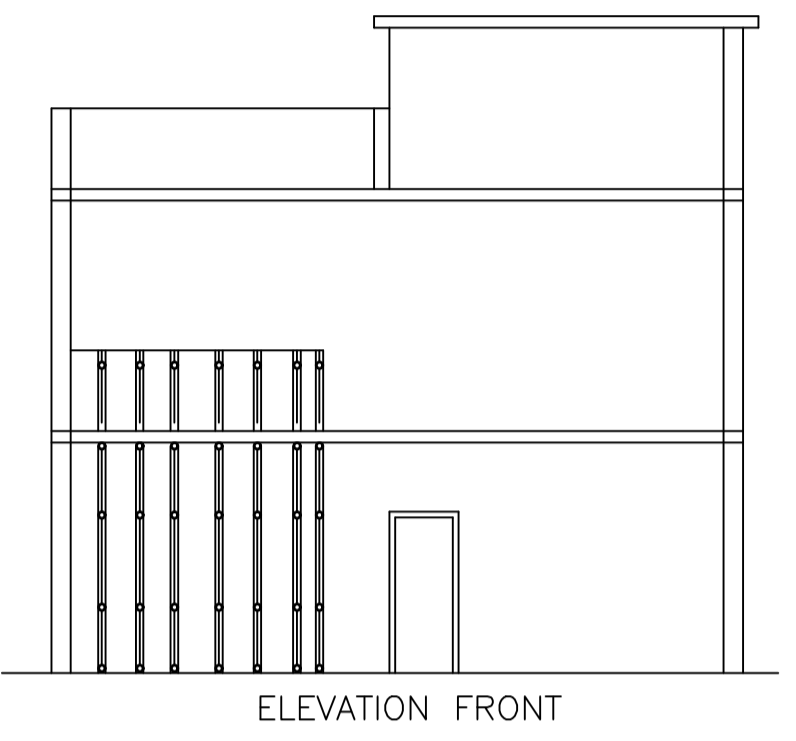

ELEVATION FRONT



LOCATION MAP

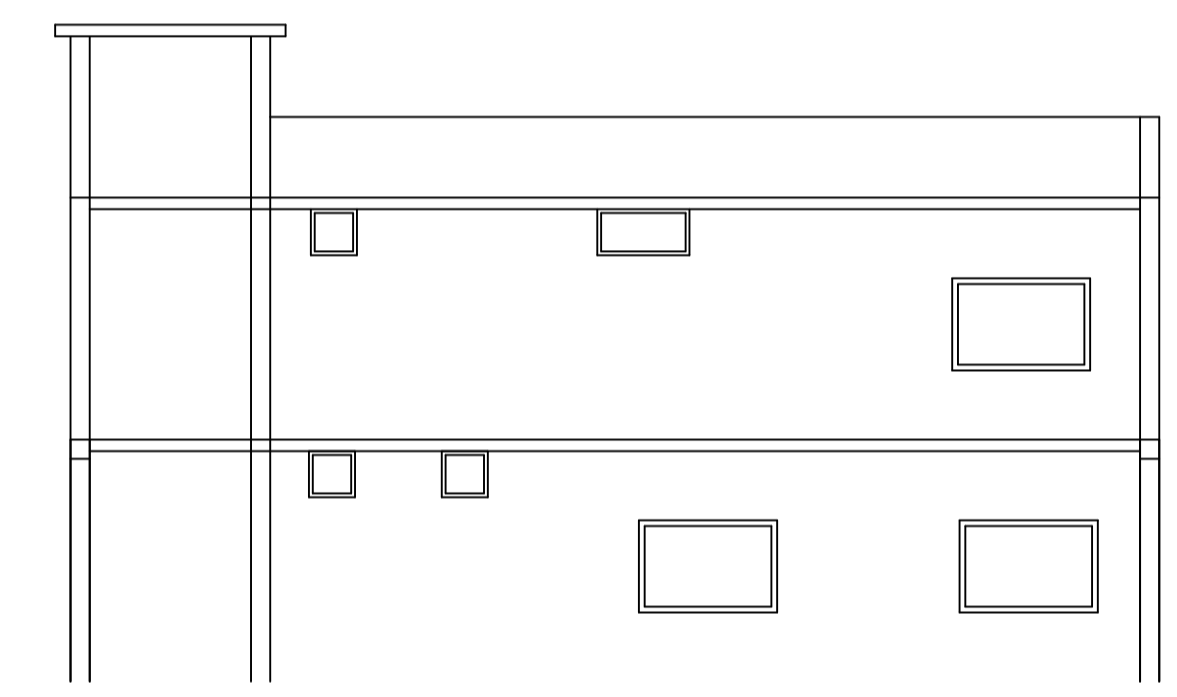

ELEVATION SIDE

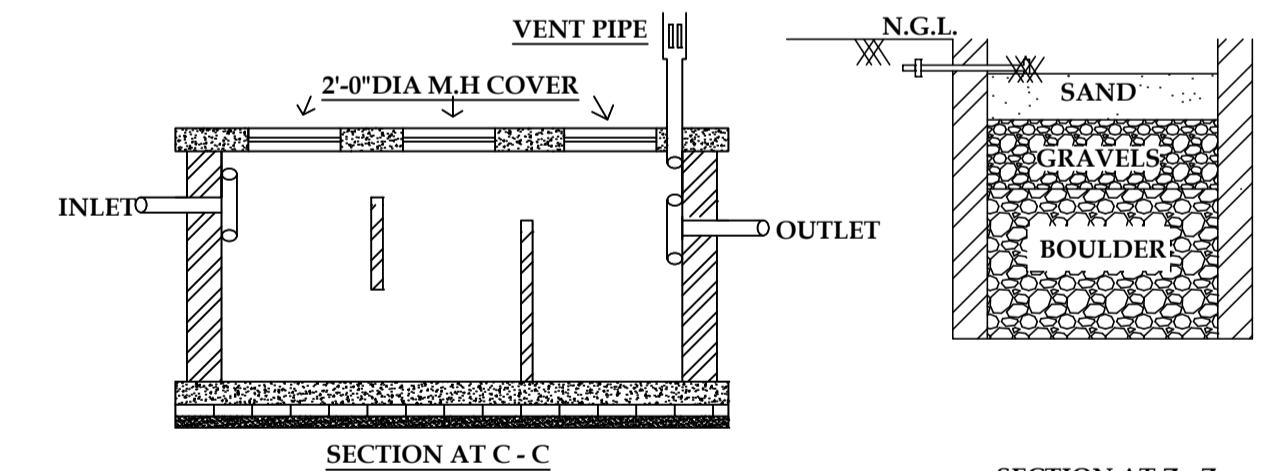

SECTION AT C - C

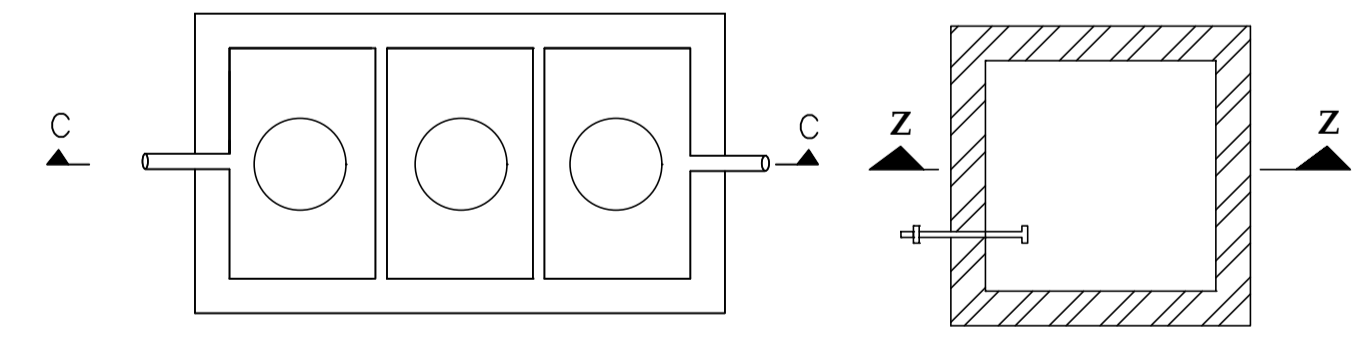

SECTION AT Z - Z

PLAN OF SEPTIC TANK (SCALE = 1:48)

R.W.H PLAN (SCALE = 1 : 48)

SCHEDULE OF DOOR:

BUILDING NAME	NAME	LENGTH	HEIGHT	NOS
NISHA SURIN (A BUILDING)	D1	0.74	2.10	01
NISHA SURIN (A BUILDING)	D1	0.76	2.10	05
NISHA SURIN (A BUILDING)	D	0.99	2.10	09
NISHA SURIN (A BUILDING)	D2	1.07	2.10	06

SCHEDULE OF WINDOW/VENTILATION:

BUILDING NAME	NAME	LENGTH	HEIGHT	NOS
NISHA SURIN (A BUILDING)	V	0.60	1.20	06
NISHA SURIN (A BUILDING)	W1	1.52	1.20	02
NISHA SURIN (A BUILDING)	W	1.83	1.20	10
NISHA SURIN (A BUILDING)	W5	3.43	1.20	01

UnitBUA Table for Building :NISHA SURIN (A BUILDING)

FLOOR	Name	UnitBUA Type	UnitBUA Area	Carpet Area	No. of Rooms	No. of Tenement
GROUND FLOOR PLAN	SPLIT A	FLAT	208.27	208.18	11	1
FIRST FLOOR PLAN	SPLIT A	FLAT	0.00	0.00	10	0
Total:	-	-	208.27	208.18	21	1

Balcony Calculations Table

FLOOR	SIZE	AREA	TOTAL AREA
FIRST FLOOR PLAN	1.20 X 4.17 X 1 X 1	4.99	4.99
Total	-	-	4.99

Building :NISHA SURIN (A BUILDING)

Floor Name	Total Built Up Area (Sq.mt.)	Deductions (Area in Sq.mt.)	Proposed FAR Area (Sq.mt.)	Total FAR Area (Sq.mt.)	Total Consumed Additional FAR Area (Sq.mt.)	Trmt (No.)
Ground Floor	129.96	0.00	129.96	129.96	129.96	01
First Floor	124.09	2.49	121.60	121.60	121.60	00
Terrace Floor	0.00	0.00	0.00	0.00	0.00	00
Total :	254.05	2.49	251.56	251.56	251.56	01
Total Number of Same Buildings	1					
Total :	254.05	2.49	251.56	251.56	251.56	01

LTP NAME AND SIGNATURE	STRUCTURAL ENG'S NAME AND SIGNATURE	BUILDER NAME AND SIGNATURE	DIGITAL SIGNATURE
ITMOON TIRKEY SINPC/DFTMN/0003/2022			

Proposal Basic Information

Proposal File No.	SINPC/BP/0442/W16/2023
Owner Name	NISHA SURIN
Khata No	41
Plot No	1937
Village Name	Simdega
Use	Residential
SubUse	Bungalow/ Dwelling / Non Apartment

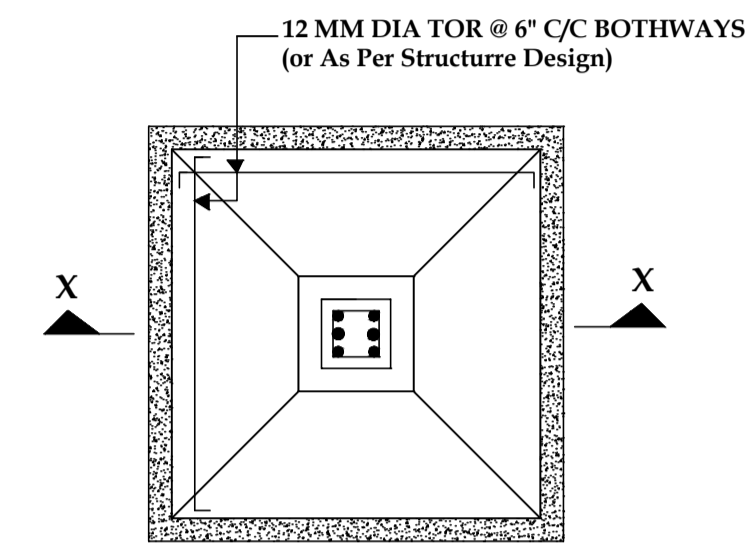

PLAN
DET. OF FOUNDATION
(SCALE - 1 : 24)

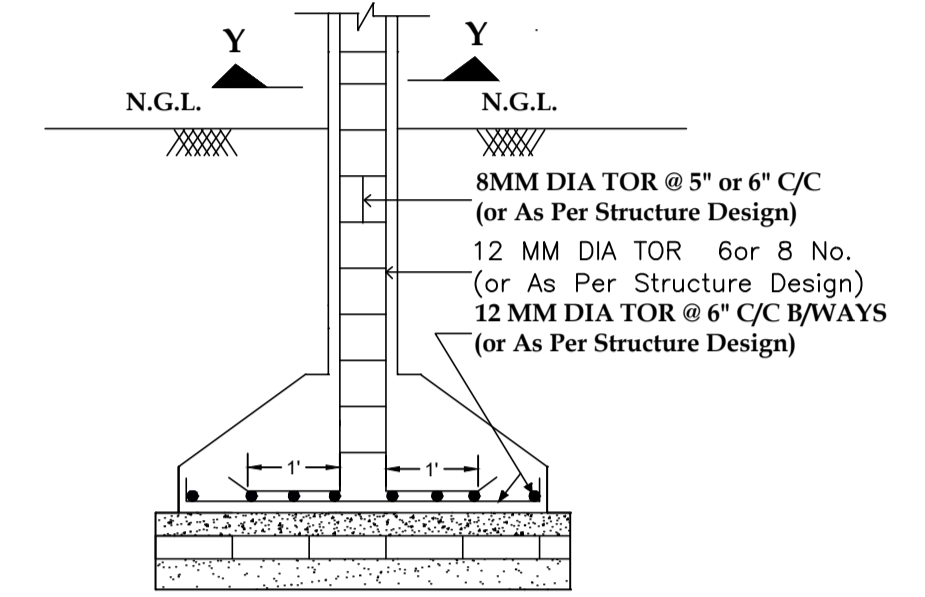

SECTION AT X - X
(SCALE - 1 : 24)

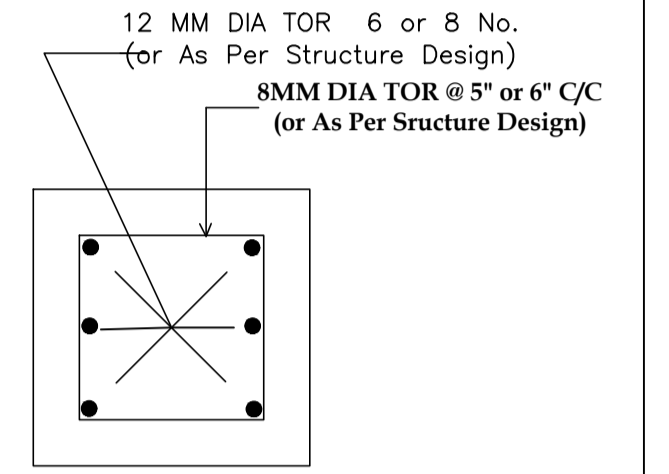

COLUMN
SECTION AT Y - Y
(NOT TO SCALE)

LTP NAME AND SIGNATURE	STRUCTURAL ENG'S NAME AND SIGNATURE	BUILDER NAME AND SIGNATURE	DIGITAL SIGNATURE
ITMOON TIRKEY SINPC/DFTMN/0003/2022			