

SITE PLAN

FAR & Tenement Details (Table 4c-1)

Building	No. of Same Bldg	Total Built Up Area (Sq.mt.)	Proposed FAR Area (Sq.mt.) Resi.	Total FAR Area (Sq.mt.)	Total Consumed Additional FAR Area (Sq.mt.)	Tnmt (No.)
A1 (RESIDENCE)	1	285.73	285.73	285.73	285.73	01
Grand Total	1	285.73	285.73	285.73	285.73	01

Proposal Basic Information

Proposal File No.	SINPC/BP/0378/W05/2023
Owner Name	SUDHA GUPTA
Khata No	108
Plot No	680
Village Name	Saldega
Use	Residential
SubUse	Bungalow/ Dwelling / Non Apartment

AREA STATEMENT SIMDEGA NAGAR PANCHAYAT		VERSION NO. : 1.0.66
PROJECT DETAIL:		VERSION DATE: 16/10/2020
Region: JHARKHAND URBAN LOCAL BODIES	Plot Use: Residential	
District: SIMDEGA	Plot SubUse: Bungalow/ Dwelling / Non Apartment	
Authority: SIMDEGA NAGAR PANCHAYAT	PlotNearbyReligiousStructure: NA	
Inward No: SINPC/BP/0378/W05/2023	PlotSubPlot No: 680	
Application Type: General Proposal	North: -	
Project Type: Building Permission	South: -	
Nature of Development: New	East: -	
Location of Development Area: Old Area	West: -	
AREA DETAILS:		
AREA OF PLOT (Minimum)	(A)	198.34
NET AREA OF PLOT(Gross Plot Area - Deduction from Gross Plot area)	(A-Deductions)	198.34
Deduction for Balance Plot Area(from Gross Plot Area)		
Common Plot		16.63
Total		16.63
BALANCE AREA OF PLOT(Net Plot Area - Recreational/Amenity space)	(A-Deductions)	181.71
PLOT AREA FOR COVERAGE(Net Plot Area)	(A-Deductions)	198.34
Plot Area for FAR (Net Plot Area + Road Widening Area)	(A-Deductions)	198.34
COVERAGE CHECK		
Permissible Coverage area (70.00 %)		138.84
Proposed Coverage Area (44.41 %)		88.09
Total Prop. Coverage Area (44.41 %)		88.09
Balance coverage area (25.59 %)		50.75
FAR CHECK		
Perm. FAR Area (2,000)		396.68
Total Perm. FAR area		396.68
Residential FAR		285.72
Proposed FAR Area		285.72
Total Proposed FAR Area		285.72
Consumed FAR (Factor)		1.44
Balance FAR Area		110.96
BUILT UP AREA CHECK		
Total Proposed BuiltUp Area		285.73
ARCHITECT (Regd)	MAHENDRA MEHTA	
ENGINEER (Regd)		
SUPERVISOR (Regd)		
OWNER (Regd)	SUDHA GUPTA	
DEVELOPMENT AUTHORITY		LOCAL BODY

COLOR INDEX	
PLOT BOUNDARY	Black
ABUTTING ROAD	Green
PROPOSED CONSTRUCTION	Red
COMMON PLOT	Yellow
ROAD WIDENING AREA	Orange
EXISTING (To be retained)	Blue
EXISTING (To be demolished)	Light Blue

Buildingwise Floor FAR Details

Floor Name	Building Name A1 (RESIDENCE)		Total	
	Proposed Built Up Area (Sq.mt.)	Proposed FAR Area (Sq.mt.)	Total Proposed Built Up Area (Sq.mt.)	Total FAR Area (Sq.mt.)
Ground Floor	88.09	88.09	88.09	88.09
First Floor	98.82	98.82	98.82	98.82
Second Floor	98.82	98.82	98.82	98.82
Terrace Floor	0.00	0.00	0.00	0.00
Total	285.73	285.73	285.73	285.73

Building USE/SUBUSE Details

Building Name	Building Use	Building SubUse	Building Structure
A1 (RESIDENCE)	Residential	Bungalow/ Dwelling / Non Apartment	Non-Highrise

LTP NAME AND SIGNATURE	STRUCTURAL ENG'S NAME AND SIGNATURE	BUILDER NAME AND SIGNATURE	DIGITAL SIGNATURE
MAHENDRA MEHTA SINPC/DFTMN/0002/2022			

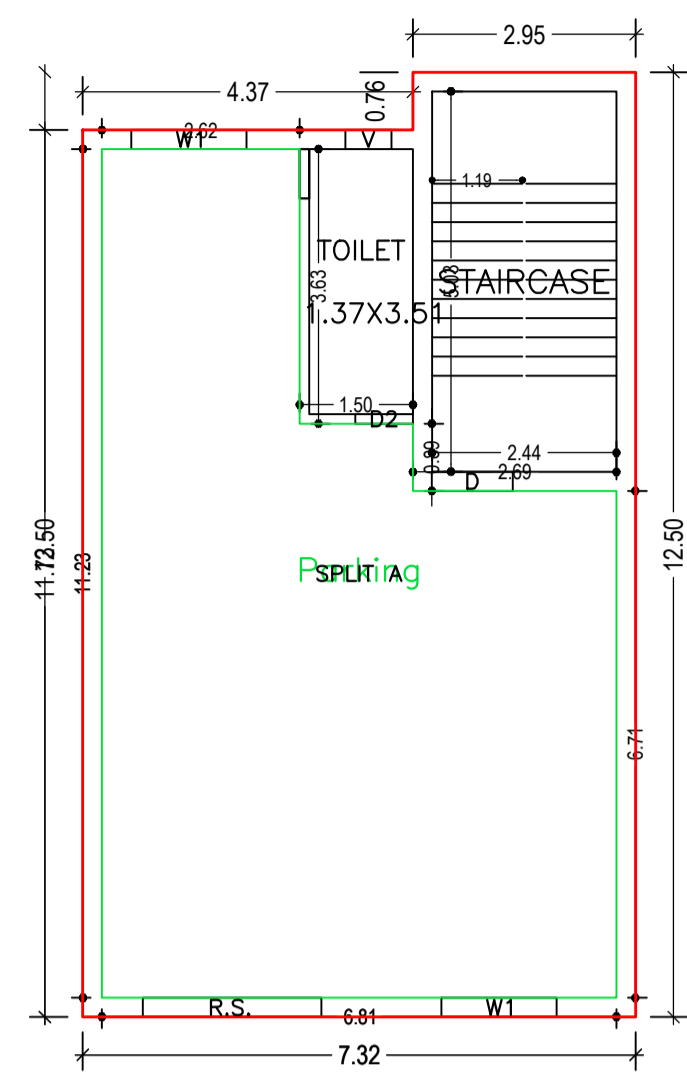

GROUND FLOOR PLAN (Proposed) (SCALE 1:100)

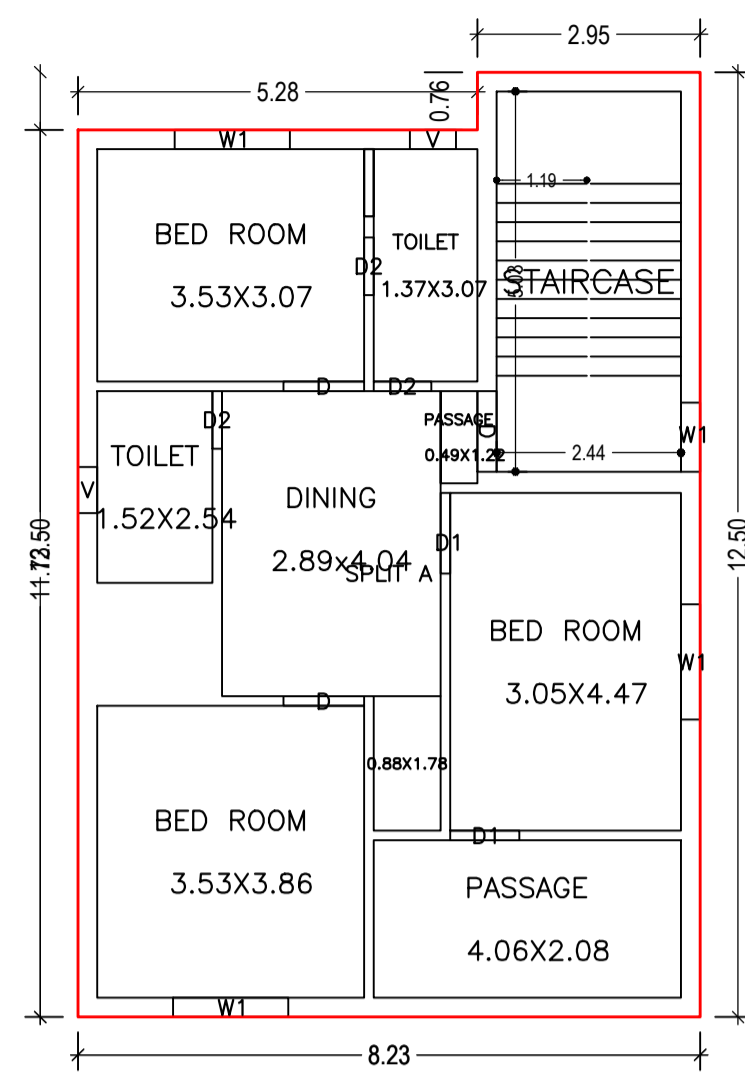

SECOND FLOOR PLAN (Proposed) (SCALE 1:100)

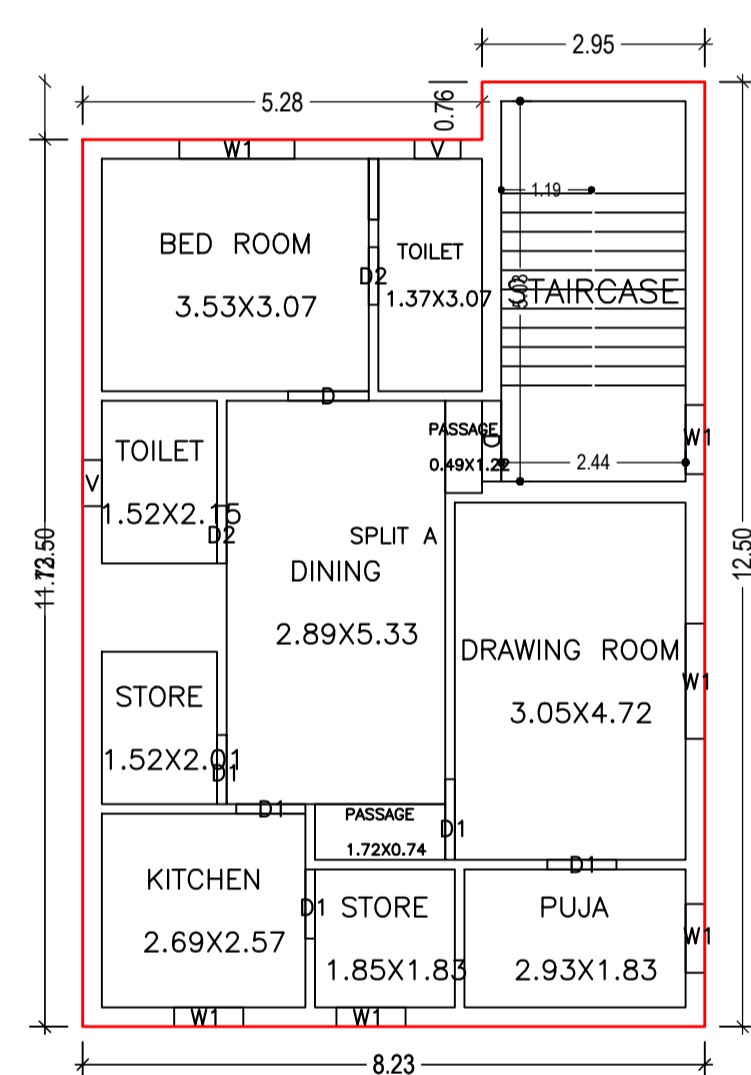

FIRST FLOOR PLAN (Proposed) (SCALE 1:100)

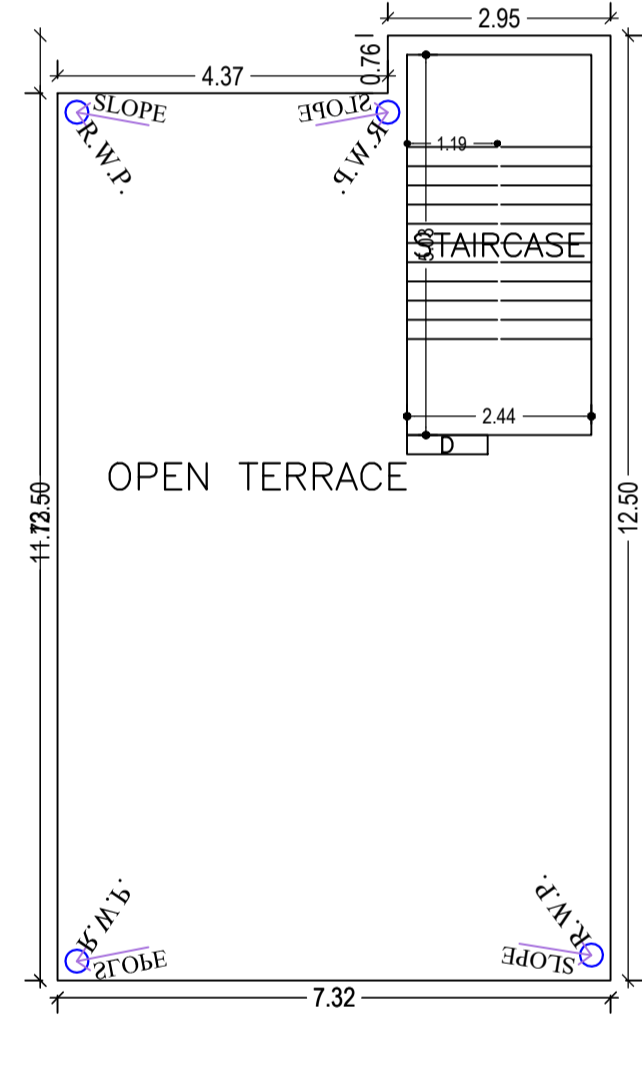

TERRACE FLOOR PLAN (SCALE 1:100)

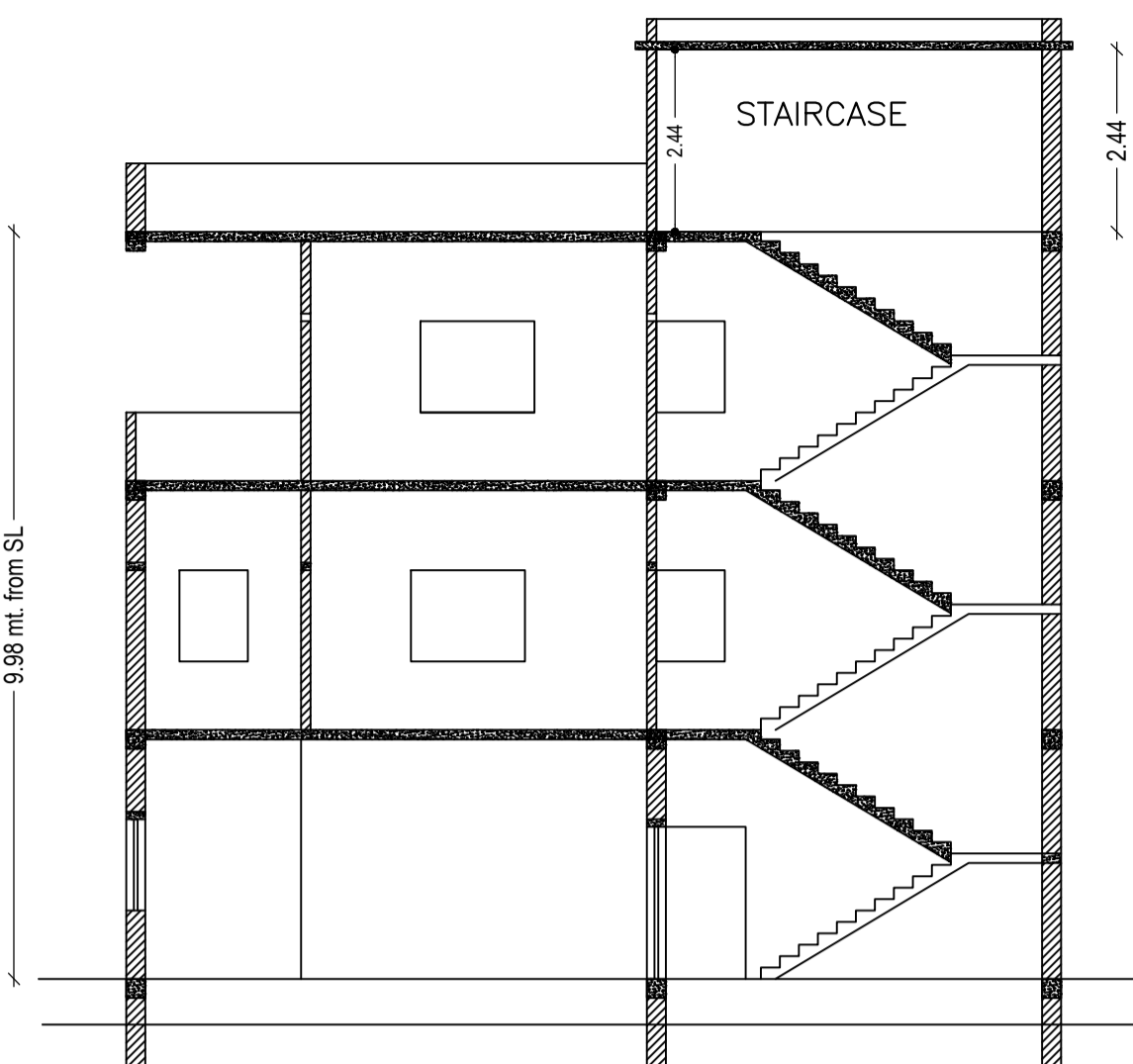

SECTION ON (SCALE 1:100)

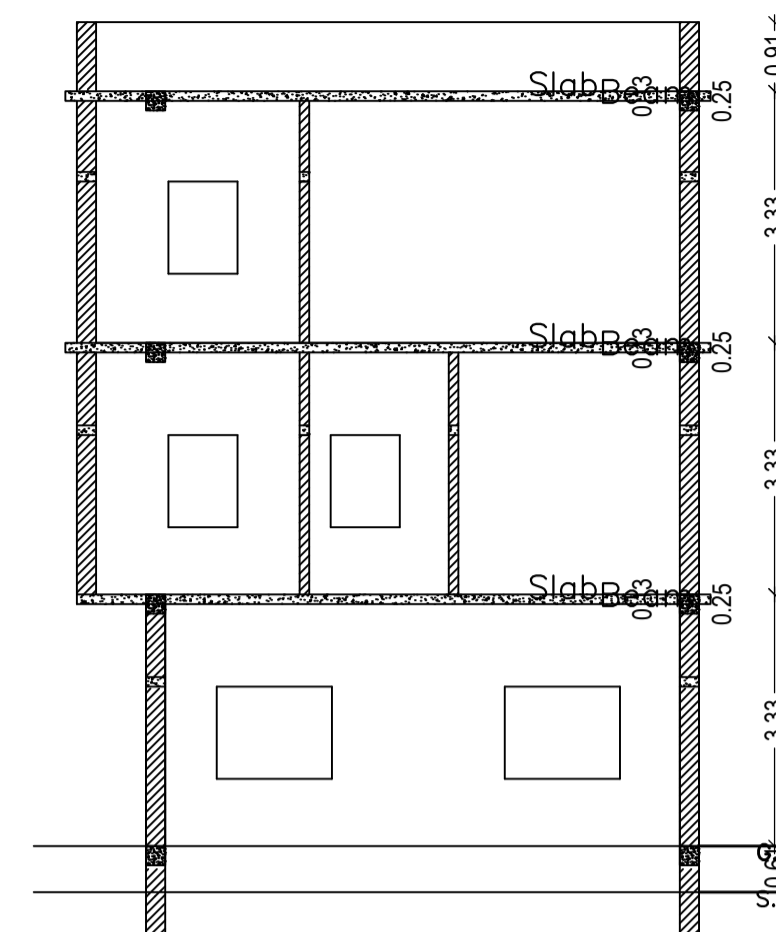

SECTION ON (SCALE 1:100)

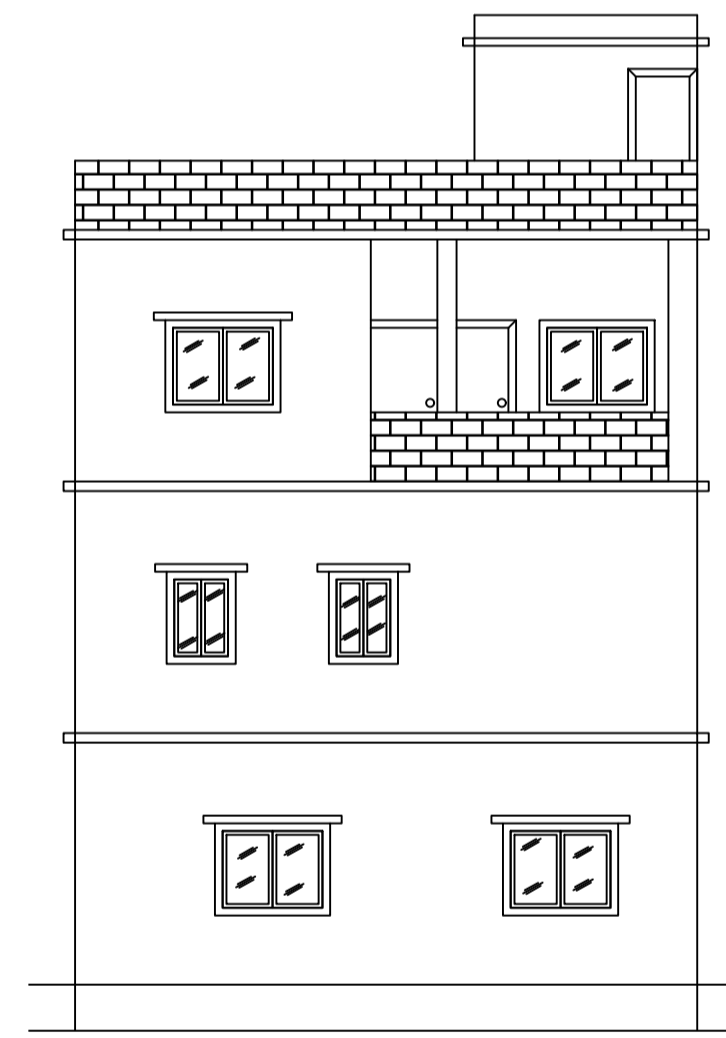

FRONT ELEVATION (SCALE 1:100)

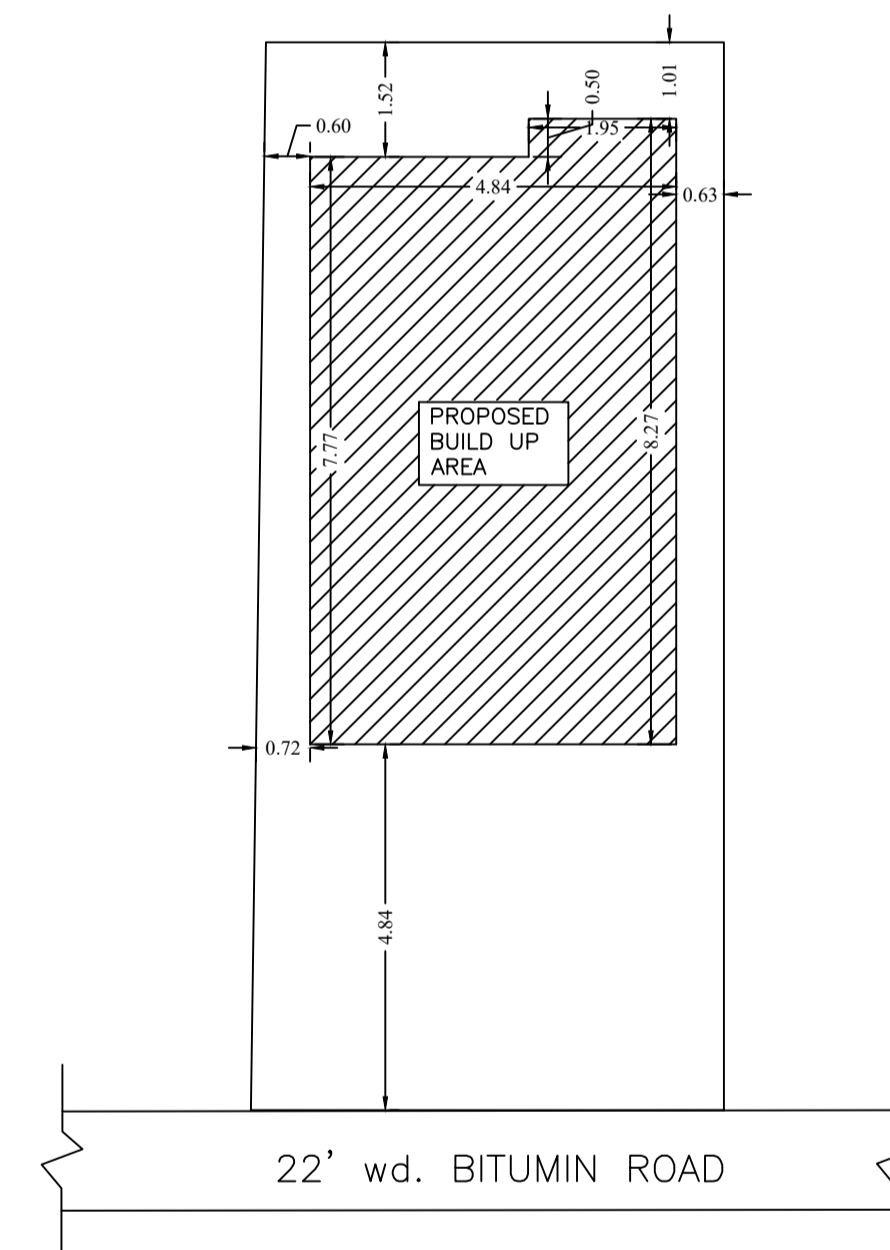

KEY PLAN (SCALE 1:200)

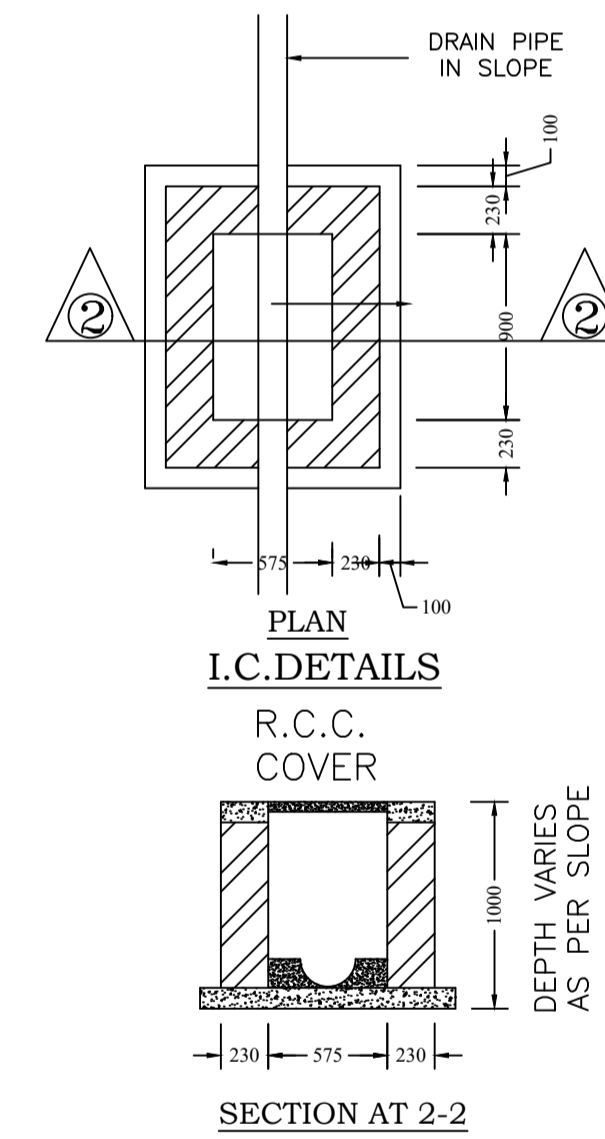

SECTION AT 2-2

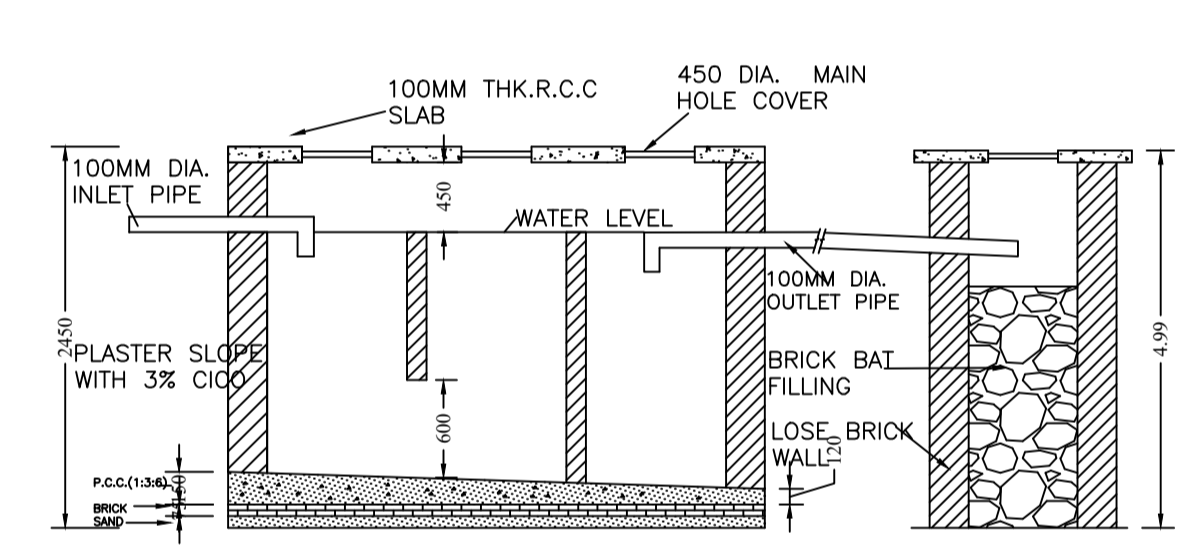

SECTION-DD

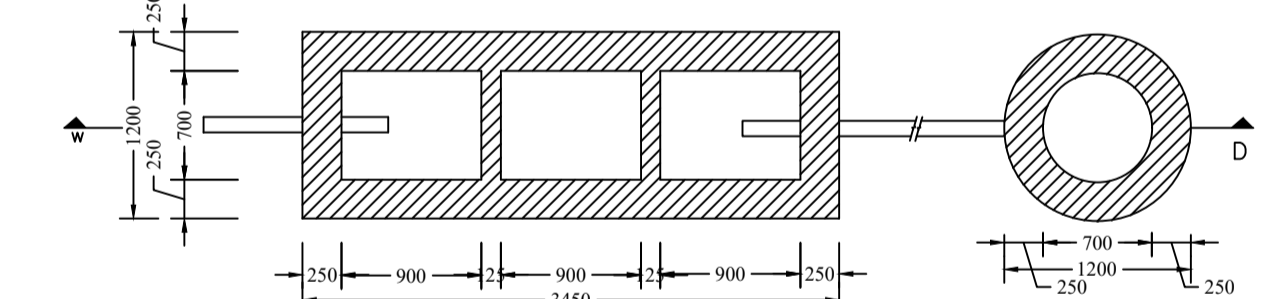

DETAIL OF SEPTIC TANK & SOAKPIT (SCALE 1:50)

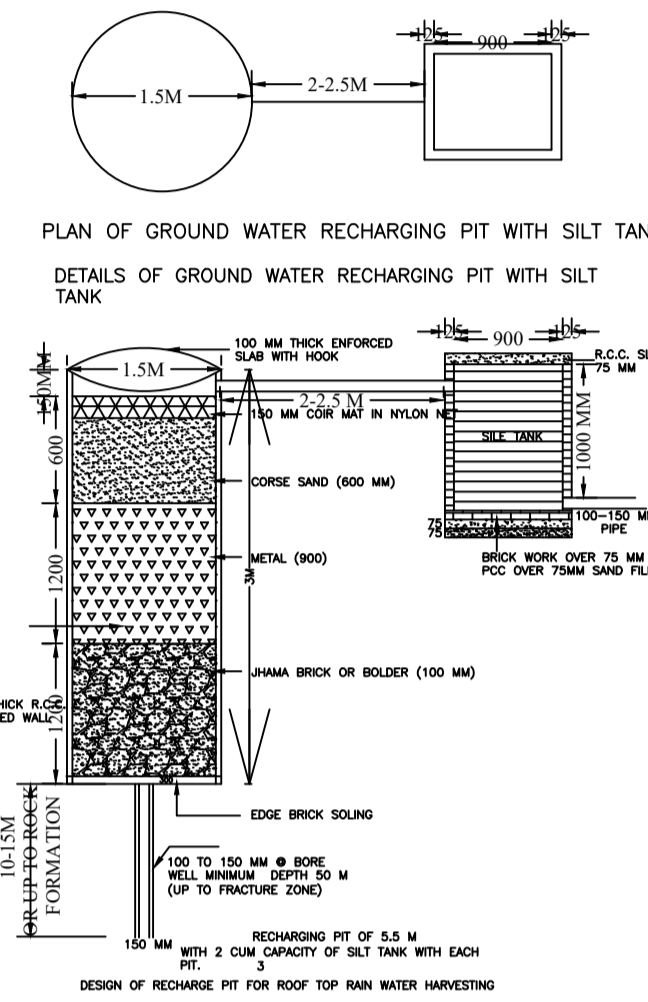

PLAN OF GROUND WATER RECHARGING PIT WITH SILT TANK

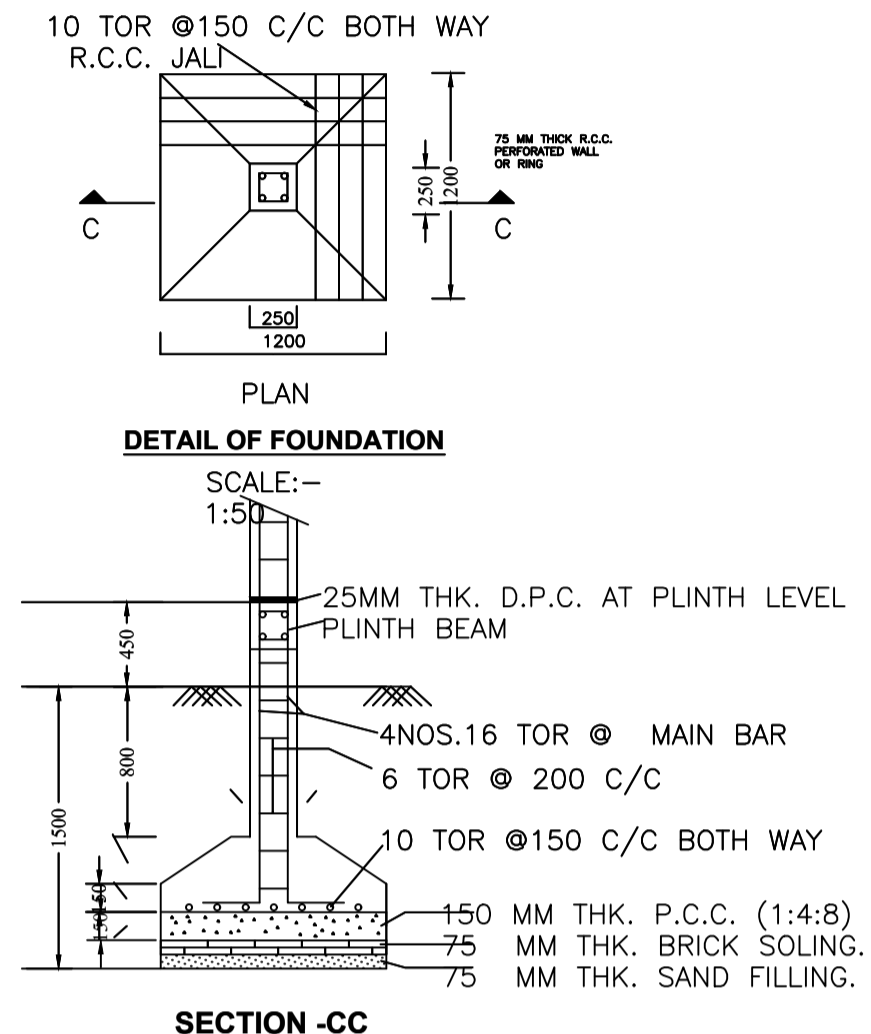

DETAIL OF FOUNDATION (SCALE 1:50)

Building :A1 (RESIDENCE)

Floor Name	Total Built Up Area (Sq.mt.)	Proposed FAR Area (Sq.mt.) Resi.	Total FAR Area (Sq.mt.)	Total Consumed Additional FAR Area (Sq.mt.)	Tnmt (No.)
Ground Floor	88.09	88.09	88.09	88.09	01
First Floor	98.82	98.82	98.82	98.82	00
Second Floor	98.82	98.82	98.82	98.82	00
Terrace Floor	0.00	0.00	0.00	0.00	00
Total:	285.73	285.73	285.73	285.73	01
Total Number of Same Buildings	1				
Total:	285.73	285.73	285.73	285.73	01

SCHEDULE OF DOOR:

BUILDING NAME	NAME	LENGTH	HEIGHT	NOS
A1 (RESIDENCE)	D2	0.76	2.10	06
A1 (RESIDENCE)	D1	0.91	2.10	05
A1 (RESIDENCE)	D	1.07	2.10	05
A1 (RESIDENCE)	D1	1.07	2.10	02

SCHEDULE OF WINDOW/VENTILATION:

BUILDING NAME	NAME	LENGTH	HEIGHT	NOS
A1 (RESIDENCE)	V	0.61	1.20	05
A1 (RESIDENCE)	W1	0.91	1.20	05
A1 (RESIDENCE)	W1	1.52	1.20	05

UnitBUA Table for Building :A1 (RESIDENCE)

FLOOR	Name	UnitBUA Type	UnitBUA Area	Carpet Area	No. of Rooms	No. of Tenement
GROUND FLOOR PLAN	SPLIT A	FLAT	211.21	210.91	1	1
FIRST FLOOR PLAN	SPLIT A	FLAT	0.00	0.00	11	0
SECOND FLOOR PLAN	SPLIT A	FLAT	0.00	0.00	8	0
Total:	-	-	211.21	210.91	20	1

LTP NAME AND SIGNATURE	STRUCTURAL ENG'S NAME AND SIGNATURE	BUILDER NAME AND SIGNATURE	DIGITAL SIGNATURE
MAHENDRA MEHTA SINPC/DFTMN/0002/2022			

Proposal Basic Information

Proposal File No.	SINPC/BP/0378/W05/2023
Owner Name	SUDHA GUPTA
Khata No	108
Plot No	680
Village Name	Saldega
Use	Residential
SubUse	Bungalow/ Dwelling / Non Apartment

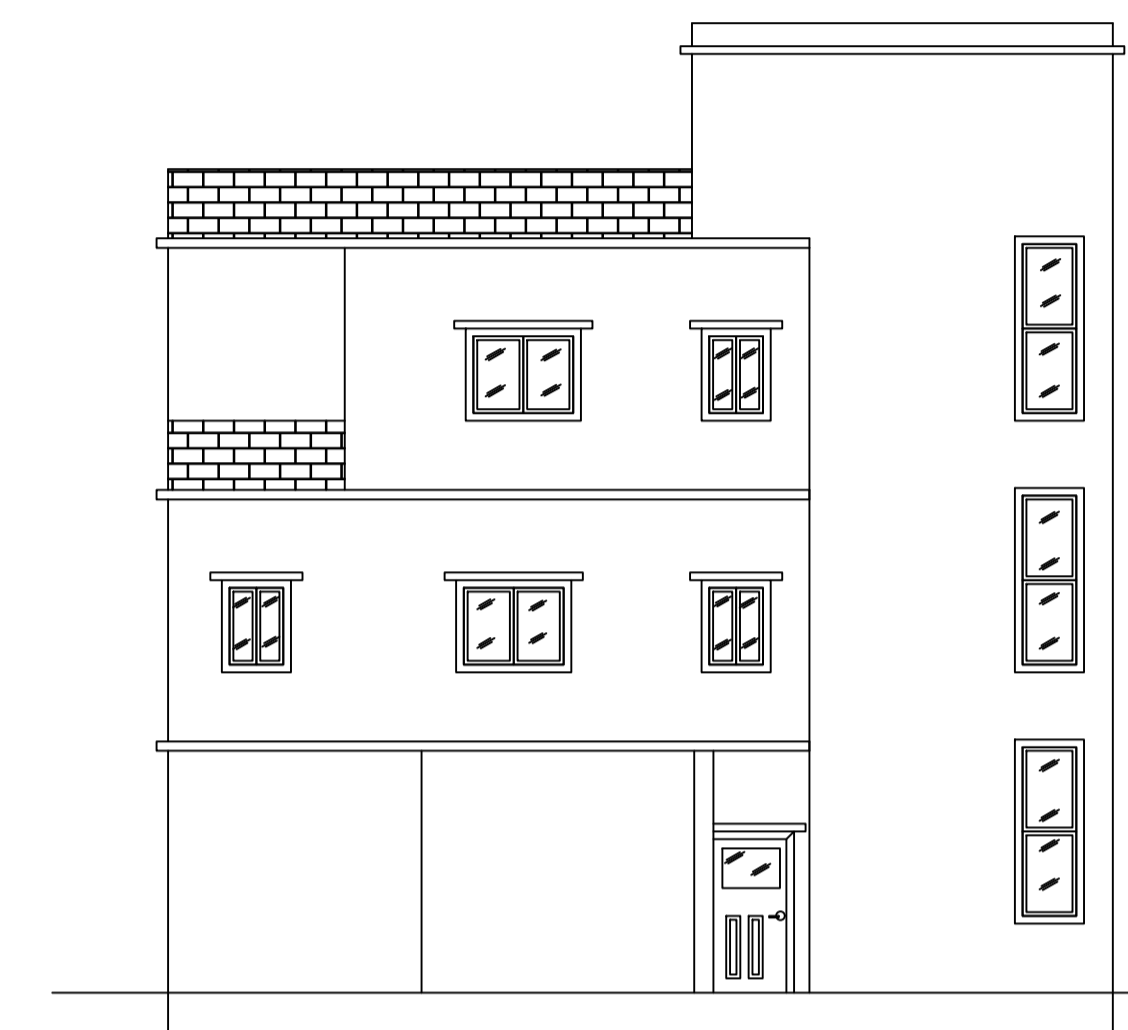

RIGHT SIDE ELEVATION
SCALE: 1:100

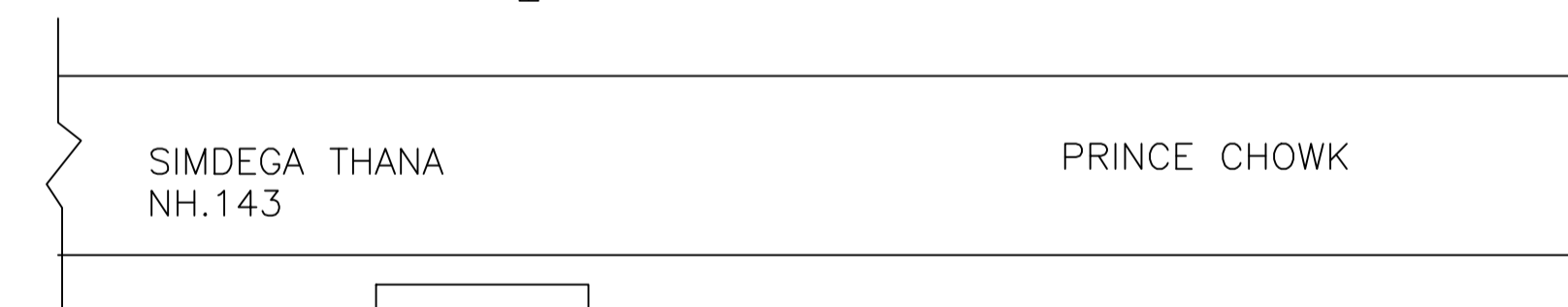
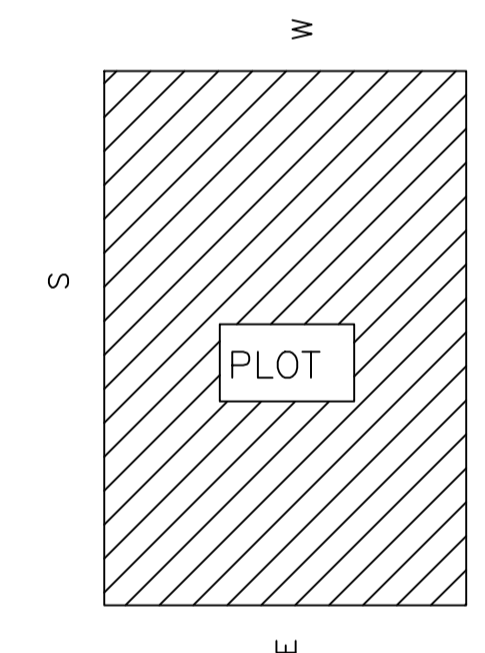

LOCATION PLAN
NOT IN SCALE

LTP NAME AND SIGNATURE	STRUCTURAL ENG'S NAME AND SIGNATURE	BUILDER NAME AND SIGNATURE	DIGITAL SIGNATURE
MAHENDRA MEHTA SINPC/DFTMN/0002/2022			