

SITE PLAN

FAR & Tenement Details (Table 4c-1)

Building	No. of Same Bldg	Total Built Up Area (Sq.mt.)	Proposed FAR Area (Sq.mt.) Resi.	Total FAR Area (Sq.mt.)	Total Consumed Additional FAR Area (Sq.mt.)	Tnmt (No.)
A1 (RESIDENCE)	1	361.86	361.86	361.86	361.86	01
Grand Total	1	361.86	361.86	361.86	361.86	01

Proposal Basic Information

Proposal File No.	SINPC/BP/0379/W02/2023
Owner Name	WILSON KERKETTA
Khata No	120
Plot No	4988
Village Name	Gotra
Use	Residential
SubUse	Bungalow/ Dwelling / Non Apartment

AREA STATEMENT SIMDEGA NAGAR PANCHAYAT		VERSION NO.: 1.0.66
PROJECT DETAIL:		VERSION DATE: 16/10/2020
Region: JHARKHAND URBAN LOCAL BODIES	Plot Use: Residential	
District: SIMDEGA	Plot SubUse: Bungalow/ Dwelling / Non Apartment	
Authority: SIMDEGA NAGAR PANCHAYAT	PlotNearbyReligiousStructure: NA	
Inward No: SINPC/BP/0379/W02/2023	Plot/SubPlot No: 4988	
Application Type: General Proposal	North: -	
Project Type: Building Permission	South: -	
Nature of Development: New	East: -	
Location of Development Area: Old Area	West: -	
AREA DETAILS:		
AREA OF PLOT (Minimum)	(A)	SQ.MT. 438.43
Deduction for NetPlot Area		
Surrender Free of Cost		31.61
Total		31.61
NET AREA OF PLOT(Gross Plot Area - Deduction from Gross Plot area)		
(A-Deductions)		406.82
Deduction for Balance Plot Area(from Gross Plot Area)		
Surrender Free of Cost		31.61
Common Plot		22.01
Total		53.62
BALANCE AREA OF PLOT(Net Plot Area - Recreational/Amenity space)		
(A-Deductions)		384.81
PLOT AREA FOR COVERAGE(Net Plot Area)		
(A-Deductions)		406.82
Plot Area for FAR (Net Plot Area + RoadWidening Area)		
(A-Deductions)		438.43
COVERAGE CHECK		
Permissible Coverage area (60.00 %)		244.09
Proposed Coverage Area (44.47 %)		180.93
Total Prop. Coverage Area (44.47 %)		180.93
Balance coverage area (15.53 %)		63.16
FAR CHECK		
Perm. FAR Area (1.500)		657.65
Total Perm. FAR area		657.65
Residential FAR		361.85
Proposed FAR Area		361.85
Total Proposed FAR Area		361.85
Consumed FAR (Factor)		0.83
Balance FAR Area		295.80
BUILT UP AREA CHECK		
Total Proposed BuiltUp Area		361.86
ARCHITECT (Regd)	MAHENDRA MEHTA	
ENGINEER (Regd)		
SUPERVISOR (Regd)		
OWNER (Regd)	WILSON KERKETTA	
DEVELOPMENT AUTHORITY		LOCAL BODY

COLOR INDEX	
PLOT BOUNDARY	Black
ABUTTING ROAD	Green
PROPOSED CONSTRUCTION	Red
COMMON PLOT	Yellow
ROAD WIDENING AREA	Orange
EXISTING (To be retained)	Blue
EXISTING (To be demolished)	Light Blue

Buildingwise Floor FAR Details

Floor Name	Building Name A1 (RESIDENCE)		Total	
	Proposed Built Up Area (Sq.mt.)	Proposed FAR Area (Sq.mt.)	Total Proposed Built Up Area (Sq.mt.)	Total FAR Area (Sq.mt.)
Ground Floor	180.93	180.93	180.93	180.93
First Floor	180.93	180.93	180.93	180.93
Terrace Floor	0.00	0.00	0.00	0.00
Total	361.86	361.86	361.86	361.86

Building USE/SUBUSE Details

Building Name	Building Use	Building SubUse	Building Structure
A1 (RESIDENCE)	Residential	Bungalow/ Dwelling / Non Apartment	Non-Highrise

LTP NAME AND SIGNATURE	STRUCTURAL ENG'S NAME AND SIGNATURE	BUILDER NAME AND SIGNATURE	DIGITAL SIGNATURE
MAHENDRA MEHTA SINPC/DFTMN/0002/2022			

Proposal Basic Information	
Proposal File No.	SINPC/BP/0379/W02/2023
Owner Name	WILSON KERKETTA
Khata No	120
Plot No	4988
Village Name	Gotra
Use	Residential
SubUse	Bungalow/ Dwelling / Non Apartment

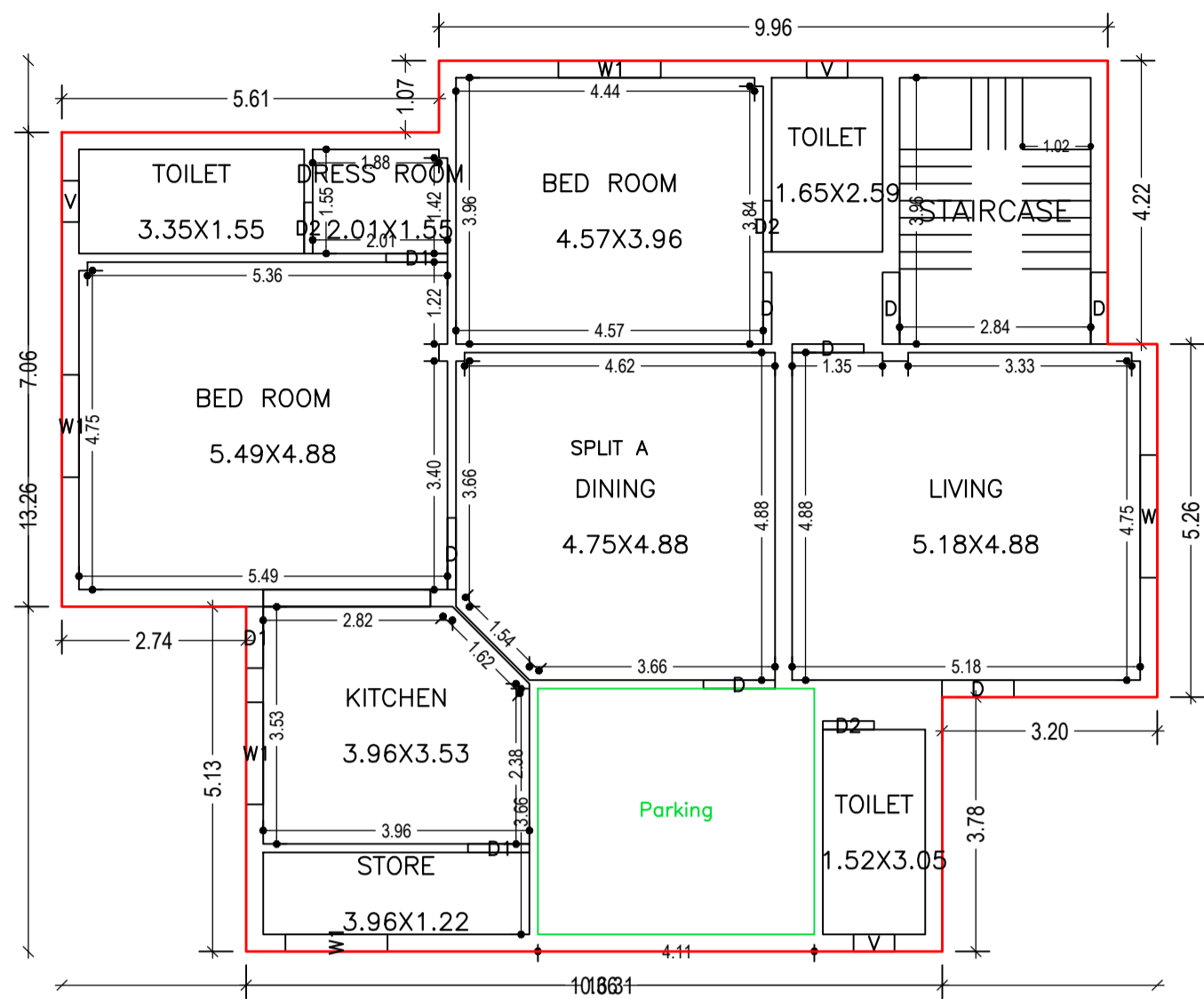

GROUND FLOOR PLAN (Proposed) (SCALE 1:100)

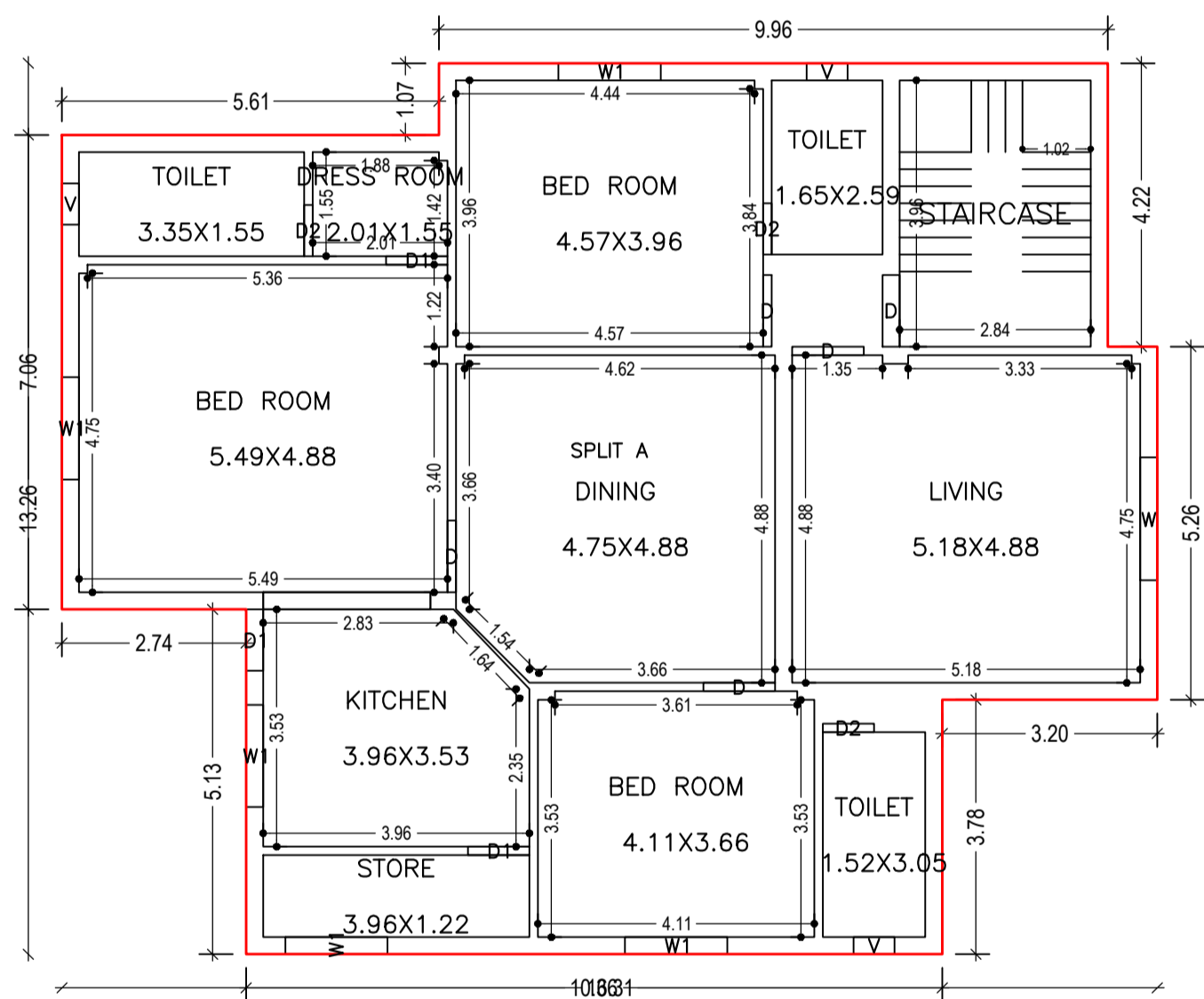

FIRST FLOOR PLAN (Proposed) (SCALE 1:100)

Building :A1 (RESIDENCE)

Floor Name	Total Built Up Area (Sq.mt.)	Proposed FAR Area (Sq.mt.) Resi.	Total FAR Area (Sq.mt.)	Total Consumed Additional FAR Area (Sq.mt.)	Tnmt (No.)
Ground Floor	180.93	180.93	180.93	180.93	01
First Floor	180.93	180.93	180.93	180.93	00
Terrace Floor	0.00	0.00	0.00	0.00	00
Total:	361.86	361.86	361.86	361.86	01
Total Number of Same Buildings	1				
Total:	361.86	361.86	361.86	361.86	01

SCHEDULE OF DOOR:

BUILDING NAME	NAME	LENGTH	HEIGHT	NOS
A1 (RESIDENCE)	D2	0.76	2.10	06
A1 (RESIDENCE)	D1	0.91	2.10	06
A1 (RESIDENCE)	D	1.07	2.10	09

SCHEDULE OF WINDOW/VENTILATION:

BUILDING NAME	NAME	LENGTH	HEIGHT	NOS
A1 (RESIDENCE)	V	0.61	1.20	06
A1 (RESIDENCE)	W1	1.52	1.20	09
A1 (RESIDENCE)	W	1.83	1.20	02

UnitBUA Table for Building :A1 (RESIDENCE)

FLOOR	Name	UnitBUA Type	UnitBUA Area	Carpet Area	No. of Rooms	No. of Tenement
GROUND FLOOR PLAN	SPLIT A	FLAT	307.05	305.78	10	1
FIRST FLOOR PLAN	SPLIT A	FLAT	0.00	0.00	11	0
Total:	-	-	307.05	305.78	21	1

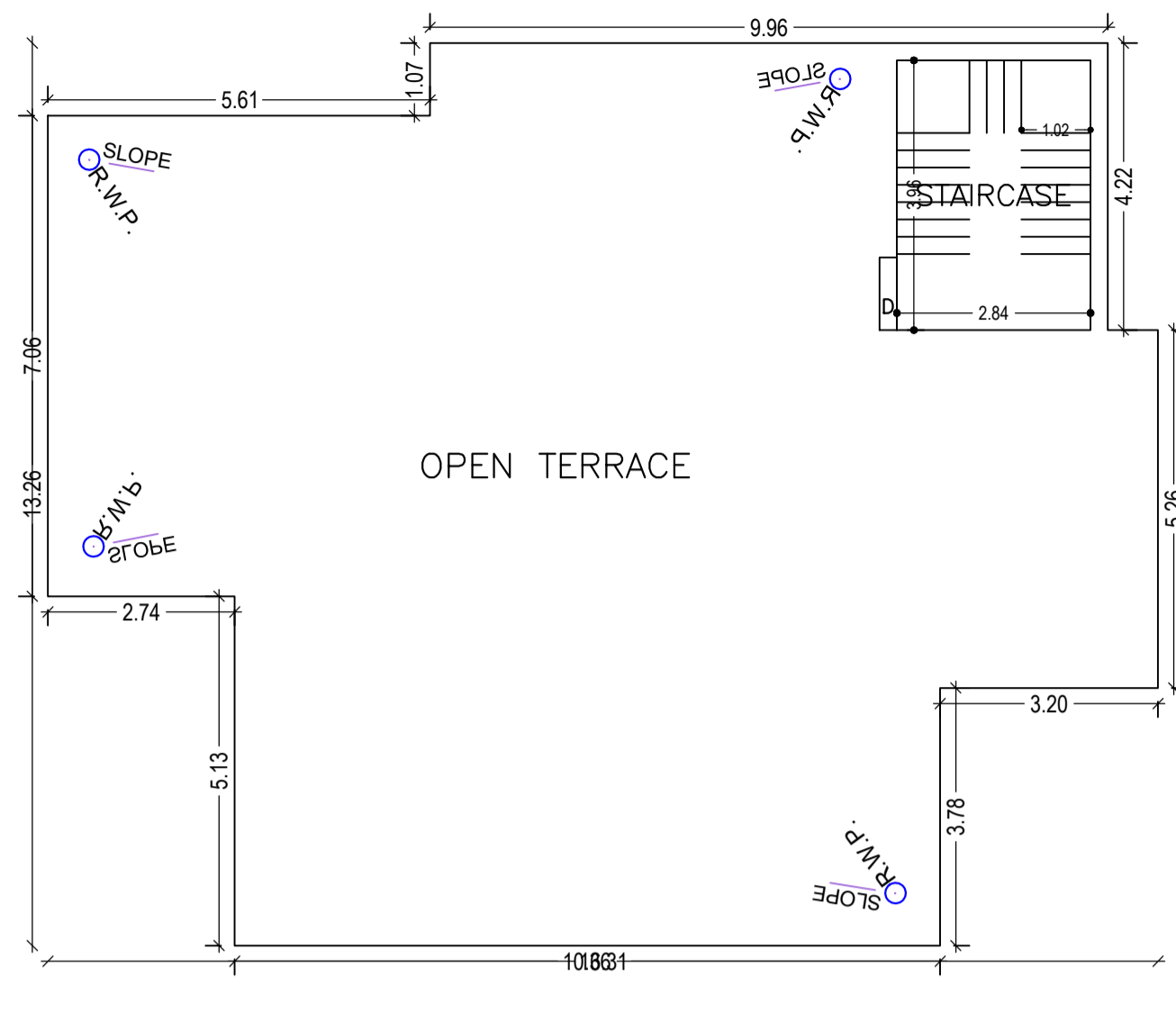

TERRACE FLOOR PLAN (SCALE 1:100)

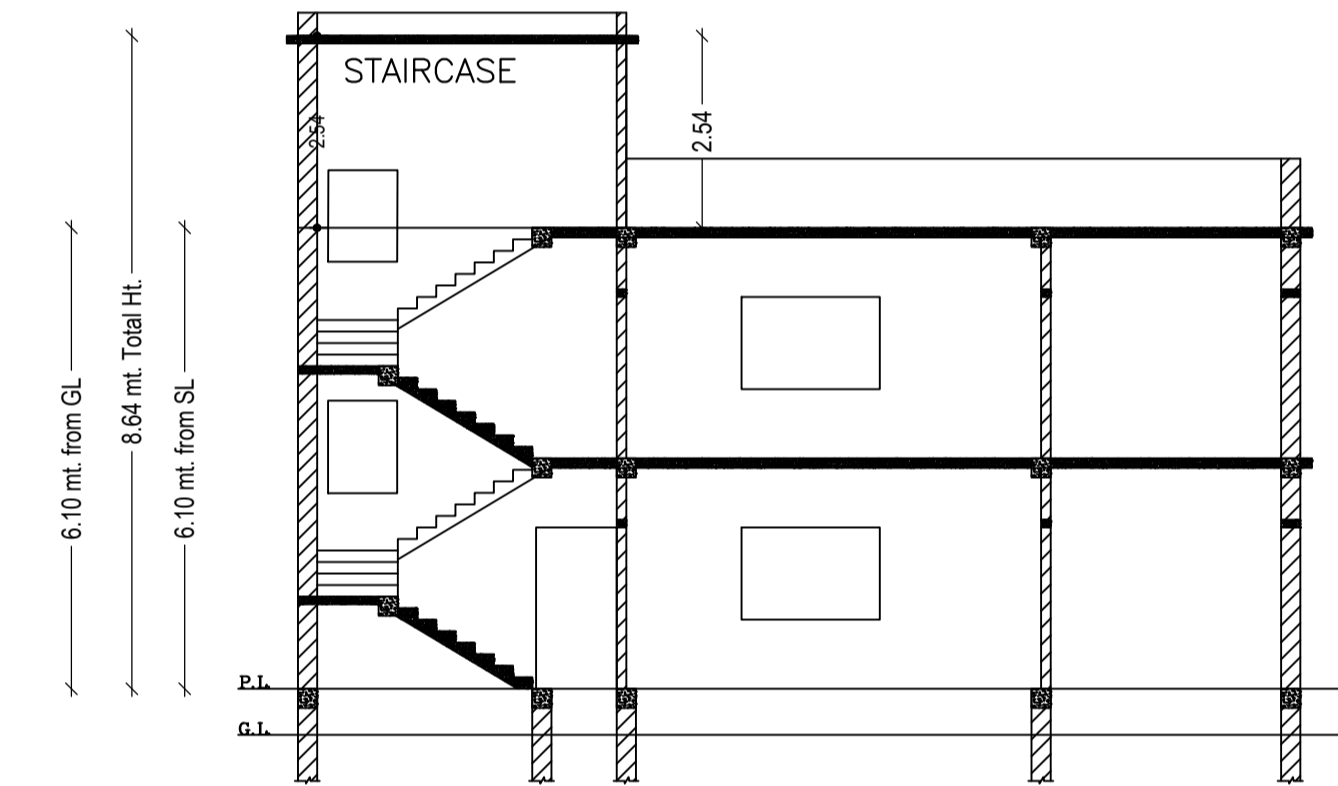

SECTION ON (SCALE 1:100)

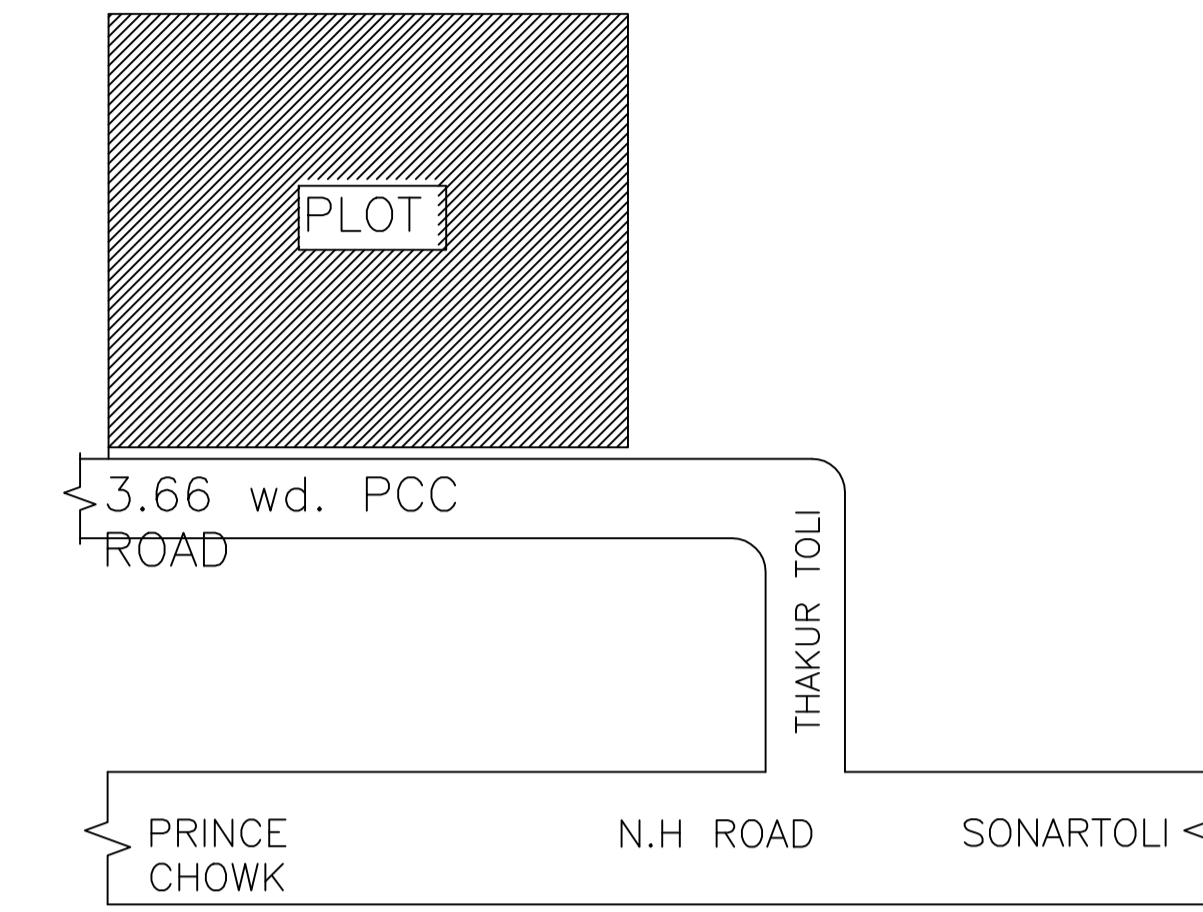

LOCATION PLAN (NOT IN SCALE)

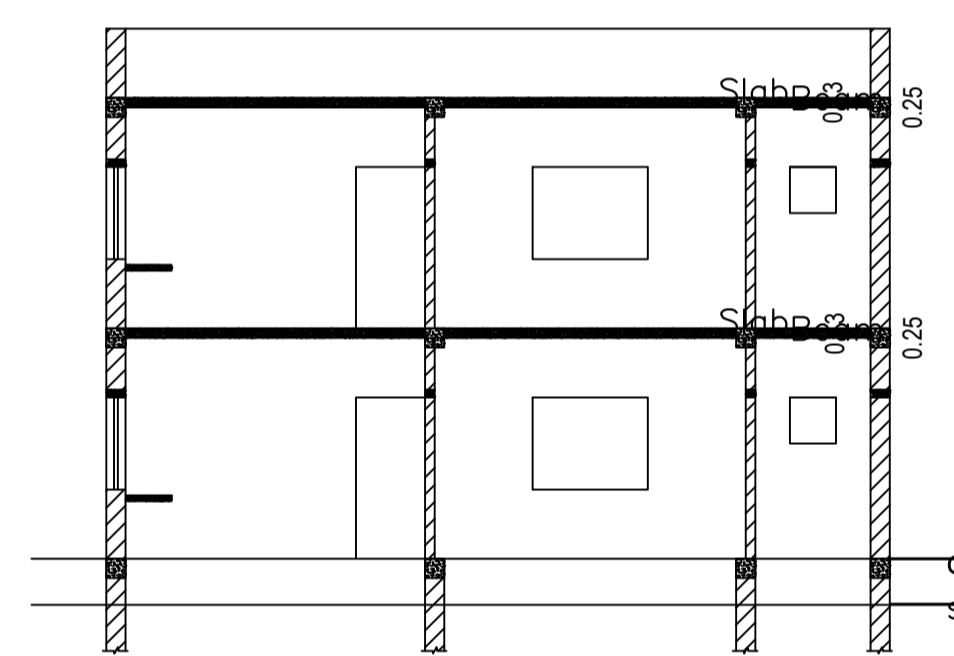

SECTION ON (SCALE 1:100)

10 TOR @150 C/C BOTH WAY
R.C.C. JALI

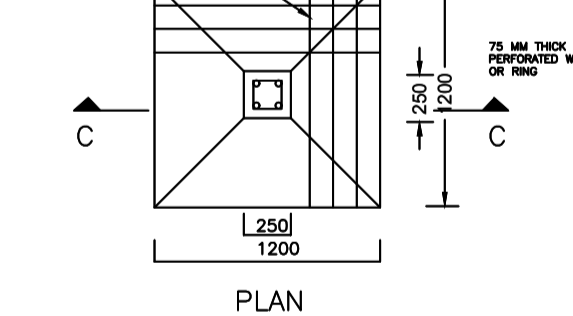

DETAIL OF FOUNDATION

SCALE:- 1:50

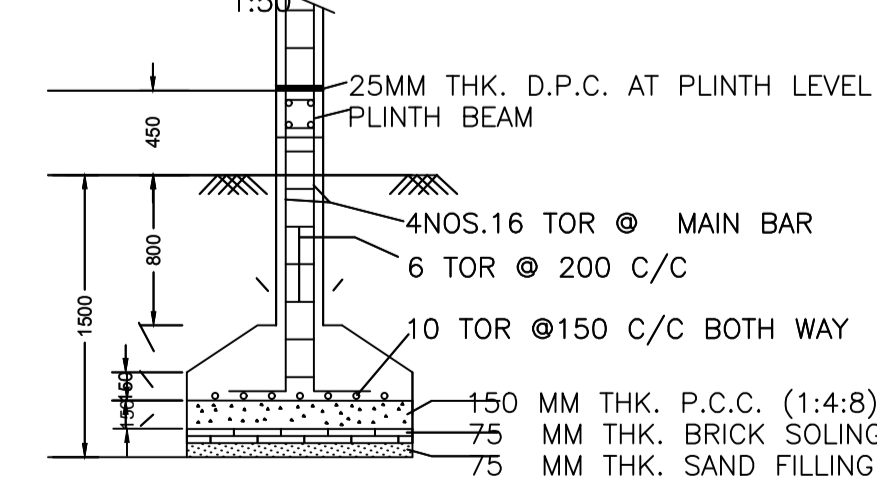

SECTION -CC

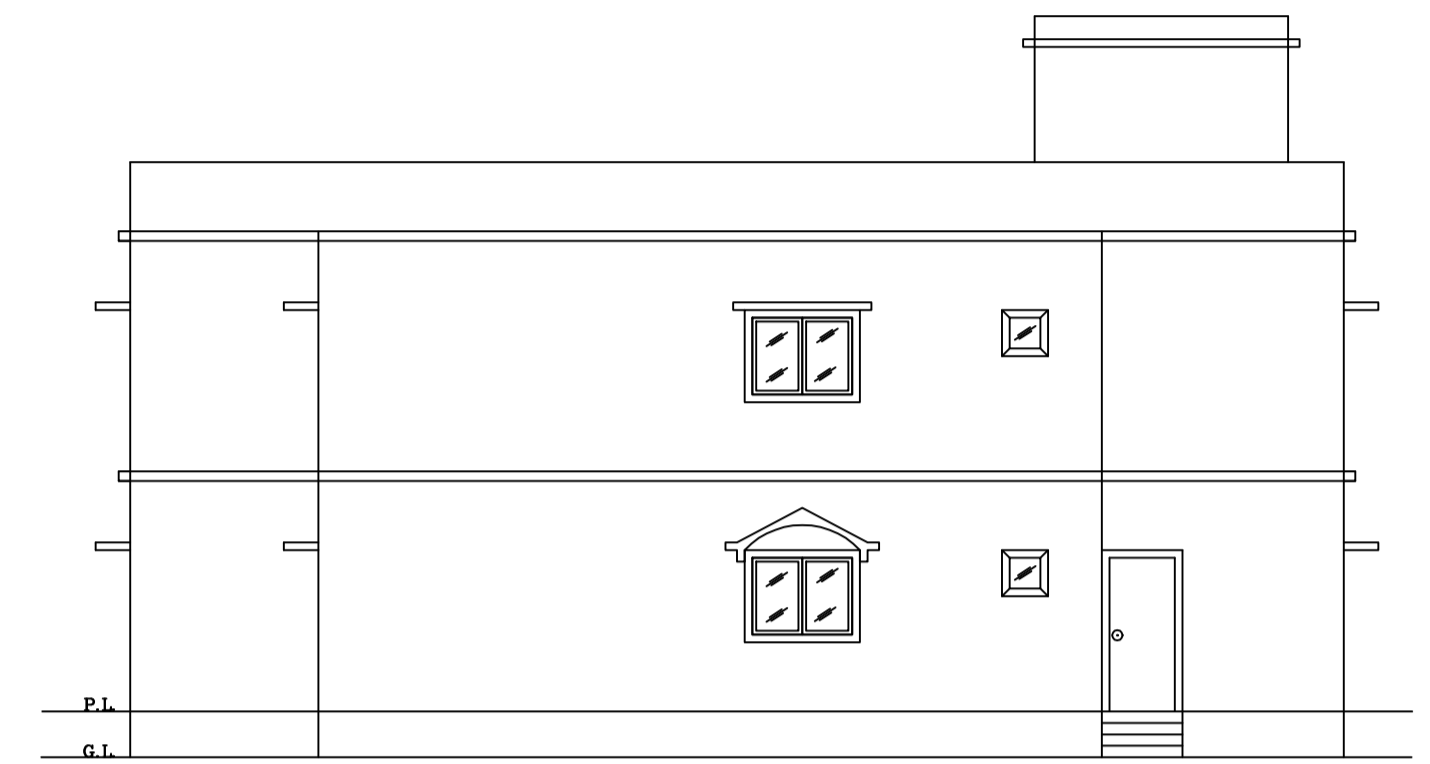

FRONT ELEVATION (SCALE 1:100)

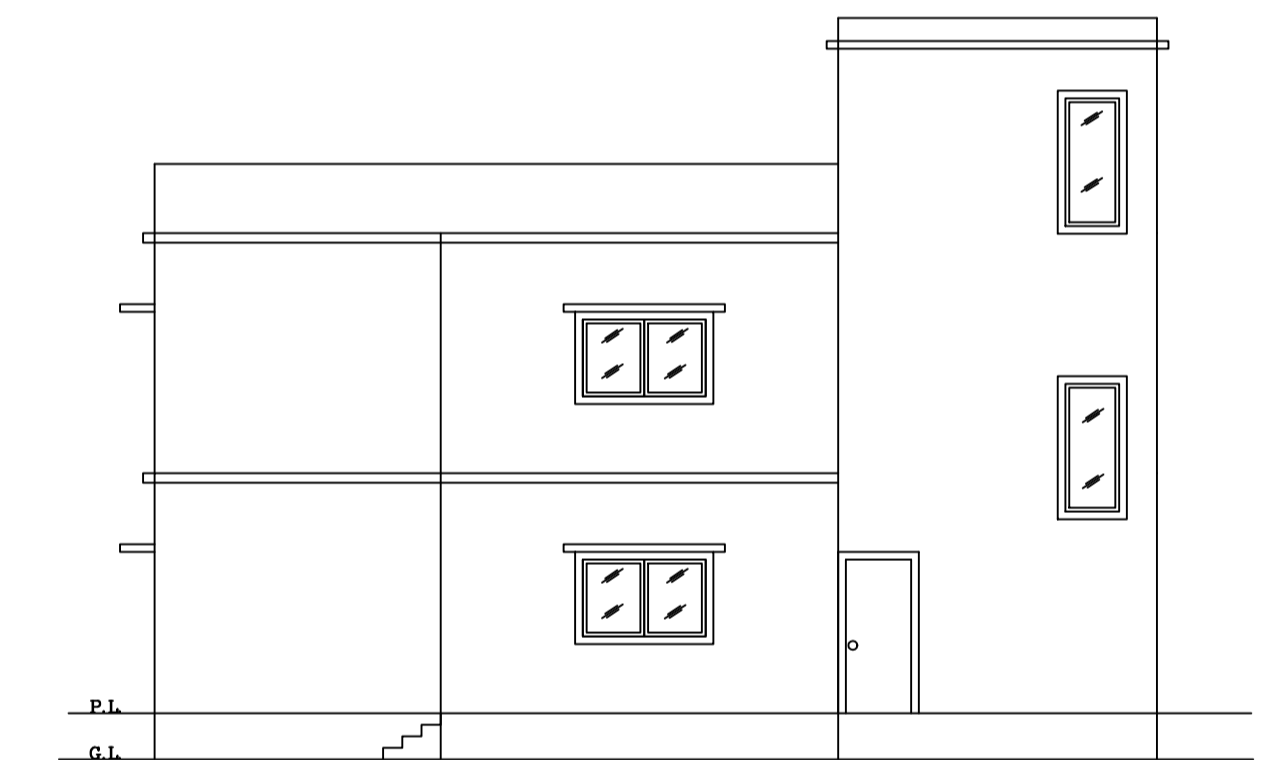

RIGHT SIDE ELEVATION (SCALE 1:100)

LTP NAME AND SIGNATURE	STRUCTURAL ENG'S NAME AND SIGNATURE	BUILDER NAME AND SIGNATURE	DIGITAL SIGNATURE
MAHENDRA MEHTA SINPC/DFTMN/0002/2022			

Proposal Basic Information	
Proposal File No.	SINPC/BP/0379/W02/2023
Owner Name	WILSON KERKETTA
Khata No	120
Plot No	4988
Village Name	Gotra
Use	Residential
SubUse	Bungalow/ Dwelling / Non Apartment

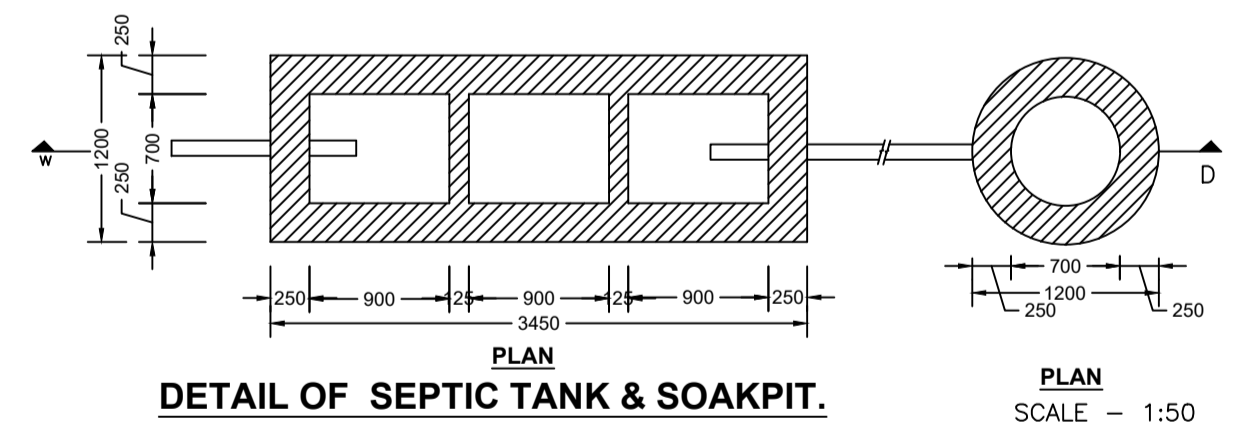
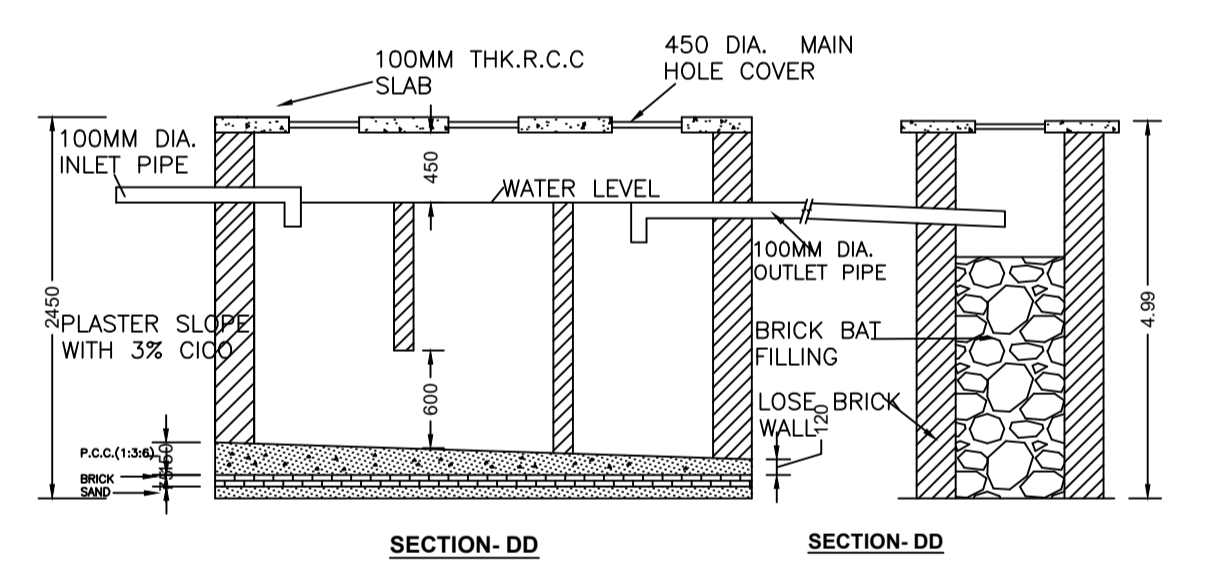
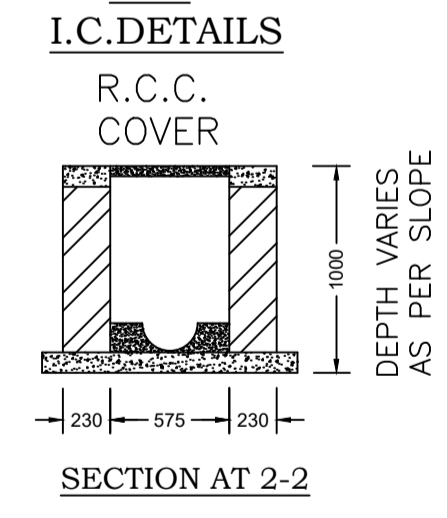
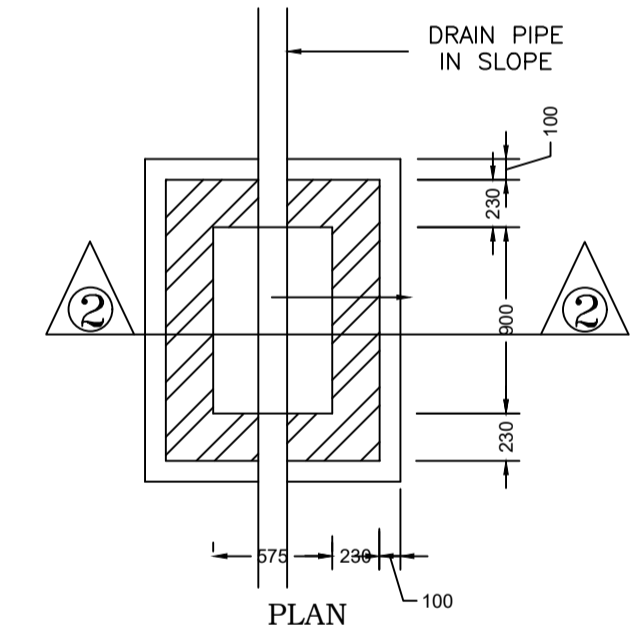
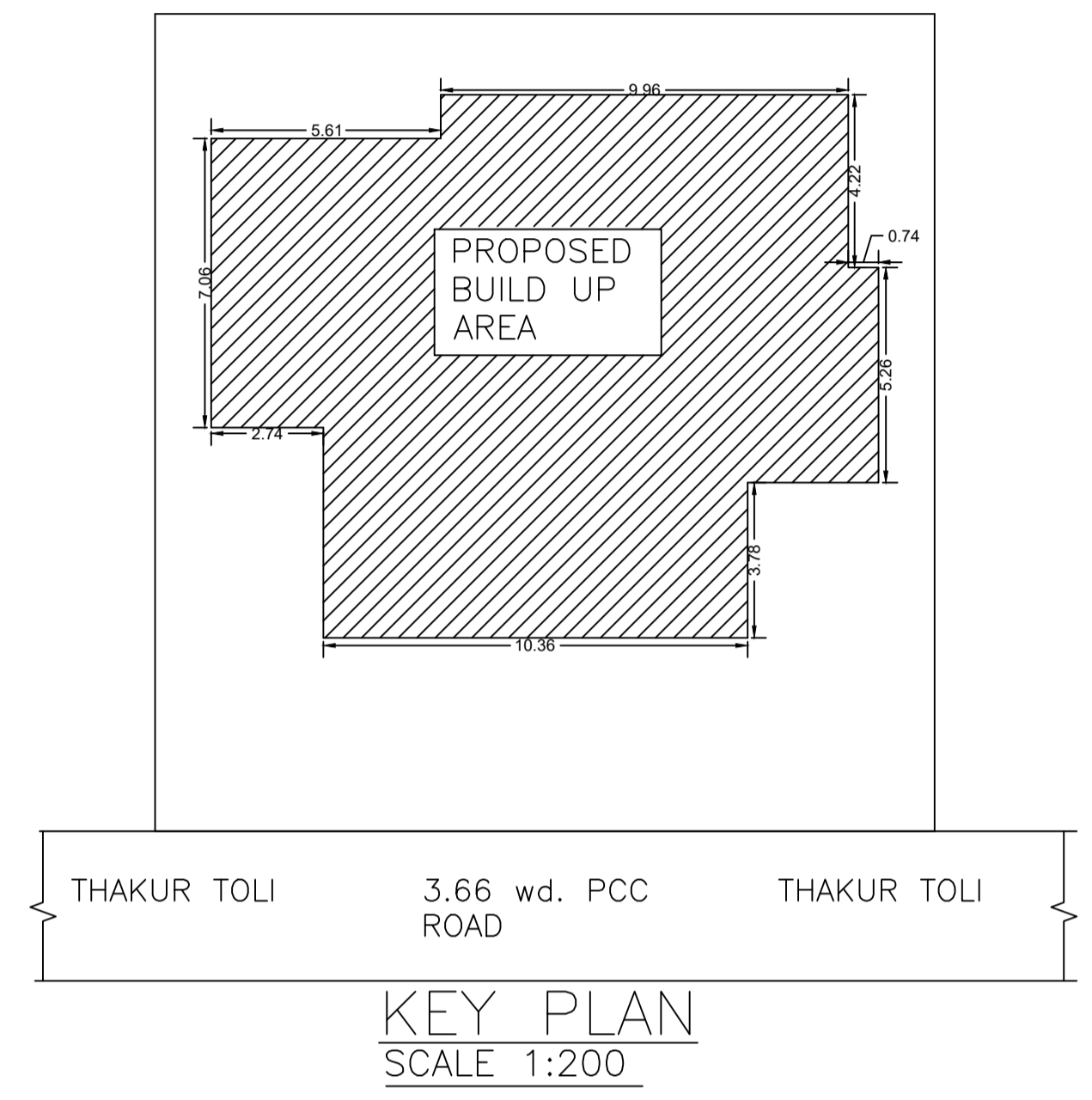
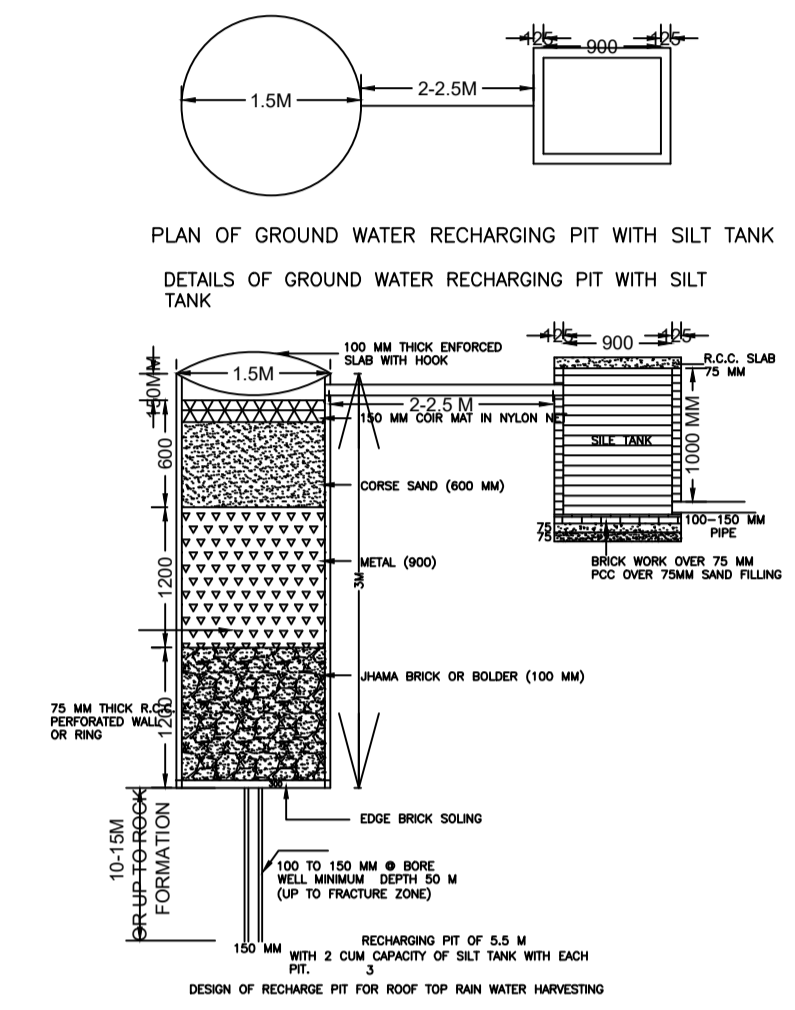

LTP NAME AND SIGNATURE	STRUCTURAL ENG'S NAME AND SIGNATURE	BUILDER NAME AND SIGNATURE	DIGITAL SIGNATURE
MAHENDRA MEHTA SINPC/DFTMN/0002/2022			