

Proposal Basic Information	
Proposal File No.	SINPC/BP/0386/W12/2023
Owner Name	SUSHILA TOPPO
Khata No	115
Plot No	44
Village Name	Simdega
Use	Residential
SubUse	Bungalow/ Dwelling / Non Apartment

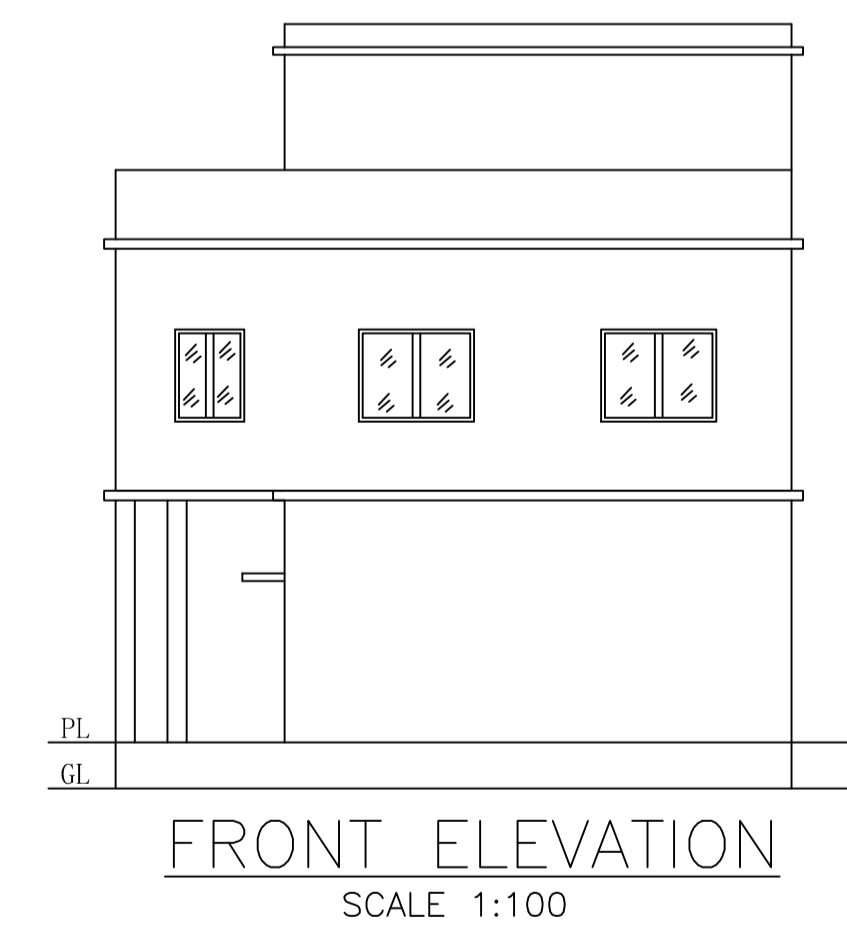
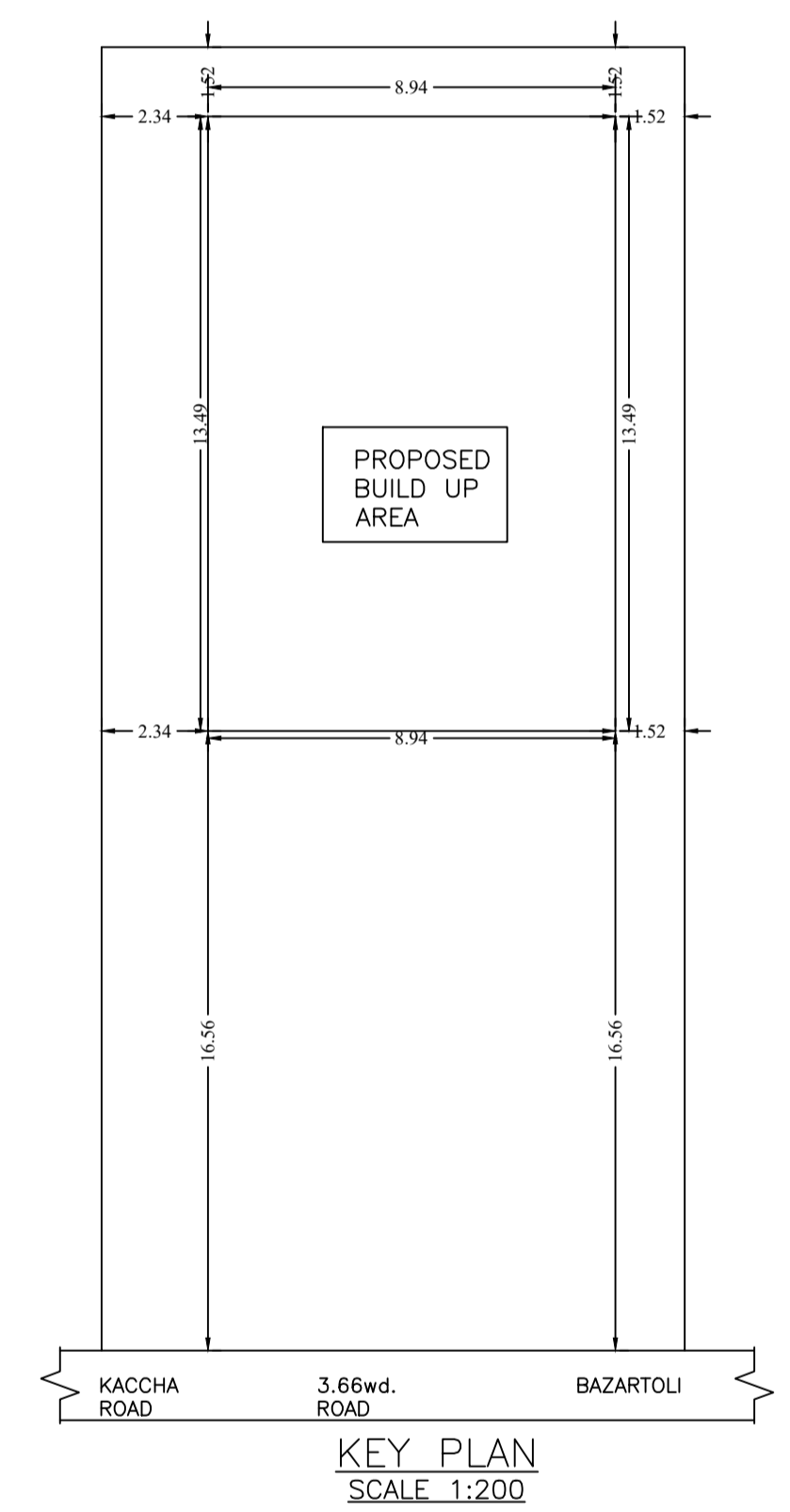
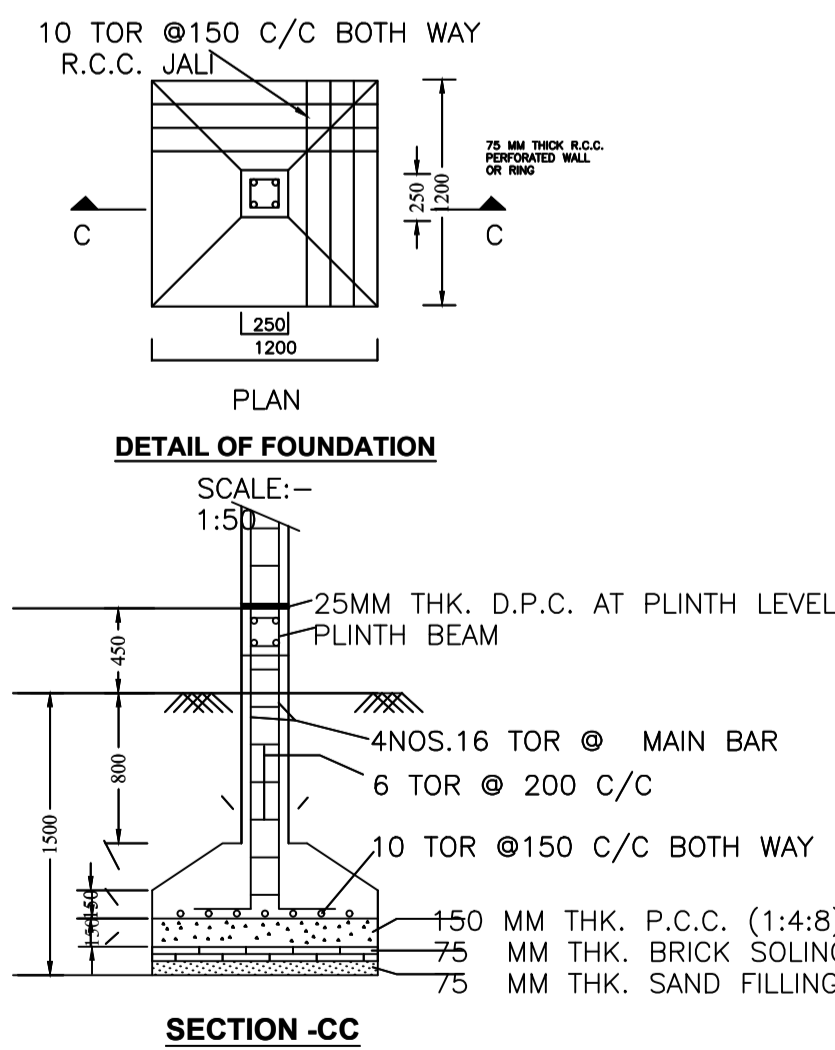
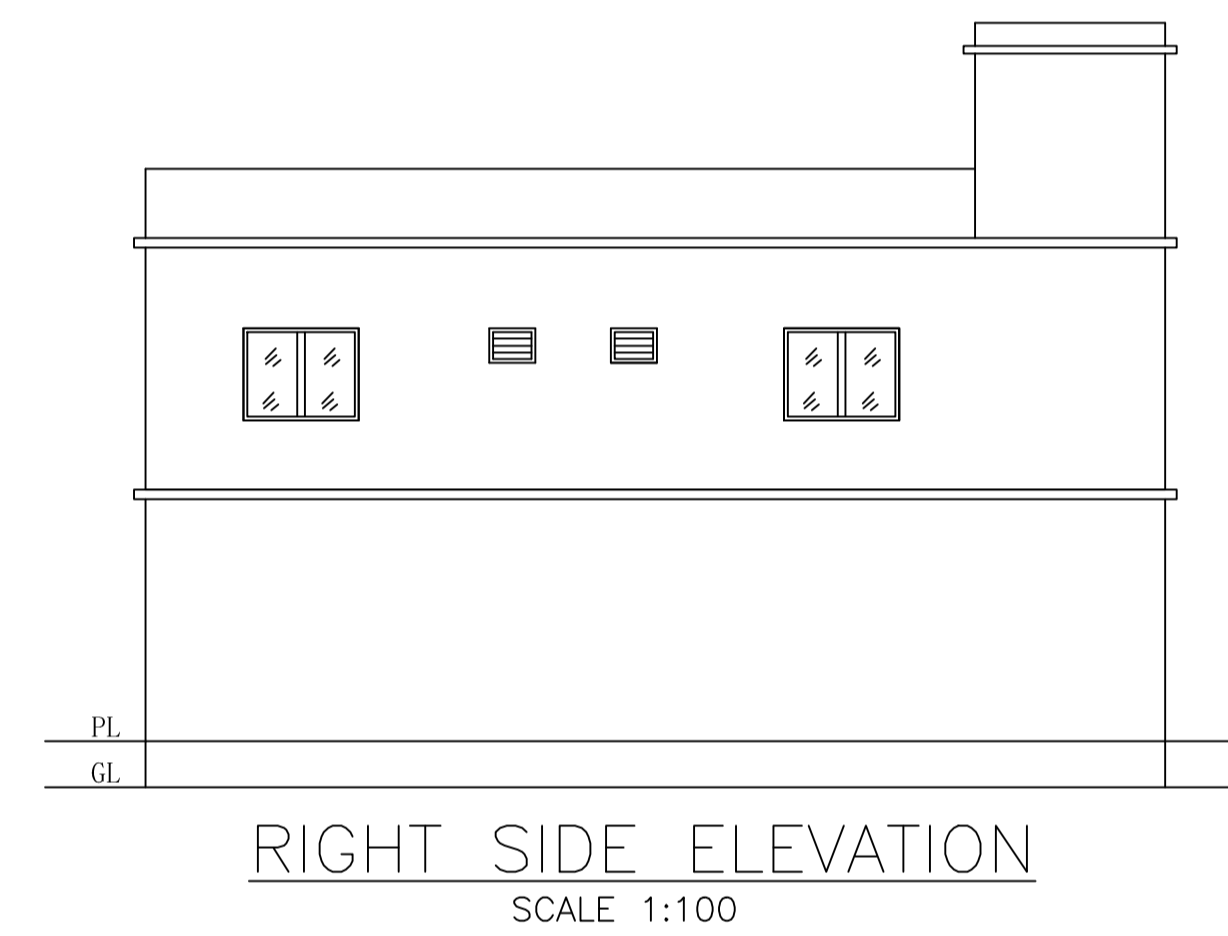
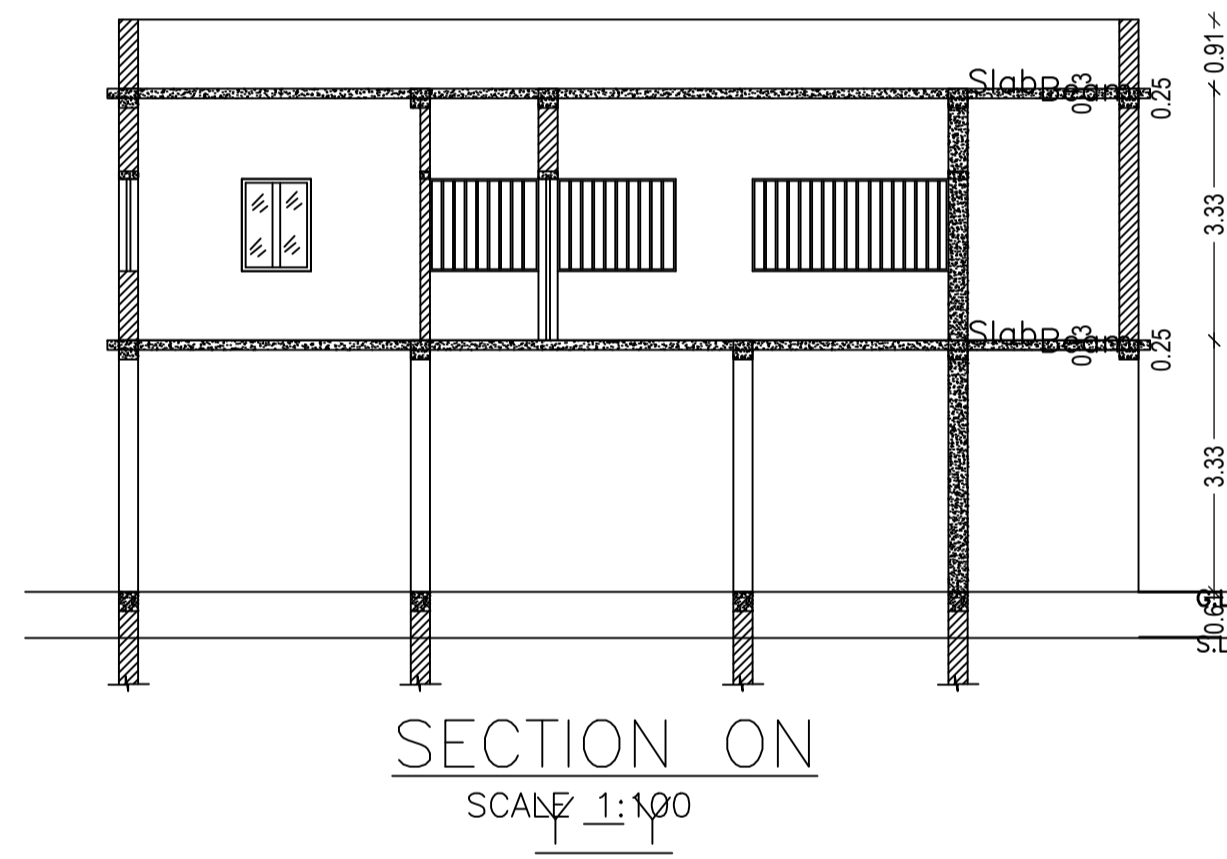
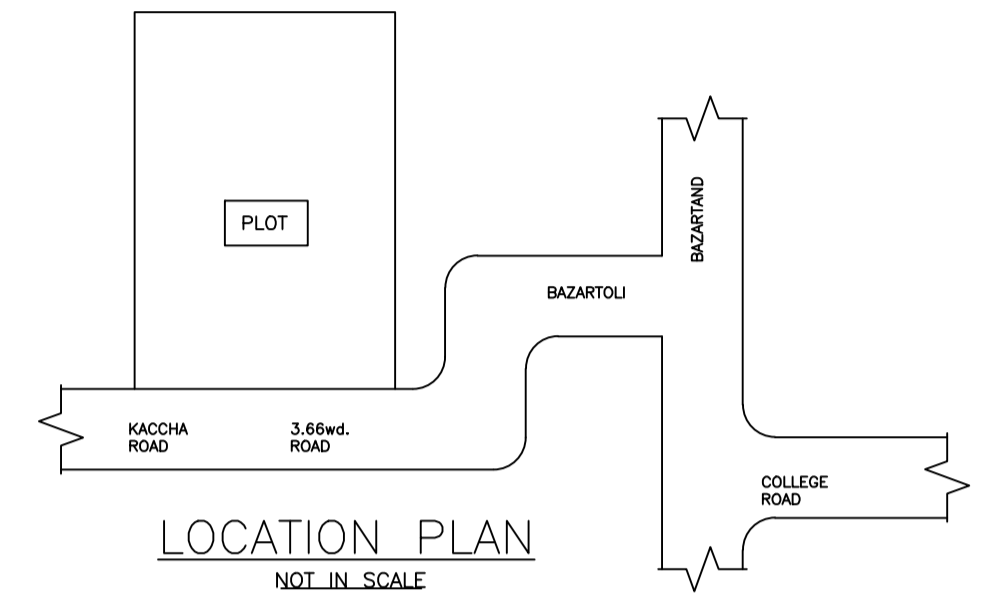
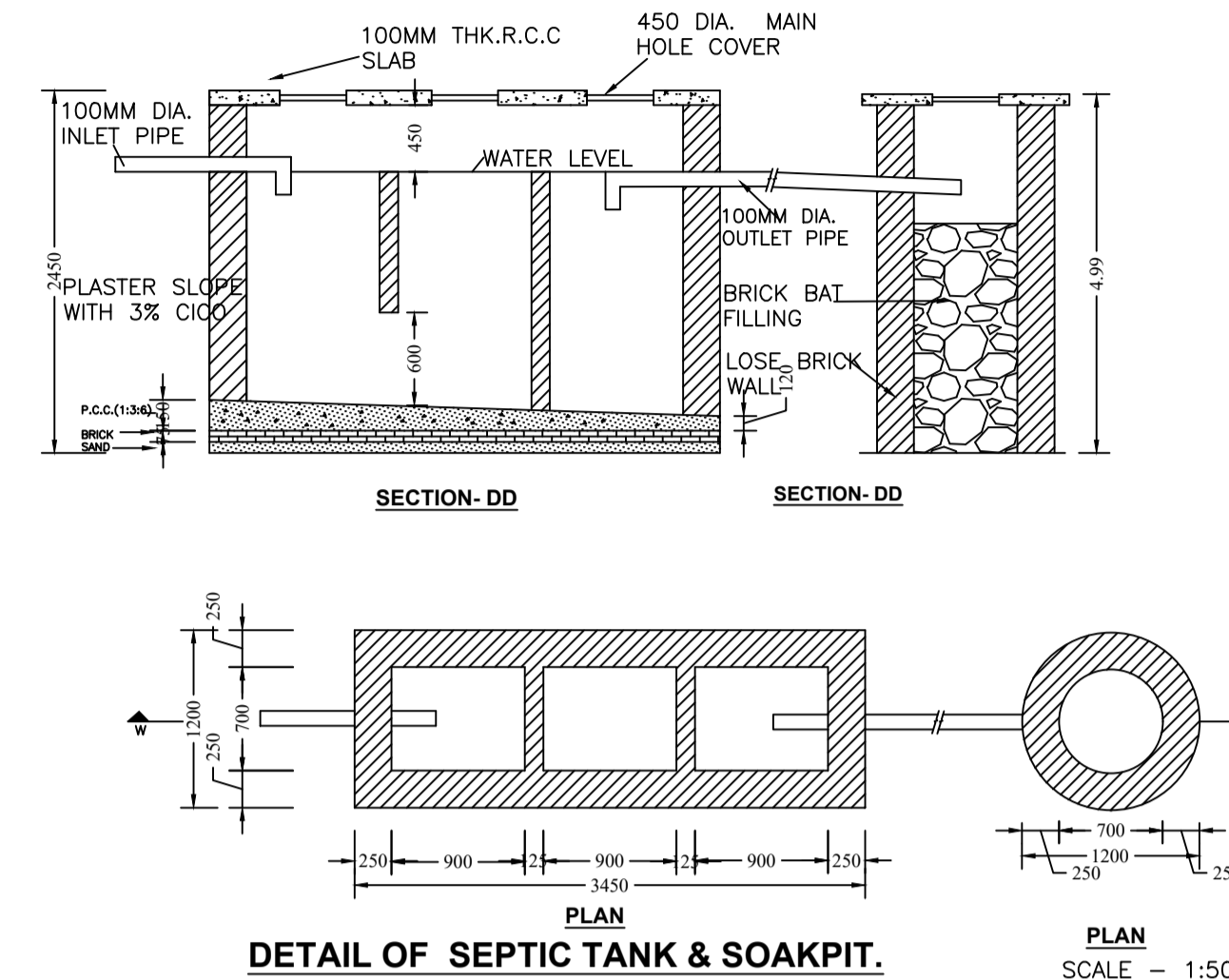
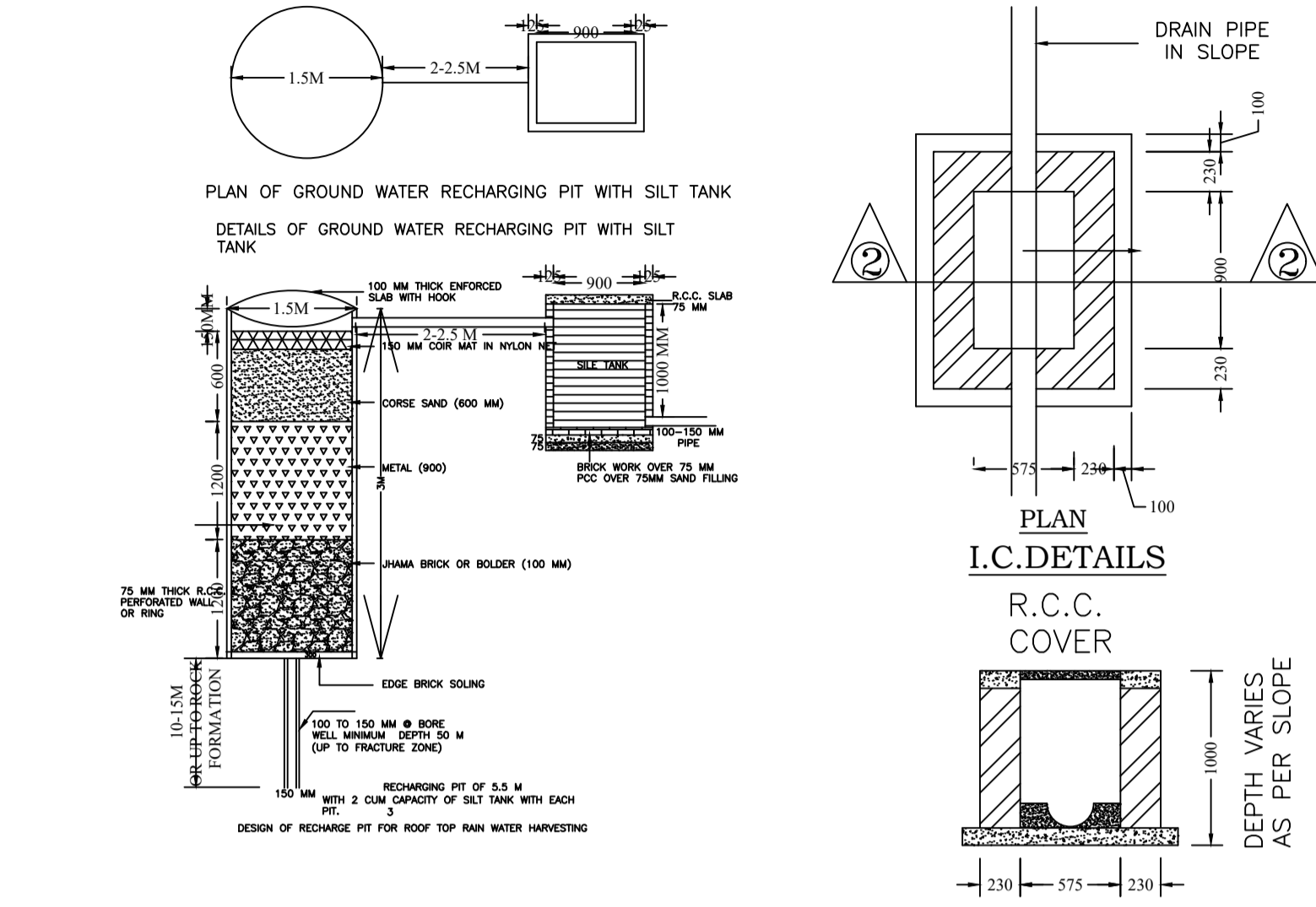
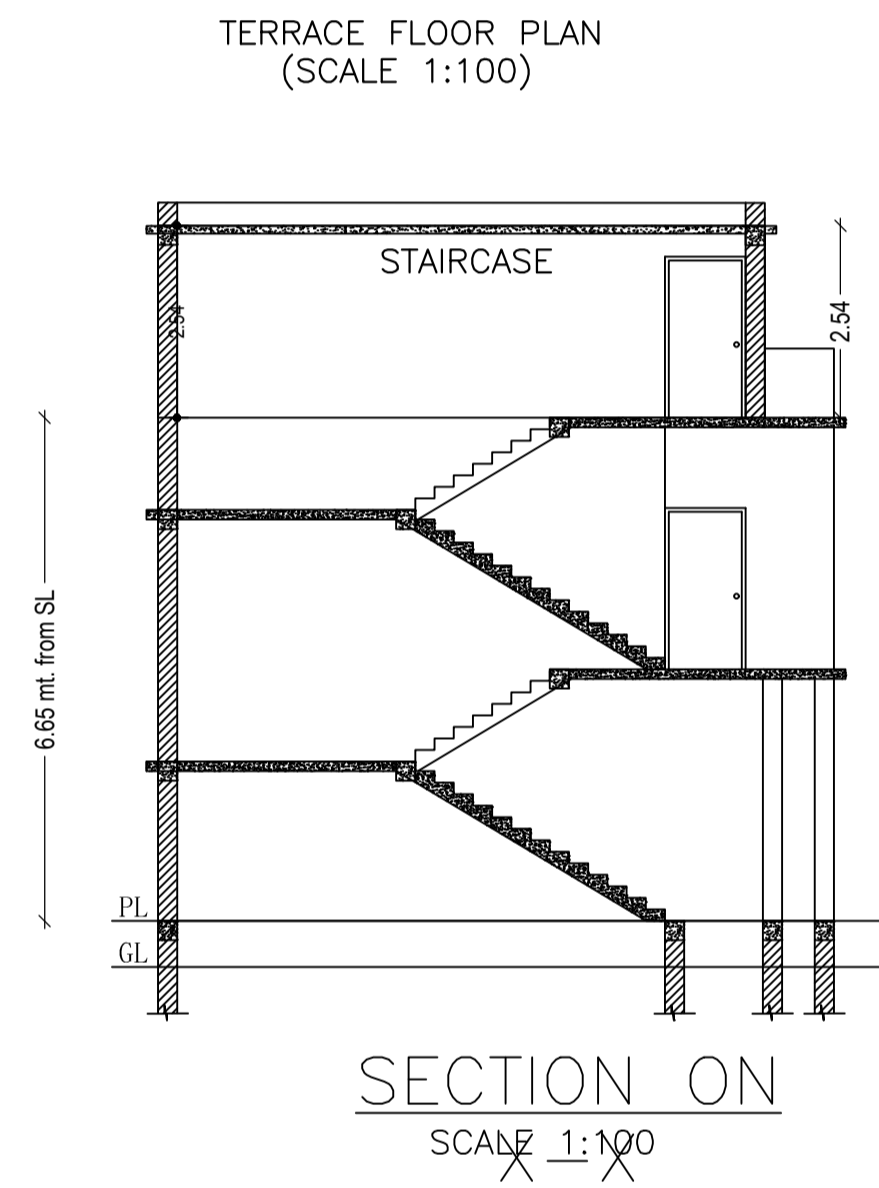
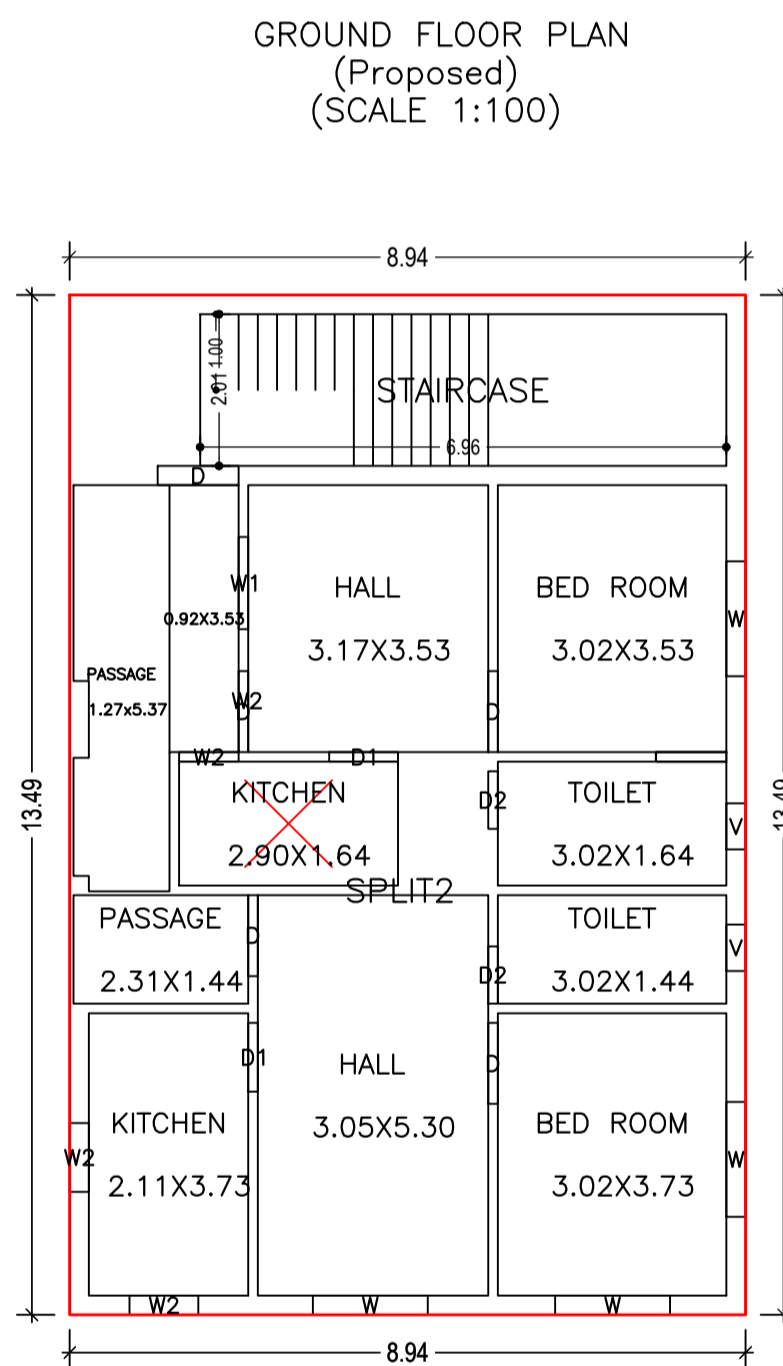
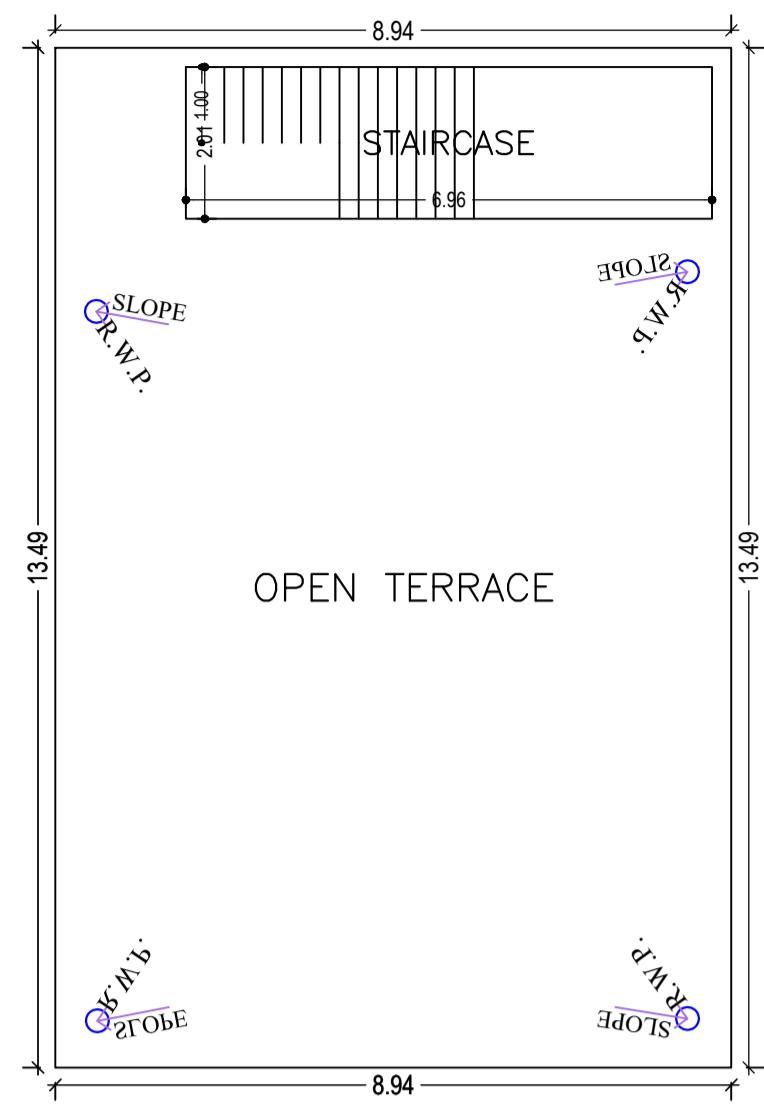
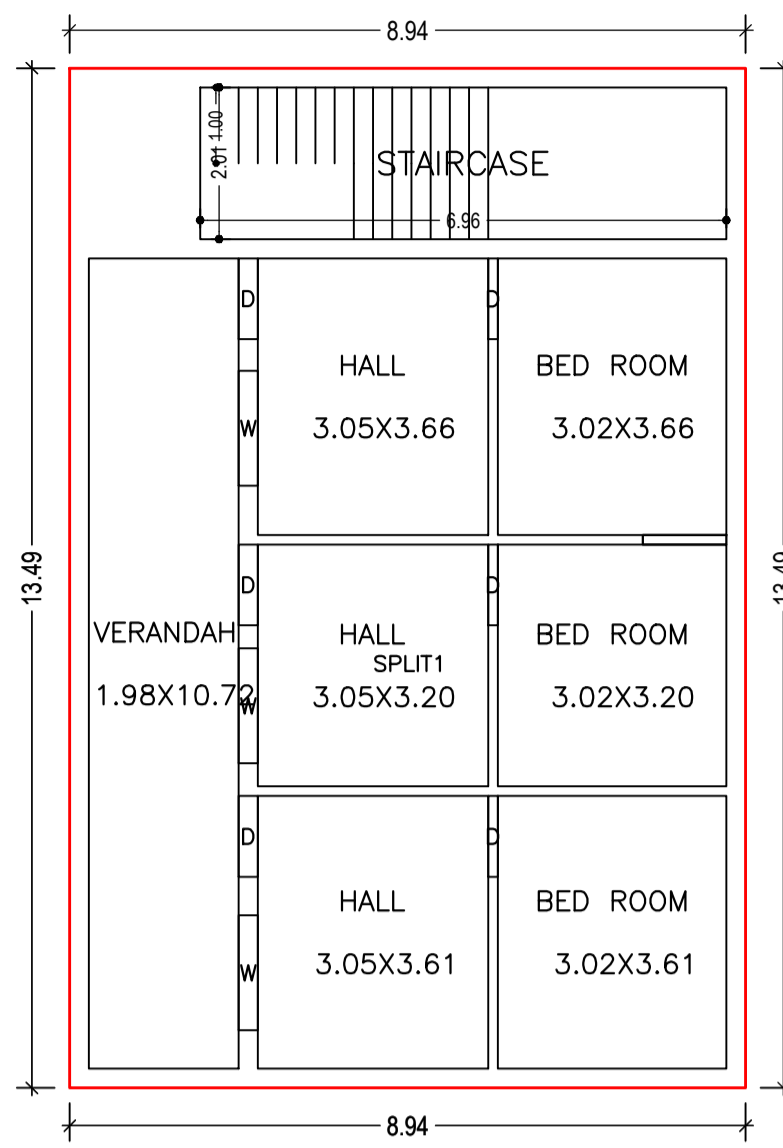

Building :A1 (RESIDENCE)					
Floor Name	Total Built Up Area (Sq.mt.)	Proposed FAR Area (Sq.mt.)	Total FAR Area (Sq.mt.)	Total Consumed Additional FAR Area (Sq.mt.)	Tnmt (No.)
Ground Floor	120.59	120.59	120.59	120.59	01
First Floor	120.59	120.59	120.59	120.59	01
Terrace Floor	0.00	0.00	0.00	0.00	00
Total :	241.18	241.18	241.18	241.18	02
Total Number of Same Buildings	1				
Total :	241.18	241.18	241.18	241.18	02

SCHEDULE OF DOOR:

BUILDING NAME	NAME	LENGTH	HEIGHT	NOS
A1 (RESIDENCE)	D2	0.76	2.10	02
A1 (RESIDENCE)	D1	0.91	2.10	02
A1 (RESIDENCE)	D	1.07	2.10	11

SCHEDULE OF WINDOW/VENTILATION:

BUILDING NAME	NAME	LENGTH	HEIGHT	NOS
A1 (RESIDENCE)	V	0.61	1.20	02
A1 (RESIDENCE)	W2	0.79	1.20	01
A1 (RESIDENCE)	W2	0.91	1.20	02
A1 (RESIDENCE)	W1	1.22	1.20	01
A1 (RESIDENCE)	W	1.52	1.20	07

UnitBUA Table for Building :A1 (RESIDENCE)

FLOOR	Name	UnitBUA Type	UnitBUA Area	Carpet Area	No. of Rooms	No. of Tenement
GROUND FLOOR PLAN	SPLIT1	FLAT	90.39	90.25	7	1
FIRST FLOOR PLAN	SPLIT2	FLAT	91.52	91.41	10	1
Total:	-	-	181.91	181.66	17	2

LTP NAME AND SIGNATURE	STRUCTURAL ENG'S NAME AND SIGNATURE	BUILDER NAME AND SIGNATURE	DIGITAL SIGNATURE
MAHENDRA MEHTA SINPC/DFTMN/002/2022			