

SIDE PLAN

(Scale - 1:200)

FAR & Tenement Details (Table 4c-1)

| Building       | No. of Same Bldg | Total Built Up Area (Sq.mt.) | Proposed FAR Area (Sq.mt.) Resi. | Total FAR Area (Sq.mt.) | Total Consumed Additional FAR Area (Sq.mt.) | Tnmt (No.) |
|----------------|------------------|------------------------------|----------------------------------|-------------------------|---|------------|
| A1 (RESIDENCE) | 1                | 182.40                       | 182.40                           | 182.40                  | 182.40                                      | 01         |
| Grand Total    | 1                | 182.40                       | 182.40                           | 182.40                  | 182.40                                      | 01         |

Proposal Basic Information

|                   |                                    |
|-------------------|------------------------------------|
| Proposal File No. | SINPC/BP/0388/W04/2023             |
| Owner Name        | JOLGEN BURH                        |
| Khata No          | 06                                 |
| Plot No           | 2221                               |
| Village Name      | Saldega                            |
| Use               | Residential                        |
| SubUse            | Bungalow/ Dwelling / Non Apartment |

|  |   |
|--|---|
| AREA STATEMENT SIMDEGA NAGAR PANCHAYAT                             | VERSION NO: 1.0.66                              |
| PROJECT DETAIL:  | VERSION DATE: 16/10/2020                        |
| Region: JHARKHAND URBAN LOCAL BODIES                               | Plot Use: Residential                           |
| District: SIMDEGA  | Plot SubUse: Bungalow/ Dwelling / Non Apartment |
| Authority: SIMDEGA NAGAR PANCHAYAT                                 | PlotNearbyReligiousStructure: NA                |
| Inward No: SINPC/BP/0388/W04/2023                                  | PlotSubPlot No: 2221                            |
| Application Type: General Proposal                                 | North: -  |
| Project Type: Building Permission                                  | South: -  |
| Nature of Development: New   | East: -   |
| Location of Development Area: Old Area                             | West: -   |
| AREA DETAILS:  | SQ.MT.  |
| AREA OF PLOT (Minimum)   | (A) 781.83                                      |
| Deduction for NetPlot Area   |   |
| Surrender Free of Cost   | 19.20   |
| Total  | 19.20   |
| NET AREA OF PLOT(Gross Plot Area - Deduction from Gross Plot area) | (A-Deductions) 762.63                           |
| Deduction for Balance Plot Area(from Gross Plot Area)              |   |
| Surrender Free of Cost   | 19.20   |
| Common Plot  | 43.56   |
| Total  | 62.77   |
| BALANCE AREA OF PLOT(Net Plot Area - Recreational/Amenity space)   | (A-Deductions) 719.06                           |
| PLOT AREA FOR COVERAGE(Net Plot Area)                              | (A-Deductions) 762.63                           |
| Plot Area for FAR (Net Plot Area + RoadWidening Area)              | (A-Deductions) 781.83                           |
| COVERAGE CHECK   |   |
| Permissible Coverage area ( 60.00 % )                              | 457.58  |
| Proposed Coverage Area ( 11.96 % )                                 | 91.20   |
| Total Prop. Coverage Area ( 11.96 % )                              | 91.20   |
| Balance coverage area ( 48.04 % )                                  | 366.38  |
| FAR CHECK  |   |
| Perm. FAR Area ( 1.500 )   | 1172.74   |
| Total Perm. FAR area   | 1172.74   |
| Residential FAR  | 182.40  |
| Proposed FAR Area  | 182.40  |
| Total Proposed FAR Area  | 182.40  |
| Consumed FAR (Factor)  | 0.23  |
| Balance FAR Area   | 990.34  |
| BUILT UP AREA CHECK  |   |
| Total Proposed BuiltUp Area  | 182.40  |
| ARCHITECT (Regd)   | MAHENDRA MEHTA                                  |
| ENGINEER (Regd)  |   |
| SUPERVISOR (Regd)  |   |
| OWNER (Regd)   | JOLGEN BURH                                     |
| DEVELOPMENT AUTHORITY  | LOCAL BODY                                      |

| COLOR INDEX                 |            |
|-----------------------------|------------|
| PLOT BOUNDARY               | Black      |
| ABUTTING ROAD               | Green      |
| PROPOSED CONSTRUCTION       | Red        |
| COMMON PLOT                 | Yellow     |
| ROAD WIDENING AREA          | Orange     |
| EXISTING (To be retained)   | Blue       |
| EXISTING (To be demolished) | Light Blue |

Buildingwise Floor FAR Details

| Floor Name    | Building Name A1 (RESIDENCE)    |                            | Total                                 |                         |
|---------------|---------------------------------|----------------------------|---------------------------------------|-------------------------|
|               | Proposed Built Up Area (Sq.mt.) | Proposed FAR Area (Sq.mt.) | Total Proposed Built Up Area (Sq.mt.) | Total FAR Area (Sq.mt.) |
| Ground Floor  | 91.20                           | 91.20                      | 91.20                                 | 91.20                   |
| First Floor   | 91.20                           | 91.20                      | 91.20                                 | 91.20                   |
| Terrace Floor | 0.00                            | 0.00                       | 0.00                                  | 0.00                    |
| Total         | 182.40                          | 182.40                     | 182.40                                | 182.40                  |

Building USE/SUBUSE Details

| Building Name  | Building Use | Building SubUse                    | Building Structure |
|----------------|--------------|------------------------------------|--------------------|
| A1 (RESIDENCE) | Residential  | Bungalow/ Dwelling / Non Apartment | Non-Highrise       |

| LTP NAME AND SIGNATURE                  | STRUCTURAL ENG'S NAME AND SIGNATURE | BUILDER NAME AND SIGNATURE | DIGITAL SIGNATURE |
|---|-------------------------------------|----------------------------|-------------------|
| MAHENDRA MEHTA<br>SINPC/DFTMN/0002/2022 |                                     |                            |                   |

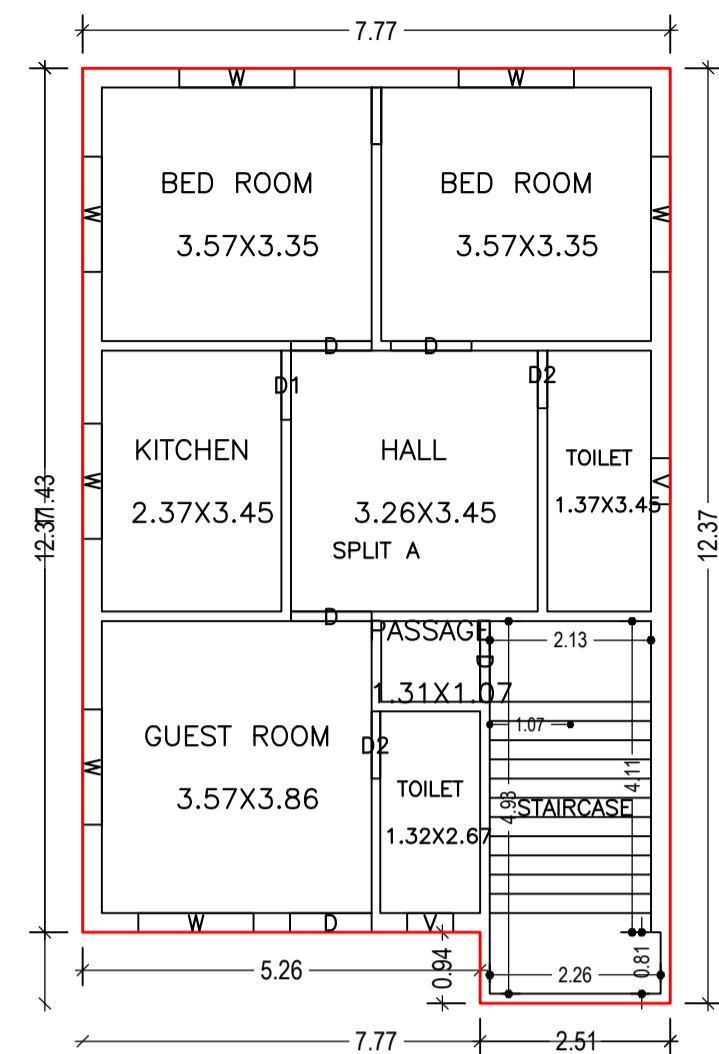

GROUND FLOOR PLAN (Proposed) (SCALE 1:100)

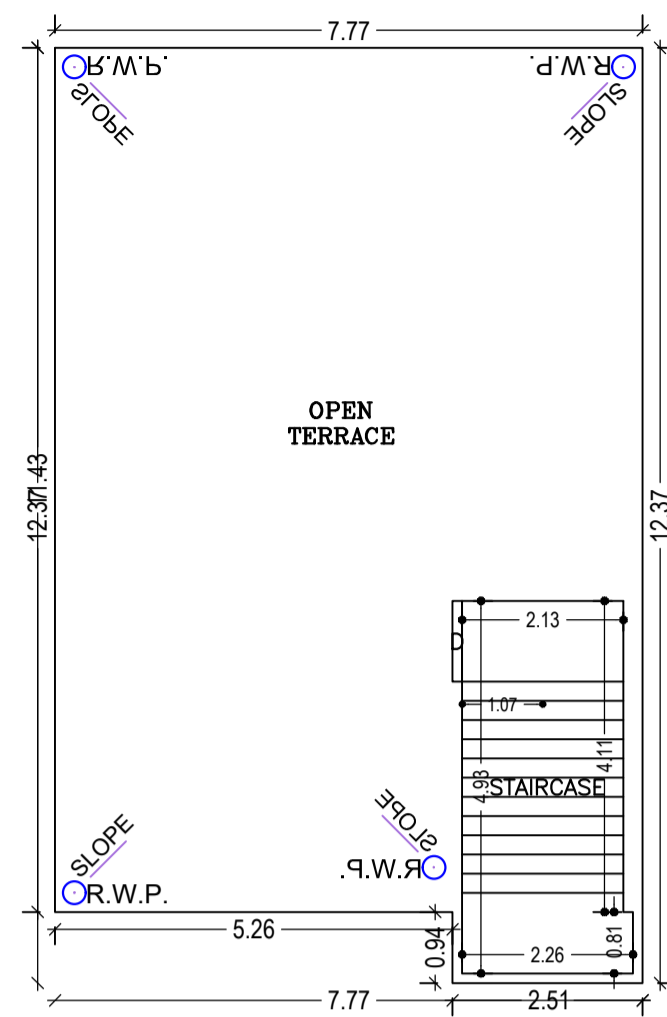

TERRACE FLOOR PLAN (SCALE 1:100)

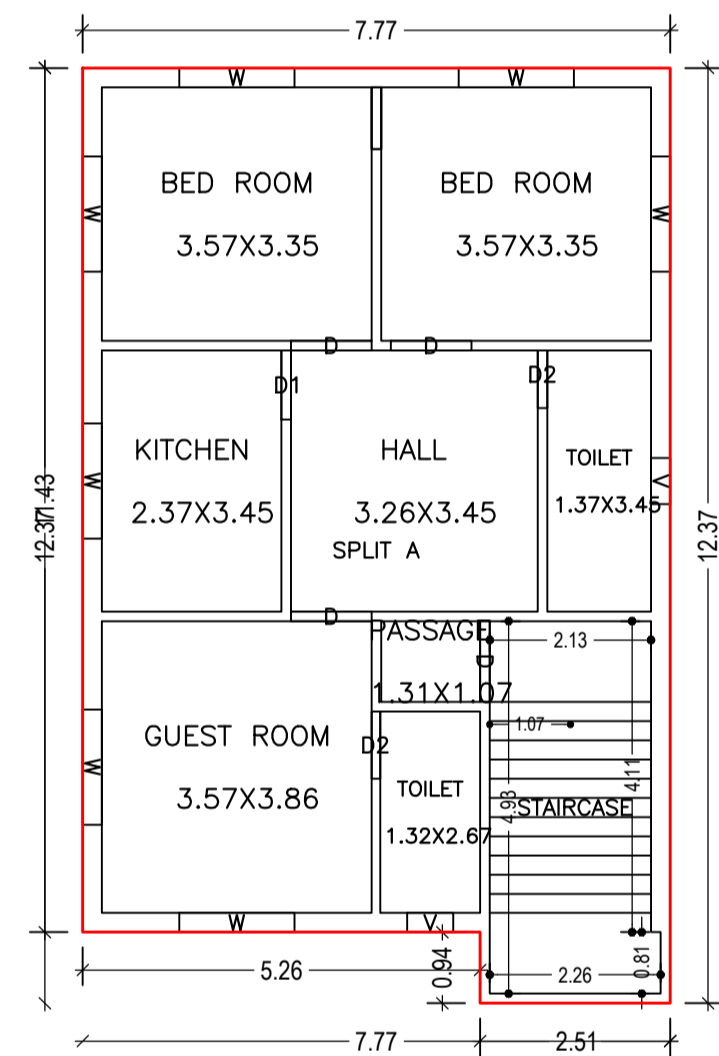

FIRST FLOOR PLAN (Proposed) (SCALE 1:100)

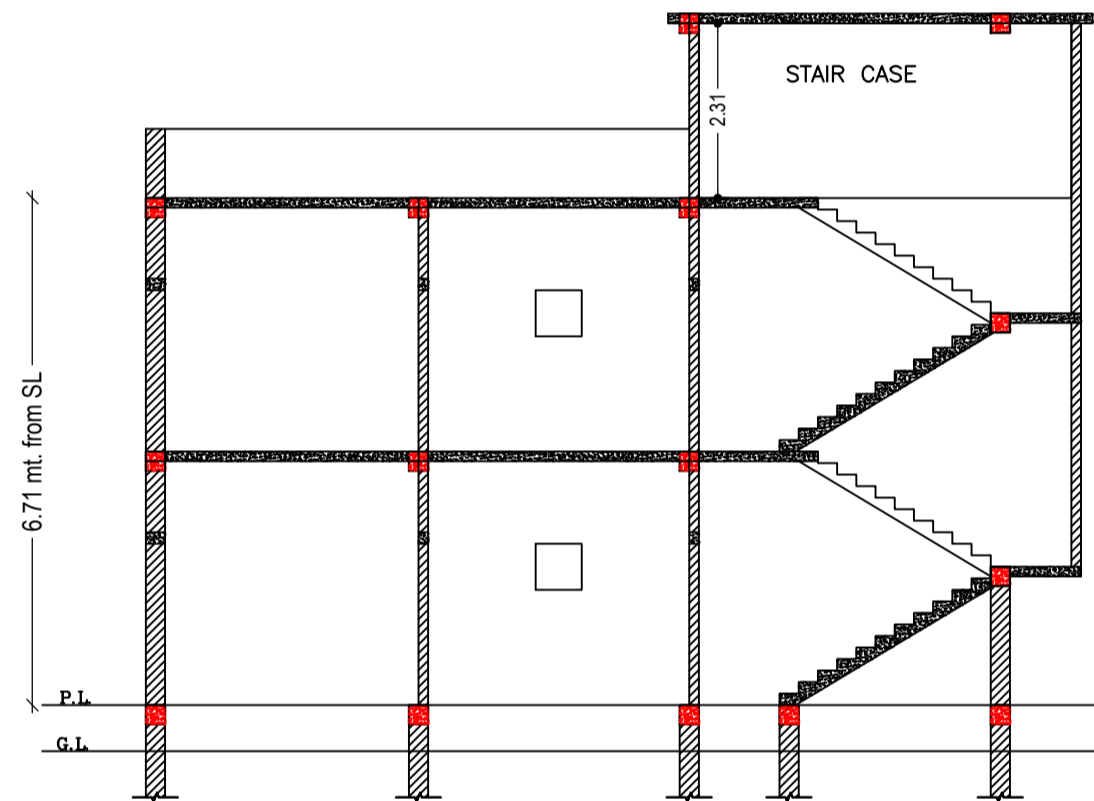

SECTION ON SCALE 1:100

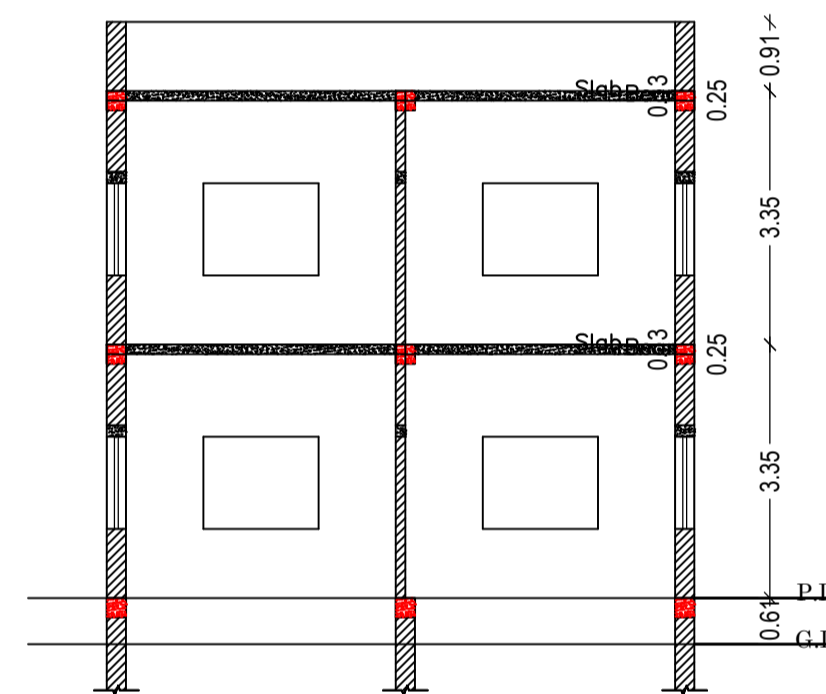

SECTION ON SCALE 1:100

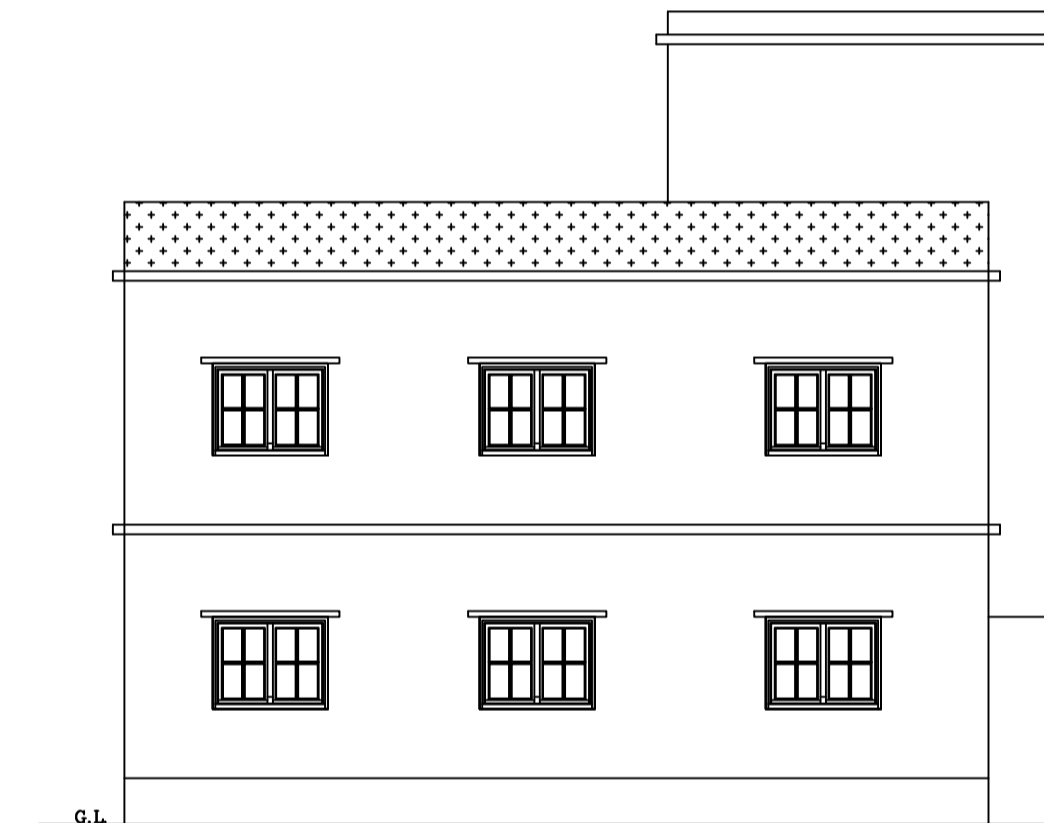

RIGHT SIDE ELEVATION SCALE 1:100

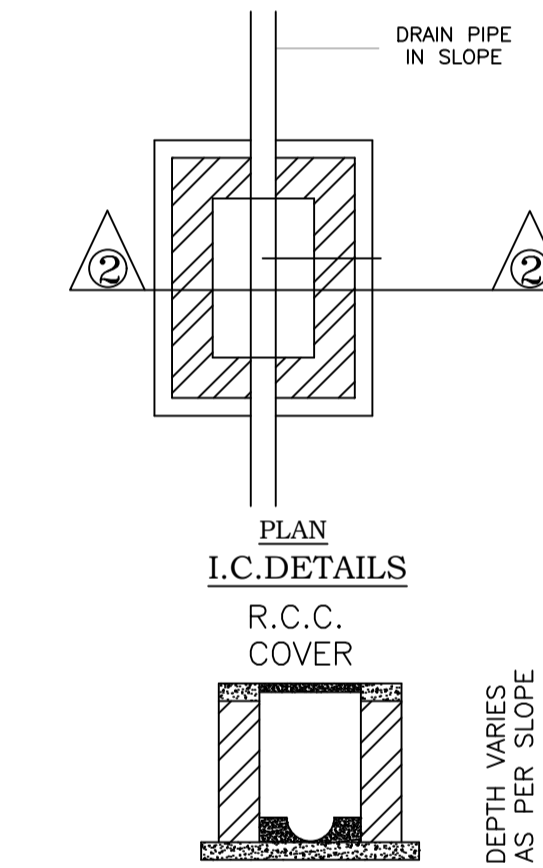

PLAN I.C. DETAILS R.C.C. COVER

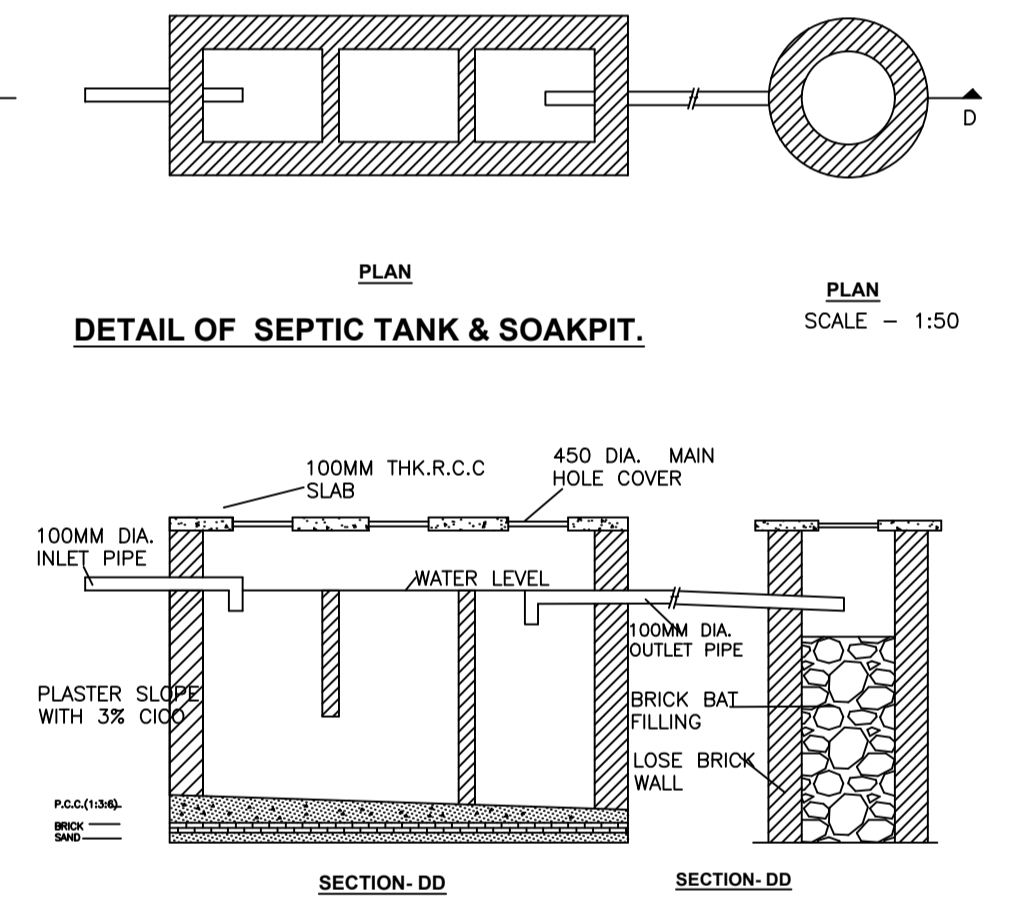

DETAIL OF SEPTIC TANK & SOAKPIT. SCALE - 1:50



FRONT ELEVATION SCALE 1:100

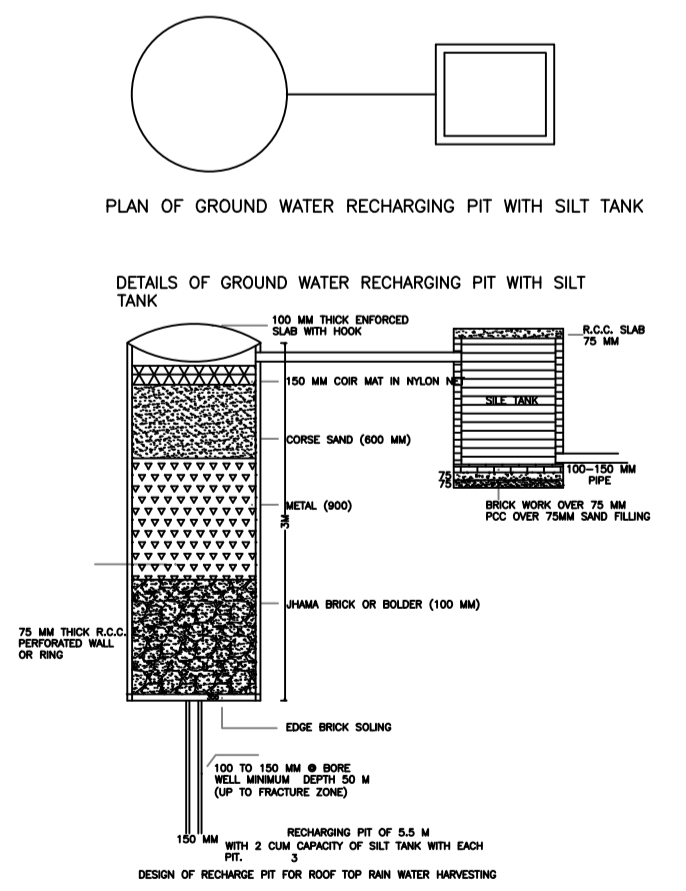

DETAILS OF GROUND WATER RECHARGING PIT WITH SILT TANK

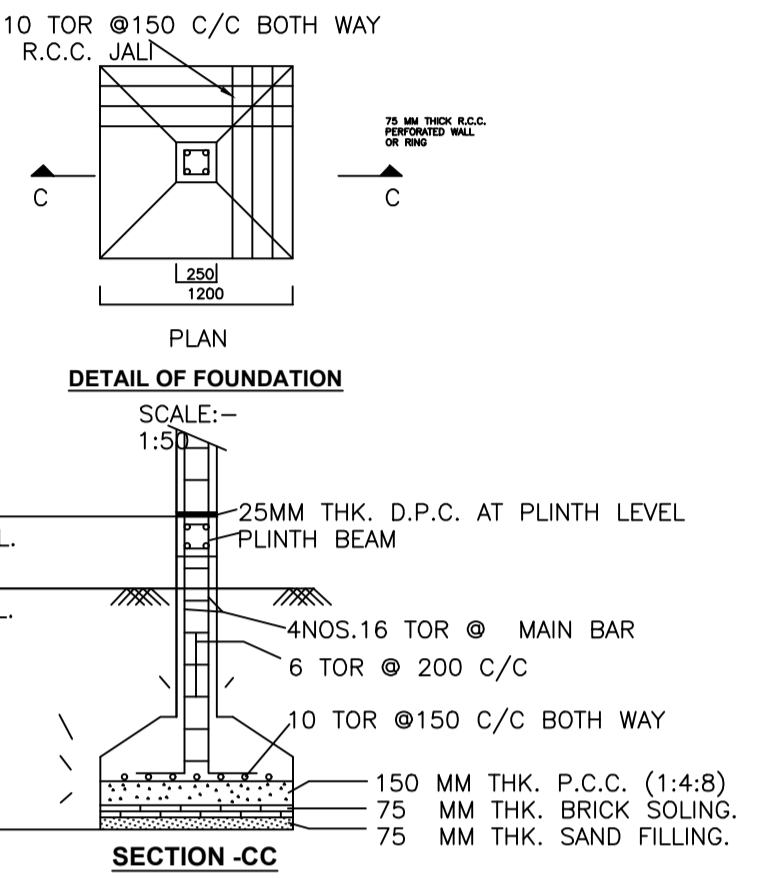

LOCATION PLAN NOT TO SCALE

DETAIL OF FOUNDATION SCALE:- 1:50

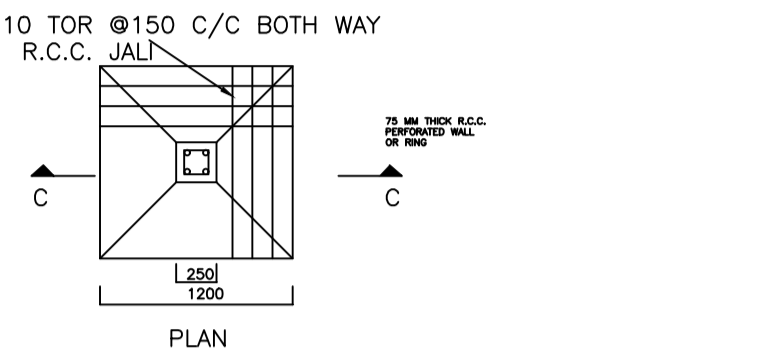

PLAN SCALE:- 1:50

10 TOR @ 150 C/C BOTH WAY  
R.C.C. JALI

25MM THK. D.P.C. AT PLINTH LEVEL  
PLINTH BEAM  
4NOS.16 TOR @ MAIN BAR  
6 TOR @ 200 C/C  
10 TOR @ 150 C/C BOTH WAY  
150 MM THK. P.C.C. (1:4:8)  
75 MM THK. BRICK SOLING  
75 MM THK. SAND FILLING.

| Floor Name                     | Total Built Up Area (Sq.mt.) | Proposed FAR Area (Sq.mt.) | Total FAR Area (Sq.mt.) | Total Consumed Additional FAR Area (Sq.mt.) | Tnmt (No.) |
|--------------------------------|------------------------------|----------------------------|-------------------------|---|------------|
| Ground Floor                   | 91.20                        | 91.20                      | 91.20                   | 91.20                                       | 01         |
| First Floor                    | 91.20                        | 91.20                      | 91.20                   | 91.20                                       | 00         |
| Terrace Floor                  | 0.00                         | 0.00                       | 0.00                    | 0.00  | 00         |
| Total :                        | 182.40                       | 182.40                     | 182.40                  | 182.40                                      | 01         |
| Total Number of Same Buildings | 1                            |                            |                         |   |            |
| Total :                        | 182.40                       | 182.40                     | 182.40                  | 182.40                                      | 01         |

SCHEDULE OF DOOR:

| BUILDING NAME  | NAME | LENGTH | HEIGHT | NOS |
|----------------|------|--------|--------|-----|
| A1 (RESIDENCE) | D2   | 0.76   | 2.10   | 02  |
| A1 (RESIDENCE) | D2   | 0.89   | 2.10   | 02  |
| A1 (RESIDENCE) | D1   | 0.91   | 2.10   | 02  |
| A1 (RESIDENCE) | D    | 1.07   | 2.10   | 08  |
| A1 (RESIDENCE) | D    | 1.08   | 2.10   | 01  |

SCHEDULE OF WINDOW/VENTILATION:

| BUILDING NAME  | NAME | LENGTH | HEIGHT | NOS |
|----------------|------|--------|--------|-----|
| A1 (RESIDENCE) | V    | 0.61   | 1.20   | 04  |
| A1 (RESIDENCE) | W    | 1.52   | 1.20   | 14  |

UnitBUA Table for Building :A1 (RESIDENCE)

| FLOOR             | Name    | UnitBUA Type | UnitBUA Area | Carpet Area | No. of Rooms | No. of Tenement |
|-------------------|---------|--------------|--------------|-------------|--------------|-----------------|
| GROUND FLOOR PLAN | SPLIT A | FLAT         | 140.65       | 140.45      | 8            | 1               |
| FIRST FLOOR PLAN  | SPLIT A | FLAT         | 0.00         | 0.00        | 8            | 0               |
| Total:            | -       | -            | 140.65       | 140.45      | 16           | 1               |

| LTP NAME AND SIGNATURE                  | STRUCTURAL ENG'S NAME AND SIGNATURE | BUILDER NAME AND SIGNATURE | DIGITAL SIGNATURE |
|---|-------------------------------------|----------------------------|-------------------|
| MAHENDRA MEHTA<br>SINPC/DFTMN/0002/2022 |                                     |                            |                   |

| Proposal Basic Information |                                    |
|----------------------------|------------------------------------|
| Proposal File No.          | SINPC/BP/0388/W04/2023             |
| Owner Name                 | JOLGEN BURH                        |
| Khata No                   | 06                                 |
| Plot No                    | 2221                               |
| Village Name               | Saldega                            |
| Use                        | Residential                        |
| SubUse                     | Bungalow/ Dwelling / Non Apartment |

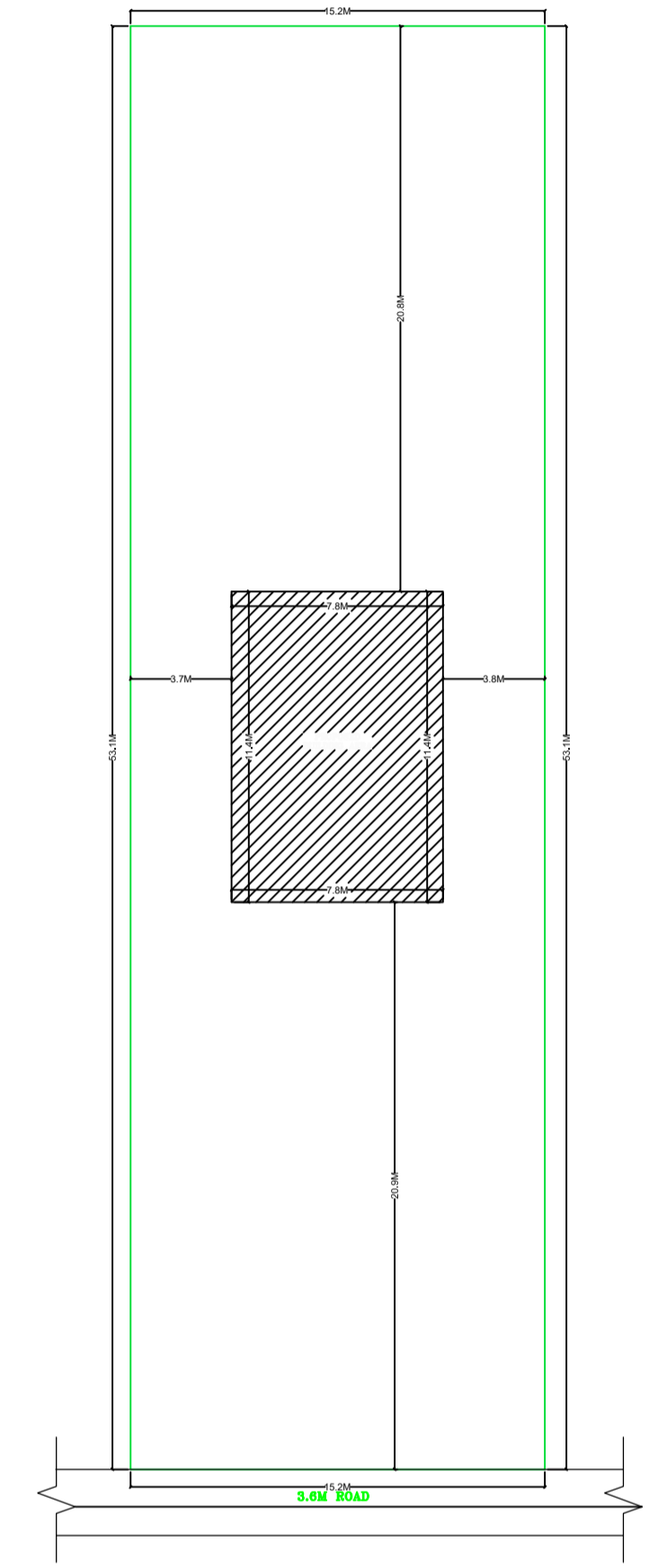

KEY PLAN  
SCALE 1:200

| LTP NAME AND SIGNATURE                  | STRUCTURAL ENG'S NAME AND SIGNATURE | BUILDER NAME AND SIGNATURE | DIGITAL SIGNATURE |
|---|-------------------------------------|----------------------------|-------------------|
| MAHENDRA MEHTA<br>SINPC/DFTMN/0002/2022 |                                     |                            |                   |