

# SITE PLAN

FAR & Tenement Details (Table 4c-1)

Building	No. of Same Bldg	Total Built Up Area (Sq.mt.)	Proposed FAR Area (Sq.mt.) Resi.	Total FAR Area (Sq.mt.)	Total Consumed Additional FAR Area (Sq.mt.)	Tnmt (No.)
A (RESIDENCE)	1	228.44	228.44	228.44	228.44	01
Grand Total	1	228.44	228.44	228.44	228.44	01

Proposal Basic Information

Proposal File No.	SINPC/BP/0439/W06/2023
Owner Name	RENU RANJITA KULLU
Khata No	113
Plot No	2490
Village Name	Khijri
Use	Residential
SubUse	Bungalow/ Dwelling / Non Apartment

AREA STATEMENT SIMDEGA NAGAR PANCHAYAT	VERSION NO: 1.0.66	SQ.MT.
PROJECT DETAIL	VERSION DATE: 16/10/2020	
Region: JHARKHAND URBAN LOCAL BODIES	Plot Use: Residential	
District: SIMDEGA	Plot SubUse: Bungalow/ Dwelling / Non Apartment	
Authority: SIMDEGA NAGAR PANCHAYAT	PlotNearbyReligiousStructure: NA	
Inward No: SINPC/BP/0439/W06/2023	PlotSubPlot No: 2490	
Application Type: General Proposal	North: -	
Project Type: Building Permission	South: -	
Nature of Development: New	East: -	
Location of Development Area: Old Area	West: -	
AREA DETAILS:		
AREA OF PLOT (Minimum)	(A)	222.41
Deduction for NetPlot Area		
Surrender Free of Cost		9.35
Total		9.35
NET AREA OF PLOT(Gross Plot Area - Deduction from Gross Plot area)	(A-Deductions)	213.06
Deduction for Balance Plot Area(from Gross Plot Area)		
Surrender Free of Cost		9.35
Common Plot		13.53
Total		22.88
BALANCE AREA OF PLOT(Net Plot Area - Recreational/Amenity space)	(A-Deductions)	199.53
PLOT AREA FOR COVERAGE(Net Plot Area)	(A-Deductions)	213.06
Plot Area for FAR (Net Plot Area + RoadWidening Area)	(A-Deductions)	222.41
COVERAGE CHECK		
Permissible Coverage area ( 70.00 % )		149.14
Proposed Coverage Area ( 53.61 % )		114.22
Total Prop. Coverage Area ( 53.61 % )		114.22
Balance coverage area ( 16.39 % )		34.92
FAR CHECK		
Perm. FAR Area ( 1.500 )		333.61
Total Perm. FAR area		333.61
Residential FAR		228.44
Proposed FAR Area		228.44
Total Proposed FAR Area		228.44
Consumed FAR (Factor)		1.03
Balance FAR Area		105.17
BUILT UP AREA CHECK		
Total Proposed BuiltUp Area		228.44
ARCHITECT (Regd)	MAHENDRA MEHTA	
ENGINEER (Regd)		
SUPERVISOR (Regd)		
OWNER (Regd)	RENU RANJITA KULLU	
DEVELOPMENT AUTHORITY	LOCAL BODY	

COLOR INDEX	
PLOT BOUNDARY	Black
ABUTTING ROAD	Green
PROPOSED CONSTRUCTION	Red
COMMON PLOT	Yellow
ROAD WIDENING AREA	Orange
EXISTING (To be retained)	Blue
EXISTING (To be demolished)	Light Blue

Buildingwise Floor FAR Details

Floor Name	Building Name A (RESIDENCE)		Total	
	Proposed Built Up Area (Sq.mt.)	Proposed FAR Area (Sq.mt.)	Total Proposed Built Up Area (Sq.mt.)	Total FAR Area (Sq.mt.)
Ground Floor	114.22	114.22	114.22	114.22
First Floor	114.22	114.22	114.22	114.22
Terrace Floor	0.00	0.00	0.00	0.00
Total	228.44	228.44	228.44	228.44

Building USE/SUBUSE Details

Building Name	Building Use	Building SubUse	Building Structure
A (RESIDENCE)	Residential	Bungalow/ Dwelling / Non Apartment	Non-Highrise

LTP NAME AND SIGNATURE	STRUCTURAL ENG'S NAME AND SIGNATURE	BUILDER NAME AND SIGNATURE	DIGITAL SIGNATURE
MAHENDRA MEHTA SINPC/DFTMN/0002/2022			

Proposal Basic Information	
Proposal File No.	SINPC/0439/W06/2023
Owner Name	RENU RANJITA KULLU
Khata No	113
Plot No	2490
Village Name	Khijri
Use	Residential
SubUse	Bungalow/ Dwelling / Non Apartment

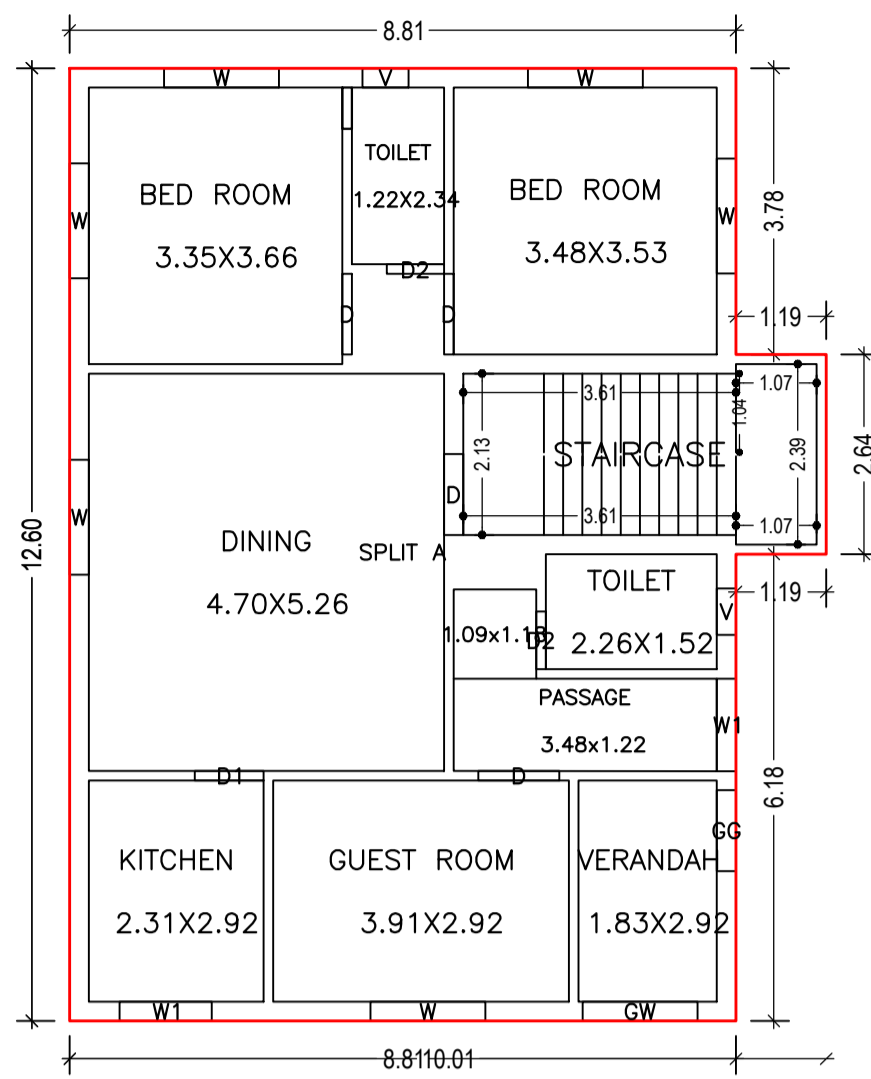

GROUND FLOOR PLAN  
(Proposed)  
(SCALE 1:100)

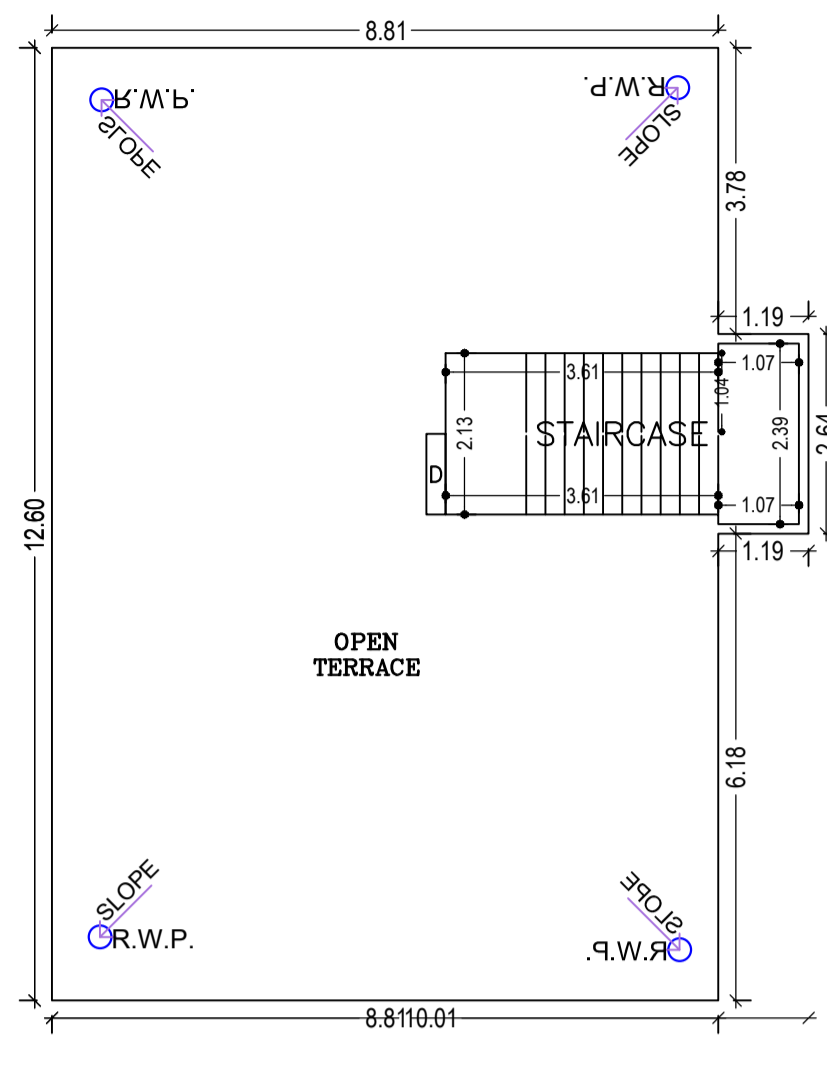

TERRACE FLOOR PLAN  
(SCALE 1:100)

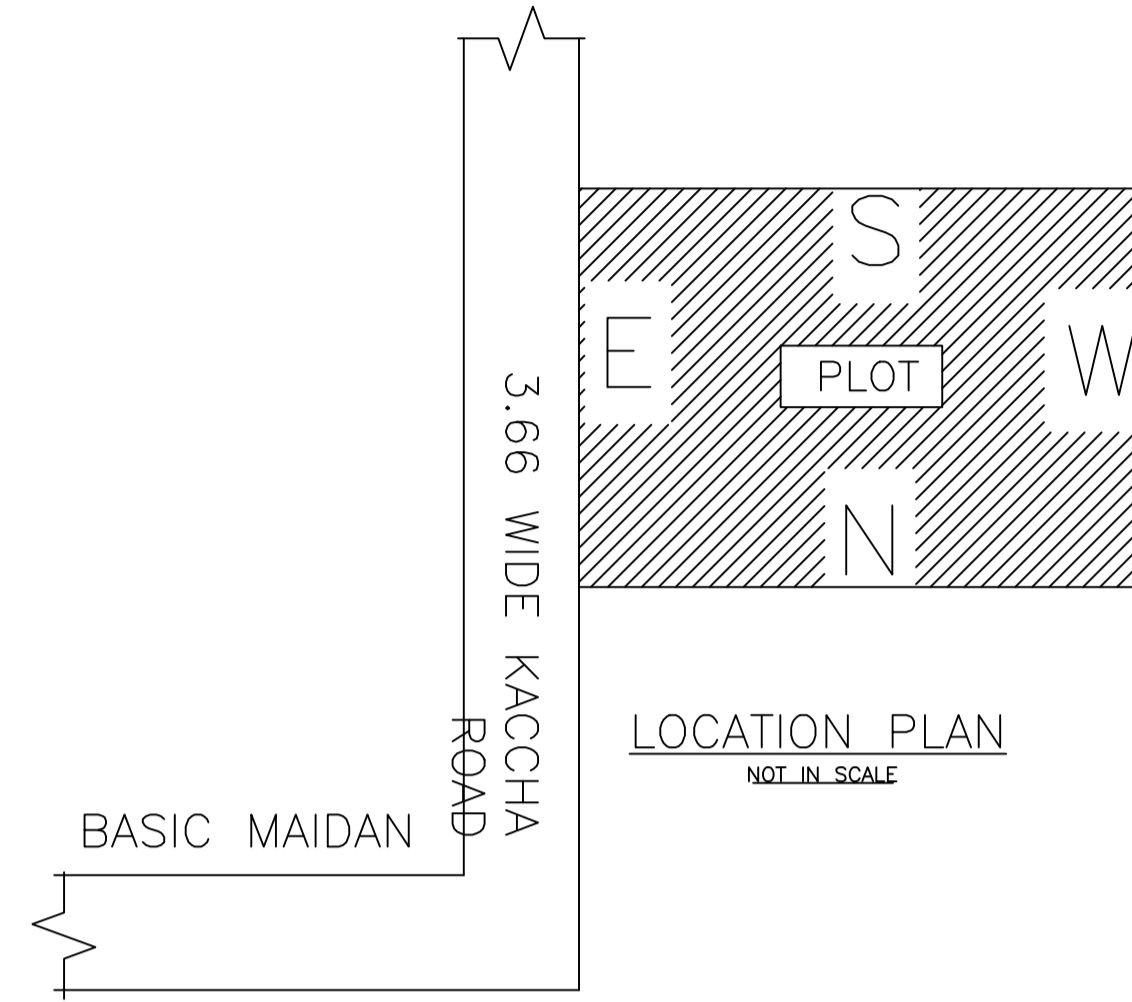

LOCATION PLAN  
NOT IN SCALE

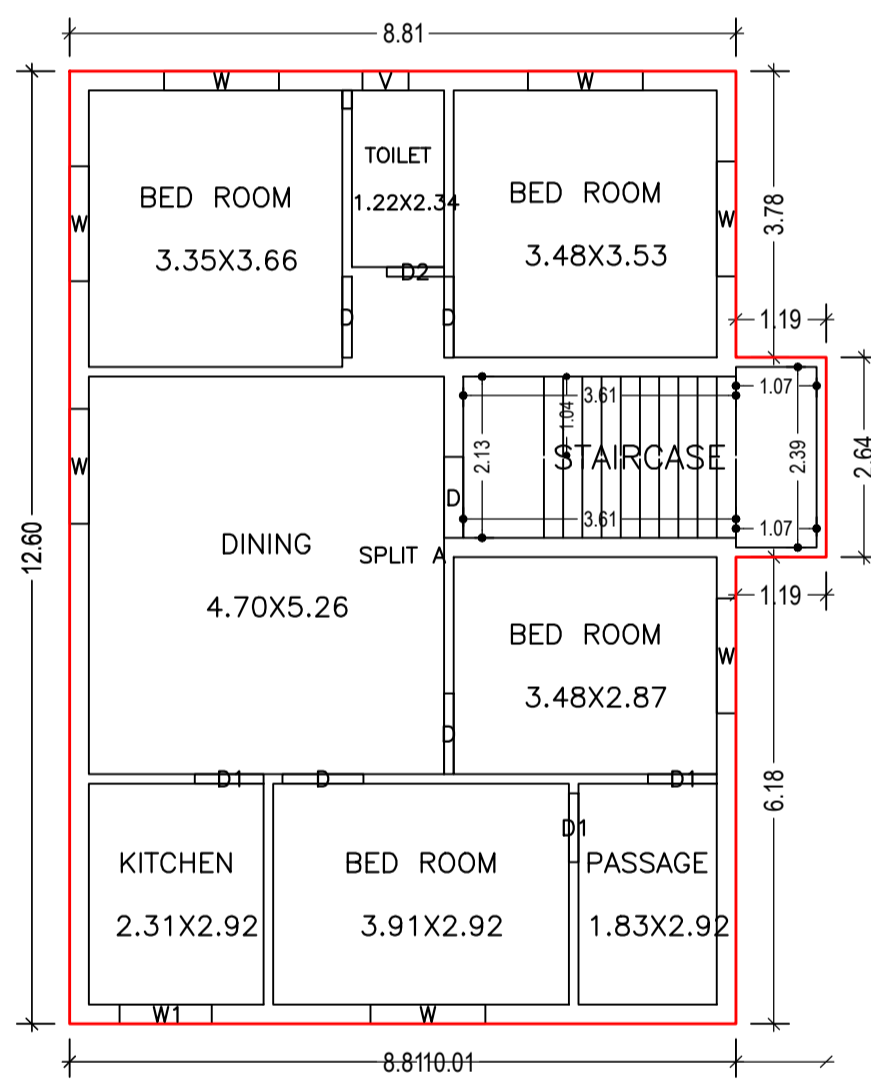

FIRST FLOOR PLAN  
(Proposed)  
(SCALE 1:100)

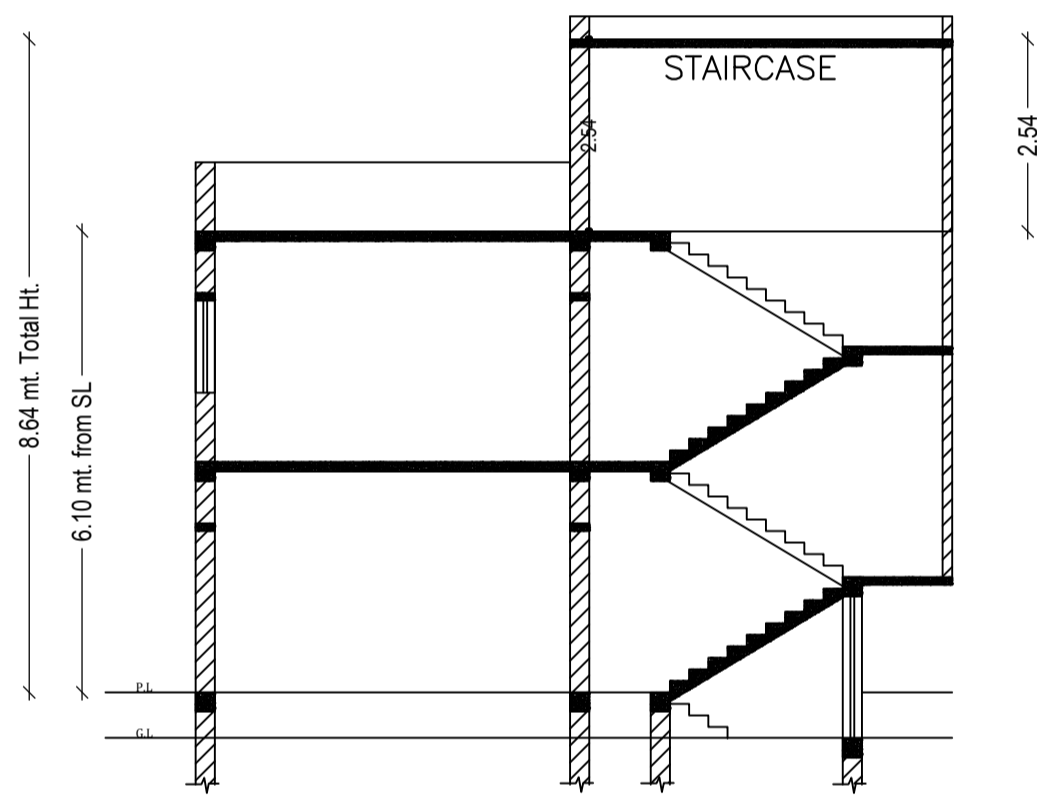

SECTION ON  
SCALE 1:100

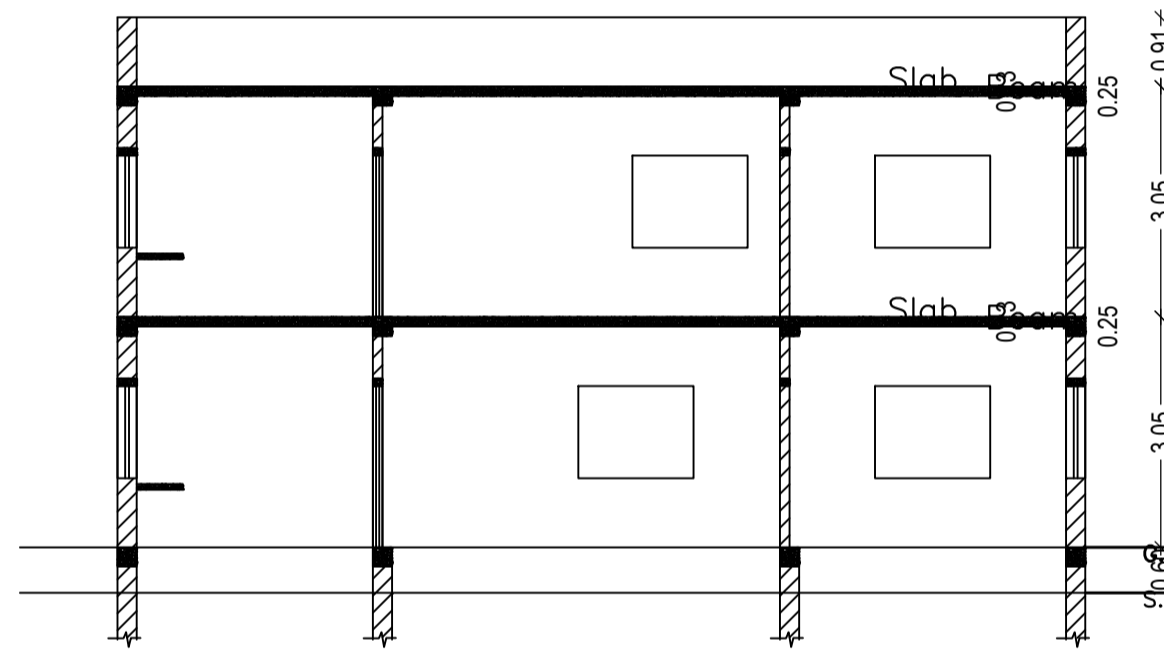

SECTION ON  
SCALE 1:100

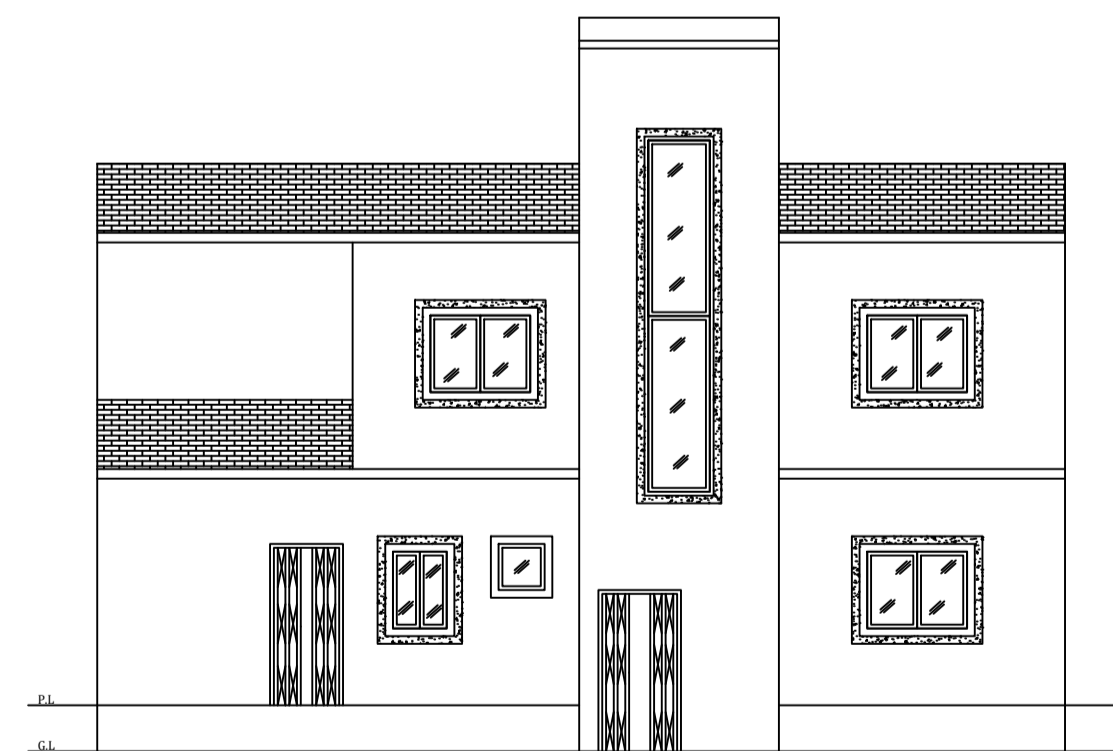

LEFT SIDE ELEVATION  
SCALE 1:100

Building :A (RESIDENCE)

Floor Name	Total Built Up Area (Sq.mt.)	Proposed FAR Area (Sq.mt.)	Total FAR Area (Sq.mt.)	Total Consumed Additional FAR Area (Sq.mt.)	Tnmt (No.)
Ground Floor	114.22	114.22	114.22	114.22	01
First Floor	114.22	114.22	114.22	114.22	00
Terrace Floor	0.00	0.00	0.00	0.00	00
Total:	228.44	228.44	228.44	228.44	01
Total Number of Same Buildings	1				
Total:	228.44	228.44	228.44	228.44	01

SCHEDULE OF DOOR:

BUILDING NAME	NAME	LENGTH	HEIGHT	NOS
A (RESIDENCE)	D2	0.76	2.10	03
A (RESIDENCE)	D1	0.91	2.10	04
A (RESIDENCE)	D	1.07	2.10	09
A (RESIDENCE)	GG	1.07	2.10	01

SCHEDULE OF WINDOW/VENTILATION:

BUILDING NAME	NAME	LENGTH	HEIGHT	NOS
A (RESIDENCE)	V	0.61	1.20	03
A (RESIDENCE)	W1	1.22	1.20	03
A (RESIDENCE)	W	1.52	1.20	13
A (RESIDENCE)	GW	1.52	1.20	01

UnitBUA Table for Building :A (RESIDENCE)

FLOOR	Name	UnitBUA Type	UnitBUA Area	Carpet Area	No. of Rooms	No. of Tenement
GROUND FLOOR PLAN	SPLIT A	FLAT	181.84	181.74	9	1
FIRST FLOOR PLAN	SPLIT A	FLAT	0.00	0.00	8	0
Total:	-	-	181.84	181.74	17	1

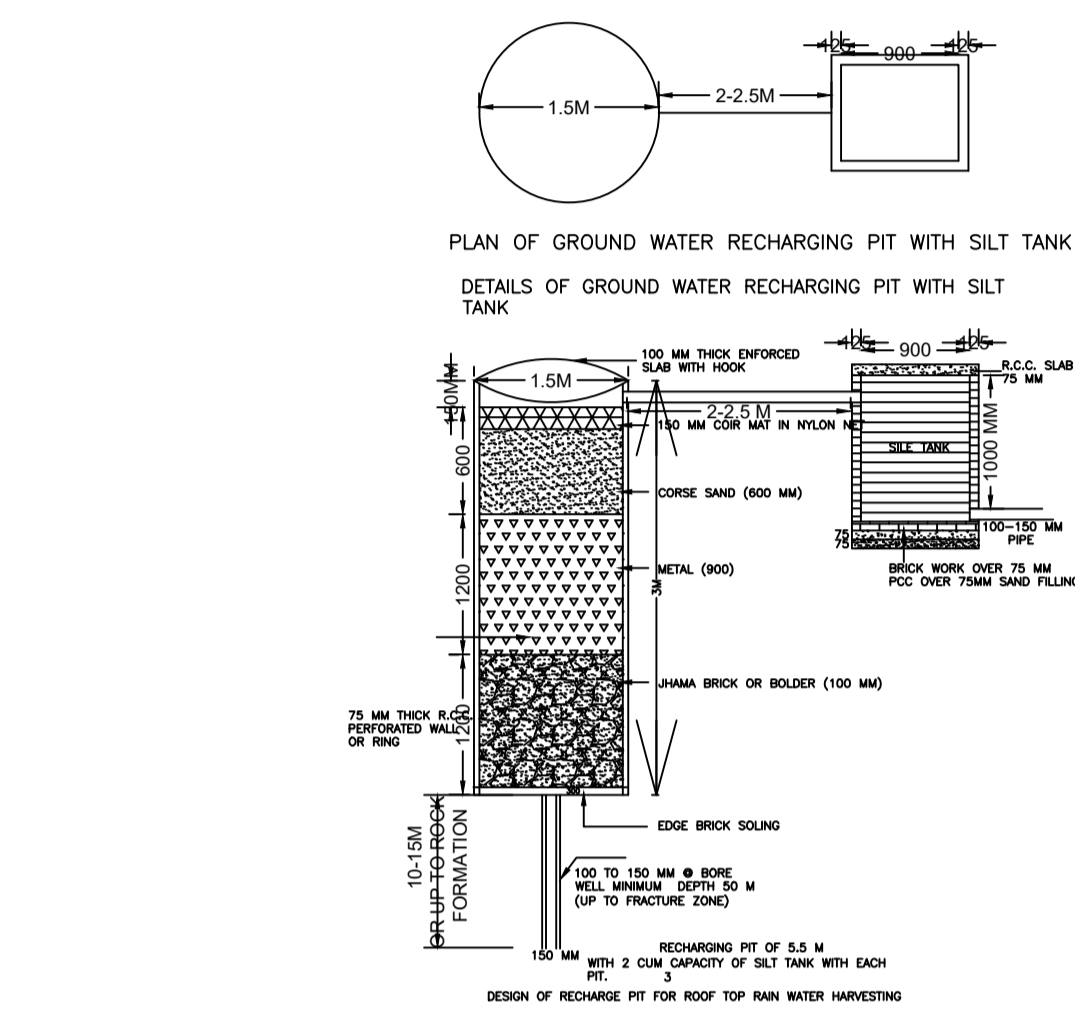

PLAN OF GROUND WATER RECHARGING PIT WITH SILT TANK  
DETAILS OF GROUND WATER RECHARGING PIT WITH SILT TANK

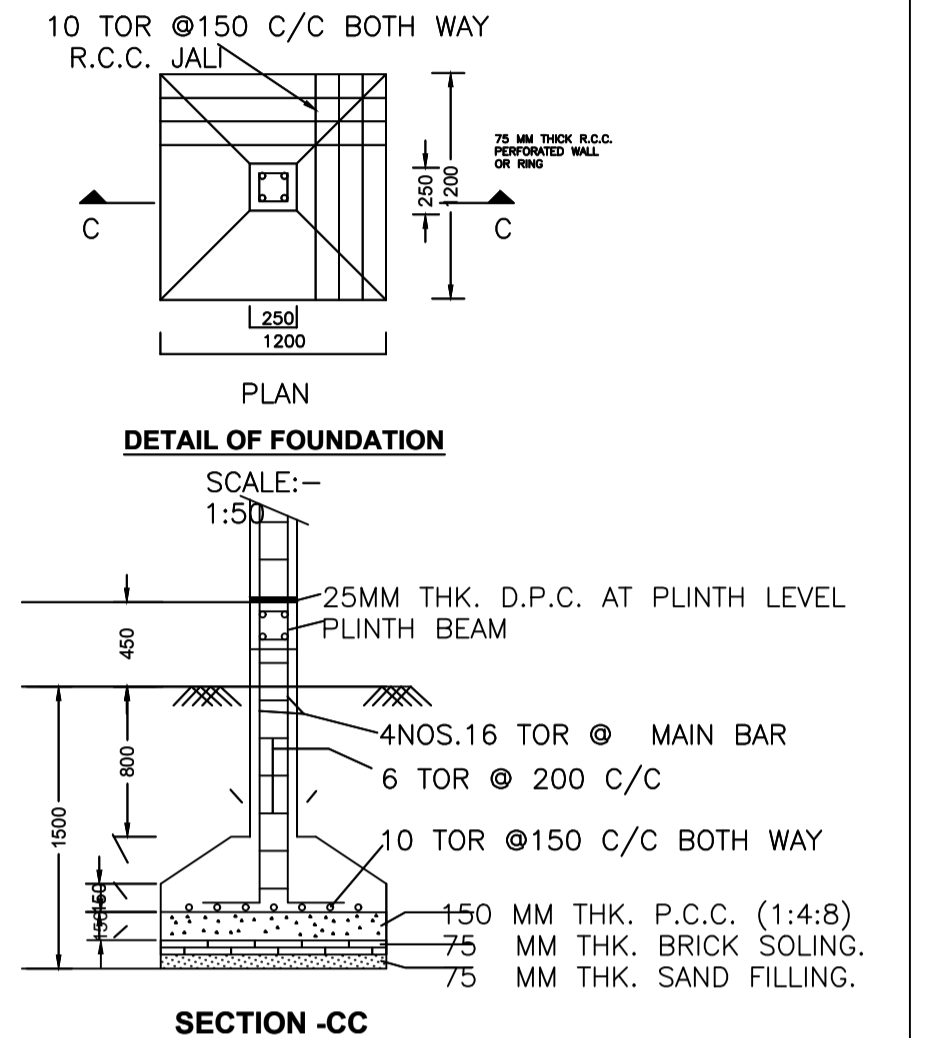

DETAIL OF FOUNDATION  
SCALE:- 1:50  
25MM THK. D.P.C. AT PLINTH LEVEL  
PLINTH BEAM  
4NOS.16 TOR @ MAIN BAR  
6 TOR @ 200 C/C  
10 TOR @150 C/C BOTH WAY  
150 MM THK. P.C.C. (1:4:8)  
75 MM THK. BRICK SOLING.  
75 MM THK. SAND FILLING.

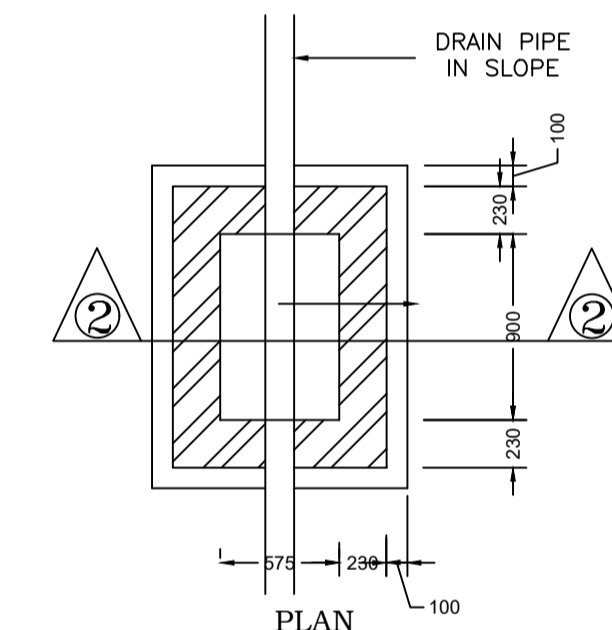

I.C. DETAILS

R.C.C. COVER

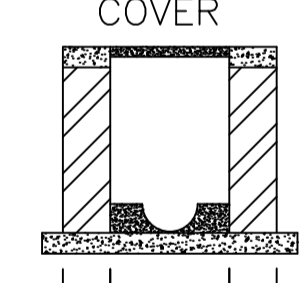

SECTION AT 2-2

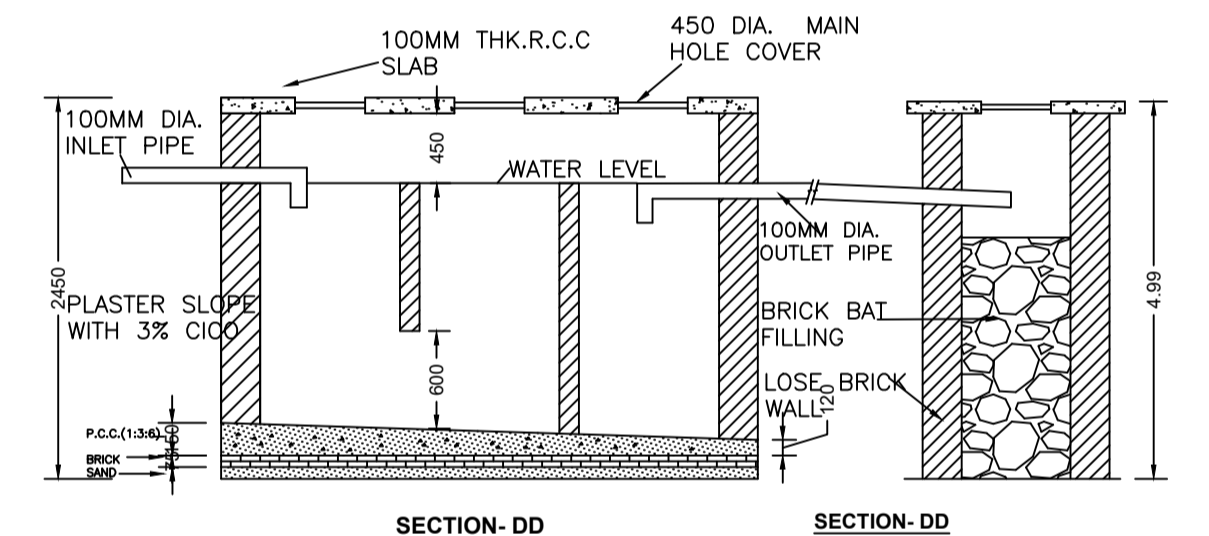

SECTION-DD

SECTION-DD

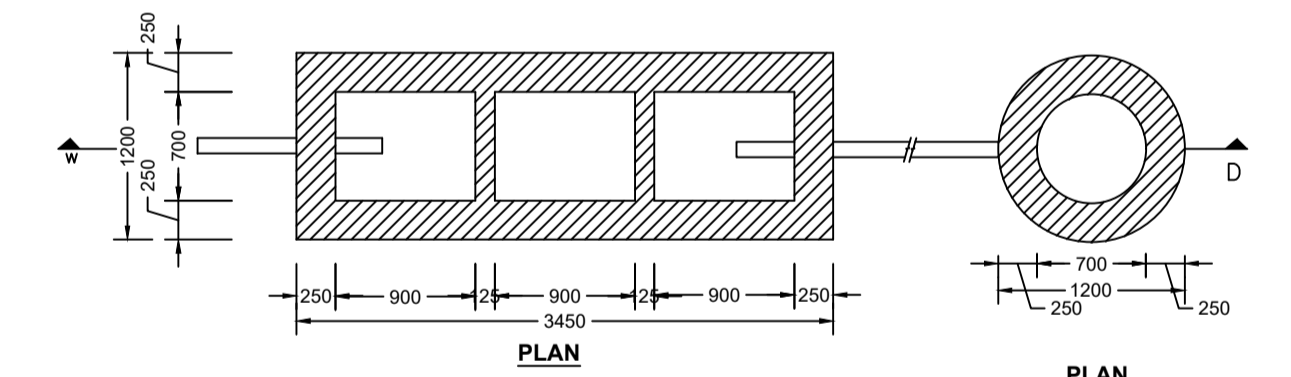

DETAIL OF SEPTIC TANK & SOAKPIT.

PLAN SCALE - 1:50

LTP NAME AND SIGNATURE	STRUCTURAL ENG'S NAME AND SIGNATURE	BUILDER NAME AND SIGNATURE	DIGITAL SIGNATURE
MAHENDRA MEHTA SINPC/DFTMN/0002/2022			

Proposal Basic Information

Proposal File No.	SINPC/SP/0439/W06/2023
Owner Name	RENU RANJITA KULLU
Khata No	113
Plot No	2490
Village Name	Khijri
Use	Residential
SubUse	Bungalow/ Dwelling / Non Apartment

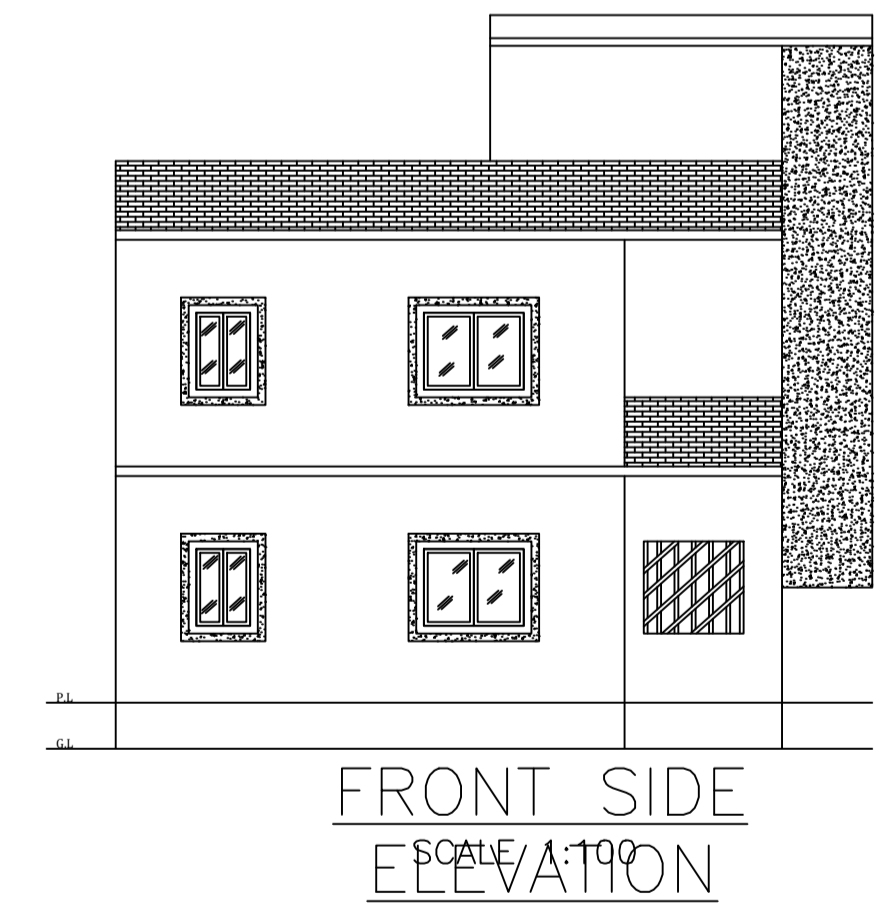
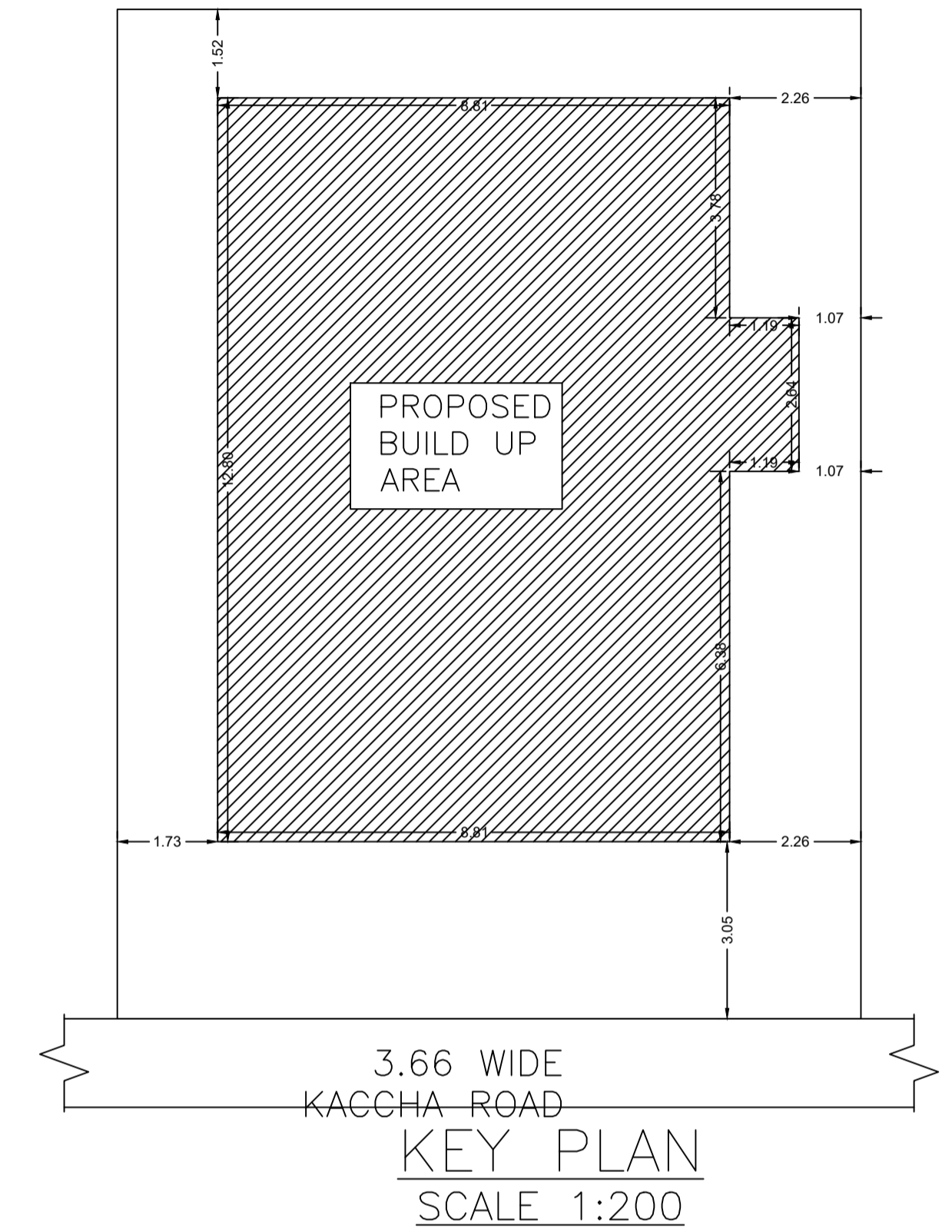

LTP NAME AND SIGNATURE	STRUCTURAL ENG'S NAME AND SIGNATURE	BUILDER NAME AND SIGNATURE	DIGITAL SIGNATURE
MAHENDRA MEHTA SINPC/DFTMN/0002/2022			