

SITE PLAN

FAR & Tenement Details (Table 4c-1)

Building	No. of Same Bldg	Total Built Up Area (Sq.mt.)	Proposed FAR Area (Sq.mt.) Resi.	Total FAR Area (Sq.mt.)	Total Consumed Additional FAR Area (Sq.mt.)	Tnmt (No.)
A1 (RESIDENCE)	1	263.28	263.28	263.28	263.28	01
Grand Total	1	263.28	263.28	263.28	263.28	01

Proposal Basic Information

Proposal File No.	SINPC/DP/0392/W03/2023
Owner Name	RANJANA SWATI KERKETTA
Khata No	62
Plot No	247
Village Name	Saldega
Use	Residential
SubUse	Bungalow/ Dwelling / Non Apartment

AREA STATEMENT SIMDEGA NAGAR PANCHAYAT	VERSION NO.: 1.0.66
PROJECT DETAIL	VERSION DATE: 16/10/2020
Region: JHARKHAND URBAN LOCAL BODIES	Plot Use: Residential
District: SIMDEGA	Plot SubUse: Bungalow/ Dwelling / Non Apartment
Authority: SIMDEGA NAGAR PANCHAYAT	PlotNearbyReligiousStructure: NA
Inward No: SINPC/DP/0392/W03/2023	Plot/SubPlot No: 247
Application Type: General Proposal	North: -
Project Type: Building Permission	South: -
Nature of Development: New	East: -
Location of Development Area: New Area	West: -
AREA DETAILS:	SQ.MT.
AREA OF PLOT (Minimum)	(A) 487.92
NET AREA OF PLOT(Gross Plot Area - Deduction from Gross Plot area)	(A-Deductions) 487.92
Deduction for Balance Plot Area(from Gross Plot Area)	
Common Plot	33.50
Total	33.50
BALANCE AREA OF PLOT(Net Plot Area - Recreational/Amenity space)	(A-Deductions) 454.43
PLOT AREA FOR COVERAGE(Net Plot Area)	(A-Deductions) 487.92
Plot Area for FAR (Net Plot Area + RoadWidening Area)	(A-Deductions) 487.92
COVERAGE CHECK	
Permissible Coverage area (60.00 %)	292.75
Proposed Coverage Area (26.98 %)	131.64
Total Prop. Coverage Area (26.98 %)	131.64
Balance coverage area (33.02 %)	161.11
FAR CHECK	
Perm. FAR Area (1.500)	731.88
Total Perm. FAR area	731.88
Residential FAR	263.27
Proposed FAR Area	263.27
Total Proposed FAR Area	263.27
Consumed FAR (Factor)	0.54
Balance FAR Area	468.61
BUILT UP AREA CHECK	
Total Proposed BuiltUp Area	263.28
ARCHITECT (Regd)	MAHENDRA MEHTA
ENGINEER (Regd)	
SUPERVISOR (Regd)	
OWNER (Regd)	RANJANA SWATI KERKETTA
DEVELOPMENT AUTHORITY	LOCAL BODY

COLOR INDEX	
PLOT BOUNDARY	Black
ABUTTING ROAD	Green
PROPOSED CONSTRUCTION	Red
COMMON PLOT	Yellow
ROAD WIDENING AREA	Orange
EXISTING (To be retained)	Blue
EXISTING (To be demolished)	Light Blue

Buildingwise Floor FAR Details

Floor Name	Building Name A1 (RESIDENCE)		Total	
	Proposed Built Up Area (Sq.mt.)	Proposed FAR Area (Sq.mt.)	Total Proposed Built Up Area (Sq.mt.)	Total FAR Area (Sq.mt.)
Ground Floor	131.64	131.64	131.64	131.64
First Floor	131.64	131.64	131.64	131.64
Terrace Floor	0.00	0.00	0.00	0.00
Total	263.28	263.28	263.28	263.28

Building USE/SUBUSE Details

Building Name	Building Use	Building SubUse	Building Structure
A1 (RESIDENCE)	Residential	Bungalow/ Dwelling / Non Apartment	Non-Highrise

LTP NAME AND SIGNATURE	STRUCTURAL ENG'S NAME AND SIGNATURE	BUILDER NAME AND SIGNATURE	DIGITAL SIGNATURE
MAHENDRA MEHTA SINPC/DFTMN/0002/2022			

Proposal Basic Information	
Proposal File No.	SINPC/0392/W03/2023
Owner Name	RANJANA SWATI KERKETTA
Khata No	62
Plot No	247
Village Name	Saldega
Use	Residential
SubUse	Bungalow/ Dwelling / Non Apartment

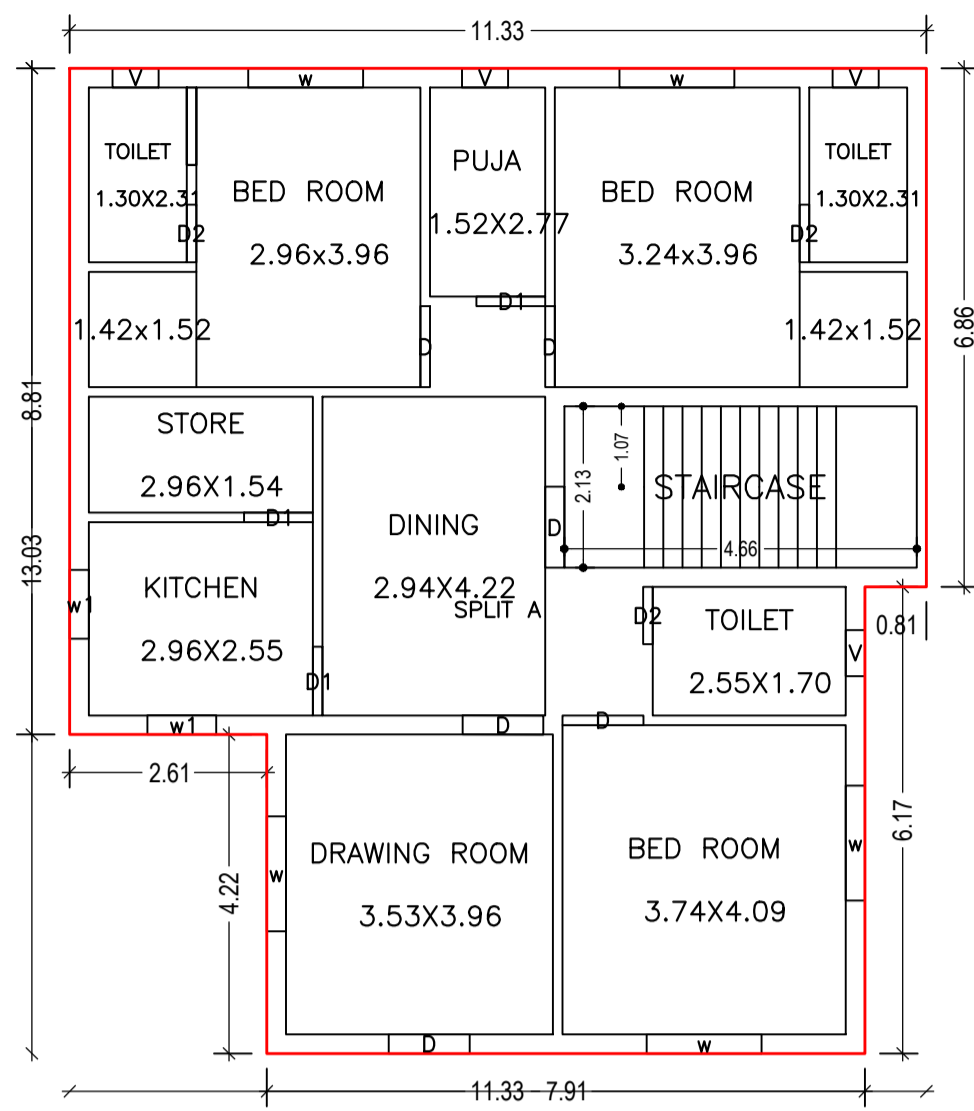

GROUND FLOOR PLAN (Proposed) (SCALE 1:100)

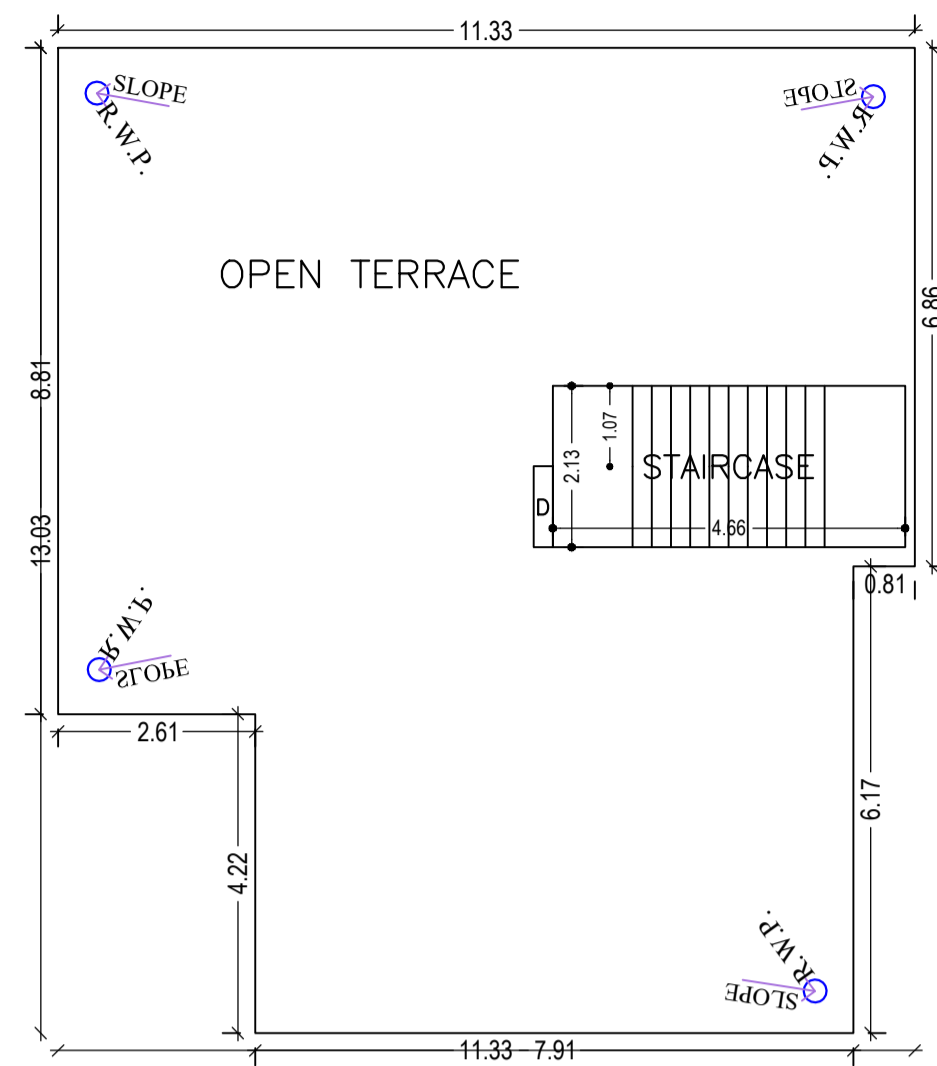

TERRACE FLOOR PLAN (SCALE 1:100)

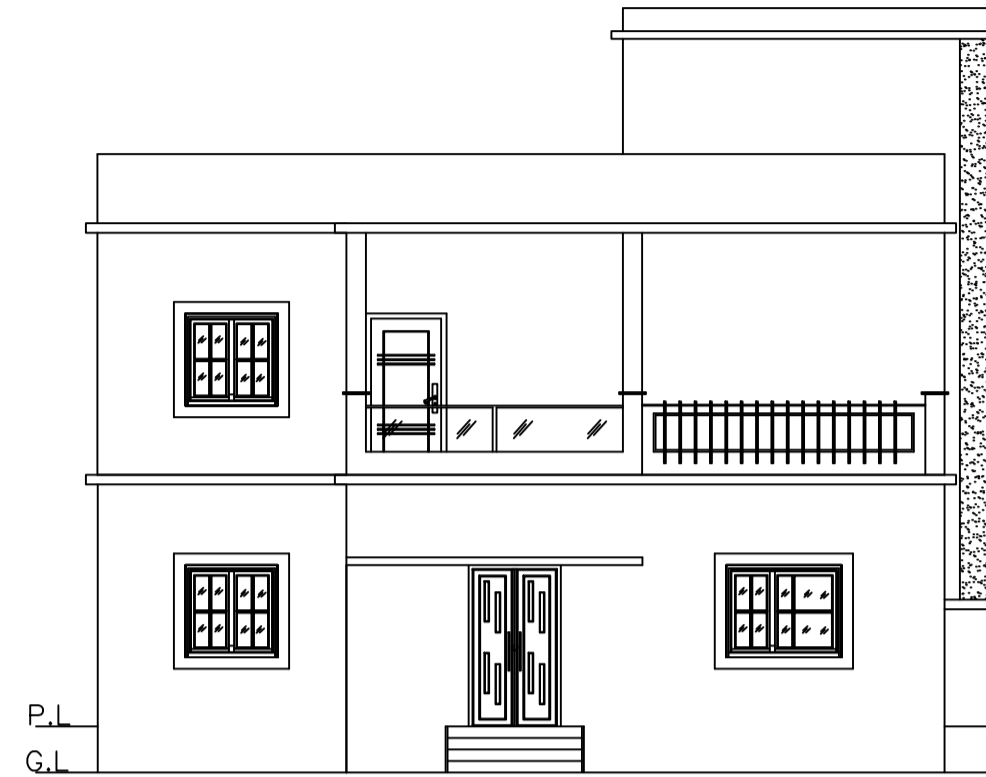

FRONT ELEVATION

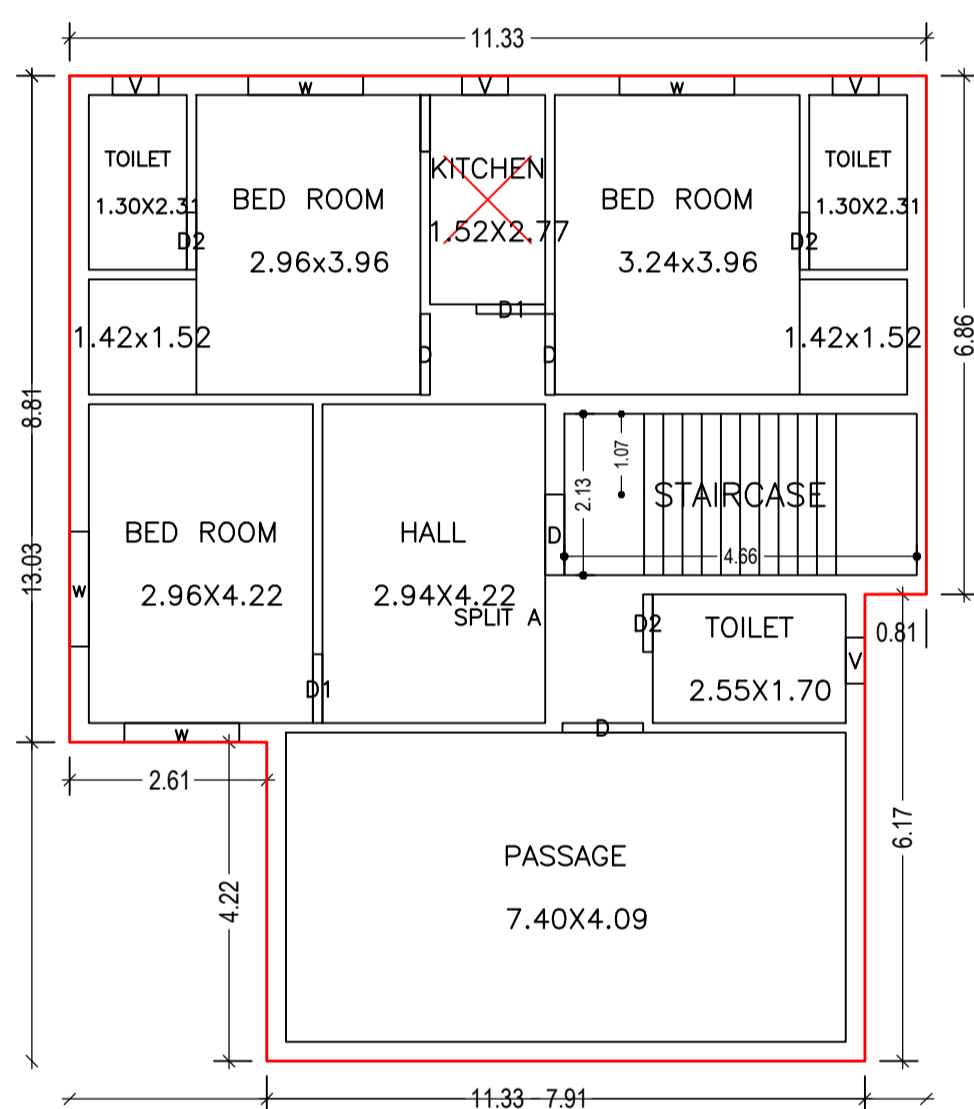

FIRST FLOOR PLAN (Proposed) (SCALE 1:100)

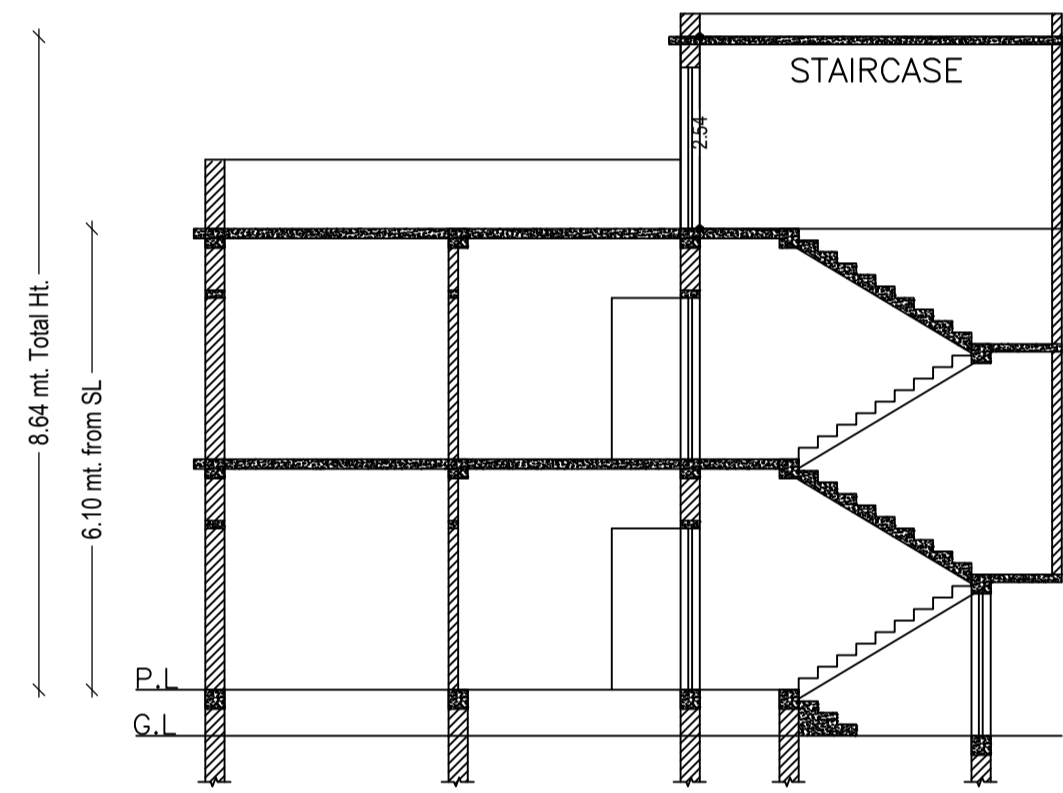

SECTION ON (SCALE 1:100)

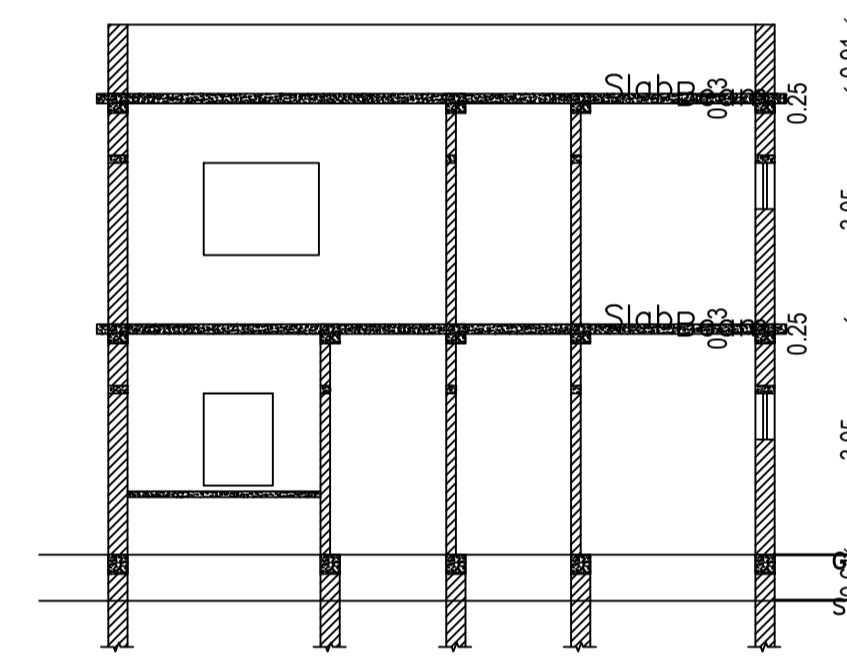

SECTION ON (SCALE 1:100)

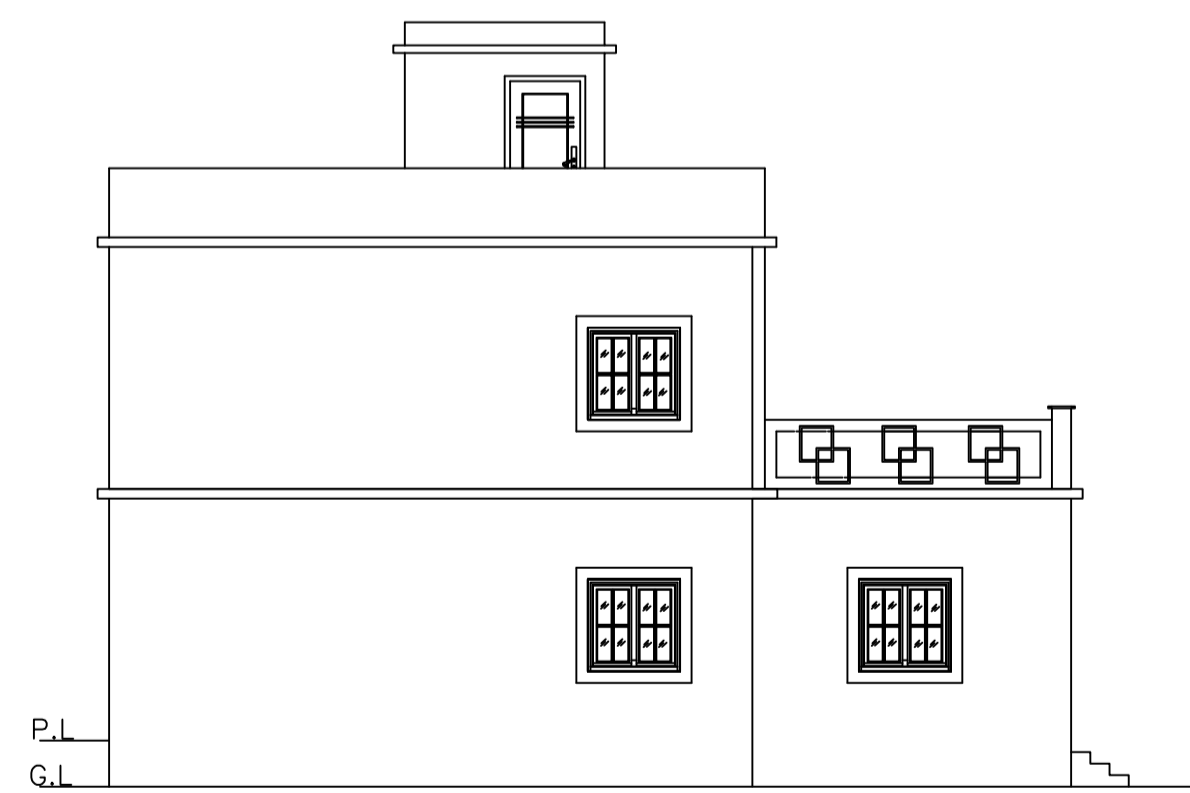

LEFT SIDE ELEVATION

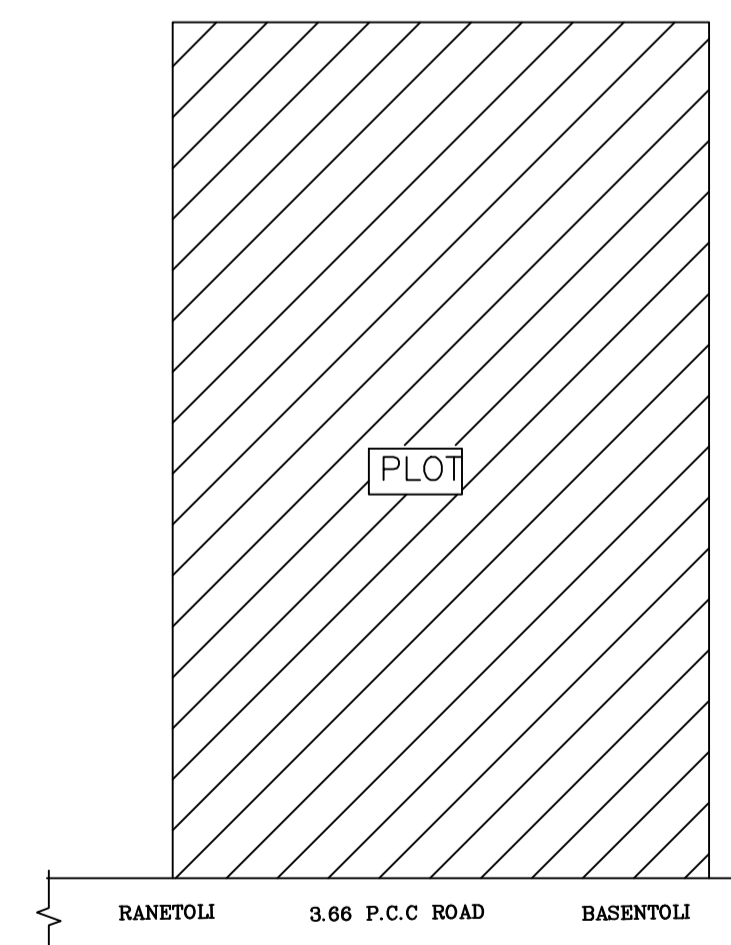

LOCATION PLAN (NOT IN SCALE)

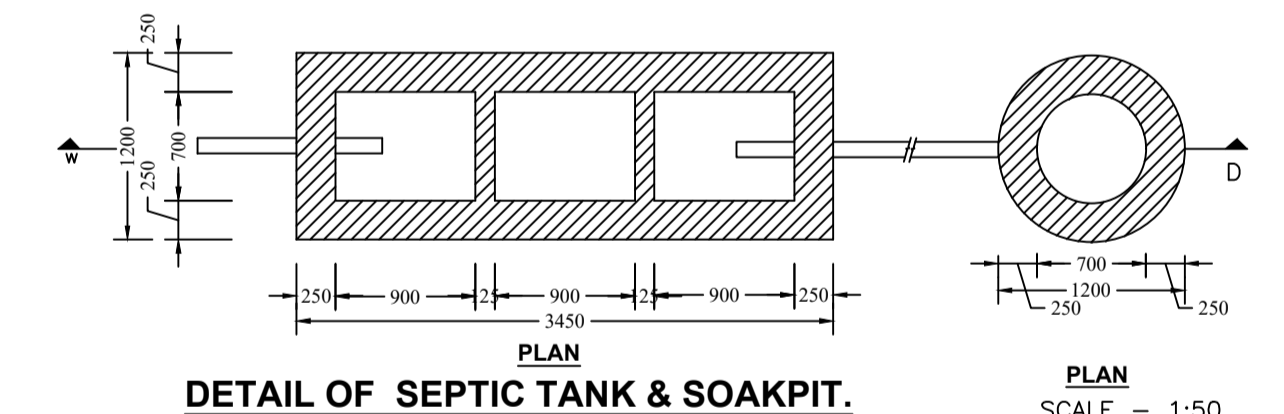
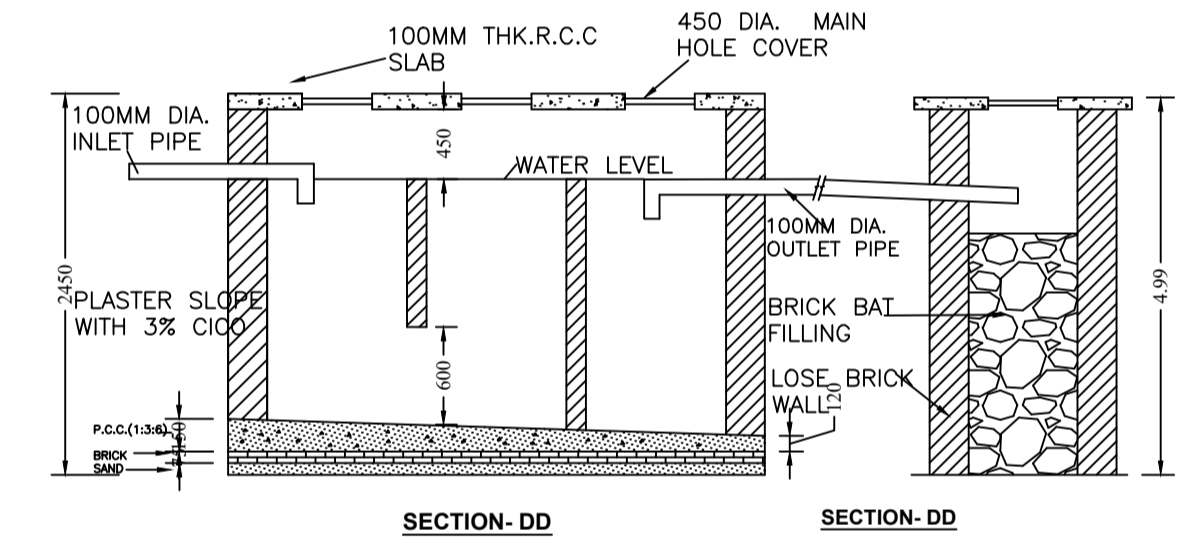
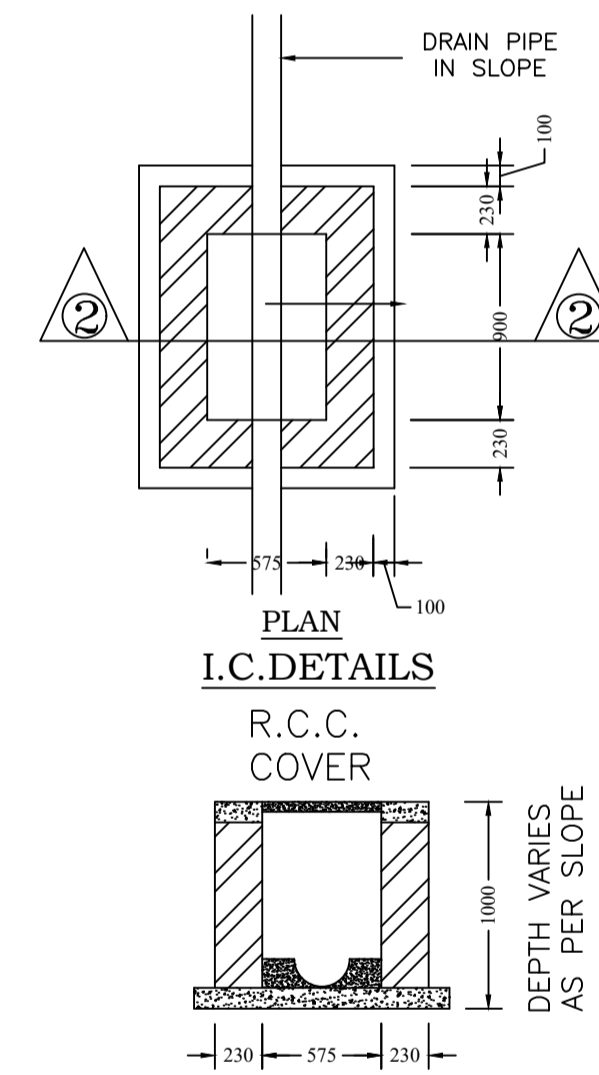
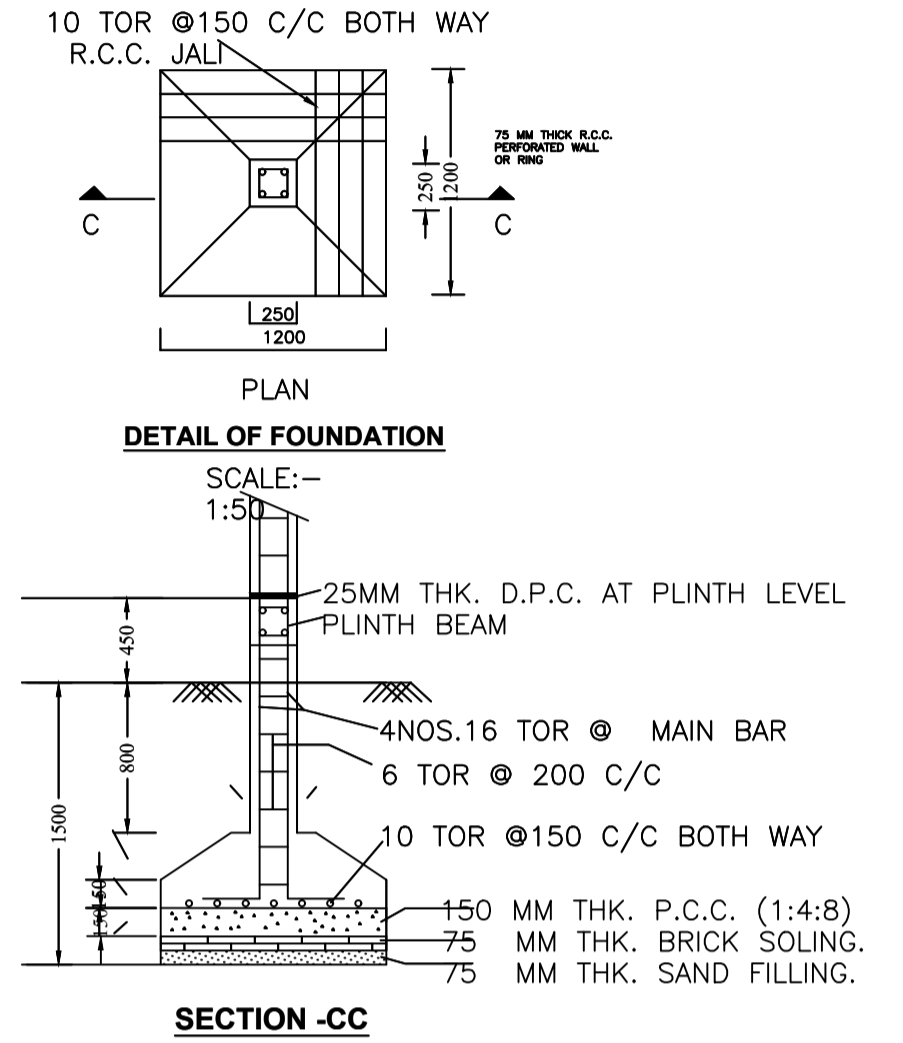
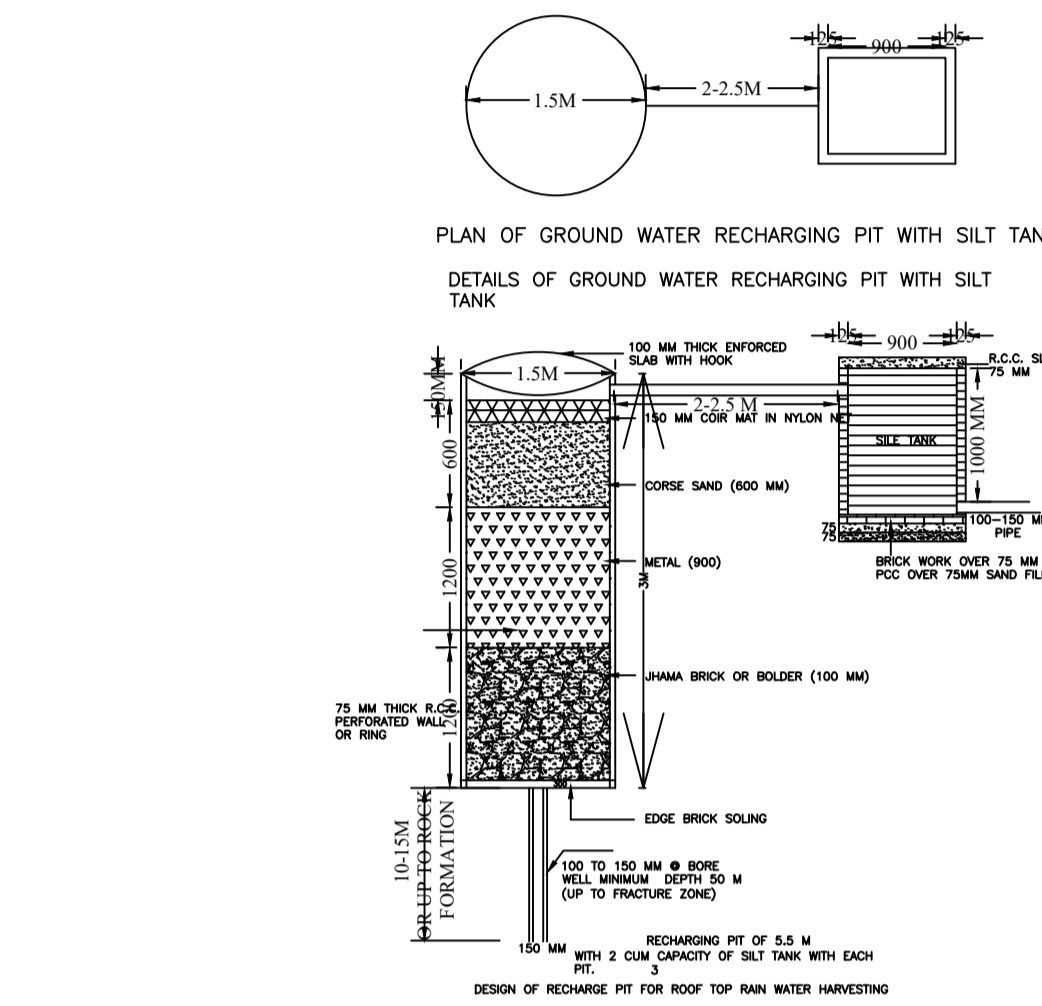

Building :A1 (RESIDENCE)

Floor Name	Total Built Up Area (Sq.mt.)	Proposed FAR Area (Sq.mt.)	Total FAR Area (Sq.mt.)	Total Consumed Additional FAR Area (Sq.mt.)	Tnmt (No.)
Ground Floor	131.64	131.64	131.64	131.64	01
First Floor	131.64	131.64	131.64	131.64	00
Terrace Floor	0.00	0.00	0.00	0.00	00
Total:	263.28	263.28	263.28	263.28	01
Total Number of Same Buildings	1				
Total:	263.28	263.28	263.28	263.28	01

SCHEDULE OF DOOR:

BUILDING NAME	NAME	LENGTH	HEIGHT	NOS
A1 (RESIDENCE)	D2	0.76	2.10	06
A1 (RESIDENCE)	D1	0.91	2.10	05
A1 (RESIDENCE)	D	1.07	2.10	10

SCHEDULE OF WINDOW/VENTILATION:

BUILDING NAME	NAME	LENGTH	HEIGHT	NOS
A1 (RESIDENCE)	v	0.61	1.20	08
A1 (RESIDENCE)	w1	0.91	1.20	02
A1 (RESIDENCE)	w	1.52	1.20	09

UnitBUA Table for Building :A1 (RESIDENCE)

FLOOR	Name	UnitBUA Type	UnitBUA Area	Carpet Area	No. of Rooms	No. of Tenement
GROUND FLOOR PLAN	SPLIT A	FLAT	213.94	213.71	11	1
FIRST FLOOR PLAN	SPLIT A	FLAT	0.00	0.00	9	0
Total:	-	-	213.94	213.71	20	1

LTP NAME AND SIGNATURE	STRUCTURAL ENG'S NAME AND SIGNATURE	BUILDER NAME AND SIGNATURE	DIGITAL SIGNATURE
MAHENDRA MEHTA SINPC/DFTMN/0002/2022			

Proposal Basic Information

Proposal File No.	SINPC/SP/0392/W03/2023
Owner Name	RANJANA SWATI KERKETTA
Khata No	62
Plot No	247
Village Name	Saldega
Use	Residential
SubUse	Bungalow/ Dwelling / Non Apartment

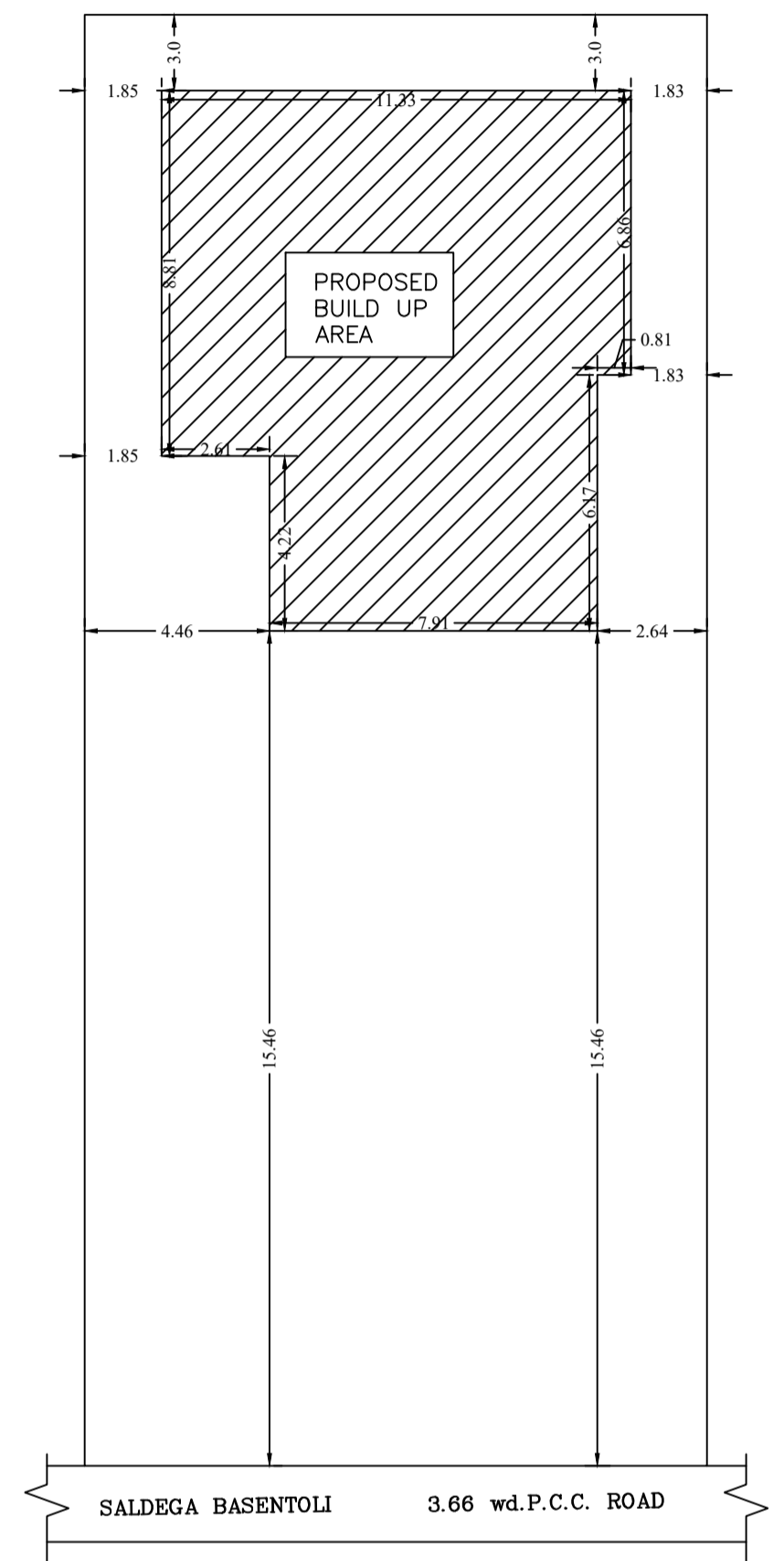

KEY PLAN
SCALE 1:200

LTP NAME AND SIGNATURE	STRUCTURAL ENG'S NAME AND SIGNATURE	BUILDER NAME AND SIGNATURE	DIGITAL SIGNATURE
MAHENDRA MEHTA SINPC/DFTMN/0002/2022			