

SITE PLAN
(Scale - 1:200)

FAR & Tenement Details (Table 4c-1)

Building	No. of Same Bldg	Total Built Up Area (Sq.mt.)	Proposed FAR Area (Sq.mt.) Resi.	Total FAR Area (Sq.mt.)	Total Consumed Additional FAR Area (Sq.mt.)	Tnmt (No.)
A (RESIDENTIAL)	1	289.09	289.09	289.09	289.09	01
Grand Total :	1	289.09	289.09	289.09	289.09	01

Proposal Basic Information

Proposal File No.	SINPC/BP/0411/W01/2023
Owner Name	LUCIA BILUNG
Khata No	268
Plot No	3132
Village Name	Gotra
Use	Residential
SubUse	Bungalow/ Dwelling / Non Apartment

AREA STATEMENT SIMDEGA NAGAR PANCHAYAT		VERSION NO: 1.0.66
PROJECT DETAIL:		VERSION DATE: 16/10/2020
Region: JHARKHAND URBAN LOCAL BODIES	Plot Use: Residential	
District: SIMDEGA	Plot SubUse: Bungalow/ Dwelling / Non Apartment	
Authority: SIMDEGA NAGAR PANCHAYAT	PlotNearbyReligiousStructure: NA	
Inward No: SINPC/BP/0411/W01/2023	PlotSubPlot No: 3132	
Application Type: General Proposal	North: -	
Project Type: Building Permission	South: -	
Nature of Development: New	East: -	
Location of Development Area: Old Area	West: -	
AREA DETAILS:		
AREA OF PLOT (Minimum)	(A)	SQ.MT. 647.16
Deduction for NetPlot Area		
Surrender Free of Cost		9.26
Total		9.26
NET AREA OF PLOT(Gross Plot Area - Deduction from Gross Plot area)		
(A-Deductions)		637.90
Deduction for Balance Plot Area(from Gross Plot Area)		
Surrender Free of Cost		9.26
Common Plot		36.06
Total		45.32
BALANCE AREA OF PLOT(Net Plot Area - Recreational/Amenity space)	(A-Deductions)	601.84
PLOT AREA FOR COVERAGE(Net Plot Area)	(A-Deductions)	637.90
Plot Area for FAR (Net Plot Area + RoadWidening Area)	(A-Deductions)	647.16
COVERAGE CHECK		
Permissible Coverage area (60.00 %)		382.74
Proposed Coverage Area (21.47 %)		136.96
Total Prop. Coverage Area (21.47 %)		136.96
Balance coverage area (38.53 %)		245.78
FAR CHECK		
Perm. FAR Area (1.500)		970.74
Total Perm. FAR area		970.74
Residential FAR		289.09
Proposed FAR Area		289.09
Total Proposed FAR Area		289.09
Consumed FAR (Factor)		0.45
Balance FAR Area		681.65
BUILT UP AREA CHECK		
Total Proposed BuiltUp Area		289.09
ARCHITECT (Regd)	MAHENDRA MEHTA	
ENGINEER (Regd)		
SUPERVISOR (Regd)		
OWNER (Regd)	LUCIA BILUNG	
DEVELOPMENT AUTHORITY		LOCAL BODY

COLOR INDEX	
PLOT BOUNDARY	Black
ABUTTING ROAD	Green
PROPOSED CONSTRUCTION	Red
COMMON PLOT	Yellow
ROAD WIDENING AREA	Blue
EXISTING (To be retained)	Blue
EXISTING (To be demolished)	Yellow

Buildingwise Floor FAR Details

Floor Name	Building Name A (RESIDENTIAL)		Total	
	Proposed Built Up Area (Sq.mt.)	Proposed FAR Area (Sq.mt.)	Total Proposed Built Up Area (Sq.mt.)	Total FAR Area (Sq.mt.)
Ground Floor	136.96	136.96	136.96	136.96
First Floor	152.13	152.13	152.13	152.13
Terrace Floor	0.00	0.00	0.00	0.00
Total :	289.09	289.09	289.09	289.09

Building USE/SUBUSE Details

Building Name	Building Use	Building SubUse	Building Structure
A (RESIDENTIAL)	Residential	Bungalow/ Dwelling / Non Apartment	Non-Highrise

LTP NAME AND SIGNATURE	STRUCTURAL ENG'S NAME AND SIGNATURE	BUILDER NAME AND SIGNATURE	DIGITAL SIGNATURE
MAHENDRA MEHTA SINPC/DFTMN/0002/2022			

Proposal Basic Information

Proposal File No.	SINPC/BP/0411/W01/2023
Owner Name	LUCIA BILUNG
Khata No	268
Plot No	3132
Village Name	Gotra
Use	Residential
SubUse	Bungalow/ Dwelling / Non Apartment

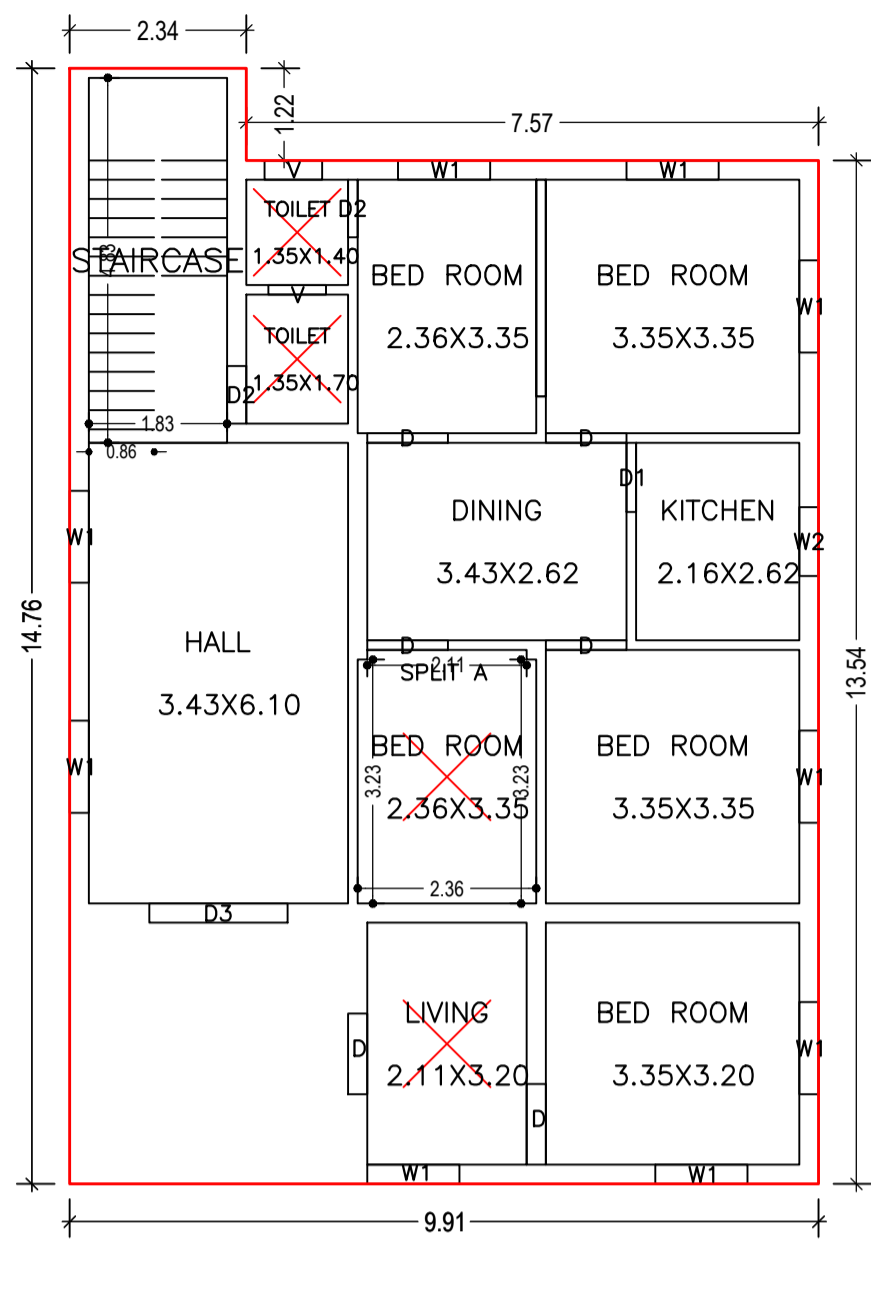

GROUND FLOOR PLAN (Proposed) (SCALE 1:100)

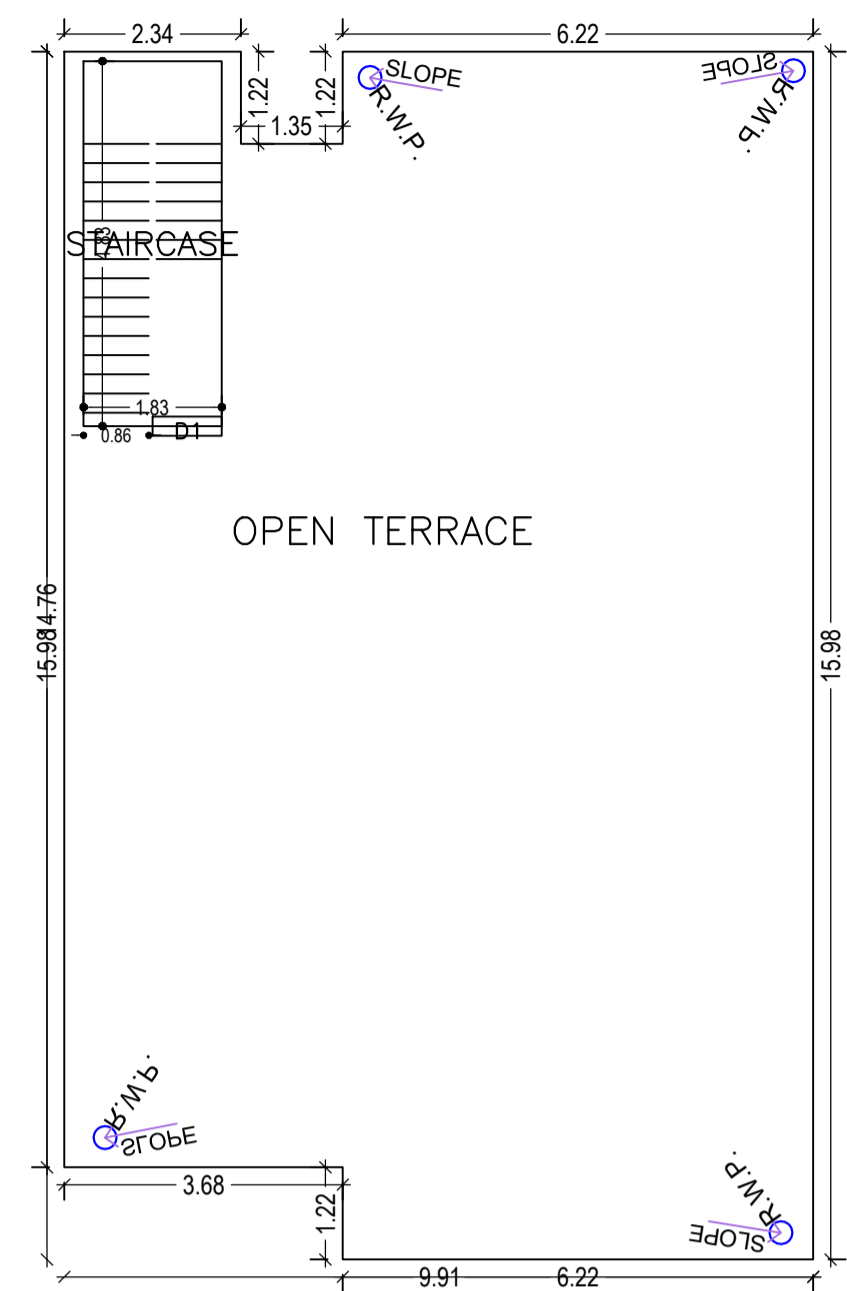

TERRACE FLOOR PLAN (SCALE 1:100)

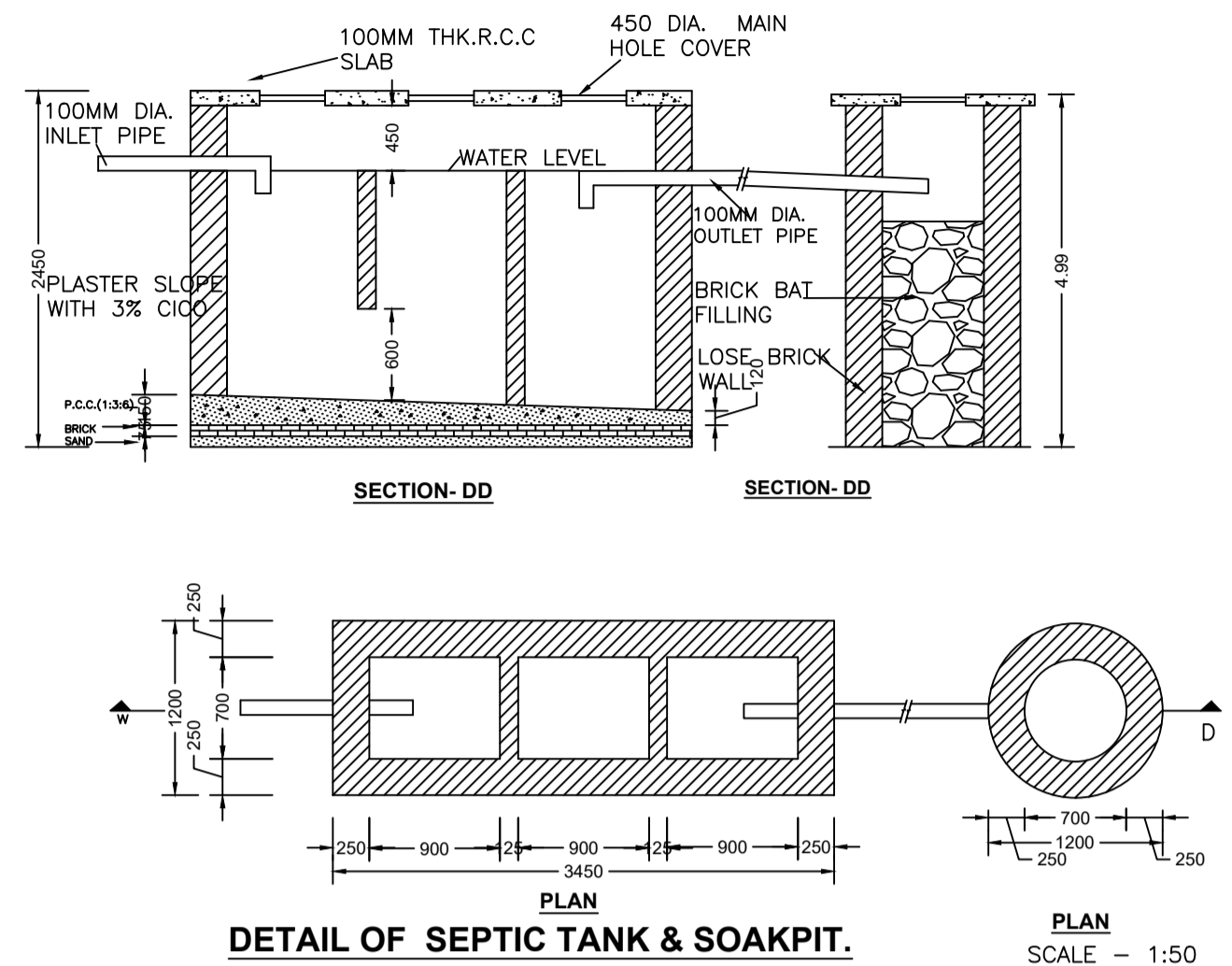

DETAIL OF SEPTIC TANK & SOAKPIT. PLAN SCALE - 1:50

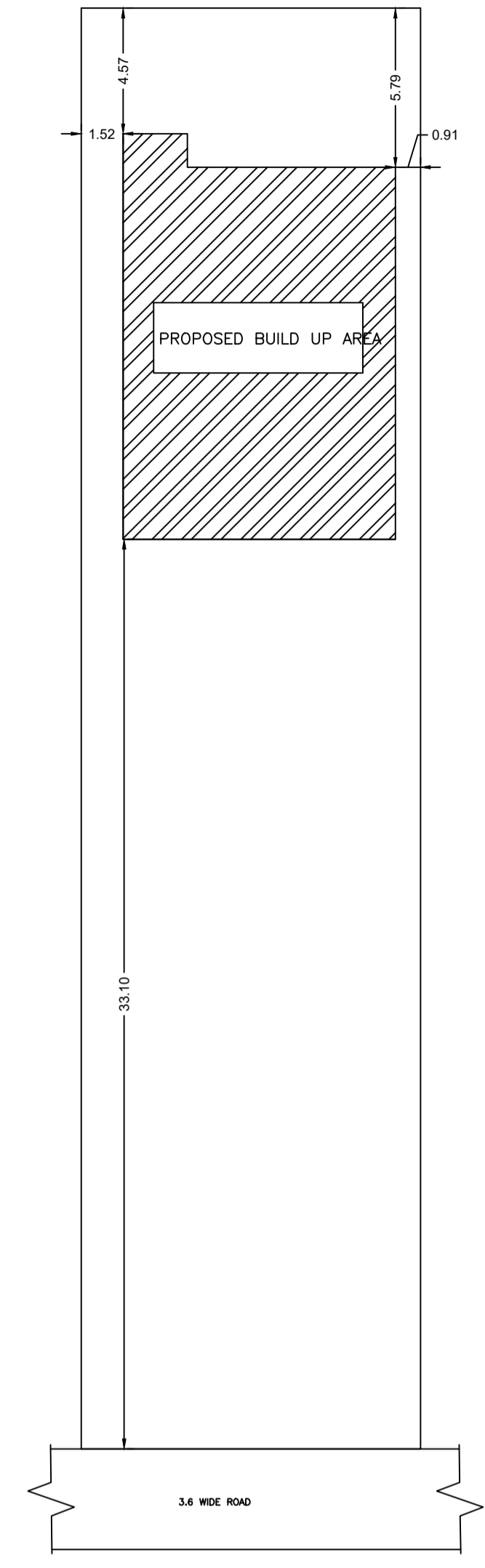

KEY PLAN SCALE 1:200



FRONT ELEVATION SCALE 1:100

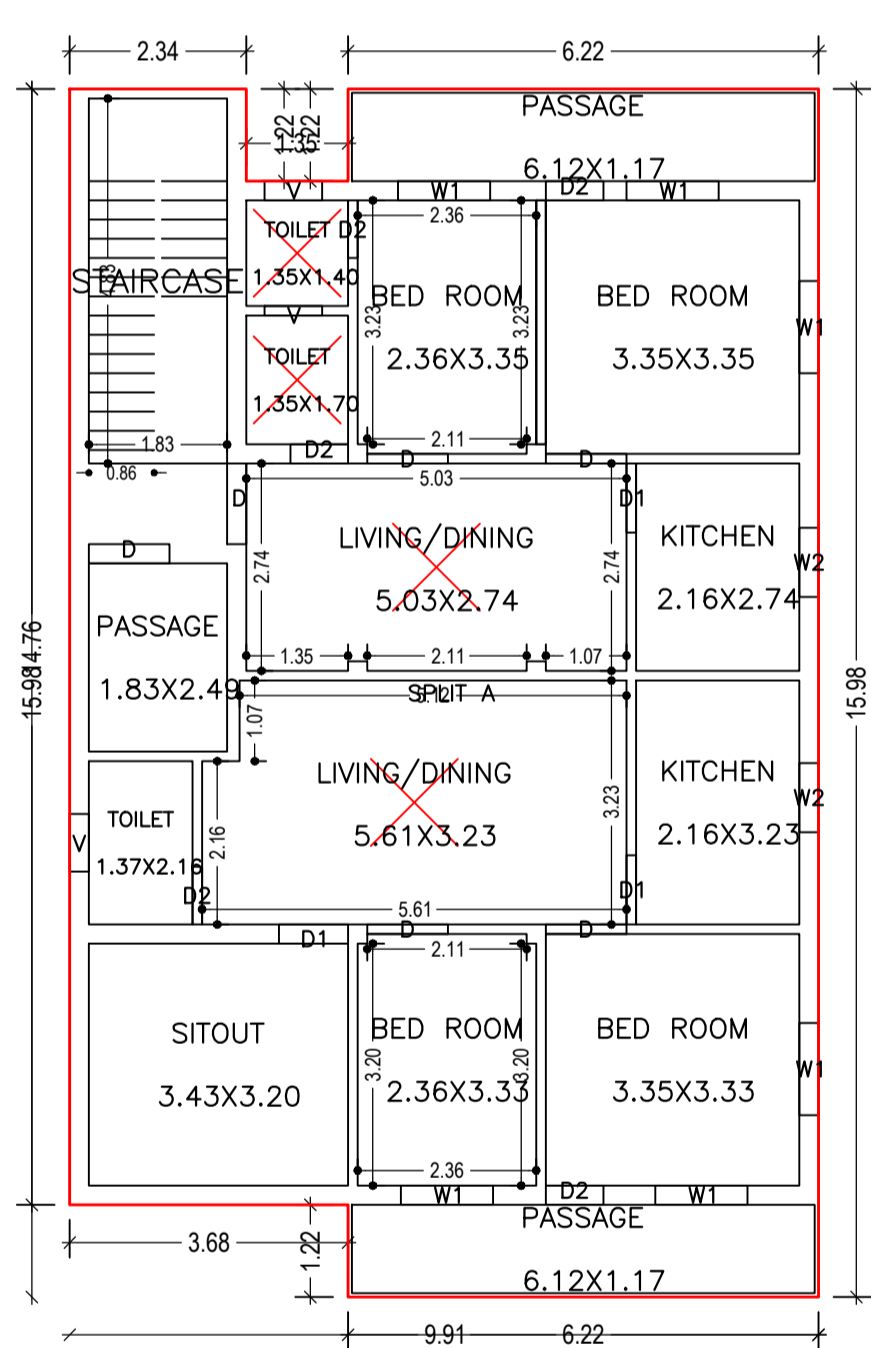

FIRST FLOOR PLAN (Proposed) (SCALE 1:100)

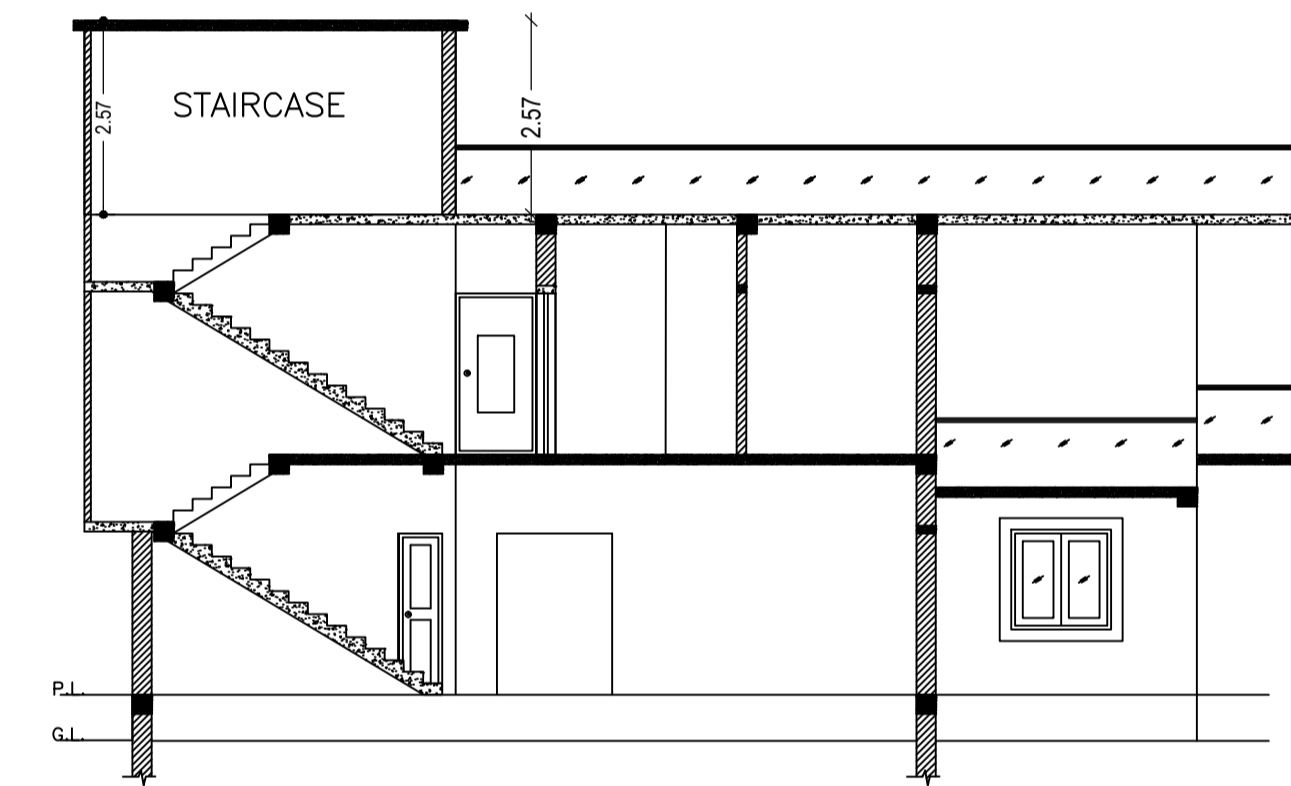

SECTION ON SCALE 1:100

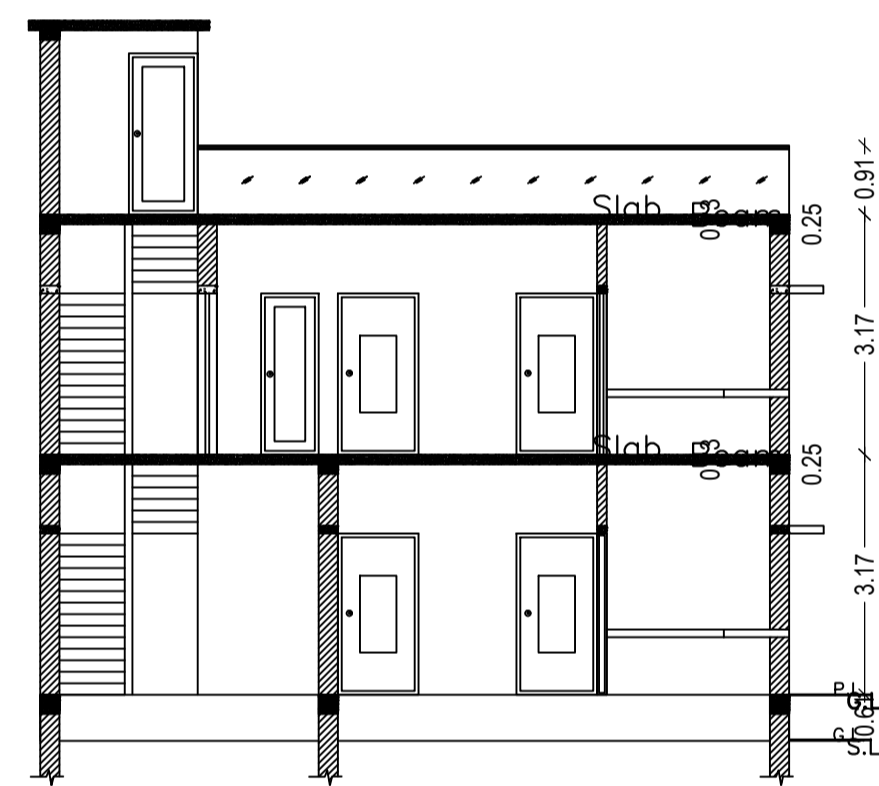

SECTION ON SCALE 1:100

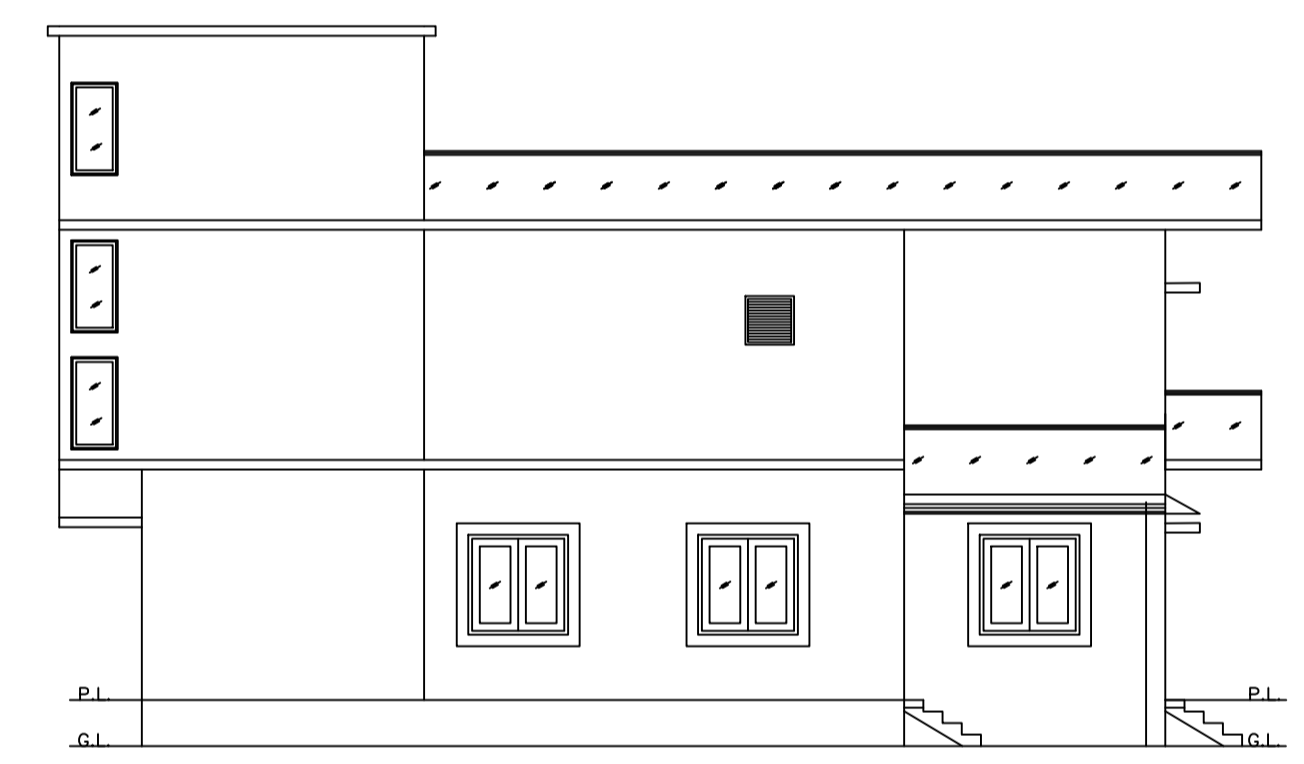

LEFT SIDE ELEVATION SCALE 1:100

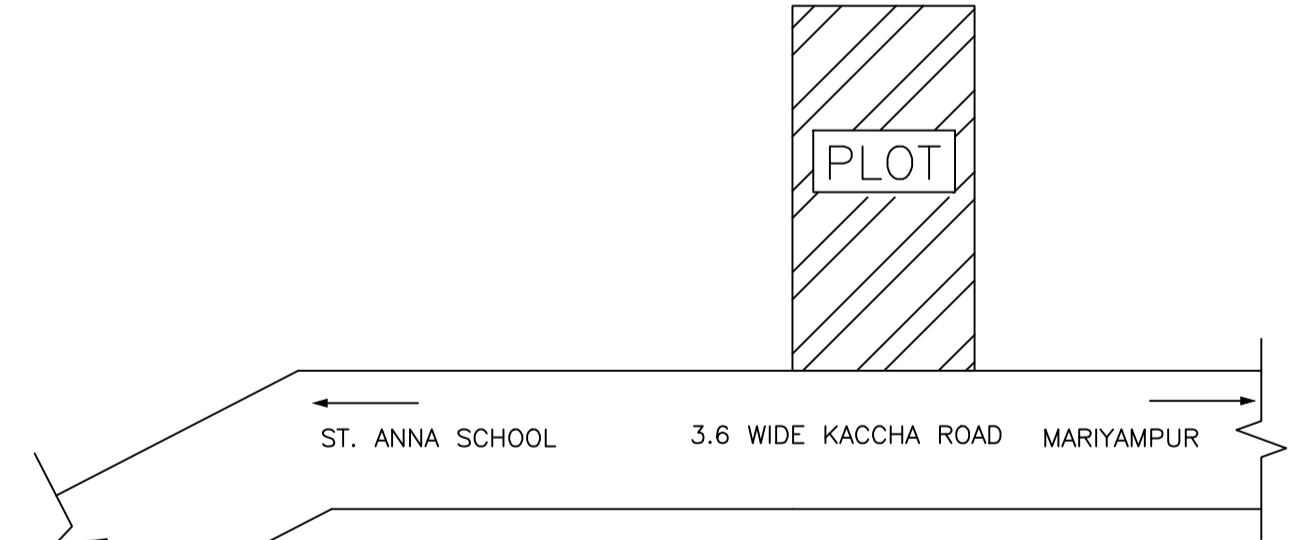
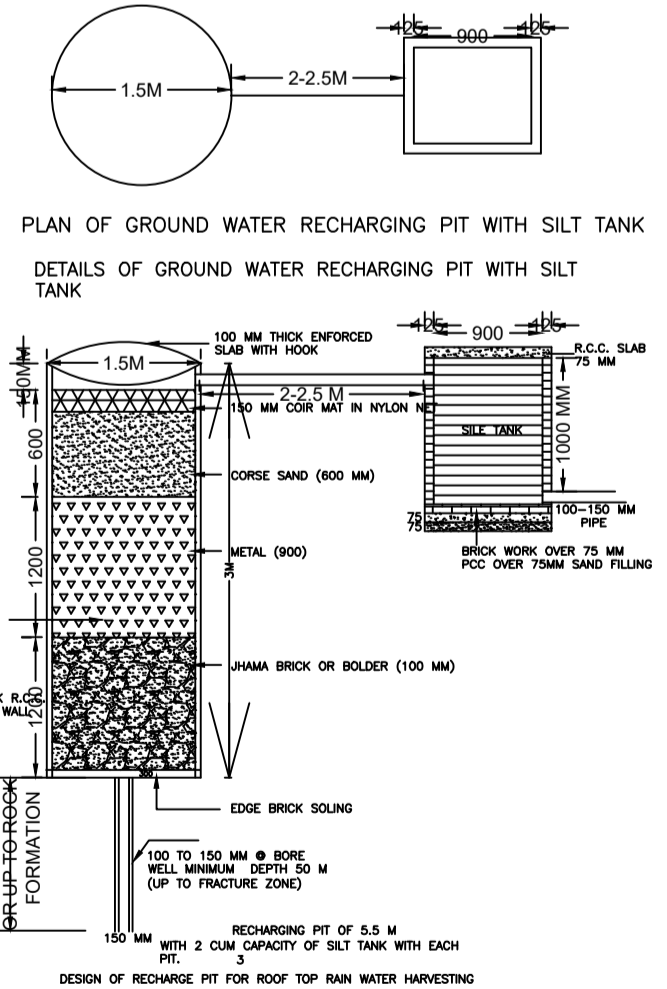

LOCATION PLAN NOT IN SCALE

Building :A (RESIDENTIAL)

Floor Name	Total Built Up Area (Sq.mt.)	Proposed FAR Area (Sq.mt.) Resi.	Total FAR Area (Sq.mt.)	Total Consumed Additional FAR Area (Sq.mt.)	Tnmt (No.)
Ground Floor	136.96	136.96	136.96	136.96	01
First Floor	152.13	152.13	152.13	152.13	00
Terrace Floor	0.00	0.00	0.00	0.00	00
Total:	289.09	289.09	289.09	289.09	01
Total Number of Same Buildings	1				
Total:	289.09	289.09	289.09	289.09	01

SCHEDULE OF DOOR:

BUILDING NAME	NAME	LENGTH	HEIGHT	NOS
A (RESIDENTIAL)	D2	0.76	2.10	07
A (RESIDENTIAL)	D1	0.91	2.10	04
A (RESIDENTIAL)	D	1.07	2.10	12
A (RESIDENTIAL)	D3	1.83	2.10	01

SCHEDULE OF WINDOW/VENTILATION:

BUILDING NAME	NAME	LENGTH	HEIGHT	NOS
A (RESIDENTIAL)	V	0.76	0.61	05
A (RESIDENTIAL)	W2	0.91	1.20	03
A (RESIDENTIAL)	W1	1.22	1.20	15

UnitBUA Table for Building :A (RESIDENTIAL)

FLOOR	Name	UnitBUA Type	UnitBUA Area	Carpet Area	No. of Rooms	No. of Tenement
GROUND FLOOR PLAN	SPLIT A	FLAT	234.91	234.13	11	1
FIRST FLOOR PLAN	SPLIT A	FLAT	0.00	0.00	15	0
Total:	-	-	234.91	234.13	26	1

LTP NAME AND SIGNATURE	STRUCTURAL ENG'S NAME AND SIGNATURE	BUILDER NAME AND SIGNATURE	DIGITAL SIGNATURE
MAHENDRA MEHTA SINPC/DFTMN/0002/2022			

Proposal Basic Information

Proposal File No.	SINPC/BP/0411/W01/2023
Owner Name	LUCIA BILUNG
Khata No	268
Plot No	3132
Village Name	Gotra
Use	Residential
SubUse	Bungalow/ Dwelling / Non Apartment

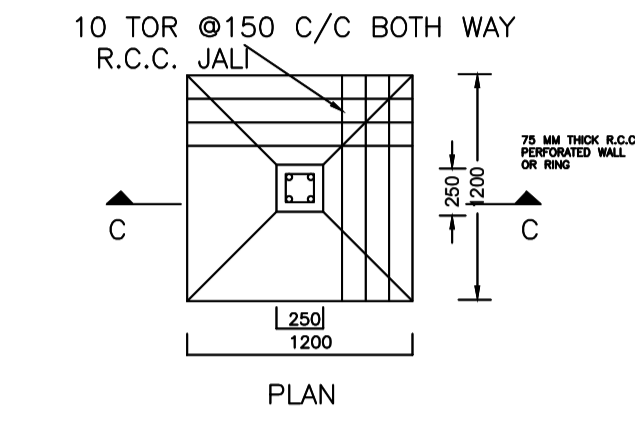

PLAN
DETAIL OF FOUNDATION

SCALE:-
1:5

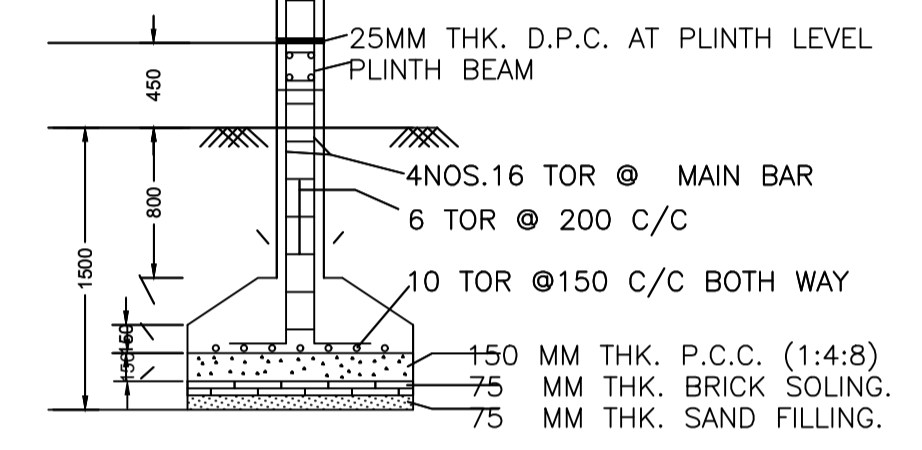

SECTION -CC

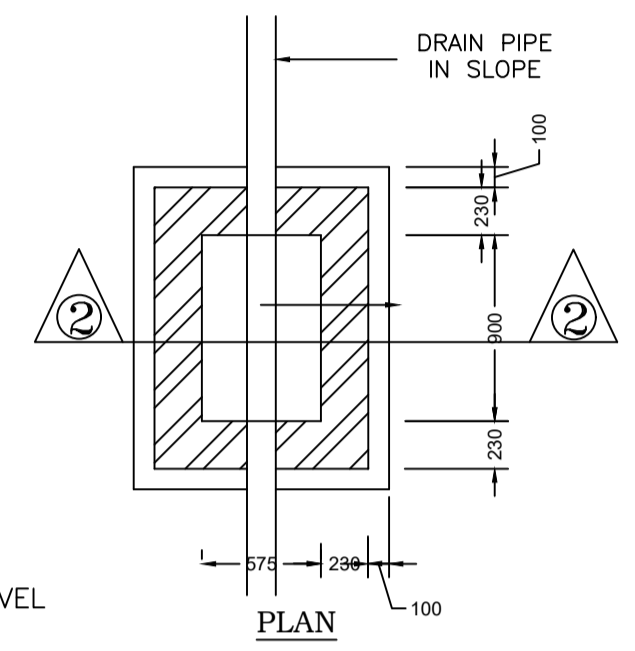

PLAN
I.C. DETAILS

R.C.C.
COVER

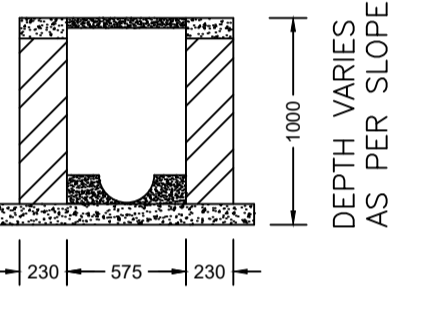

SECTION AT 2-2

LTP NAME AND SIGNATURE	STRUCTURAL ENG'S NAME AND SIGNATURE	BUILDER NAME AND SIGNATURE	DIGITAL SIGNATURE
MAHENDRA MEHTA SINPC/DFTMN/0002/2022			