

# SITE PLAN

### FAR & Tenement Details (Table 4c-1)

Building	No. of Same Bldg	Total Built Up Area (Sq.mt.)	Deductions (Area in Sq.mt.)	Proposed FAR Area (Sq.mt.)	Total FAR Area (Sq.mt.)	Total Consumed Additional FAR Area (Sq.mt.)	Tnmt (No.)
A (RESIDENCE)	1	302.61	20.94	281.67	281.67	281.67	01
Grand Total :	1	302.61	20.94	281.67	281.67	281.67	01

### Proposal Basic Information

Proposal File No.	SINPC/BP/0413/W06/2023
Owner Name	MAKSIMA TOPPO
Khata No	72
Plot No	2607
Village Name	Khijri
Use	Residential
SubUse	Bungalow/ Dwelling / Non Apartment

AREA STATEMENT SIMDEGA NAGAR PANCHAYAT		VERSION NO. : 1.0.66
PROJECT DETAIL		VERSION DATE: 16/10/2020
Region: JHARKHAND URBAN LOCAL BODIES	Plot Use: Residential	
District: SIMDEGA	Plot SubUse: Bungalow/ Dwelling / Non Apartment	
Authority: SIMDEGA NAGAR PANCHAYAT	PlotNearbyReligiousStructure: NA	
Inward No: SINPC/BP/0413/W06/2023	PlotSubPlot No: 2607	
Application Type: General Proposal	North: -	
Project Type: Building Permission	South: -	
Nature of Development: New	East: -	
Location of Development Area: Old Area	West: -	
AREA DETAILS:		
AREA OF PLOT (Minimum)	(A)	SQ.MT. 1092.67
Deduction for NetPlot Area		
Surrender Free of Cost		127.66
Total		127.66
NET AREA OF PLOT(Gross Plot Area - Deduction from Gross Plot area)	(A-Deductions)	965.01
Deduction for Balance Plot Area(from Gross Plot Area)		
Surrender Free of Cost		127.66
Common Plot		52.13
Total		179.79
BALANCE AREA OF PLOT(Net Plot Area - Recreational/Amenity space)	(A-Deductions)	912.88
PLOT AREA FOR COVERAGE(Net Plot Area)	(A-Deductions)	965.01
Plot Area for FAR (Net Plot Area + RoadWidening Area)	(A-Deductions)	1092.67
COVERAGE CHECK		
Permissible Coverage area ( 60.00 % )		579.01
Proposed Coverage Area ( 16.33 % )		157.59
Total Prop. Coverage Area ( 16.33 % )		157.59
Balance coverage area ( 43.67 % )		421.42
FAR CHECK		
Perm. FAR Area ( 1.800 )		1966.81
Total Perm. FAR area		1966.81
Residential FAR		281.67
Proposed FAR Area		281.67
Total Proposed FAR Area		281.67
Consumed FAR (Factor)		0.26
Balance FAR Area		1685.14
BUILT UP AREA CHECK		
Total Proposed BuiltUp Area		302.61
ARCHITECT (Regd)	MAHENDRA MEHTA	
ENGINEER (Regd)		
SUPERVISOR (Regd)		
OWNER (Regd)	MAKSIMA TOPPO	
DEVELOPMENT AUTHORITY		LOCAL BODY

COLOR INDEX	
PLOT BOUNDARY	Black
ABUTTING ROAD	Green
PROPOSED CONSTRUCTION	Red
COMMON PLOT	Yellow
ROAD WIDENING AREA	Orange
EXISTING (To be retained)	Blue
EXISTING (To be demolished)	Light Blue

### Buildingwise Floor FAR Details

Floor Name	Building Name A (RESIDENCE)		Total	
	Proposed Built Up Area (Sq.mt.)	Proposed FAR Area (Sq.mt.)	Total Proposed Built Up Area (Sq.mt.)	Total FAR Area (Sq.mt.)
Ground Floor	157.59	136.65	157.59	136.65
First Floor	145.02	145.02	145.02	145.02
Terrace Floor	0.00	0.00	0.00	0.00
Total :	302.61	281.67	302.61	281.67

### Building USE/SUBUSE Details

Building Name	Building Use	Building SubUse	Building Structure
A (RESIDENCE)	Residential	Bungalow/ Dwelling / Non Apartment	Non-Highrise

LTP NAME AND SIGNATURE	STRUCTURAL ENG'S NAME AND SIGNATURE	BUILDER NAME AND SIGNATURE	DIGITAL SIGNATURE
MAHENDRA MEHTA SINPC/DFTMN/0002/2022			

Proposal Basic Information	
Proposal File No.	SINPC/BP/0413/W06/2023
Owner Name	MAKSIMA TOPPO
Khata No	72
Plot No	2607
Village Name	Khijri
Use	Residential
SubUse	Bungalow/ Dwelling / Non Apartment

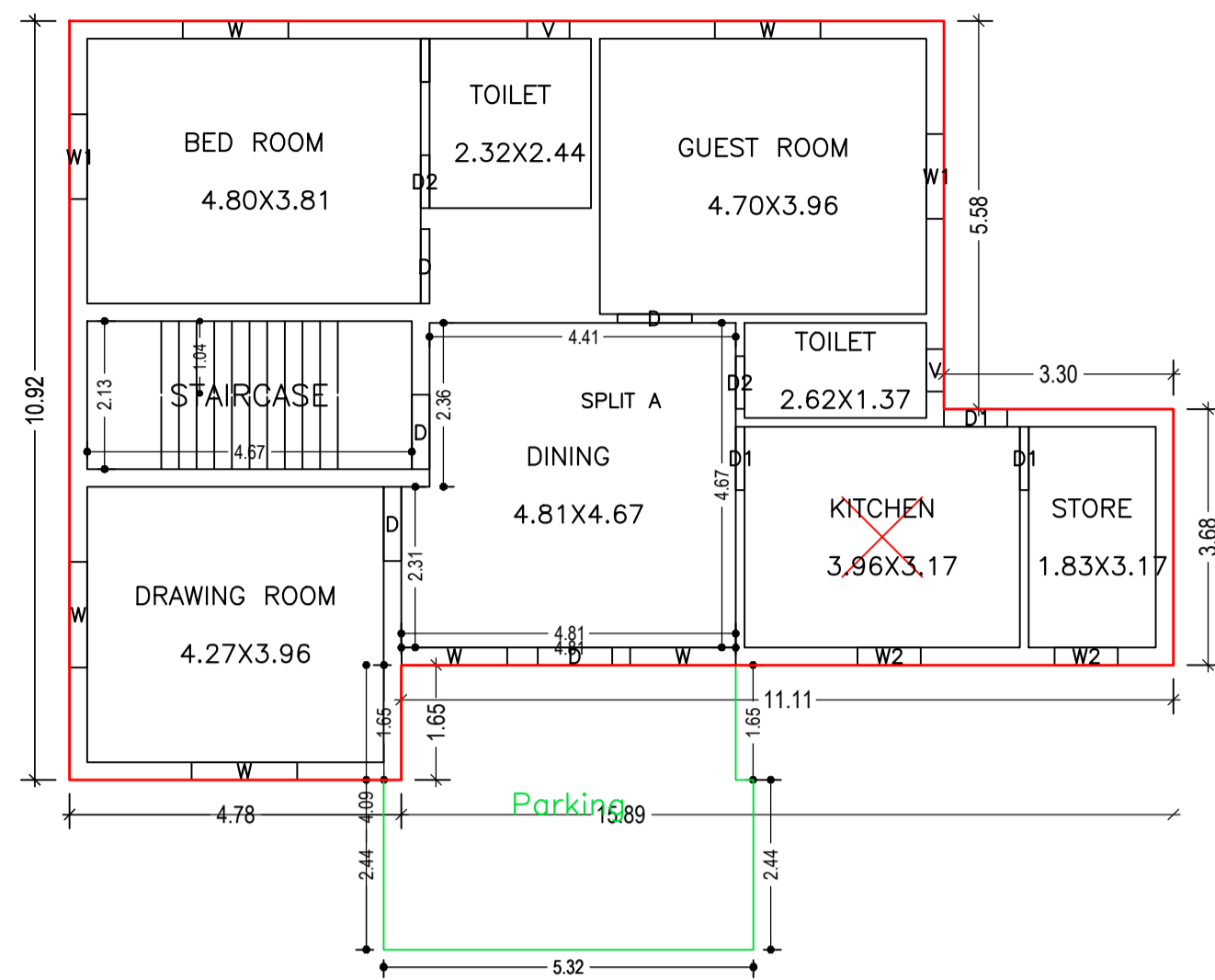

GROUND FLOOR PLAN (Proposed) (SCALE 1:100)

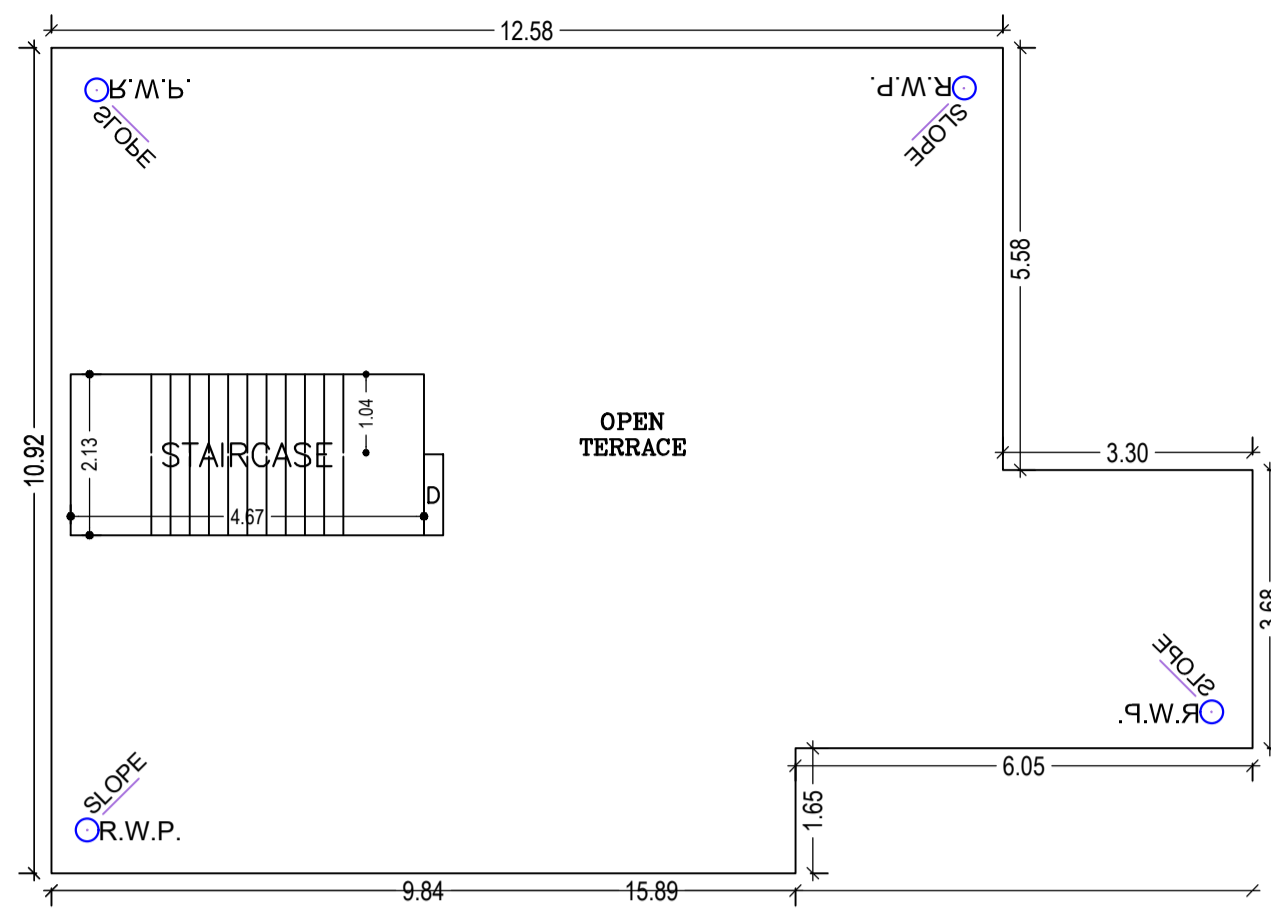

TERRACE FLOOR PLAN (SCALE 1:100)

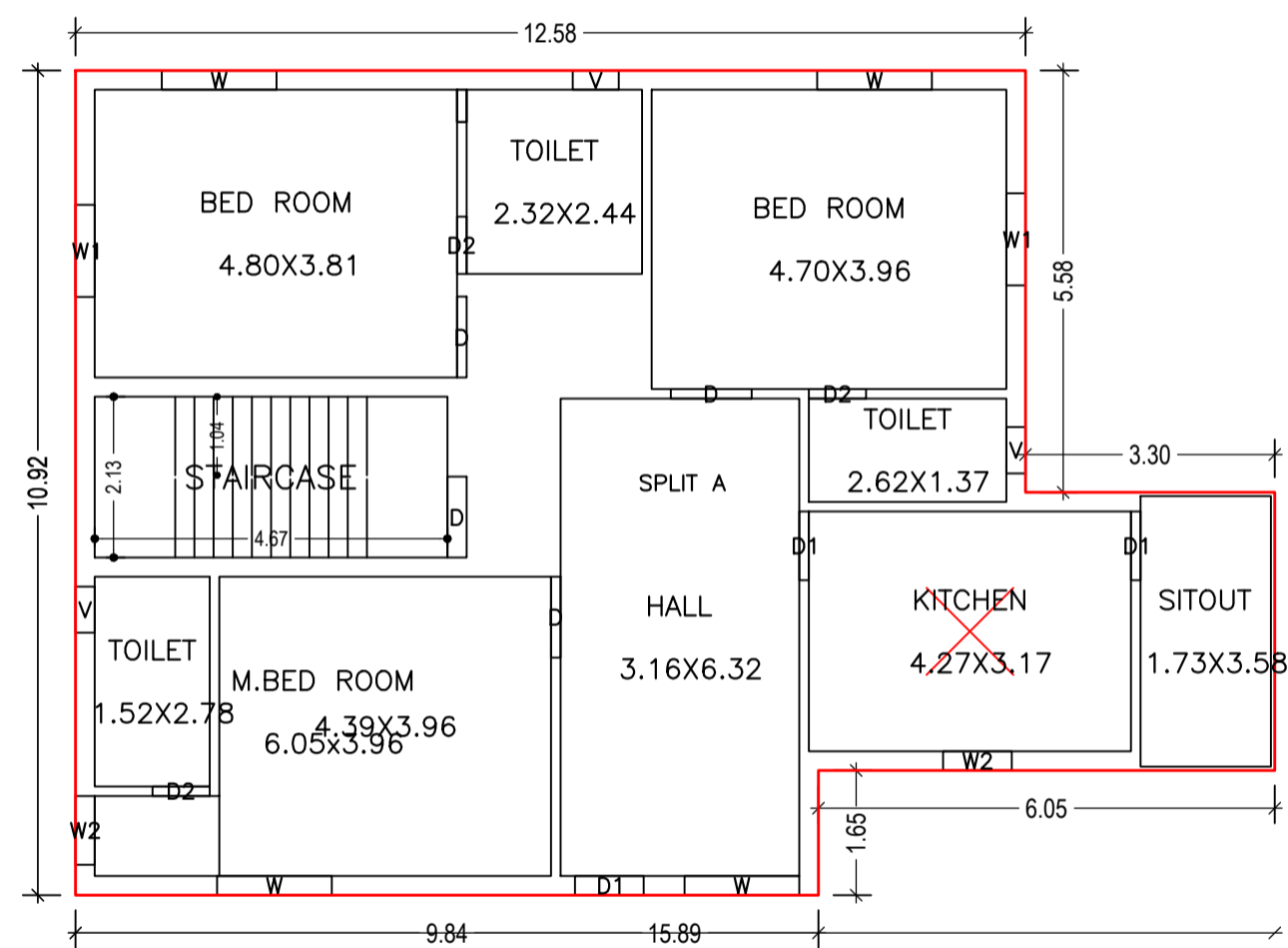

FIRST FLOOR PLAN (Proposed) (SCALE 1:100)

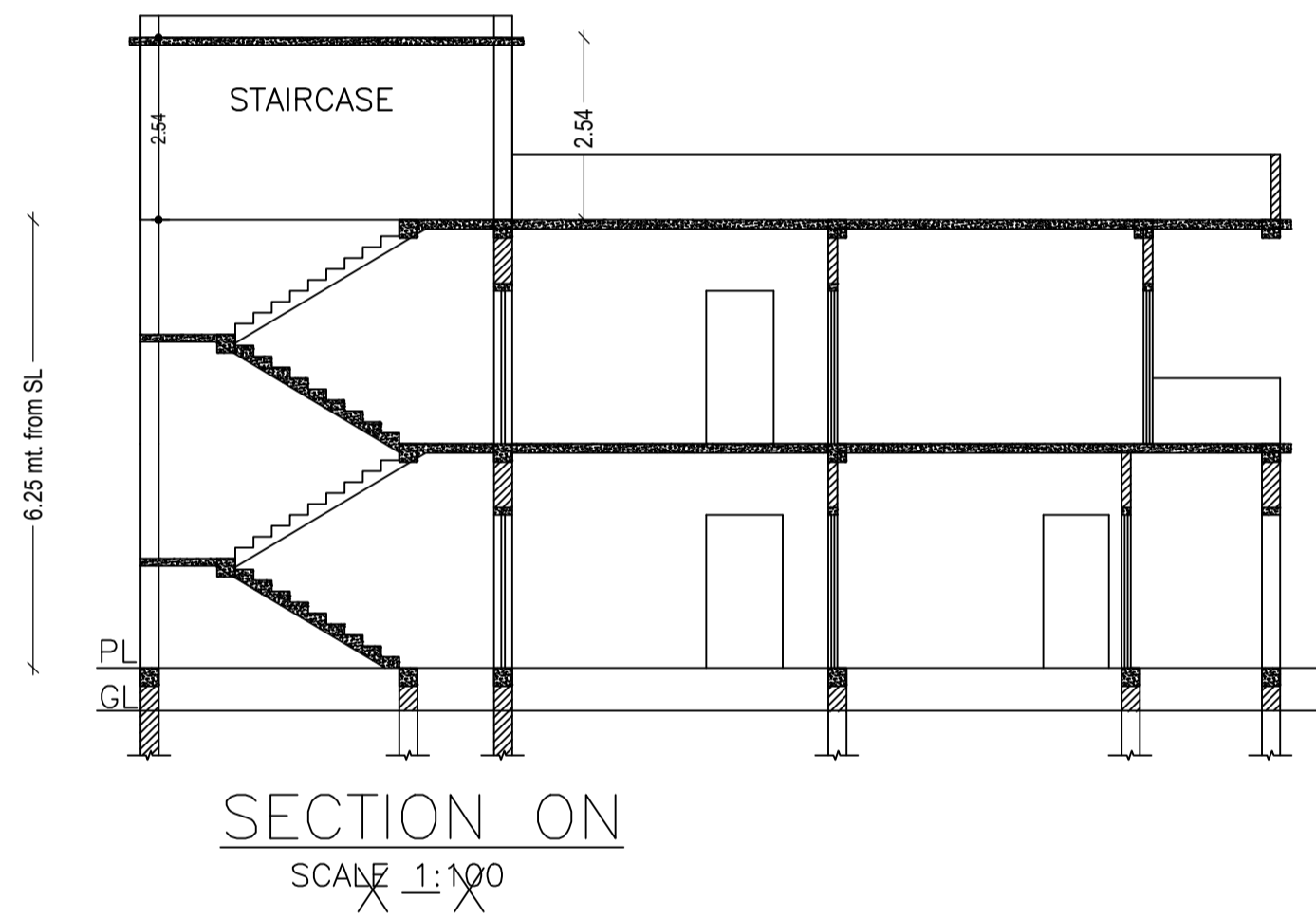

SECTION ON (SCALE 1:100)

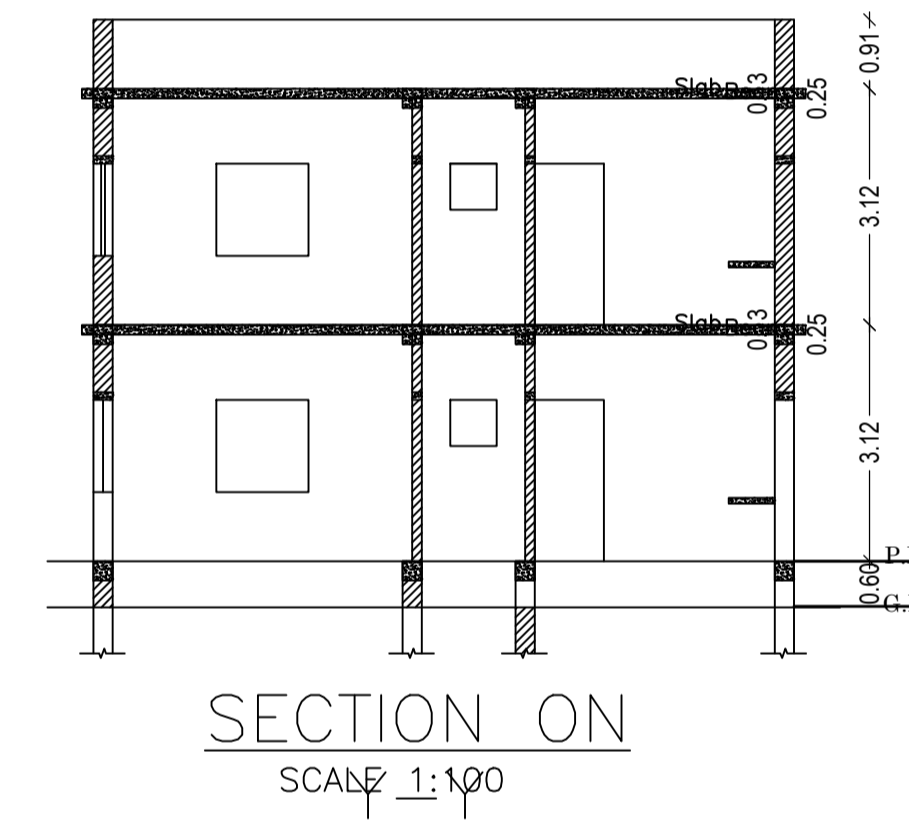

SECTION ON (SCALE 1:100)

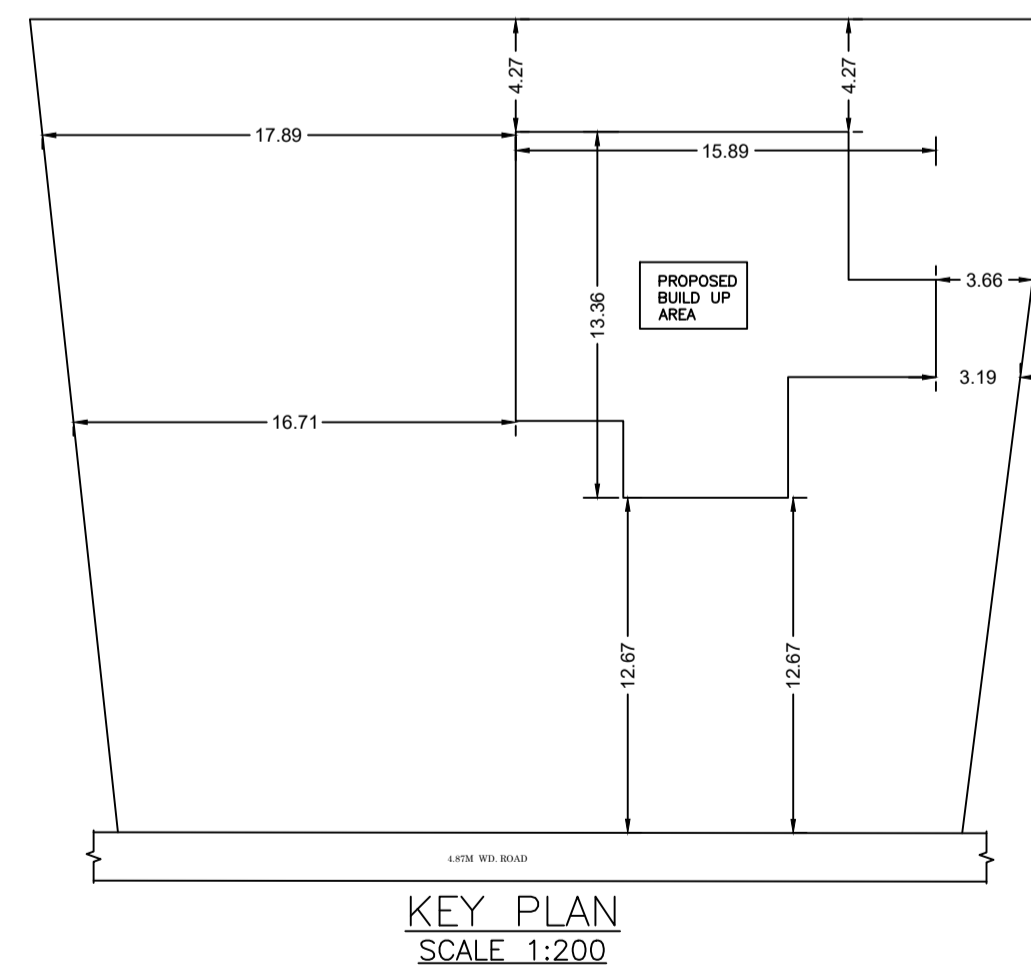

KEY PLAN (SCALE 1:200)

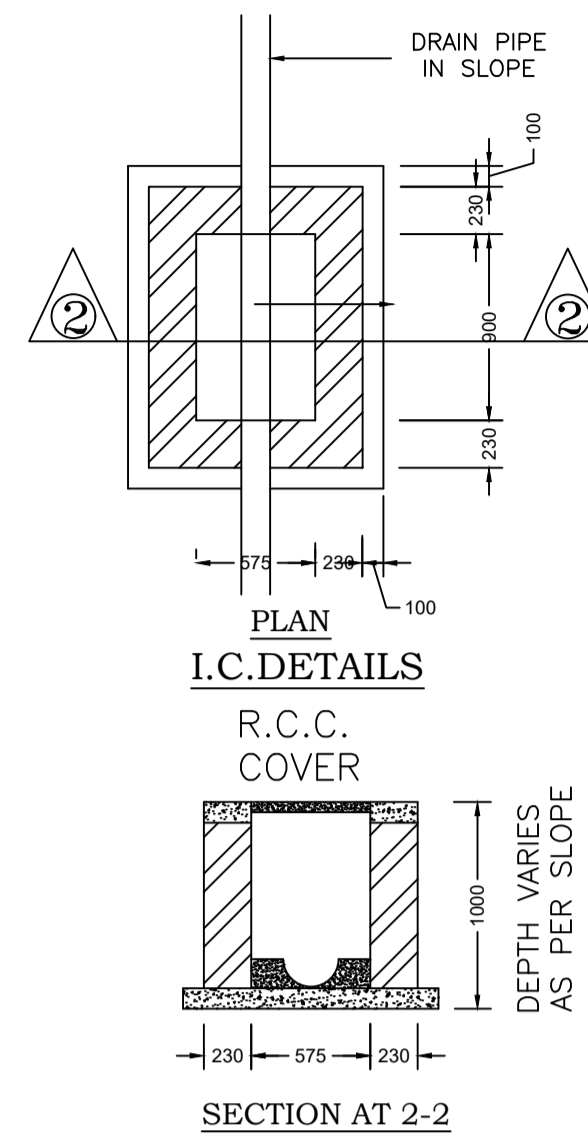

SECTION AT 2-2

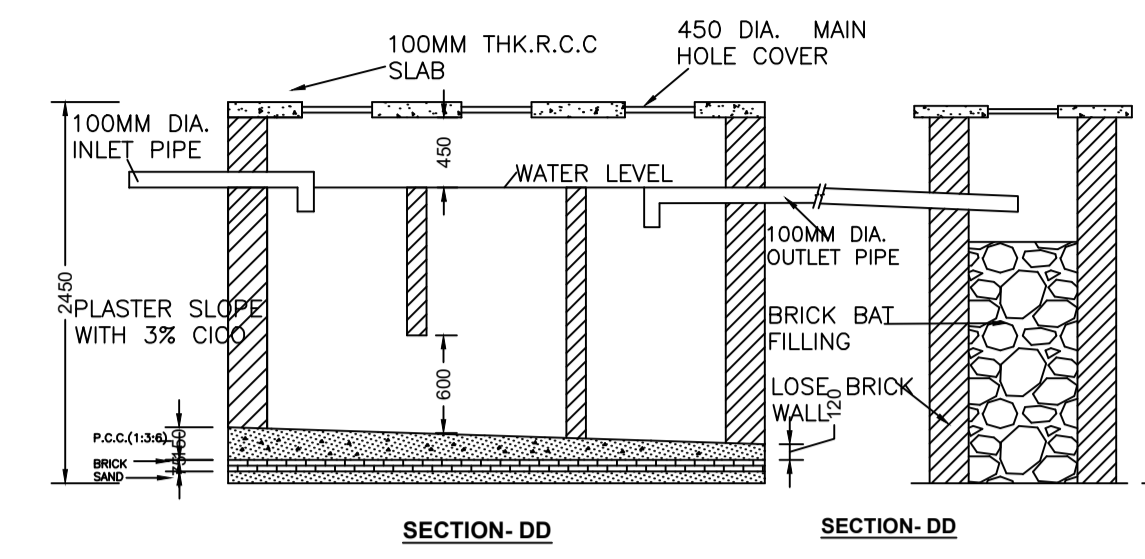

DETAIL OF SEPTIC TANK & SOAKPIT.

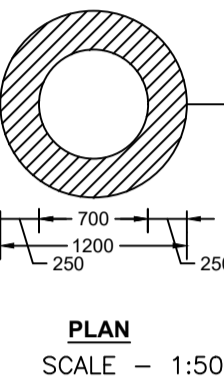

PLAN (SCALE 1:50)

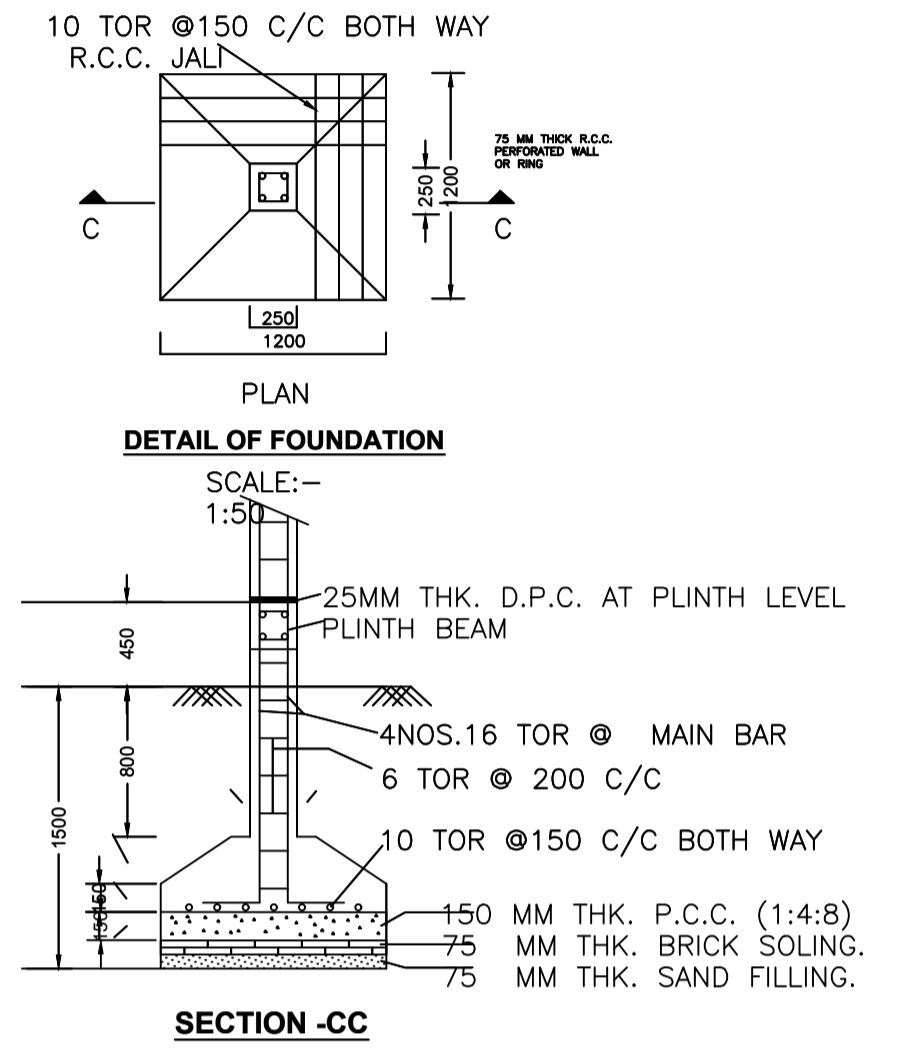

DETAIL OF FOUNDATION (SCALE 1:50)

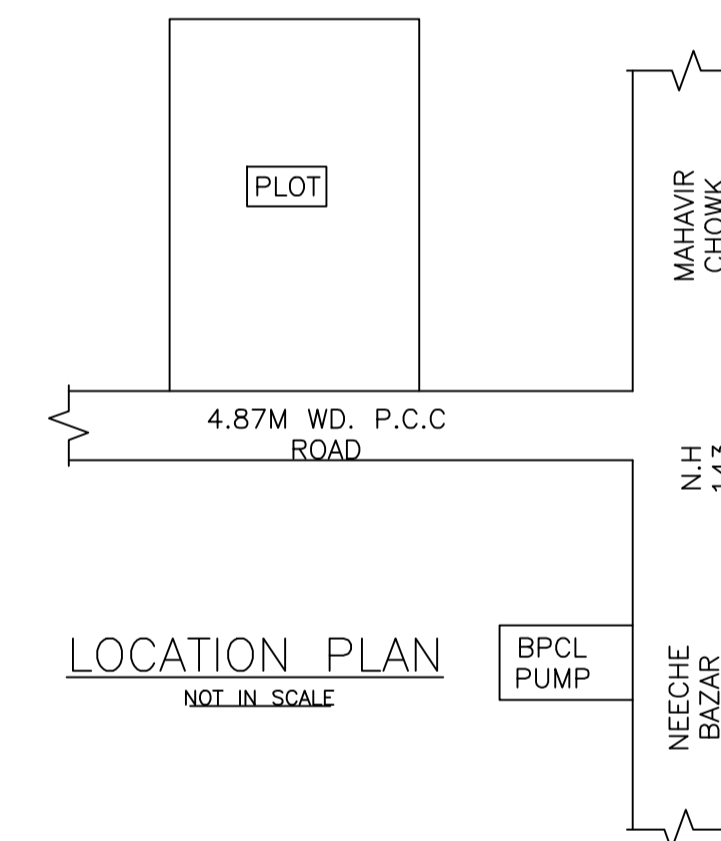

LOCATION PLAN (NOT IN SCALE)

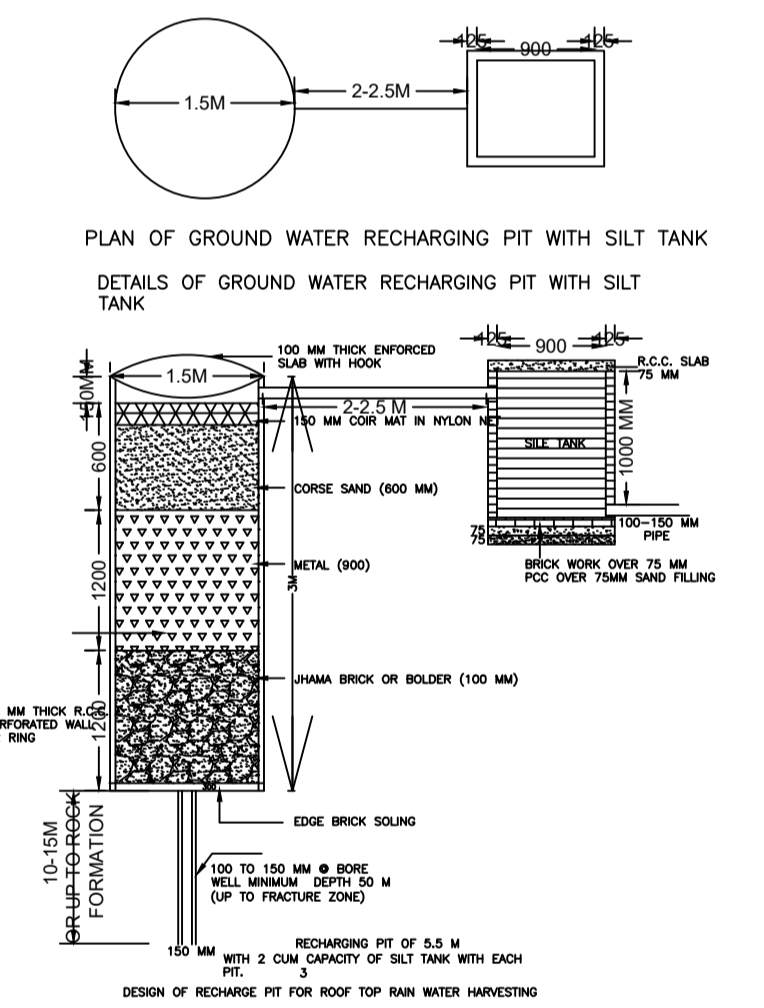

DESIGN OF RECHARGE PIT FOR ROOF TOP RAIN WATER HARVESTING

Building :A (RESIDENCE)

Floor Name	Total Built Up Area (Sq.mt.)	Deductions (Area in Sq.mt.)	Proposed FAR Area (Sq.mt.)	Total FAR Area (Sq.mt.)	Total Consumed Additional FAR Area (Sq.mt.)	Trmt (No.)
Ground Floor	157.59	20.94	136.65	136.65	136.65	01
First Floor	145.02	0.00	145.02	145.02	145.02	00
Terrace Floor	0.00	0.00	0.00	0.00	0.00	00
Total :	302.61	20.94	281.67	281.67	281.67	01
Total Number of Same Buildings	1					
Total :	302.61	20.94	281.67	281.67	281.67	01

SCHEDULE OF DOOR:

BUILDING NAME	NAME	LENGTH	HEIGHT	NOS
A (RESIDENCE)	D2	0.76	2.10	05
A (RESIDENCE)	D1	0.91	2.10	06
A (RESIDENCE)	D	1.07	2.10	08

SCHEDULE OF WINDOW/VENTILATION:

BUILDING NAME	NAME	LENGTH	HEIGHT	NOS
A (RESIDENCE)	V	0.61	1.20	05
A (RESIDENCE)	W2	0.91	1.20	04
A (RESIDENCE)	W1	1.22	1.20	04
A (RESIDENCE)	W	1.52	1.20	10

UnitBUA Table for Building :A (RESIDENCE)

FLOOR	Name	UnitBUA Type	UnitBUA Area	Carpet Area	No. of Rooms	No. of Tenement
GROUND FLOOR PLAN	SPLIT A	FLAT	230.31	230.18	8	1
FIRST FLOOR PLAN	SPLIT A	FLAT	0.00	0.00	9	0
Total:	-	-	230.31	230.18	17	1

LTP NAME AND SIGNATURE	STRUCTURAL ENG'S NAME AND SIGNATURE	BUILDER NAME AND SIGNATURE	DIGITAL SIGNATURE
MAHENDRA MEHTA SINPC/DFTMN/0002/2022			

Proposal Basic Information	
Proposal File No.	SINPC/BP/0413/W06/2023
Owner Name	MAKSIMA TOPPO
Khata No	72
Plot No	2607
Village Name	Khijri
Use	Residential
SubUse	Bungalow/ Dwelling / Non Apartment

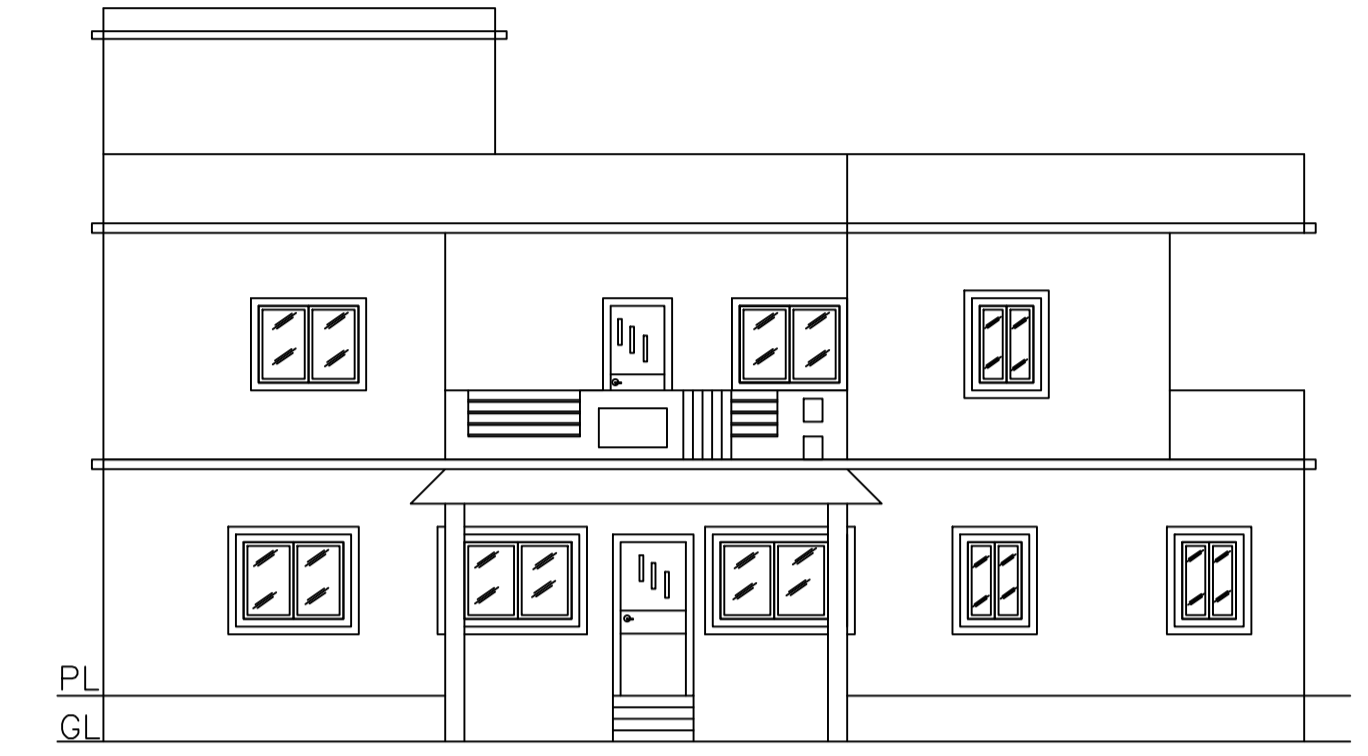

FRONT ELEVATION  
SCALE 1:100

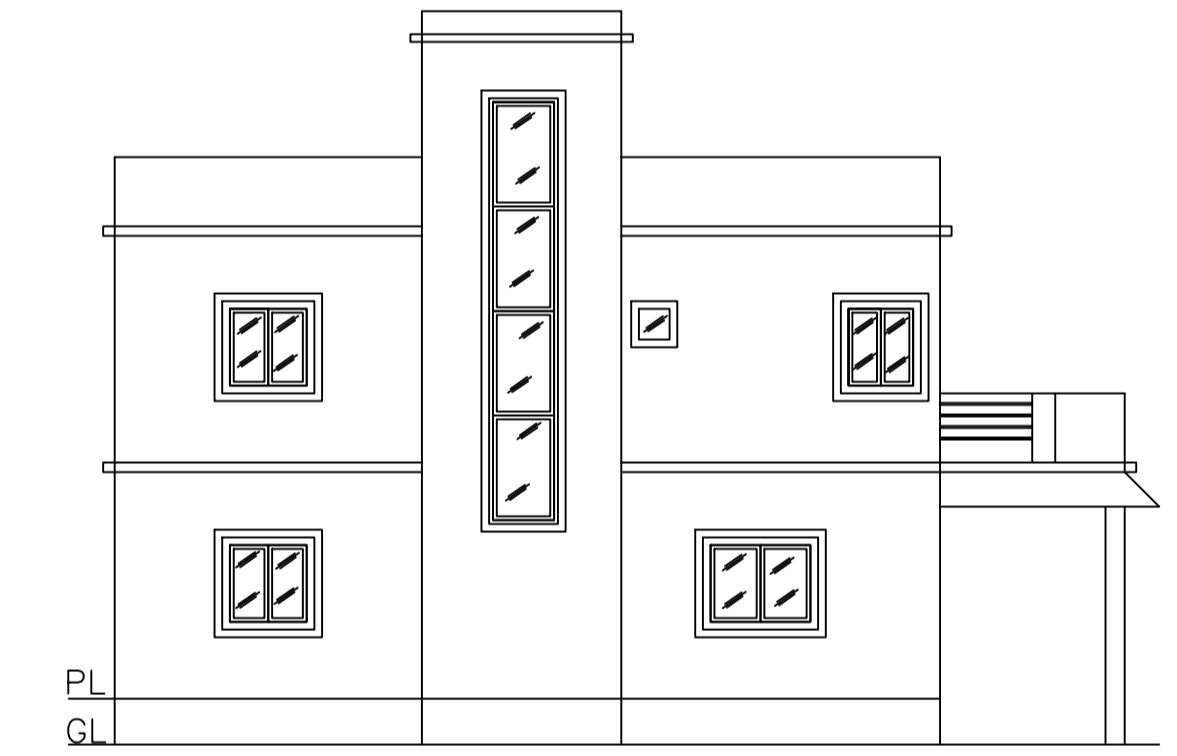

LEFT SIDE ELEVATION  
SCALE 1:100

LTP NAME AND SIGNATURE	STRUCTURAL ENG'S NAME AND SIGNATURE	BUILDER NAME AND SIGNATURE	DIGITAL SIGNATURE
MAHENDRA MEHTA SINPC/DFTMN/0002/2022			