

SITE PLAN

FAR & Tenement Details (Table 4c-1)

Building	No. of Same Bldg	Total Built Up Area (Sq.mt.)	Proposed FAR Area (Sq.mt.) Resi.	Total FAR Area (Sq.mt.)	Total Consumed Additional FAR Area (Sq.mt.)	Tnmt (No.)
A (RESIDENCE)	1	354.96	354.96	354.96	354.96	01
Grand Total	1	354.96	354.96	354.96	354.96	01

Proposal Basic Information

Proposal File No.	SINPC/BP/0418/W16/2023
Owner Name	EDWIN ENJRAS BECK
Khata No	93
Plot No	2081
Village Name	Simdega
Use	Residential
SubUse	Bungalow/ Dwelling / Non Apartment

AREA STATEMENT SIMDEGA NAGAR PANCHAYAT		VERSION NO: 1.0.66
PROJECT DETAIL:		VERSION DATE: 16/10/2020
Region: JHARKHAND URBAN LOCAL BODIES	Plot Use: Residential	
District: SIMDEGA	Plot SubUse: Bungalow/ Dwelling / Non Apartment	
Authority: SIMDEGA NAGAR PANCHAYAT	PlotNearbyReligiousStructure: NA	
Inward No: SINPC/BP/0418/W16/2023	PlotSubPlot No: 2081	
Application Type: General Proposal	North: -	
Project Type: Building Permission	South: -	
Nature of Development: New	East: -	
Location of Development Area: Old Area	West: -	
AREA DETAILS:		
AREA OF PLOT (Minimum)	(A)	SQ.MT. 684.79
Deduction for NetPlot Area		
Surrender Free of Cost		2.61
Total		2.61
NET AREA OF PLOT(Gross Plot Area - Deduction from Gross Plot area)		
(A-Deductions)		682.17
Deduction for Balance Plot Area(from Gross Plot Area)		
Surrender Free of Cost		2.61
Common Plot		37.95
Total		40.57
BALANCE AREA OF PLOT(Net Plot Area - Recreational/Amenity space)		
(A-Deductions)		644.22
PLOT AREA FOR COVERAGE(Net Plot Area)		
(A-Deductions)		682.17
Plot Area for FAR (Net Plot Area + Road Widening Area)		
(A-Deductions)		684.79
COVERAGE CHECK		
Permissible Coverage area (60.00 %)		409.30
Proposed Coverage Area (17.34 %)		118.32
Total Prop. Coverage Area (17.34 %)		118.32
Balance coverage area (42.65 %)		290.98
FAR CHECK		
Perm. FAR Area (1.800)		1232.62
Total Perm. FAR area		1232.62
Residential FAR		354.97
Proposed FAR Area		354.97
Total Proposed FAR Area		354.97
Consumed FAR (Factor)		0.52
Balance FAR Area		877.65
BUILT UP AREA CHECK		
Total Proposed BuiltUp Area		354.96
ARCHITECT (Regd)	MAHENDRA MEHTA	
ENGINEER (Regd)		
SUPERVISOR (Regd)		
OWNER (Regd)	EDWIN ENJRAS BECK	
DEVELOPMENT AUTHORITY		LOCAL BODY

COLOR INDEX	
PLOT BOUNDARY	Black
ABUTTING ROAD	Green
PROPOSED CONSTRUCTION	Red
COMMON PLOT	Yellow
ROAD WIDENING AREA	Orange
EXISTING (To be retained)	Blue
EXISTING (To be demolished)	Light Blue

Buildingwise Floor FAR Details

Floor Name	Building Name A (RESIDENCE)		Total	
	Proposed Built Up Area (Sq.mt.)	Proposed FAR Area (Sq.mt.)	Total Proposed Built Up Area (Sq.mt.)	Total FAR Area (Sq.mt.)
Ground Floor	118.32	118.32	118.32	118.32
First Floor	118.32	118.32	118.32	118.32
Second Floor	118.32	118.32	118.32	118.32
Terrace Floor	0.00	0.00	0.00	0.00
Total	354.96	354.96	354.96	354.96

Building USE/SUBUSE Details

Building Name	Building Use	Building SubUse	Building Structure
A (RESIDENCE)	Residential	Bungalow/ Dwelling / Non Apartment	Non-Highrise

LTP NAME AND SIGNATURE	STRUCTURAL ENG'S NAME AND SIGNATURE	BUILDER NAME AND SIGNATURE	DIGITAL SIGNATURE
MAHENDRA MEHTA SINPC/DFTMN/0002/2022			

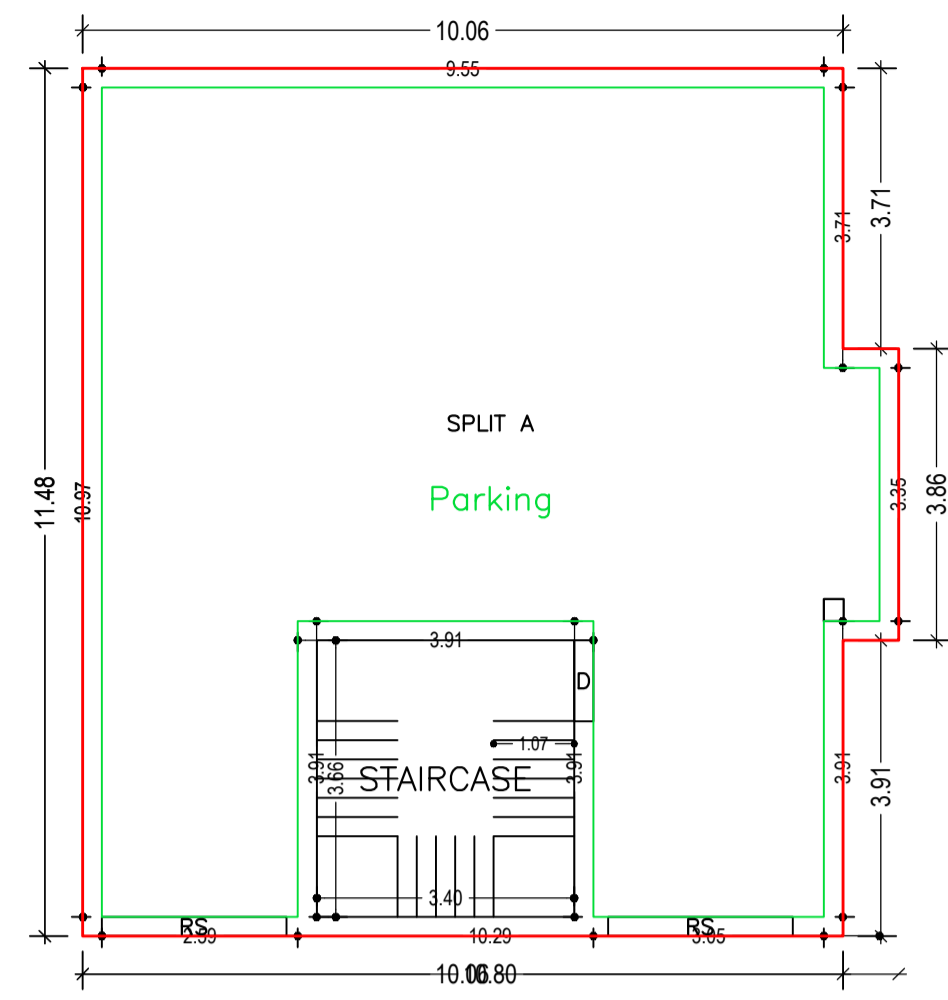

GROUND FLOOR PLAN (Proposed) (SCALE 1:100)

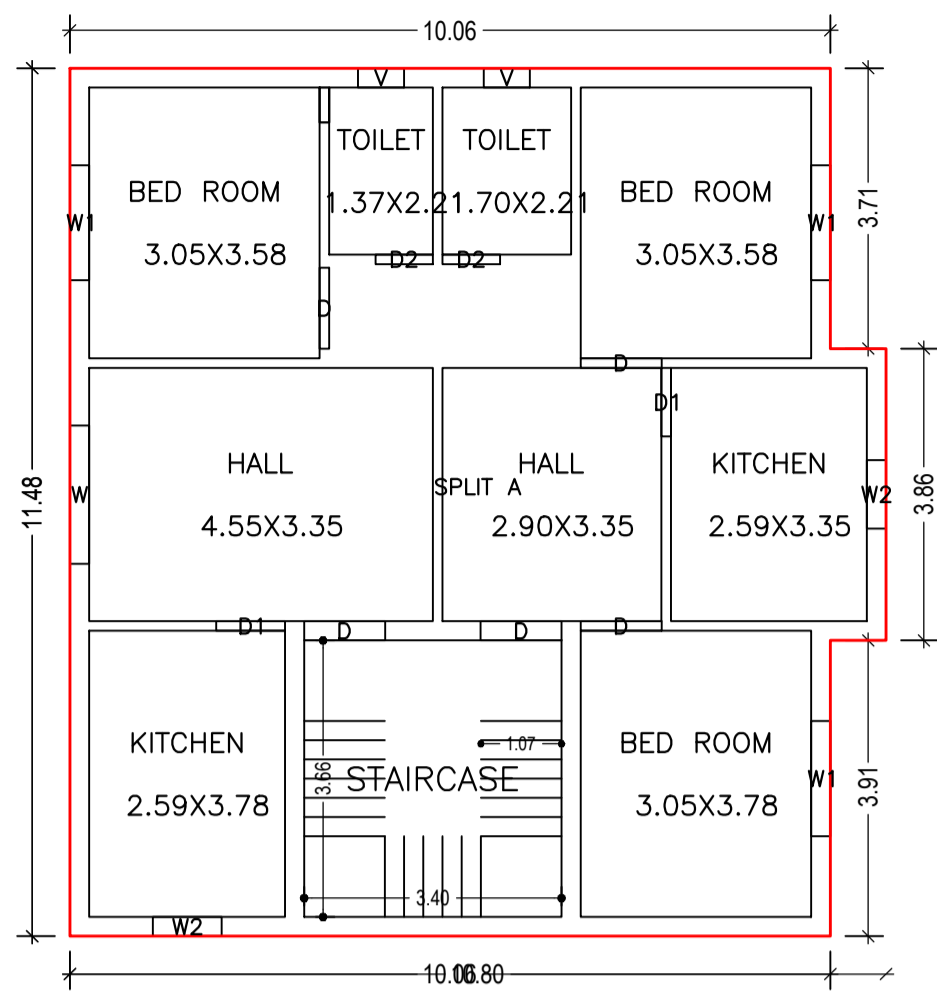

SECOND FLOOR PLAN (Proposed) (SCALE 1:100)

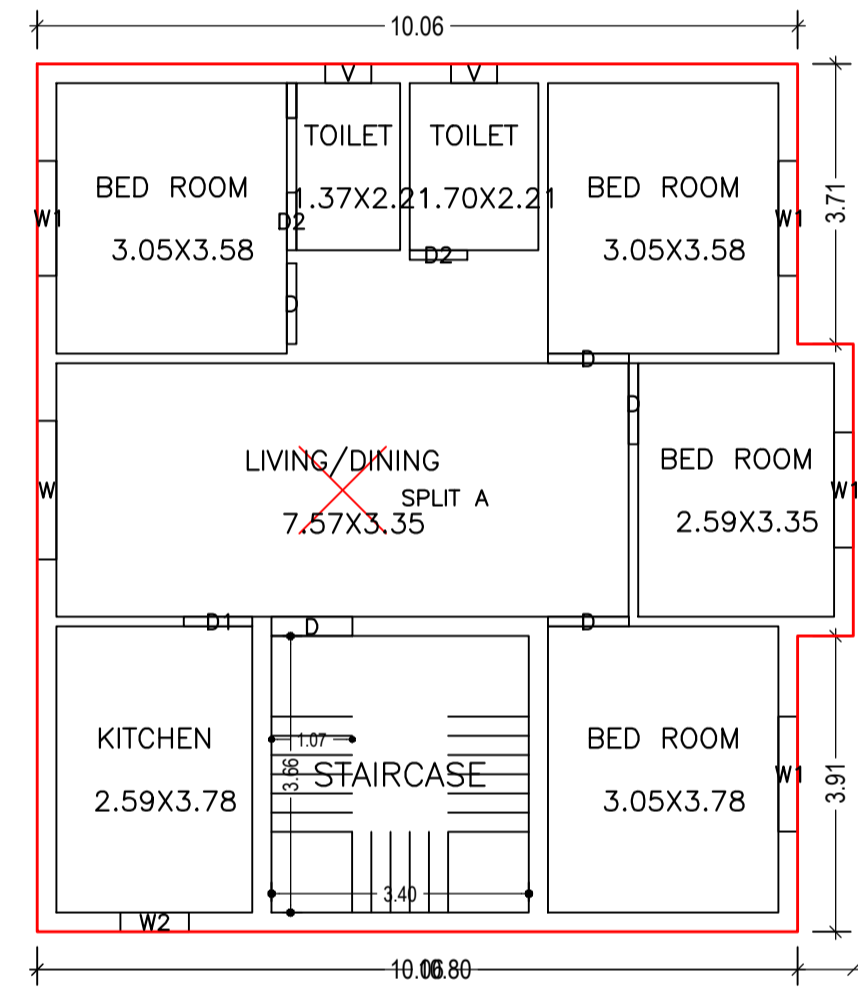

FIRST FLOOR PLAN (Proposed) (SCALE 1:100)

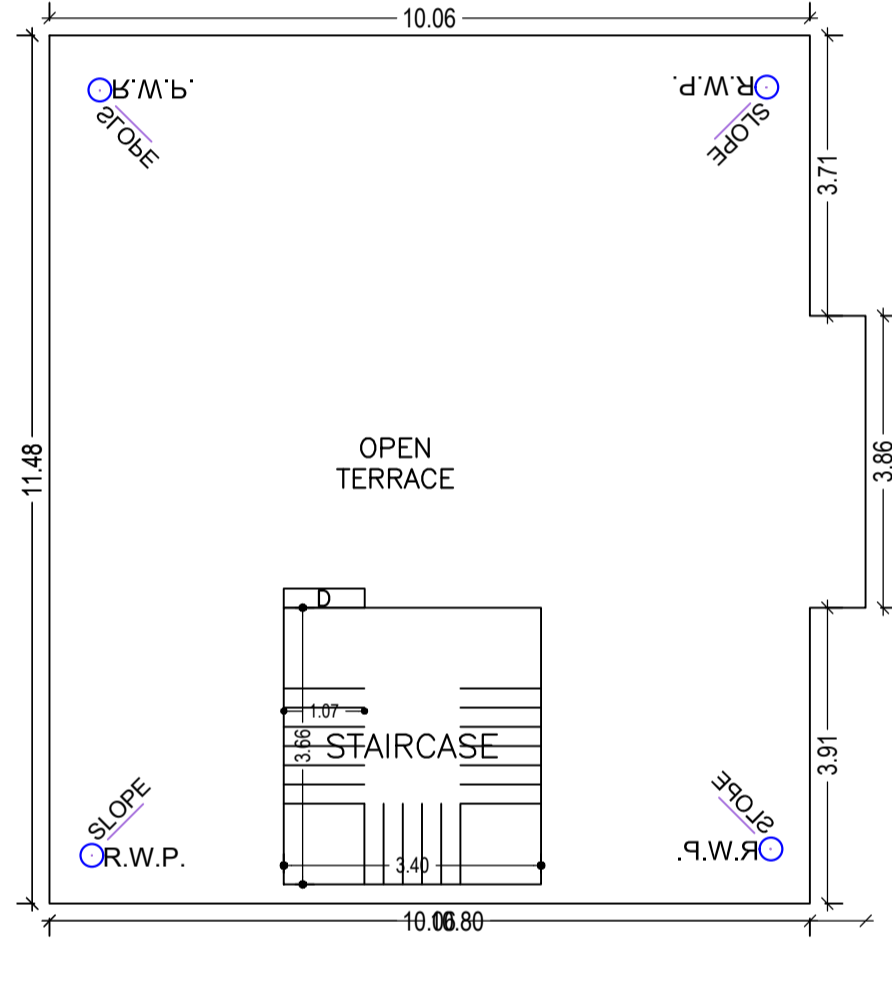

TERRACE FLOOR PLAN (SCALE 1:100)

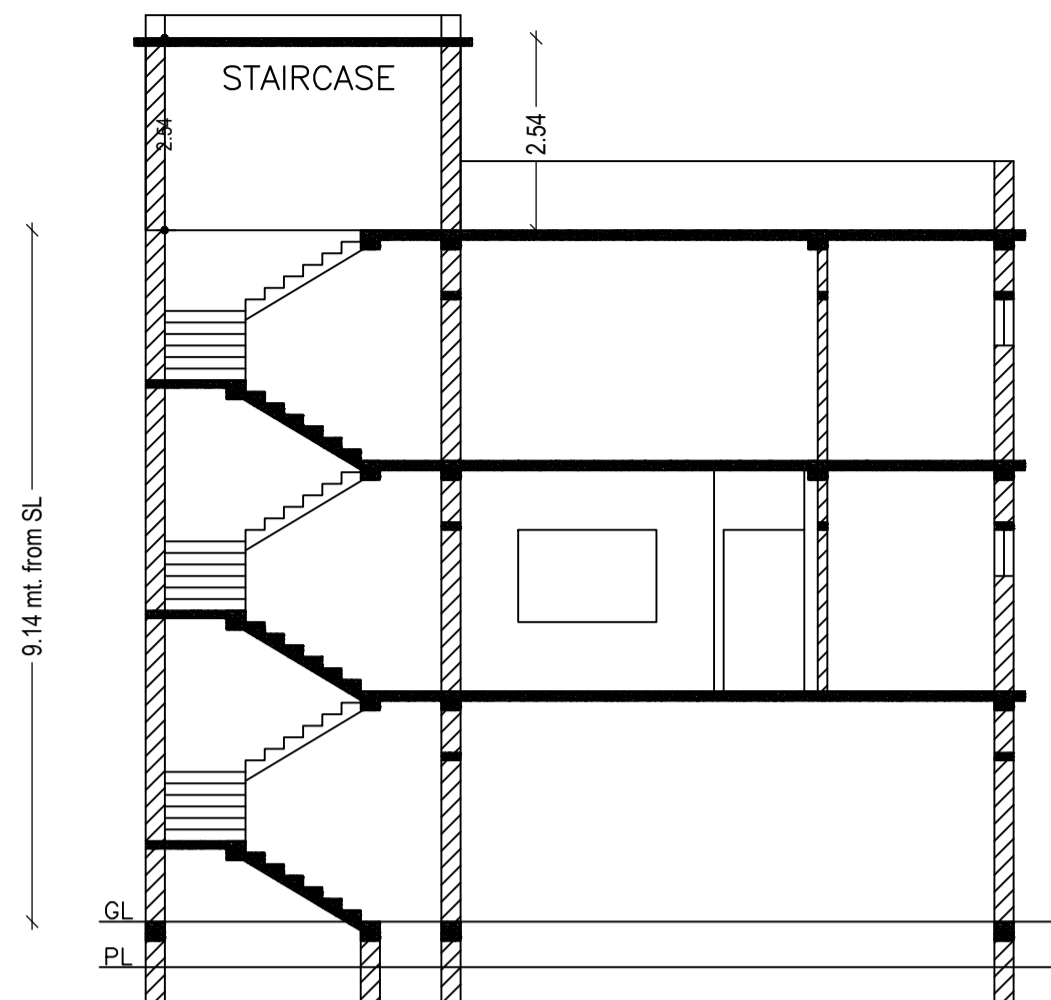

SECTION ON SCALE 1:100

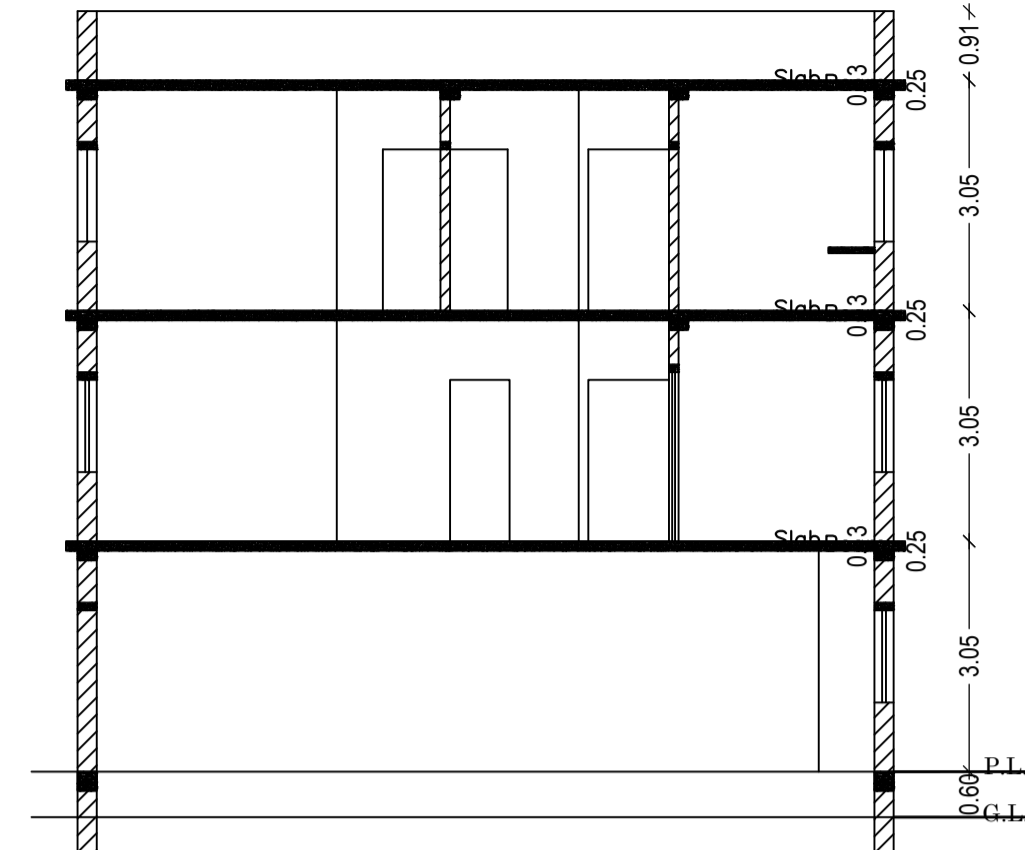

SECTION ON SCALE 1:100

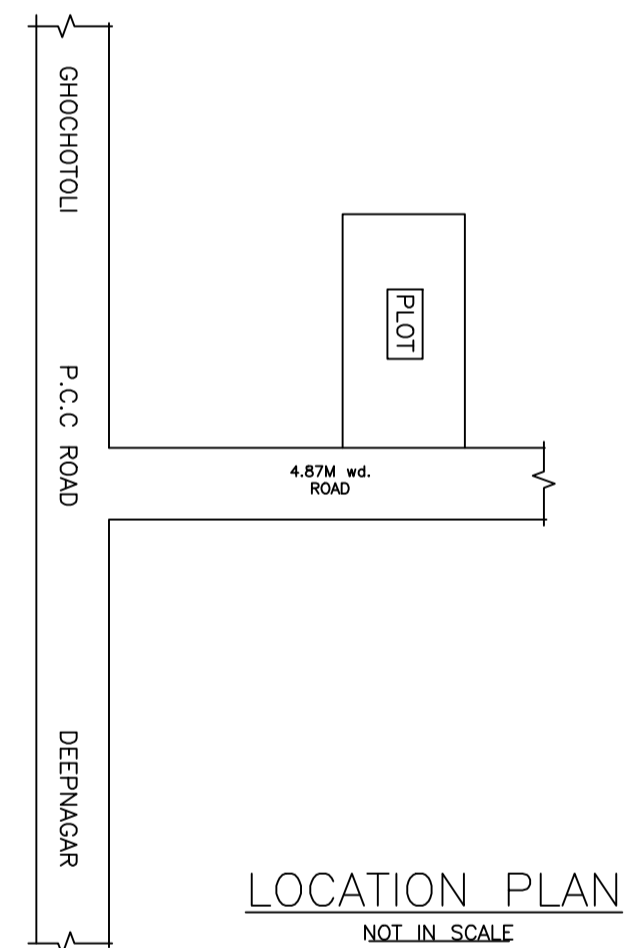

LOCATION PLAN NOT IN SCALE

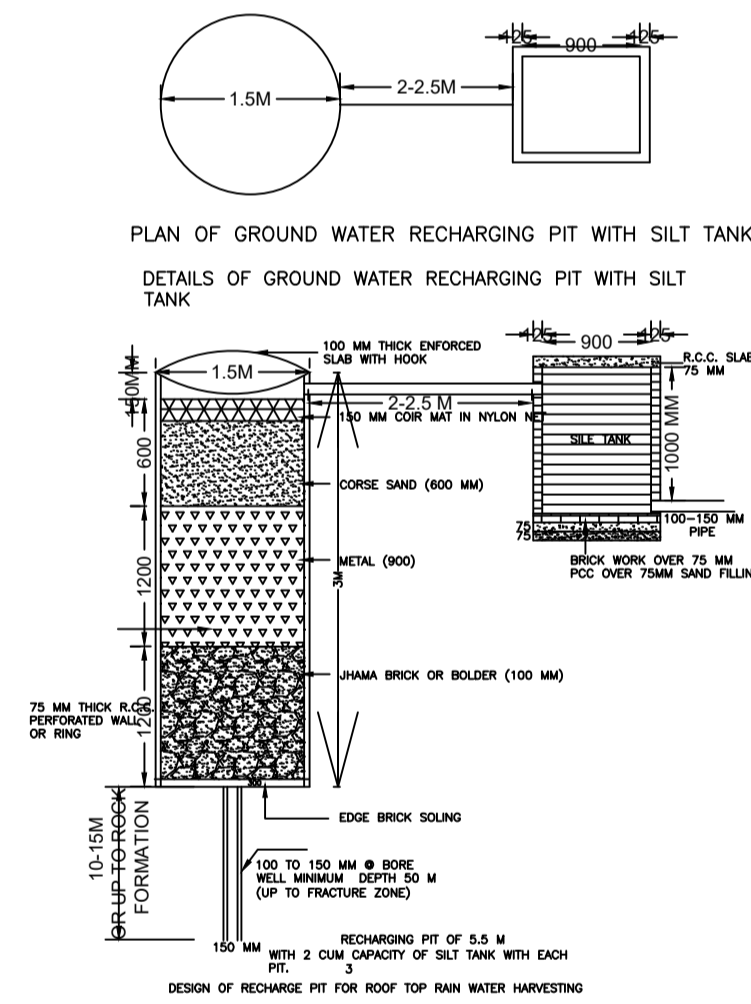

DESIGN OF RECHARGE PIT FOR ROOF TOP RAIN WATER HARVESTING

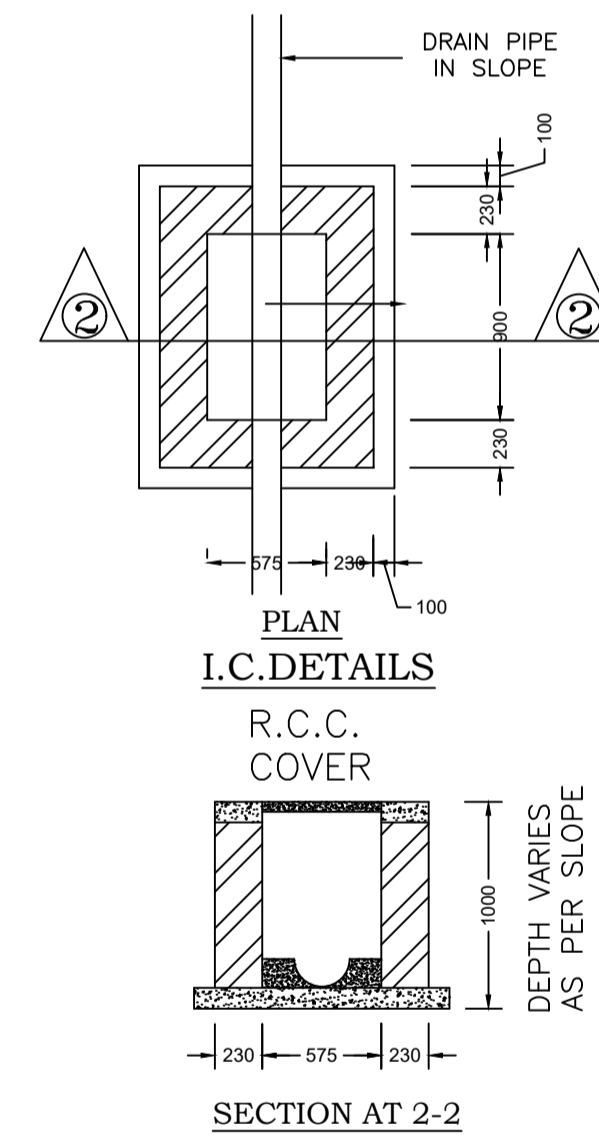

I.C. DETAILS R.C.C. COVER SECTION AT 2-2

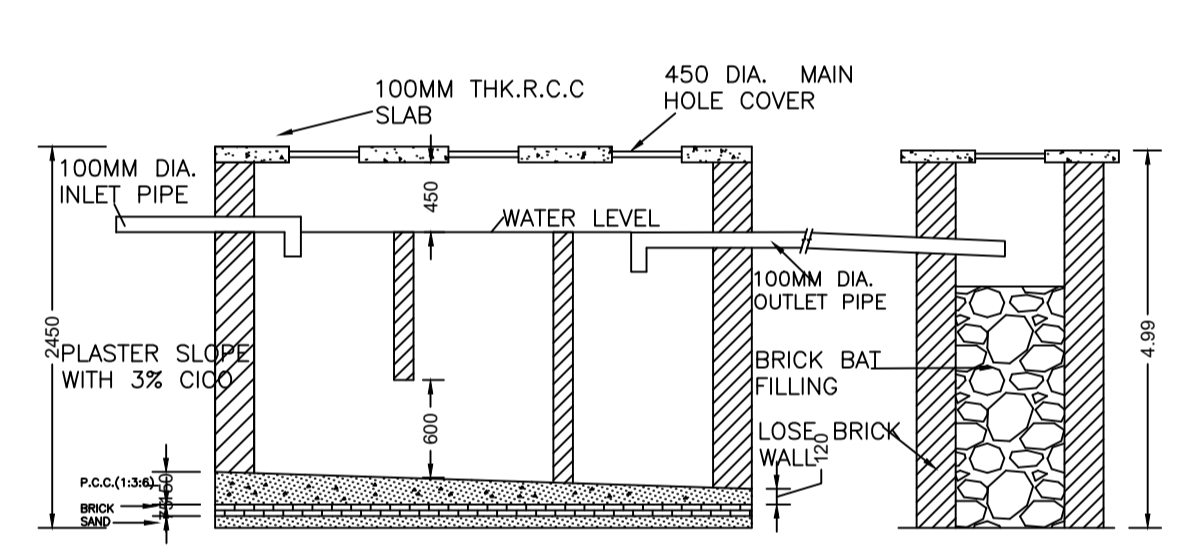

SECTION-DD

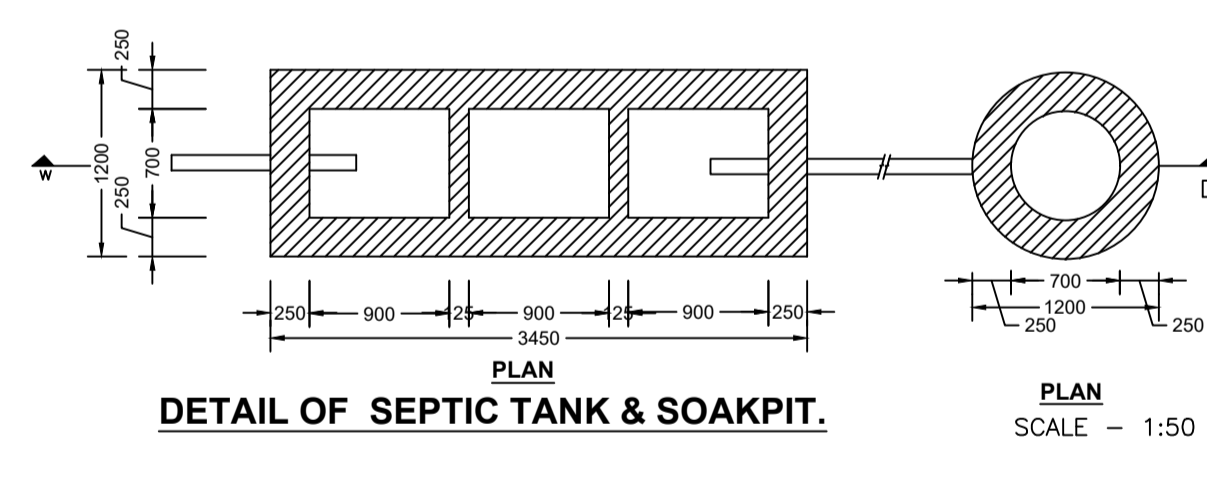

DETAIL OF SEPTIC TANK & SOAKPIT. PLAN SCALE - 1:50

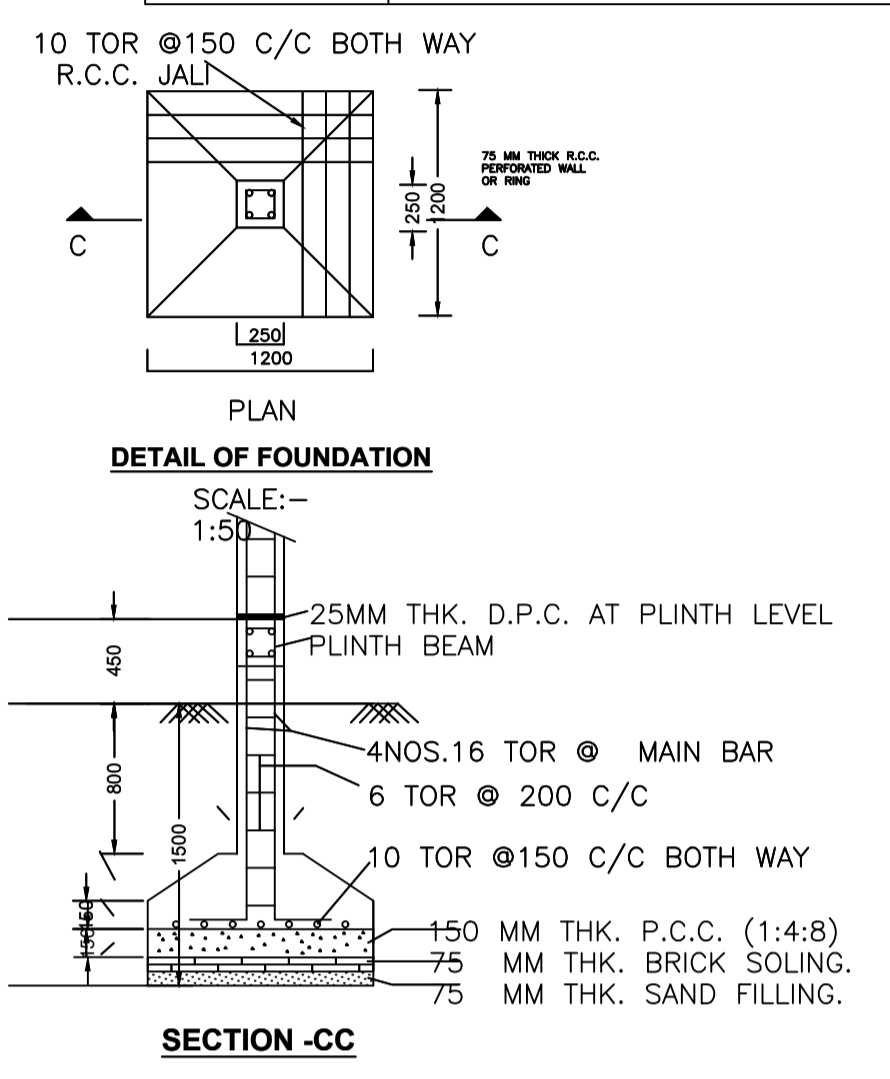

DETAIL OF FOUNDATION SECTION-CC

Proposal Basic Information

Proposal File No.	SINPC/BP/0418/W16/2023
Owner Name	EDWIN ENJRAS BECK
Khata No	93
Plot No	2081
Village Name	Simdega
Use	Residential
SubUse	Bungalow/ Dwelling / Non Apartment

Building :A (RESIDENCE)

Floor Name	Total Built Up Area (Sq.mt.)	Proposed FAR Area (Sq.mt.) Resi.	Total FAR Area (Sq.mt.)	Total Consumed Additional FAR Area (Sq.mt.)	Tnmt (No.)
Ground Floor	118.32	118.32	118.32	118.32	01
First Floor	118.32	118.32	118.32	118.32	00
Second Floor	118.32	118.32	118.32	118.32	00
Terrace Floor	0.00	0.00	0.00	0.00	00
Total:	354.96	354.96	354.96	354.96	01
Total Number of Same Buildings	1				
Total:	354.96	354.96	354.96	354.96	01

SCHEDULE OF DOOR:

BUILDING NAME	NAME	LENGTH	HEIGHT	NOS
A (RESIDENCE)	D2	0.76	2.10	04
A (RESIDENCE)	D1	0.91	2.10	03
A (RESIDENCE)	D	1.07	2.10	10

SCHEDULE OF WINDOW/VENTILATION:

BUILDING NAME	NAME	LENGTH	HEIGHT	NOS
A (RESIDENCE)	V	0.61	1.20	04
A (RESIDENCE)	W2	0.91	1.20	03
A (RESIDENCE)	W1	1.52	1.20	07
A (RESIDENCE)	W	1.83	1.20	02

UnitBUA Table for Building :A (RESIDENCE)

FLOOR	Name	UnitBUA Type	UnitBUA Area	Carpet Area	No. of Rooms	No. of Tenement
GROUND FLOOR PLAN	SPLIT A	FLAT	321.79	321.60	0	1
FIRST FLOOR PLAN	SPLIT A	FLAT	0.00	0.00	8	0
SECOND FLOOR PLAN	SPLIT A	FLAT	0.00	0.00	9	0
Total:	-	-	321.79	321.60	17	1

LTP NAME AND SIGNATURE	STRUCTURAL ENG'S NAME AND SIGNATURE	BUILDER NAME AND SIGNATURE	DIGITAL SIGNATURE
MAHENDRA MEHTA SINPC/DFTMN/0002/2022			

Proposal Basic Information	
Proposal File No.	SINPC/BP/0418/W16/2023
Owner Name	EDWIN ENJRAS BECK
Khata No	93
Plot No	2081
Village Name	Simdega
Use	Residential
SubUse	Bungalow/ Dwelling / Non Apartment

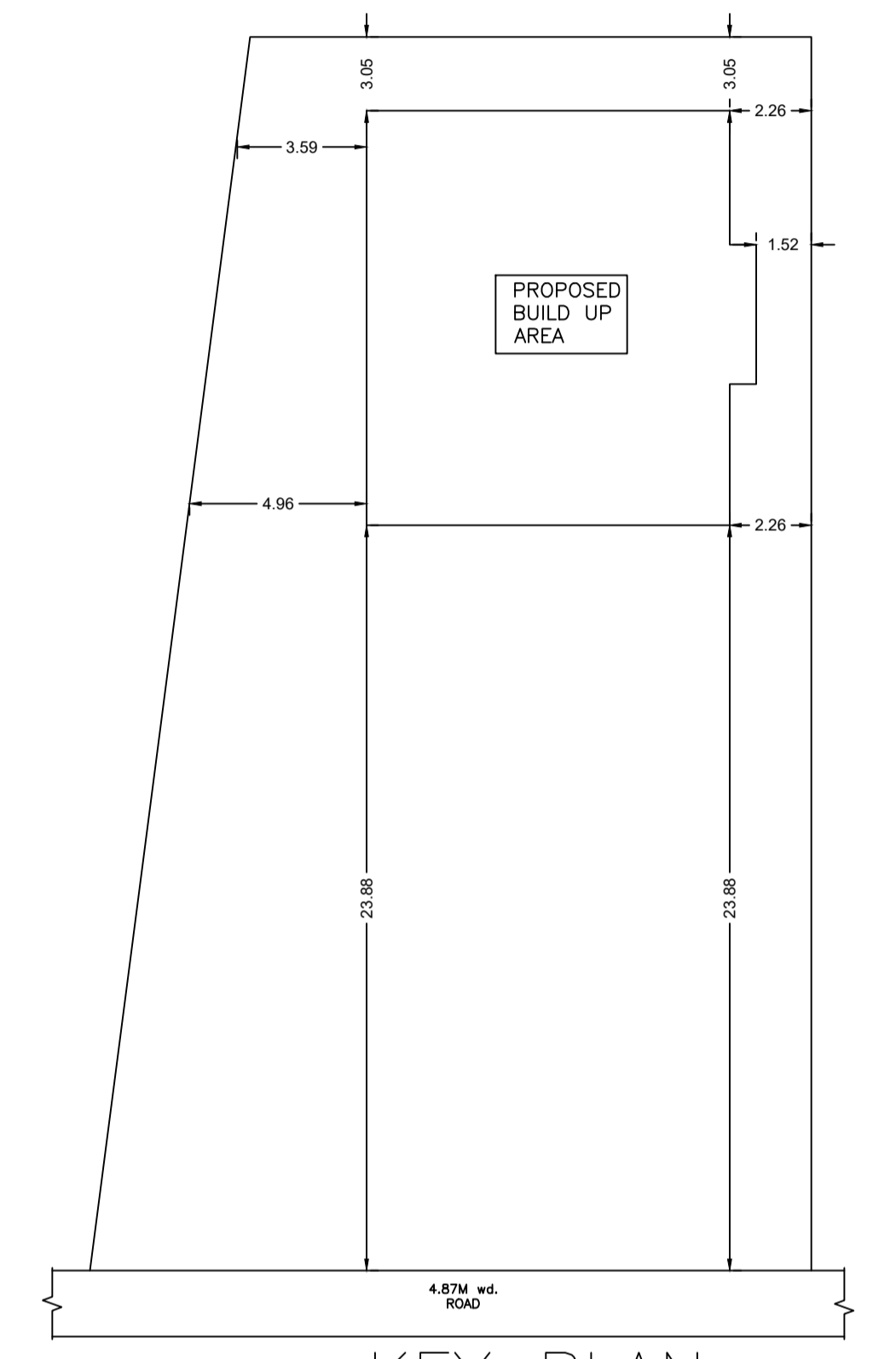

KEY PLAN
SCALE 1:200

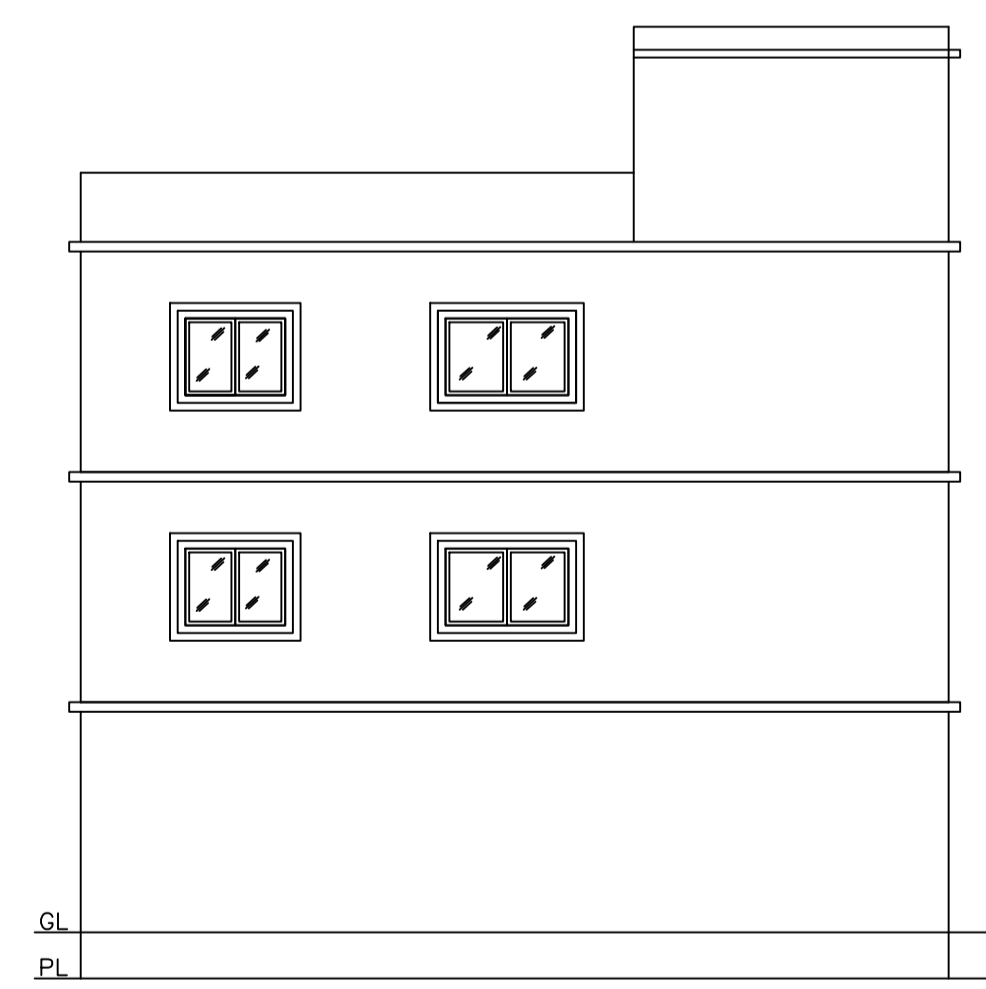

LEFT SIDE ELEVATION
SCALE 1:100

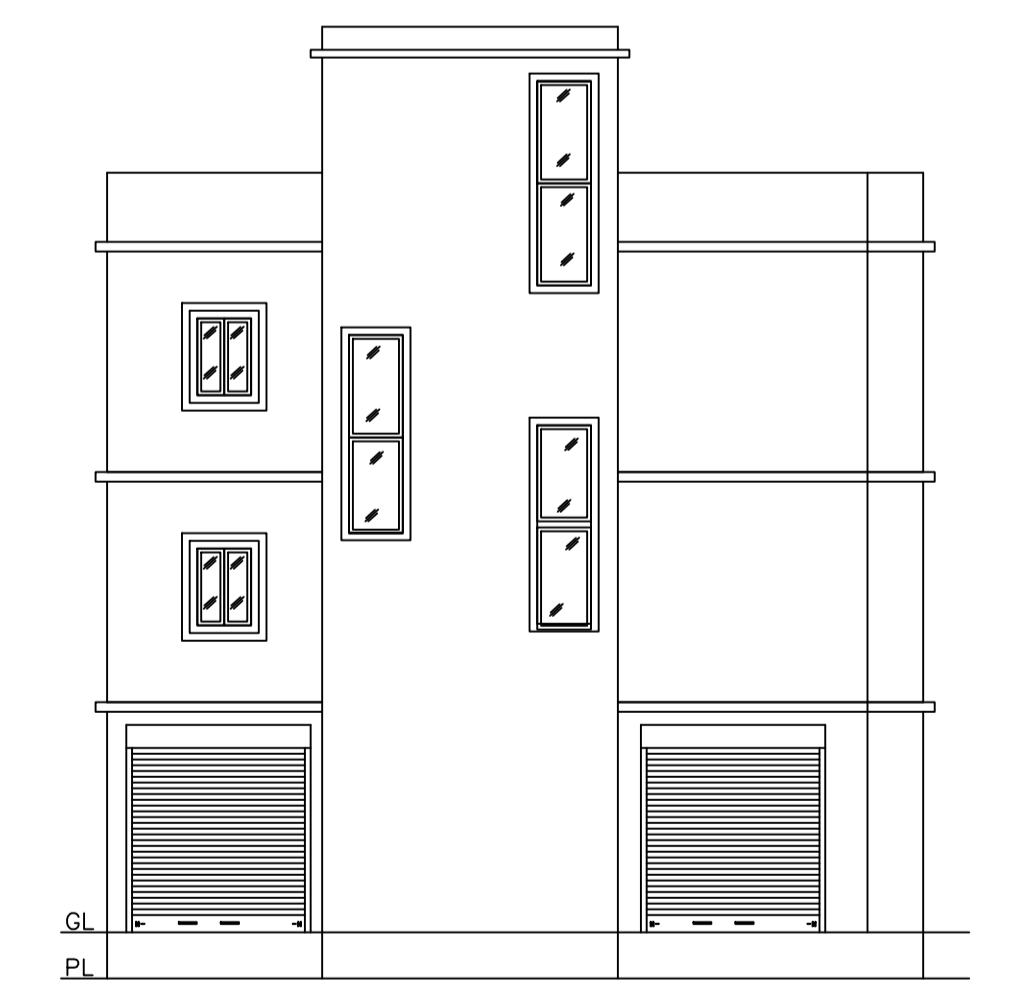

FRONT ELEVATION
SCALE 1:100

LTP NAME AND SIGNATURE	STRUCTURAL ENG'S NAME AND SIGNATURE	BUILDER NAME AND SIGNATURE	DIGITAL SIGNATURE
MAHENDRA MEHTA SINPC/DFTMN/0002/2022			