

SITE PLAN

FAR & Tenement Details (Table 4c-1)

Building	No. of Same Bldg	Total Built Up Area (Sq.mt.)	Deductions (Area in Sq.mt.)	Proposed FAR Area (Sq.mt.)	Total FAR Area (Sq.mt.)	Total Consumed Additional FAR Area (Sq.mt.)	Tnmt (No.)
A (RESIDENTIAL)	1	252.98	11.77	241.21	241.21	241.21	01
Grand Total :	1	252.98	11.77	241.21	241.21	241.21	01

Proposal Basic Information

Proposal File No.	SINPC/BP/0469/W06/2023
Owner Name	MANJULA MINZ
Khata No	168
Plot No	2706,2707
Village Name	Khijiri
Use	Residential
SubUse	Bungalow/ Dwelling / Non Apartment

AREA STATEMENT SIMDEGA NAGAR PANCHAYAT	VERSION NO: 1.0.68
PROJECT DETAIL:	VERSION DATE: 16/10/2020
Region: JHARKHAND URBAN LOCAL BODIES	Plot Use: Residential
District: SIMDEGA	Plot SubUse: Bungalow/ Dwelling / Non Apartment
Authority: SIMDEGA NAGAR PANCHAYAT	PlotNearbyReligiousStructure: NA
Inward No: SINPC/BP/0469/W06/2023	PlotSubPlot No: 2706,2707
Application Type: General Proposal	North: -
Project Type: Building Permission	South: -
Nature of Development: New	East: -
Location of Development Area: Old Area	West: -
AREA DETAILS:	SQ.MT.
AREA OF PLOT (Minimum)	(A) 465.93
Deduction for NetPlot Area	
Surrender Free of Cost	12.77
Total	12.77
NET AREA OF PLOT(Gross Plot Area - Deduction from Gross Plot area)	(A-Deductions) 453.17
Deduction for Balance Plot Area(from Gross Plot Area)	
Surrender Free of Cost	12.77
Common Plot	25.20
Total	37.97
BALANCE AREA OF PLOT(Net Plot Area - Recreational/Amenity space)	(A-Deductions) 427.96
PLOT AREA FOR COVERAGE(Net Plot Area)	(A-Deductions) 453.17
Plot Area for FAR (Net Plot Area + RoadWidening Area)	(A-Deductions) 465.93
COVERAGE CHECK	
Permissible Coverage area (60.00 %)	271.90
Proposed Coverage Area (27.04 %)	122.55
Total Prop. Coverage Area (27.04 %)	122.55
Balance coverage area (32.96 %)	149.35
FAR CHECK	
Perm. FAR Area (1.500)	698.90
Total Perm. FAR area	698.90
Residential FAR	241.21
Proposed FAR Area	241.21
Total Proposed FAR Area	241.21
Consumed FAR (Factor)	0.52
Balance FAR Area	457.69
BUILT UP AREA CHECK	
Total Proposed BuiltUp Area	252.98
ARCHITECT (Regd)	DEELIP KUMAR
ENGINEER (Regd)	
SUPERVISOR (Regd)	
OWNER (Regd)	MANJULA MINZ
DEVELOPMENT AUTHORITY	LOCAL BODY

COLOR INDEX	
PLOT BOUNDARY	Black
ABUTTING ROAD	Green
PROPOSED CONSTRUCTION	Red
COMMON PLOT	Yellow
ROAD WIDENING AREA	Blue
EXISTING (To be retained)	Blue
EXISTING (To be demolished)	Yellow

Buildingwise Floor FAR Details

Floor Name	Building Name A (RESIDENTIAL)		Total	
	Proposed Built Up Area (Sq.mt.)	Proposed FAR Area (Sq.mt.)	Total Proposed Built Up Area (Sq.mt.)	Total FAR Area (Sq.mt.)
Ground Floor	122.54	110.77	122.54	110.77
First Floor	130.44	130.44	130.44	130.44
Terrace Floor	0.00	0.00	0.00	0.00
Total :	252.98	241.21	252.98	241.21

Building USE/SUBUSE Details

Building Name	Building Use	Building SubUse	Building Structure
A (RESIDENTIAL)	Residential	Bungalow/ Dwelling / Non Apartment	Non-Highrise

LTP NAME AND SIGNATURE	STRUCTURAL ENG'S NAME AND SIGNATURE	BUILDER NAME AND SIGNATURE	DIGITAL SIGNATURE
DEELIP KUMAR SINPC/DFTMN/0003/2023			

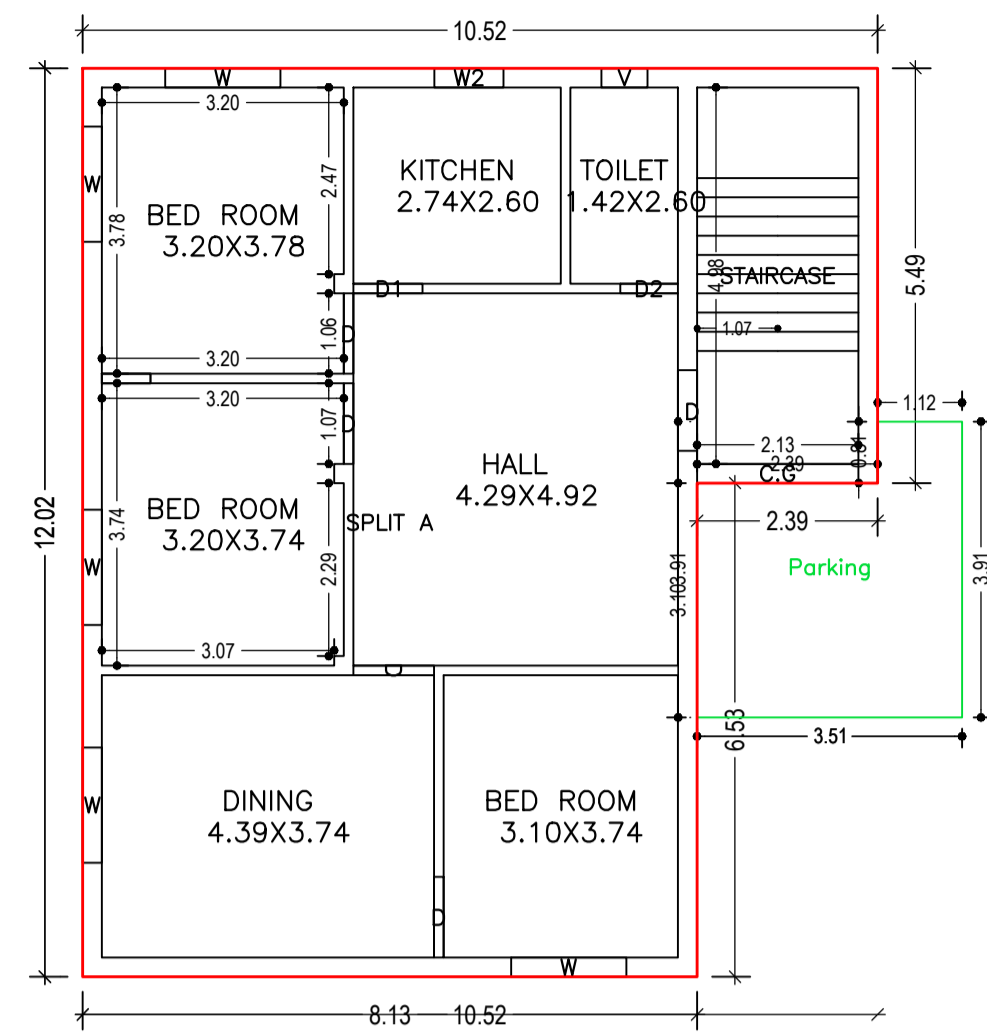

GROUND FLOOR PLAN (Proposed) (SCALE 1:100)

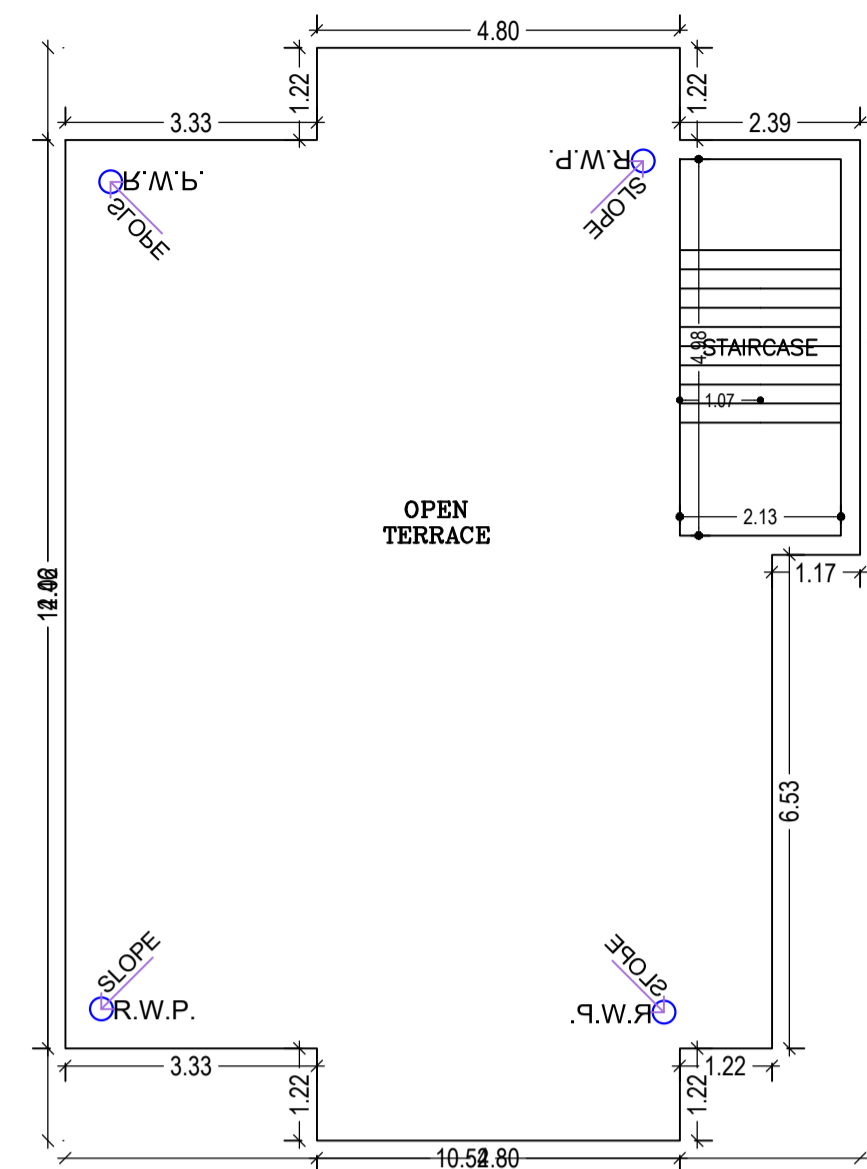

TERRACE FLOOR PLAN (SCALE 1:100)

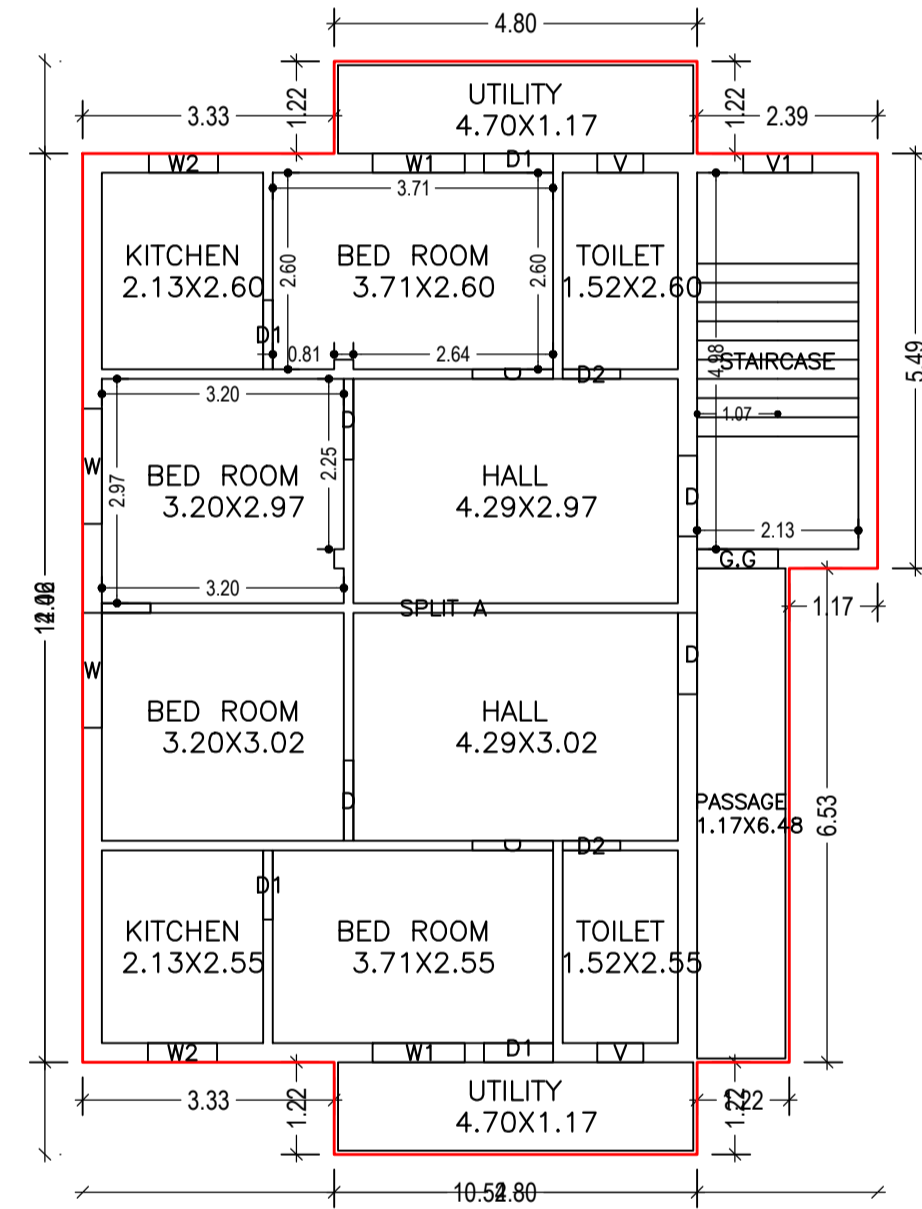

FIRST FLOOR PLAN (Proposed) (SCALE 1:100)

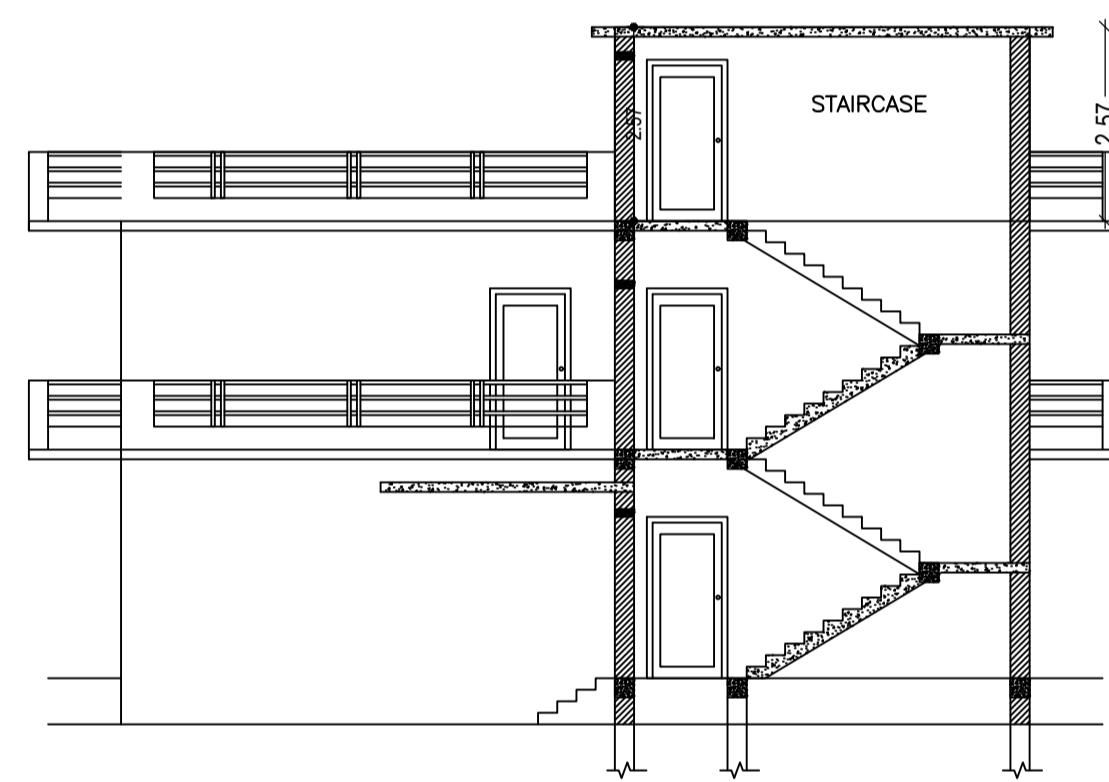

SECTION AT Y-Y' SCALE 1:100

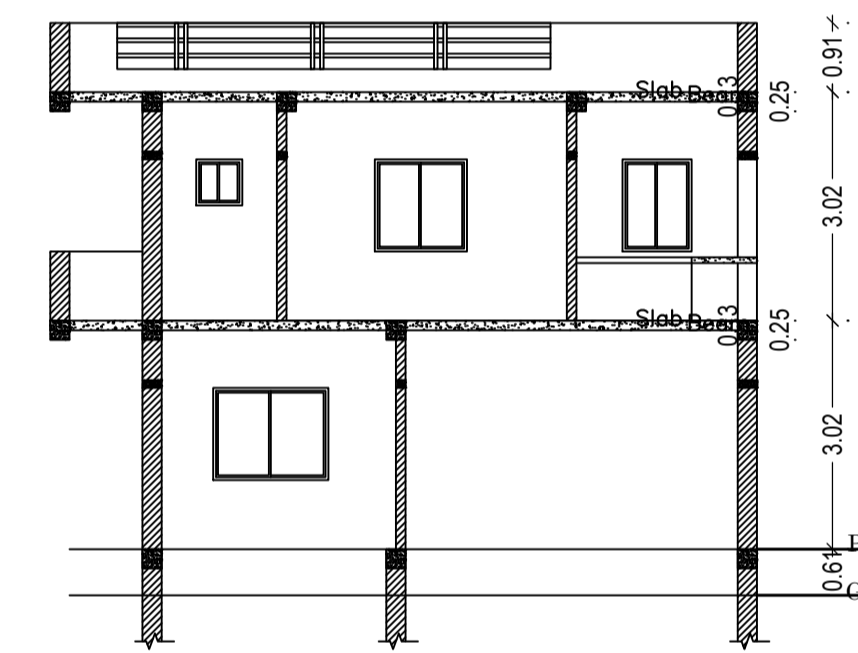

SECTION AT X-X' SCALE 1:100

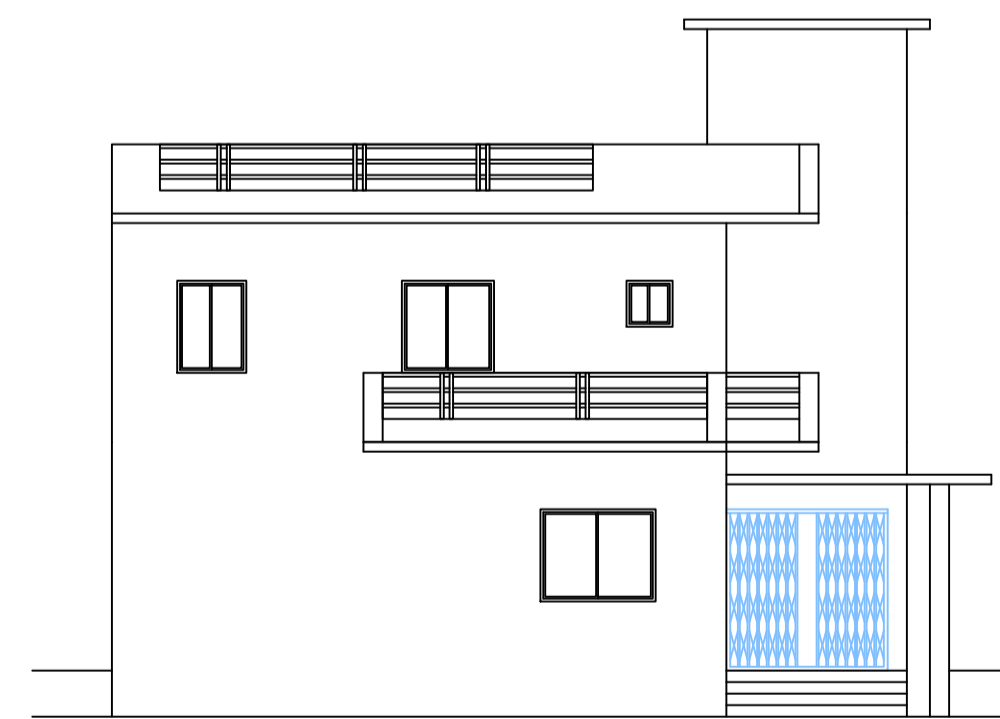

FRONT ELEVATION SCALE 1:100

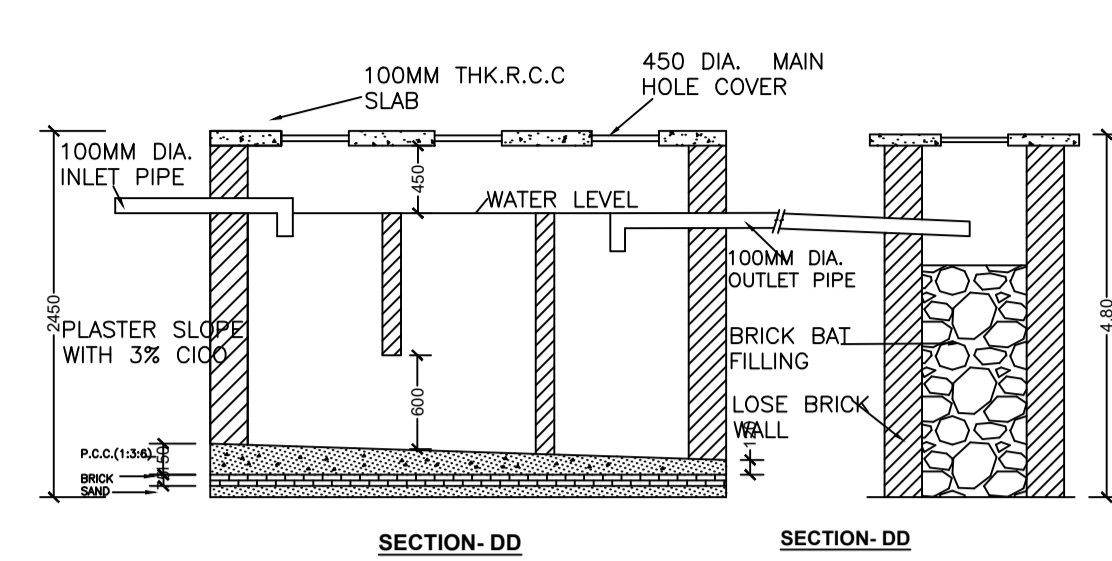

DETAIL OF SEPTIC TANK & SOAKPIT.

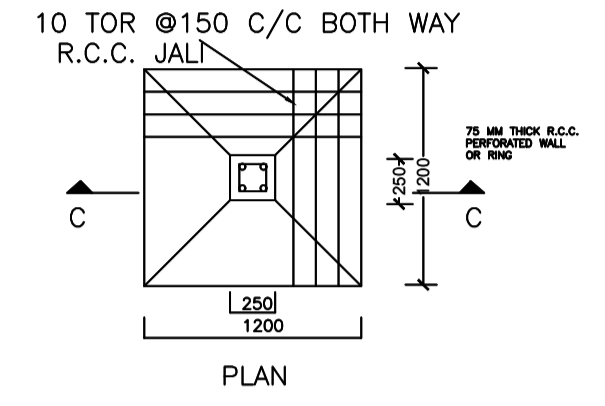

DETAIL OF FOUNDATION

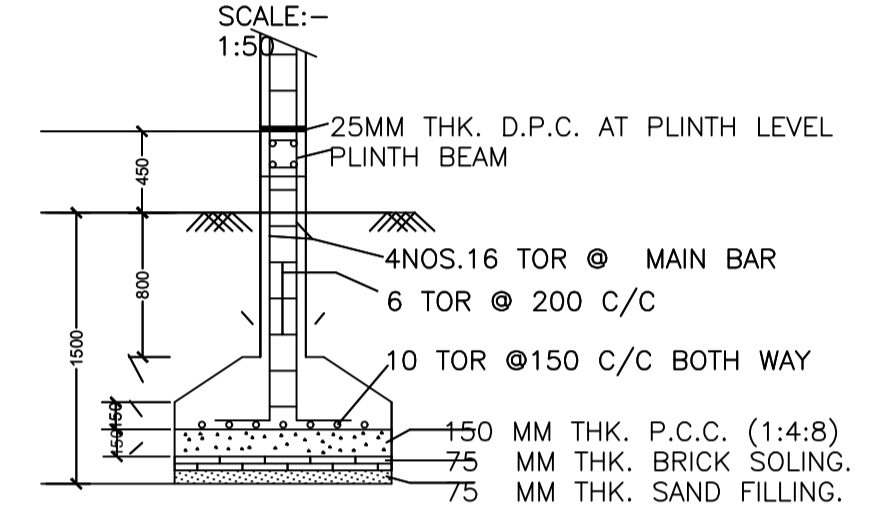

SECTION -CC

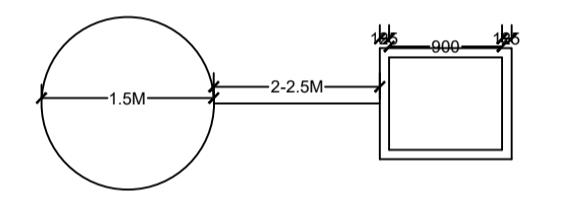

PLAN OF GROUND WATER RECHARGING PIT WITH SILT TANK

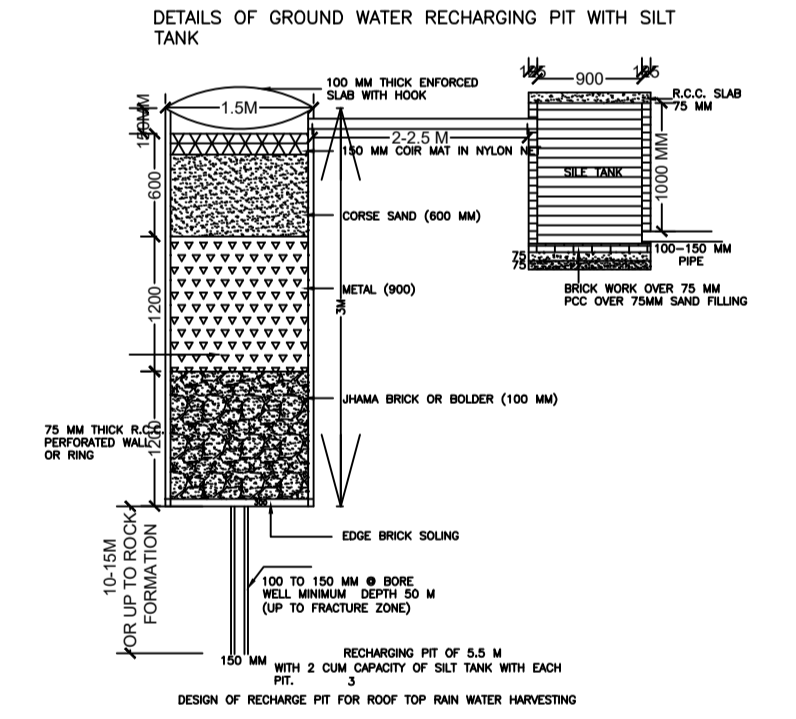

DETAILS OF GROUND WATER RECHARGING PIT WITH SILT TANK

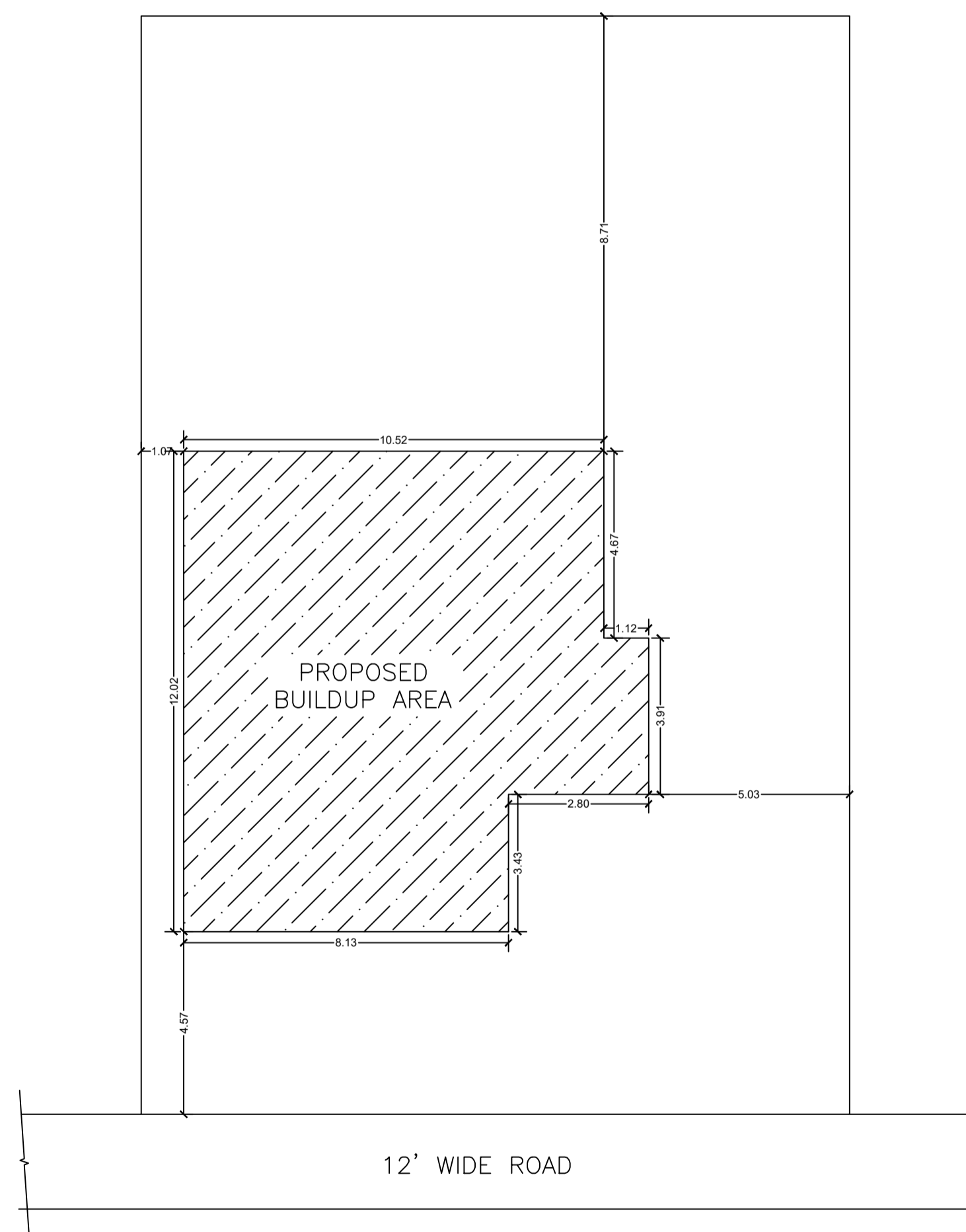

KEY PLAN SCALE 1:100

Floor Name	Total Built Up Area (Sq.mt.)	Deductions (Area in Sq.mt.)	Proposed FAR Area (Sq.mt.)	Total FAR Area (Sq.mt.)	Total Consumed Additional FAR Area (Sq.mt.)	Trmt (No.)
Ground Floor	122.54	11.77	110.77	110.77	110.77	01
First Floor	130.44	0.00	130.44	130.44	130.44	00
Terrace Floor	0.00	0.00	0.00	0.00	0.00	00
Total:	252.98	11.77	241.21	241.21	241.21	01
Total Number of Same Buildings	1					
Total:	252.98	11.77	241.21	241.21	241.21	01

SCHEDULE OF DOOR:

BUILDING NAME	NAME	LENGTH	HEIGHT	NOS
A (RESIDENTIAL)	D2	0.76	2.10	03
A (RESIDENTIAL)	D1	0.91	2.10	05
A (RESIDENTIAL)	D	1.06	2.10	02
A (RESIDENTIAL)	D	1.07	2.10	08
A (RESIDENTIAL)	G.G	1.07	2.10	01
A (RESIDENTIAL)	D	1.08	2.10	01

SCHEDULE OF WINDOW/VENTILATION:

BUILDING NAME	NAME	LENGTH	HEIGHT	NOS
A (RESIDENTIAL)	V	0.61	1.20	03
A (RESIDENTIAL)	W2	0.91	1.20	03
A (RESIDENTIAL)	V1	0.91	1.20	01
A (RESIDENTIAL)	W1	1.22	1.20	02
A (RESIDENTIAL)	W	1.52	1.20	07

UnitBUA Table for Building :A (RESIDENTIAL)

FLOOR	Name	UnitBUA Type	UnitBUA Area	Carpet Area	No. of Rooms	No. of Tenement
GROUND FLOOR PLAN	SPLIT A	FLAT	197.88	197.72	7	1
FIRST FLOOR PLAN	SPLIT A	FLAT	0.00	0.00	13	0
Total:	-	-	197.88	197.72	20	1

LTP NAME AND SIGNATURE	STRUCTURAL ENG'S NAME AND SIGNATURE	BUILDER NAME AND SIGNATURE	DIGITAL SIGNATURE
DEELIP KUMAR SINPC/DFTMN/0003/2023			

Proposal Basic Information	
Proposal File No.	SINPC/BP/0489/W06/2023
Owner Name	MANJULA MINZ
Khata No	168
Plot No	2706,2707
Village Name	Khijiri
Use	Residential
SubUse	Bungalow/ Dwelling / Non Apartment

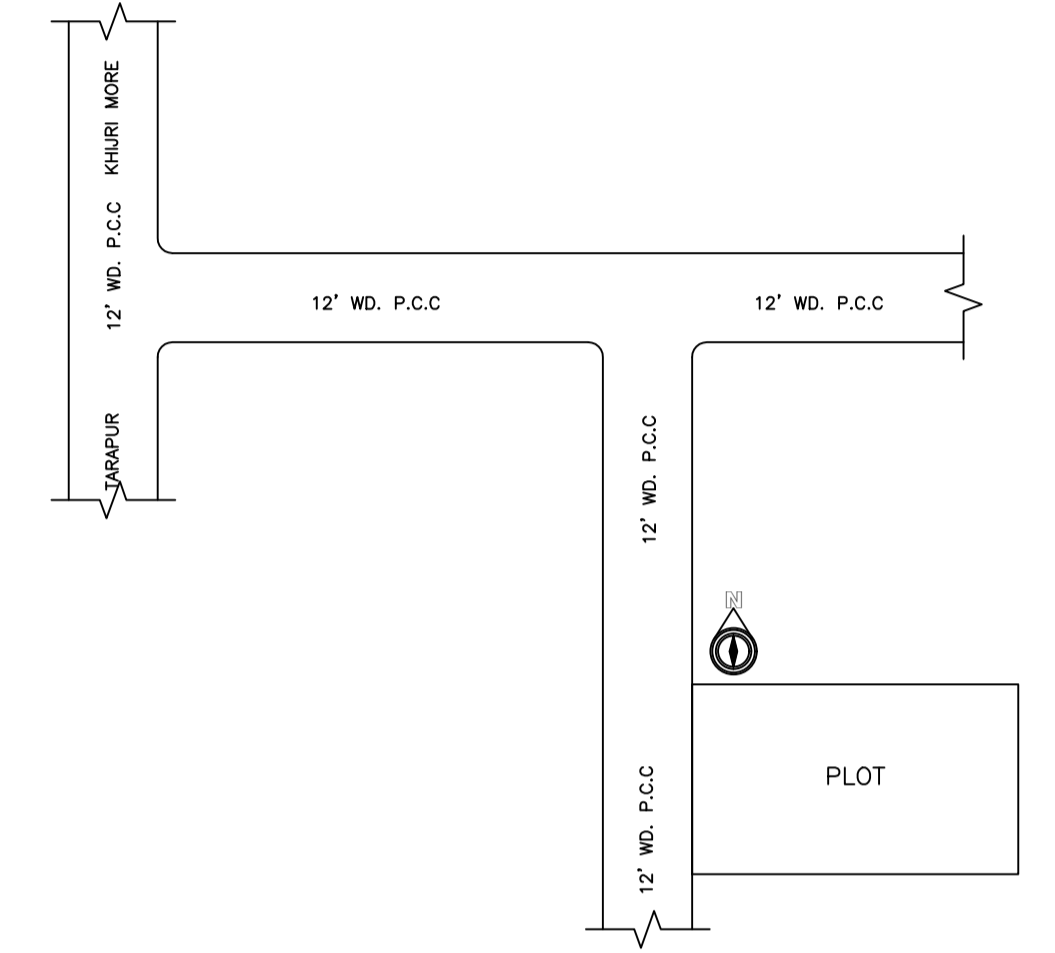

LOCATION PLAN
NOT TO SCALE

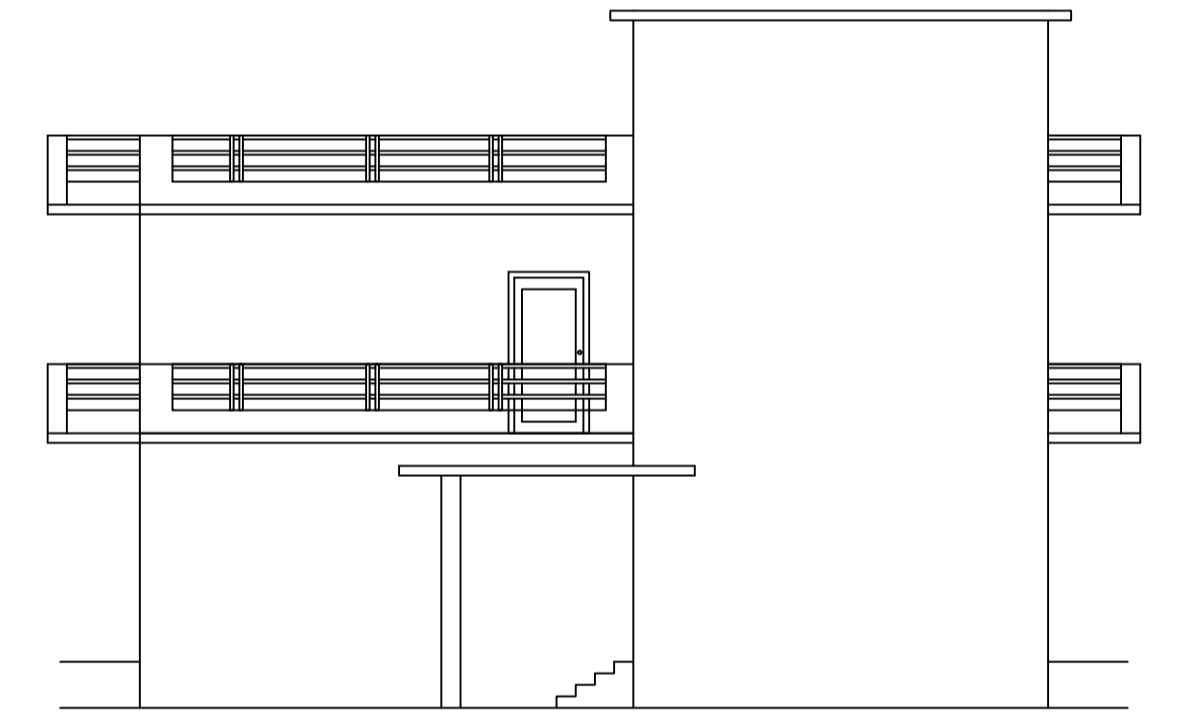

RIGHT SIDE ELEVATION
SCALE 1:100

LTP NAME AND SIGNATURE	STRUCTURAL ENG'S NAME AND SIGNATURE	BUILDER NAME AND SIGNATURE	DIGITAL SIGNATURE
DEELIP KUMAR SINPC/DFTMN/0003/2023			