

FAR & Tenement Details (Table 4c-1)

Building	No. of Same Bldg	Total Built Up Area (Sq.mt.)	Proposed FAR Area (Sq.mt.) Resi.	Total FAR Area (Sq.mt.)	Total Consumed Additional FAR Area (Sq.mt.)	Tnmt (No.)
A (BUILDING)	1	175.08	175.08	175.08	175.08	01
Grand Total :	1	175.08	175.08	175.08	175.08	01

Proposal Basic Information

Proposal File No.	SINPC/BP/0525/W06/2024
Owner Name	FULJENCIA BILUNG
Khata No	99
Plot No	2394
Village Name	Khijri
Use	Residential
SubUse	Bungalow/ Dwelling / Non Apartment

AREA STATEMENT SIMDEGA NAGAR PANCHAYAT	VERSION NO. : 1.0.70
PROJECT DETAIL:	VERSION DATE: 16/10/2020
Region: JHARKHAND URBAN LOCAL BODIES	Plot Use: Residential
District: SIMDEGA	Plot SubUse: Bungalow/ Dwelling / Non Apartment
Authority: SIMDEGA NAGAR PANCHAYAT	PlotNearbyReligiousStructure: NA
Inward No: SINPC/BP/0525/W06/2024	PlotSubPlot No: 2394
Application Type: General Proposal	North: Plot No. - SUSHULA DEVI HOUSE
Project Type: Building Permission	South: Plot No. - 2394
Nature of Development: New	East: Plot No. - 2394
Location of Development Area: Old Area	West: Road Width - 3.6
AREA DETAILS:	SQ.MT.
AREA OF PLOT (Minimum)	(A) 296.92
Deduction for NetPlot Area	
Road Widening Area	17.57
Total	17.57
NET AREA OF PLOT(Gross Plot Area - Deduction from Gross Plot area)	(A-Deductions) 279.35
Deduction for Balance Plot Area(from Gross Plot Area)	
Road Widening Area	17.57
Common Plot	35.53
Total	53.10
BALANCE AREA OF PLOT(Net Plot Area - Recreational/Amenity space)	(A-Deductions) 243.82
PLOT AREA FOR COVERAGE(Net Plot Area)	(A-Deductions) 279.35
Plot Area for FAR (Net Plot Area + RoadWidening Area)	(A-Deductions) 279.35
COVERAGE CHECK	
Permissible Coverage area (60.00 %)	167.61
Proposed Coverage Area (31.34 %)	87.54
Total Prop. Coverage Area (31.34 %)	87.54
Balance coverage area (28.66 %)	80.07
FAR CHECK	
Perm. FAR Area (1.500)	419.03
Total Perm. FAR area	419.03
Residential FAR	175.09
Proposed FAR Area	175.09
Total Proposed FAR Area	175.09
Consumed FAR (Factor)	0.63
Balance FAR Area	243.94
BUILT UP AREA CHECK	
Total Proposed BuiltUp Area	175.08
ARCHITECT (Regd)	vivek raj gupta
ENGINEER (Regd)	
SUPERVISOR (Regd)	
OWNER (Regd)	FULJENCIA BILUNG
DEVELOPMENT AUTHORITY	LOCAL BODY

COLOR INDEX	
PLOT BOUNDARY	Black
ABUTTING ROAD	Green
PROPOSED CONSTRUCTION	Red
COMMON PLOT	Yellow
ROAD WIDENING AREA	Orange
EXISTING (To be retained)	Blue
EXISTING (To be demolished)	Light Blue

Buildingwise Floor FAR Details

Floor Name	Building Name A (BUILDING)		Total	
	Proposed Built Up Area (Sq.mt.)	Proposed FAR Area (Sq.mt.)	Total Proposed Built Up Area (Sq.mt.)	Total FAR Area (Sq.mt.)
Ground Floor	87.54	87.54	87.54	87.54
First Floor	87.54	87.54	87.54	87.54
Terrace Floor	0.00	0.00	0.00	0.00
Total	175.08	175.08	175.08	175.08

Building USE/SUBUSE Details

Building Name	Building Use	Building SubUse	Building Structure
A (BUILDING)	Residential	Bungalow/ Dwelling / Non Apartment	Non-Highrise

SITE PLAN

LTP NAME AND SIGNATURE	STRUCTURAL ENG'S NAME AND SIGNATURE	BUILDER NAME AND SIGNATURE	DIGITAL SIGNATURE
vivek raj gupta SINPC/ENG/0001/2022			

Proposal Basic Information

Proposal File No.	SINPC/BP/0525/W06/2024
Owner Name	FULJENCIA BILUNG
Khata No	99
Plot No	2394
Village Name	Khijri
Use	Residential
SubUse	Bungalow/ Dwelling / Non Apartment

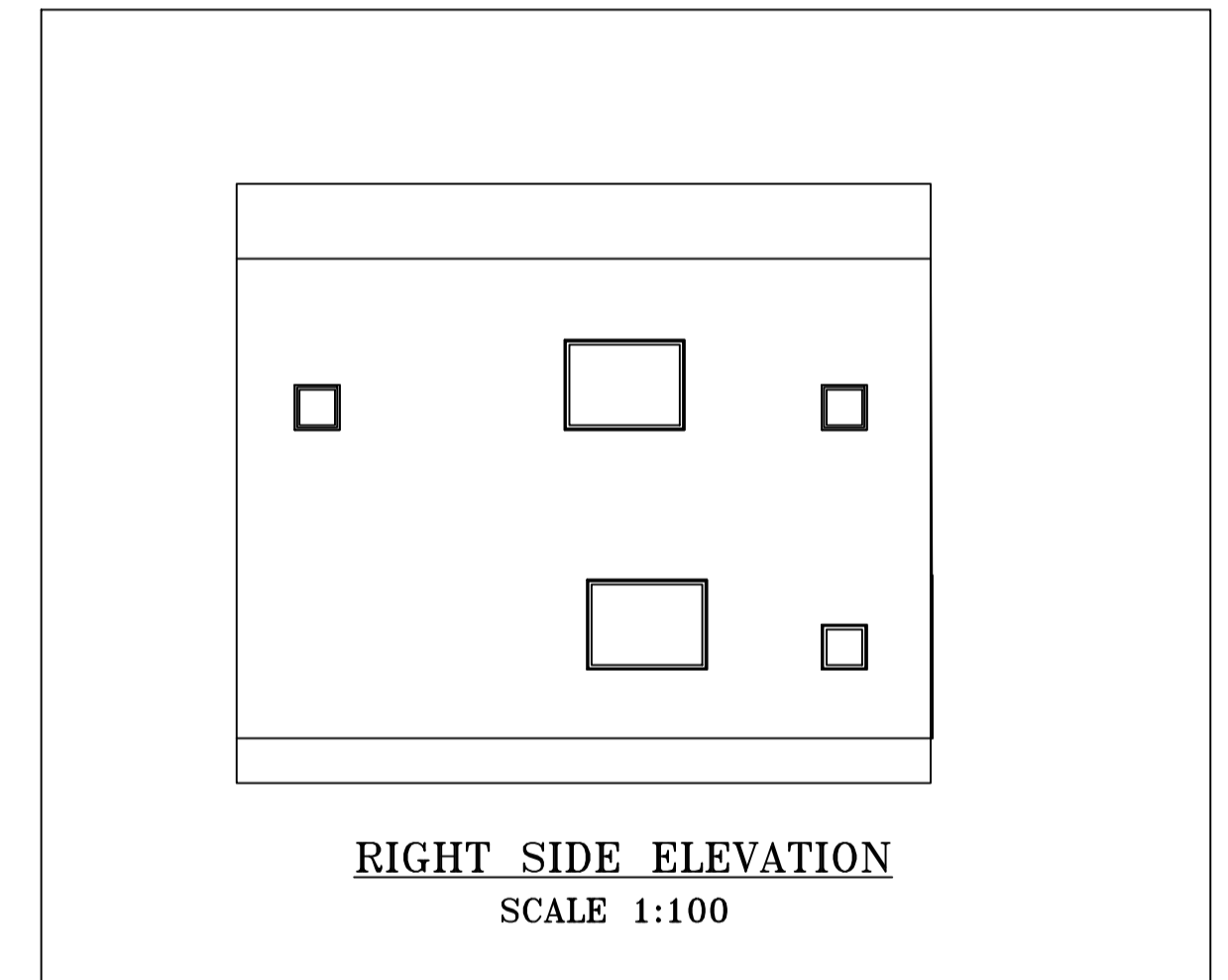
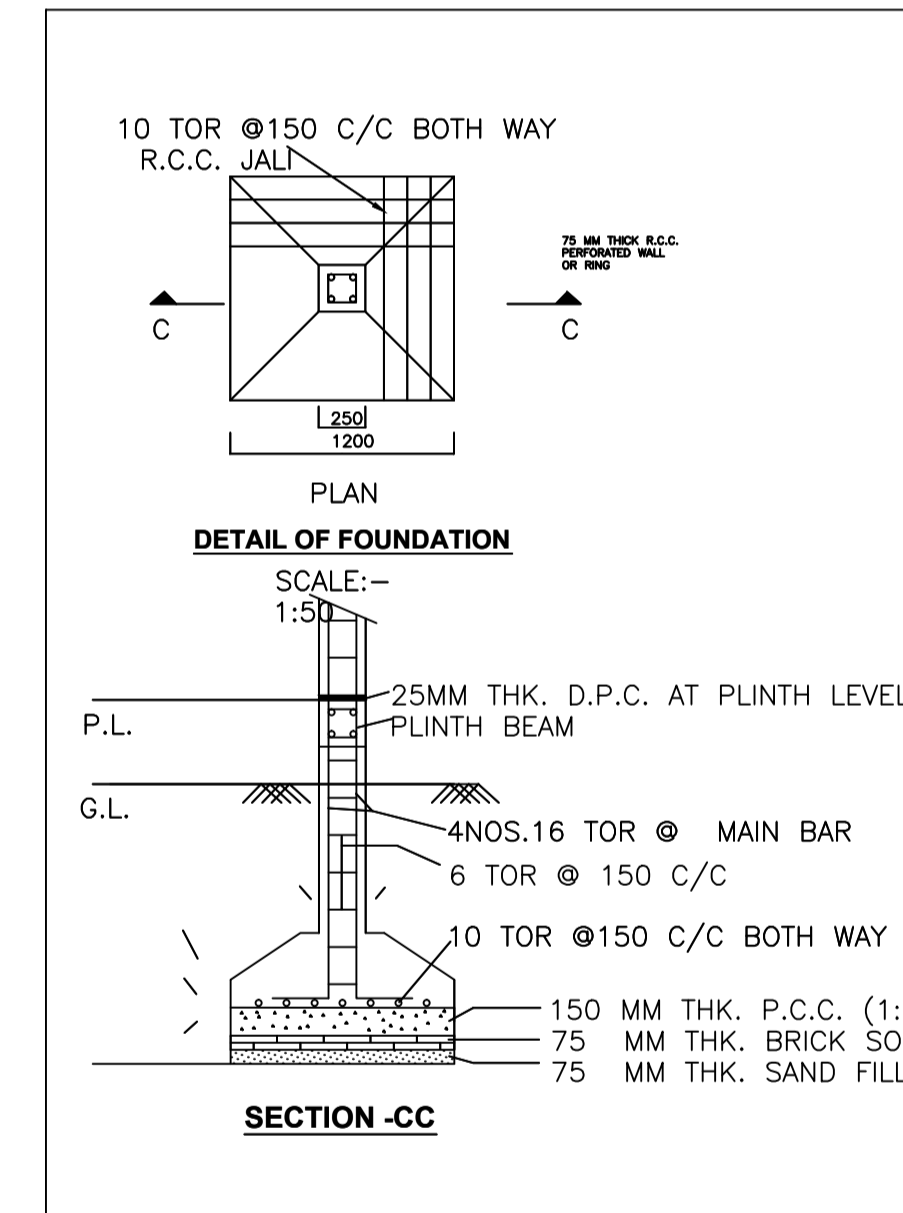
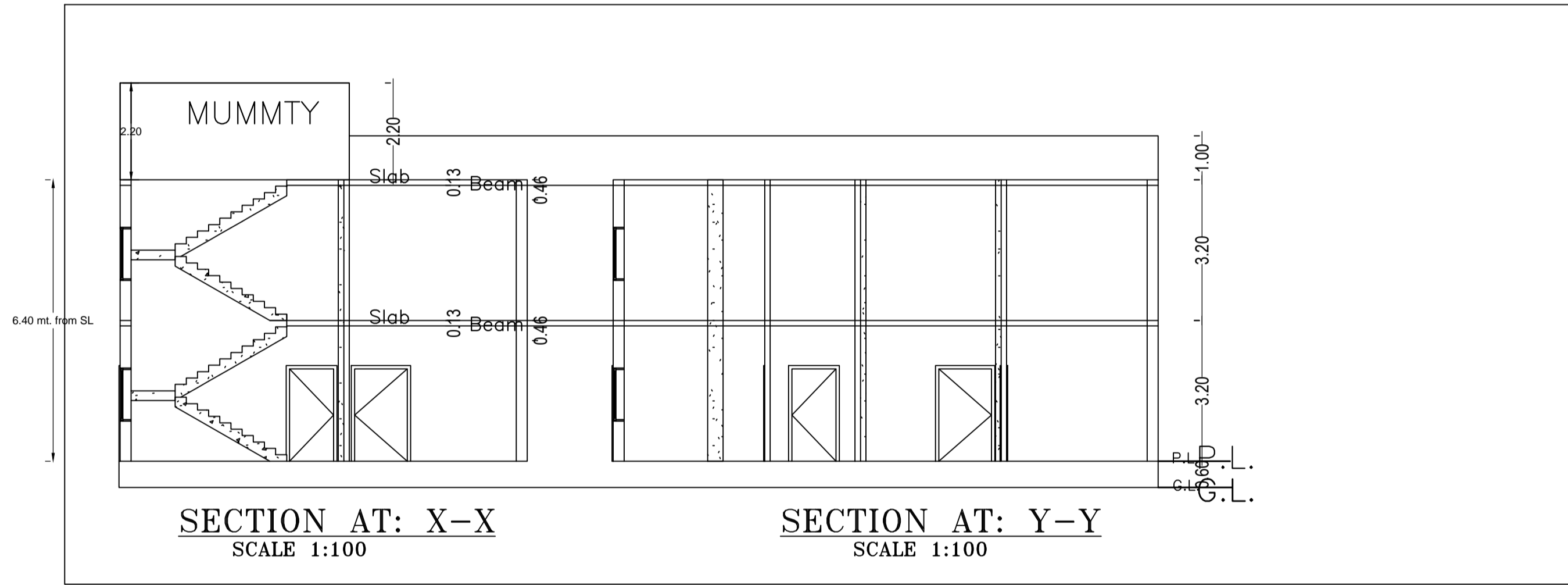
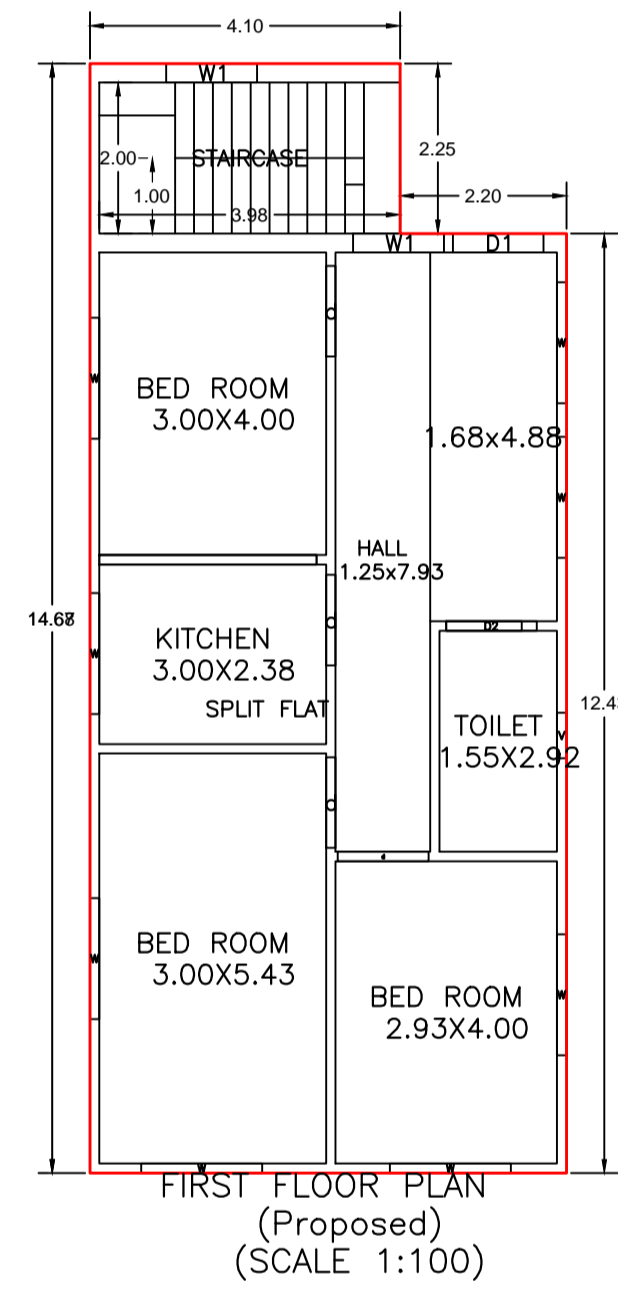
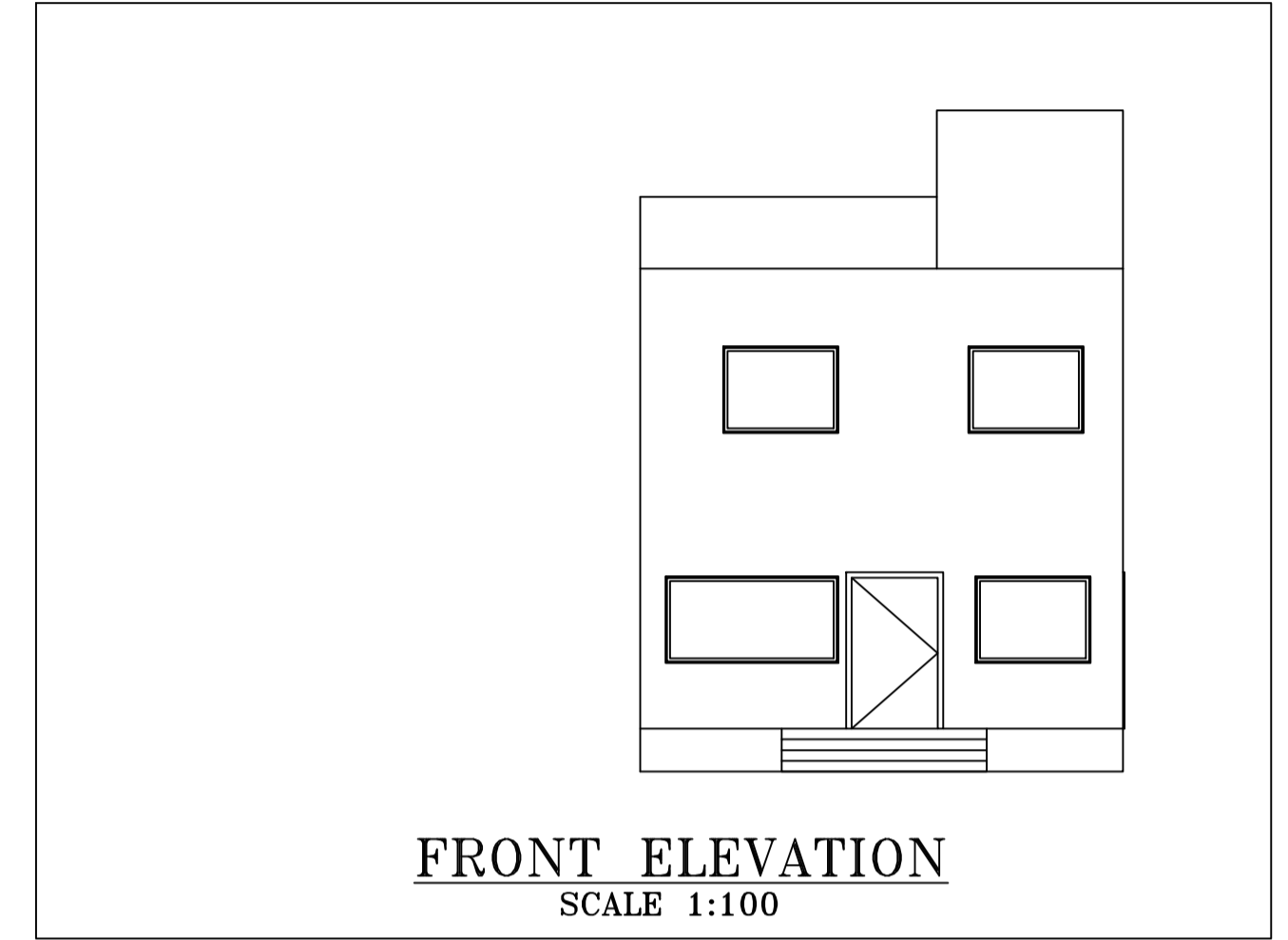
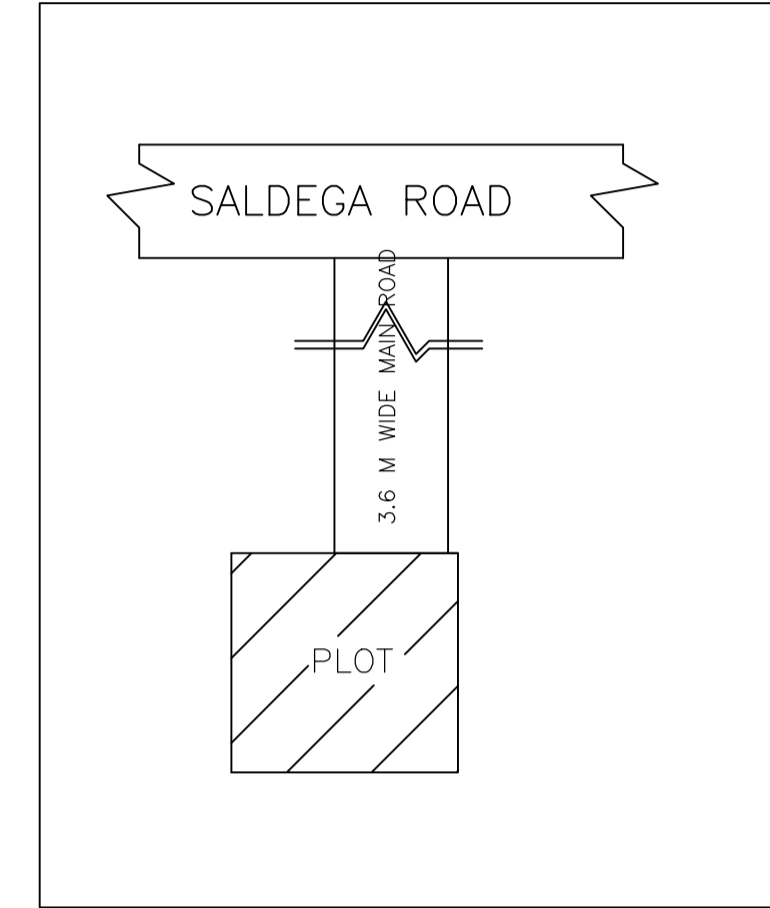
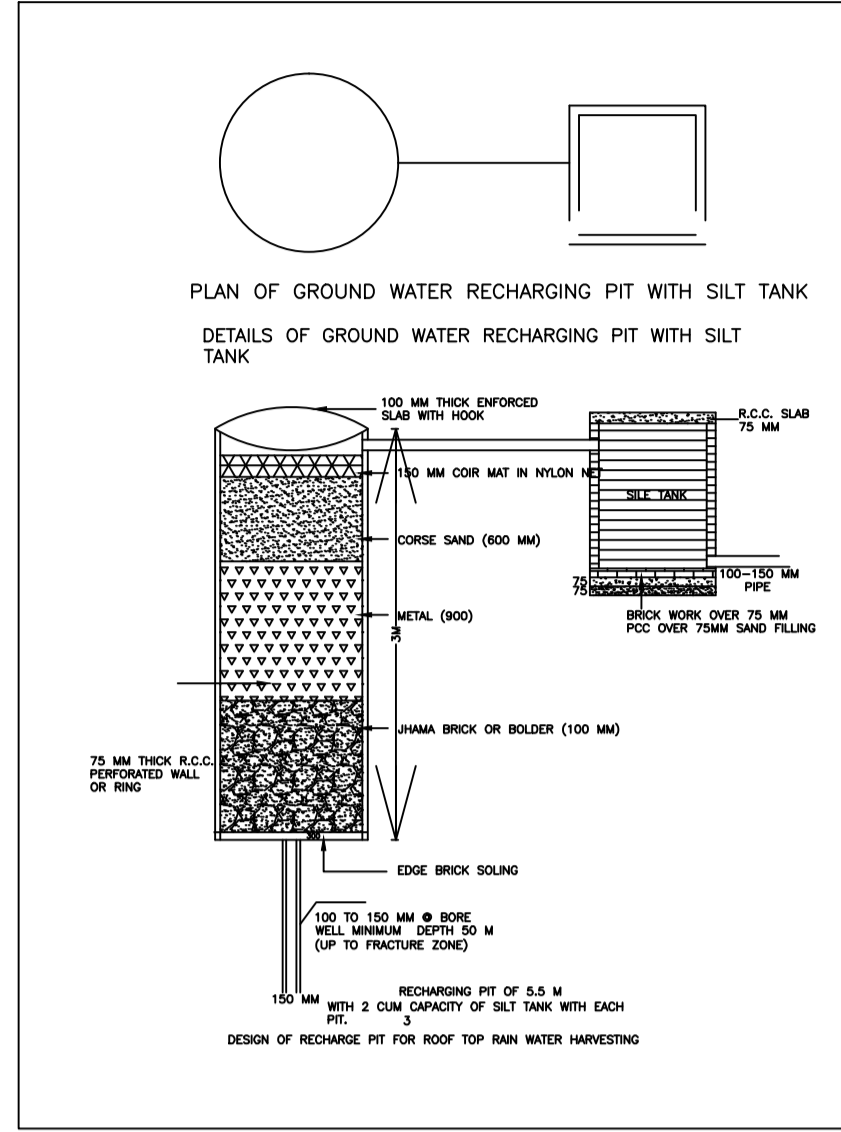
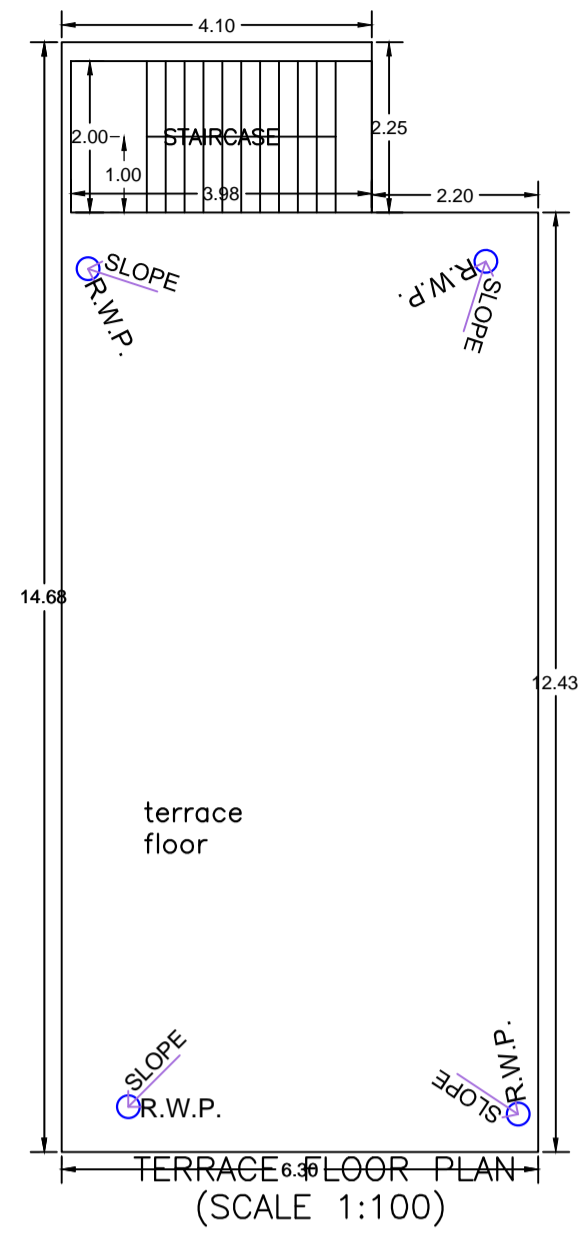
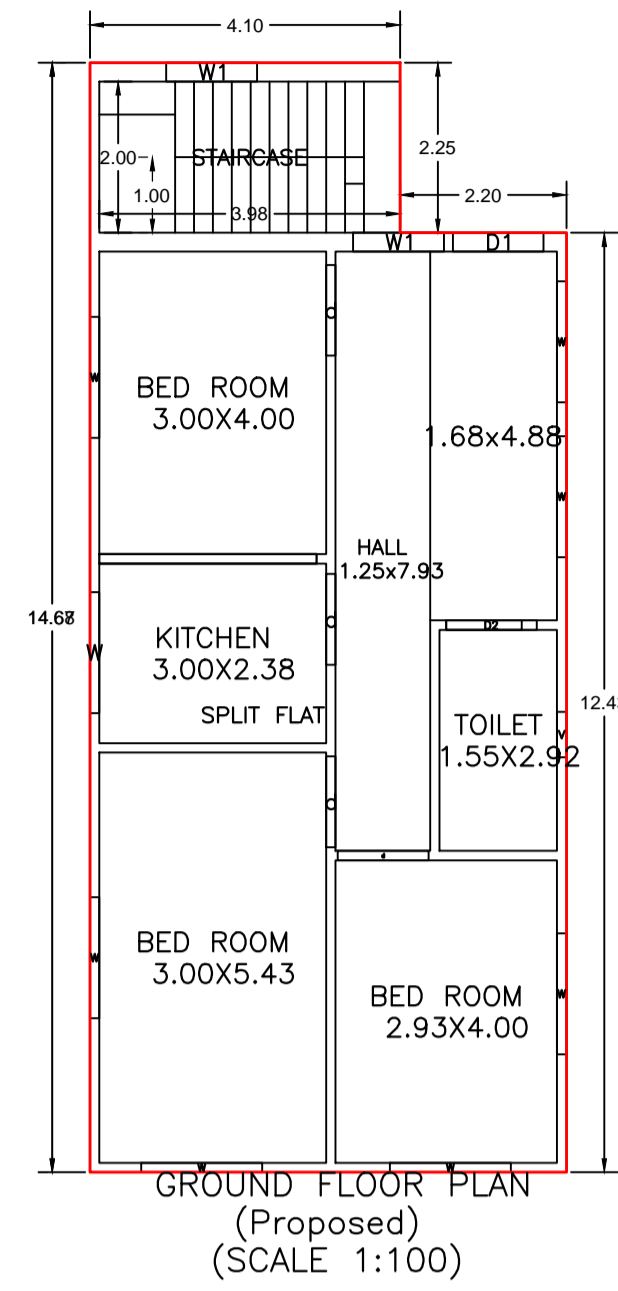

Building :A (BUILDING)

Floor Name	Total Built Up Area (Sq.mt.)	Proposed FAR Area (Sq.mt.)	Total FAR Area (Sq.mt.)	Total Consumed Additional FAR Area (Sq.mt.)	Tnmt (No.)
Ground Floor	87.54	87.54	87.54	87.54	01
First Floor	87.54	87.54	87.54	87.54	00
Terrace Floor	0.00	0.00	0.00	0.00	00
Total:	175.08	175.08	175.08	175.08	01
Total Number of Same Buildings	1				
Total:	175.08	175.08	175.08	175.08	01

SCHEDULE OF DOOR:

BUILDING NAME	NAME	LENGTH	HEIGHT	NOS
A (BUILDING)	D2	1.00	2.10	02
A (BUILDING)	d	1.20	2.10	08
A (BUILDING)	D2	1.20	2.10	02
A (BUILDING)	D1	1.20	2.10	02

SCHEDULE OF WINDOW/VENTILATION:

BUILDING NAME	NAME	LENGTH	HEIGHT	NOS
A (BUILDING)	V	0.60	0.60	02
A (BUILDING)	W1	1.20	1.20	04
A (BUILDING)	W	1.60	1.20	16

UnitBUA Table for Building :A (BUILDING)

FLOOR	Name	UnitBUA Type	UnitBUA Area	Carpet Area	No. of Rooms	No. of Tenement
GROUND FLOOR PLAN	SPLIT FLAT	FLAT	145.88	145.16	6	1
FIRST FLOOR PLAN	SPLIT FLAT	FLAT	0.00	0.00	6	0
Total:	-	-	145.88	145.16	12	1

LTP NAME AND SIGNATURE	STRUCTURAL ENG'S NAME AND SIGNATURE	BUILDER NAME AND SIGNATURE	DIGITAL SIGNATURE
vivek raj gupta SINPC/ENG/0001/2022			

Proposal Basic Information

Proposal File No.	SINPC/BP/0525/W06/2024
Owner Name	FULJENCIA BILUNG
Khata No	99
Plot No	2394
Village Name	Khijri
Use	Residential
SubUse	Bungalow/ Dwelling / Non Apartment

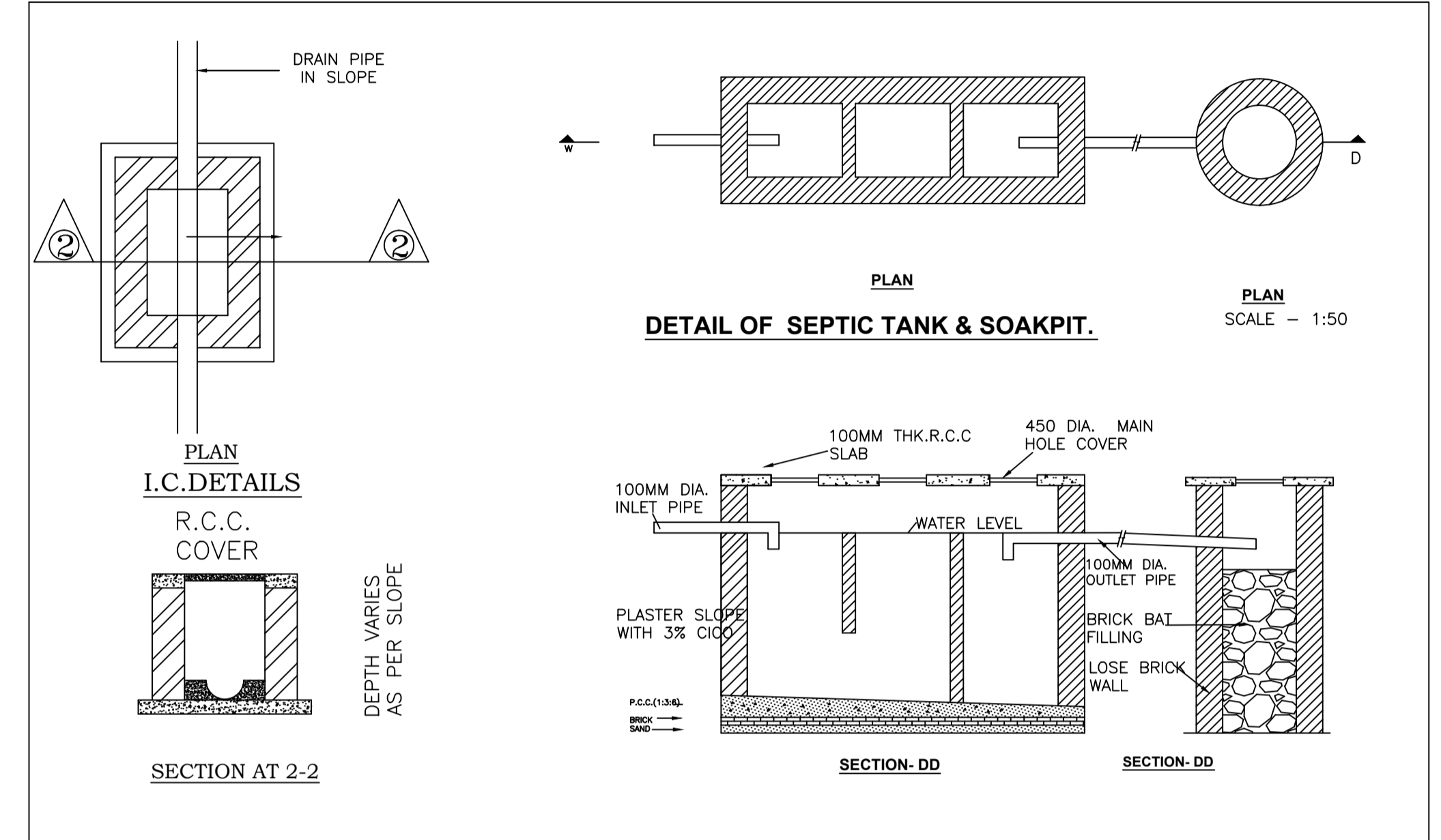
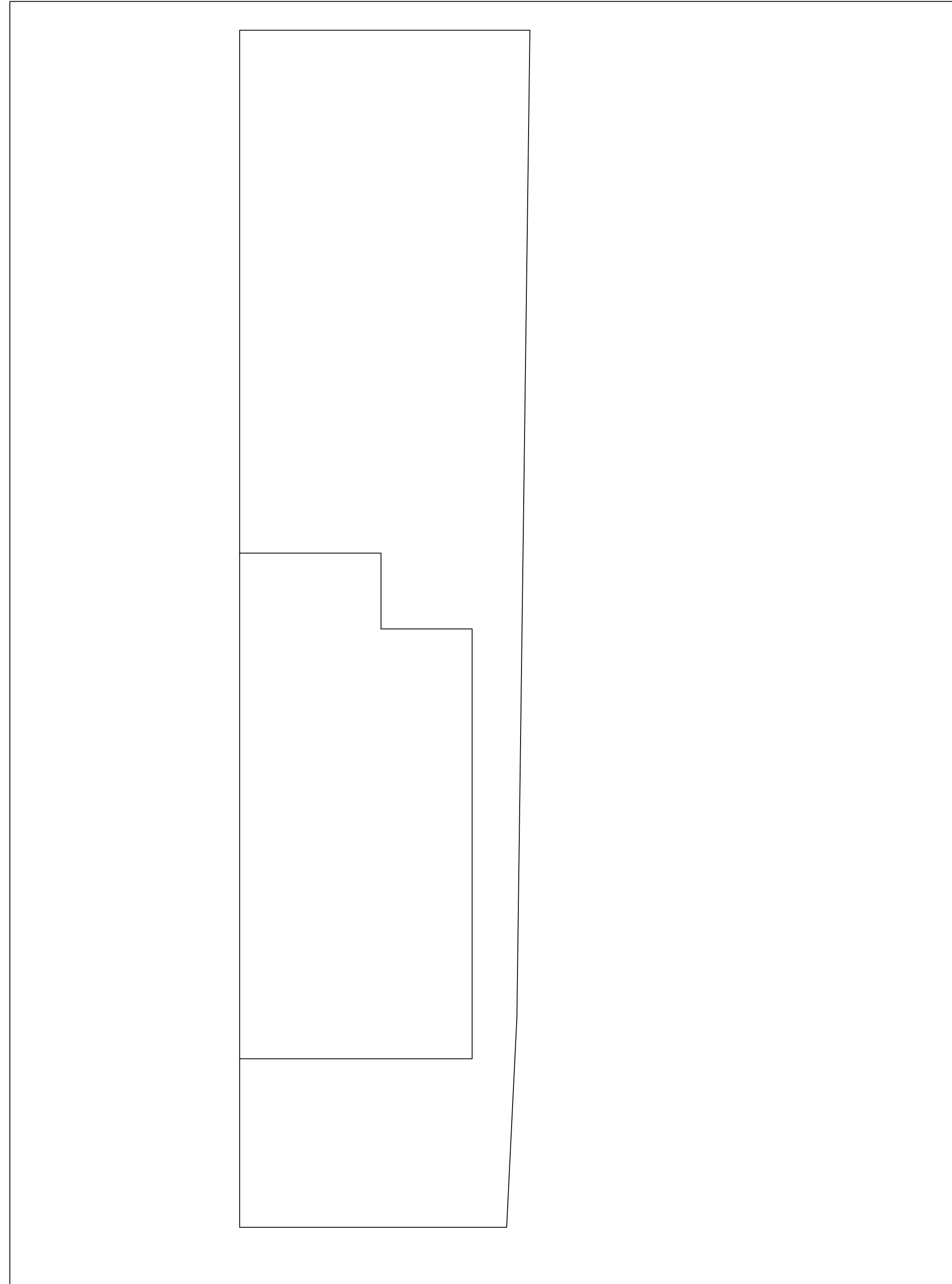

LTP NAME AND SIGNATURE	STRUCTURAL ENG'S NAME AND SIGNATURE	BUILDER NAME AND SIGNATURE	DIGITAL SIGNATURE
vivek raj gupta SINPC/ENG/0001/2022			