

Proposal Basic Information

Proposal File No.	SINPC/BP/0518/W04/2024
Owner Name	DAVID KANDULNA JOHN KANDULNA
Khata No	73
Plot No	1393
Village Name	Saldega
Use	Residential
SubUse	Bungalow/ Dwelling / Non Apartment

AREA STATEMENT SIMDEGA NAGAR PANCHAYAT		VERSION NO: 1.0.70
PROJECT DETAIL:		VERSION DATE: 16/10/2020
Region: JHARKHAND URBAN LOCAL BODIES	Plot Use: Residential	
District: SIMDEGA	Plot SubUse: Bungalow/ Dwelling / Non Apartment	
Authority: SIMDEGA NAGAR PANCHAYAT	PlotNearbyReligiousStructure: NA	
Inward No: SINPC/BP/0518/W04/2024	PlotSubPlot No: 1393	
Application Type: General Proposal	North: -	
Project Type: Building Permission	South: -	
Nature of Development: New	East: -	
Location of Development Area: Old Area	West: -	
AREA DETAILS:		
AREA OF PLOT (Minimum)	(A)	SQ.MT. 1214.15
Deduction for NetPlot Area		
Surrender Free of Cost		110.64
Total		110.64
NET AREA OF PLOT(Gross Plot Area - Deduction from Gross Plot area)		
(A-Deductions)		1103.51
Deduction for Balance Plot Area(from Gross Plot Area)		
Surrender Free of Cost		110.64
Common Plot		55.52
Total		166.16
BALANCE AREA OF PLOT(Net Plot Area - Recreational/Amenity space)		
(A-Deductions)		1047.98
PLOT AREA FOR COVERAGE(Net Plot Area)		
(A-Deductions)		1103.51
Plot Area for FAR (Net Plot Area + Road Widening Area)		
(A-Deductions)		1214.15
COVERAGE CHECK		
Permissible Coverage area (50.00 %)		551.76
Proposed Coverage Area (11.85 %)		130.81
Total Prop. Coverage Area (11.85 %)		130.81
Balance coverage area (38.15 %)		420.95
FAR CHECK		
Perm. FAR Area (2.00)		2428.30
Total Perm. FAR area		2428.30
Residential FAR		265.62
Proposed FAR Area		265.62
Total Proposed FAR Area		265.62
Consumed FAR (Factor)		0.22
Balance FAR Area		2162.68
BUILT UP AREA CHECK		
Total Proposed BuiltUp Area		265.62
ARCHITECT (Regd)	DEELIP KUMAR	
ENGINEER (Regd)		
SUPERVISOR (Regd)		
OWNER (Regd)	DAVID KANDULNA JOHN KANDULNA	
DEVELOPMENT AUTHORITY LOCAL BODY		

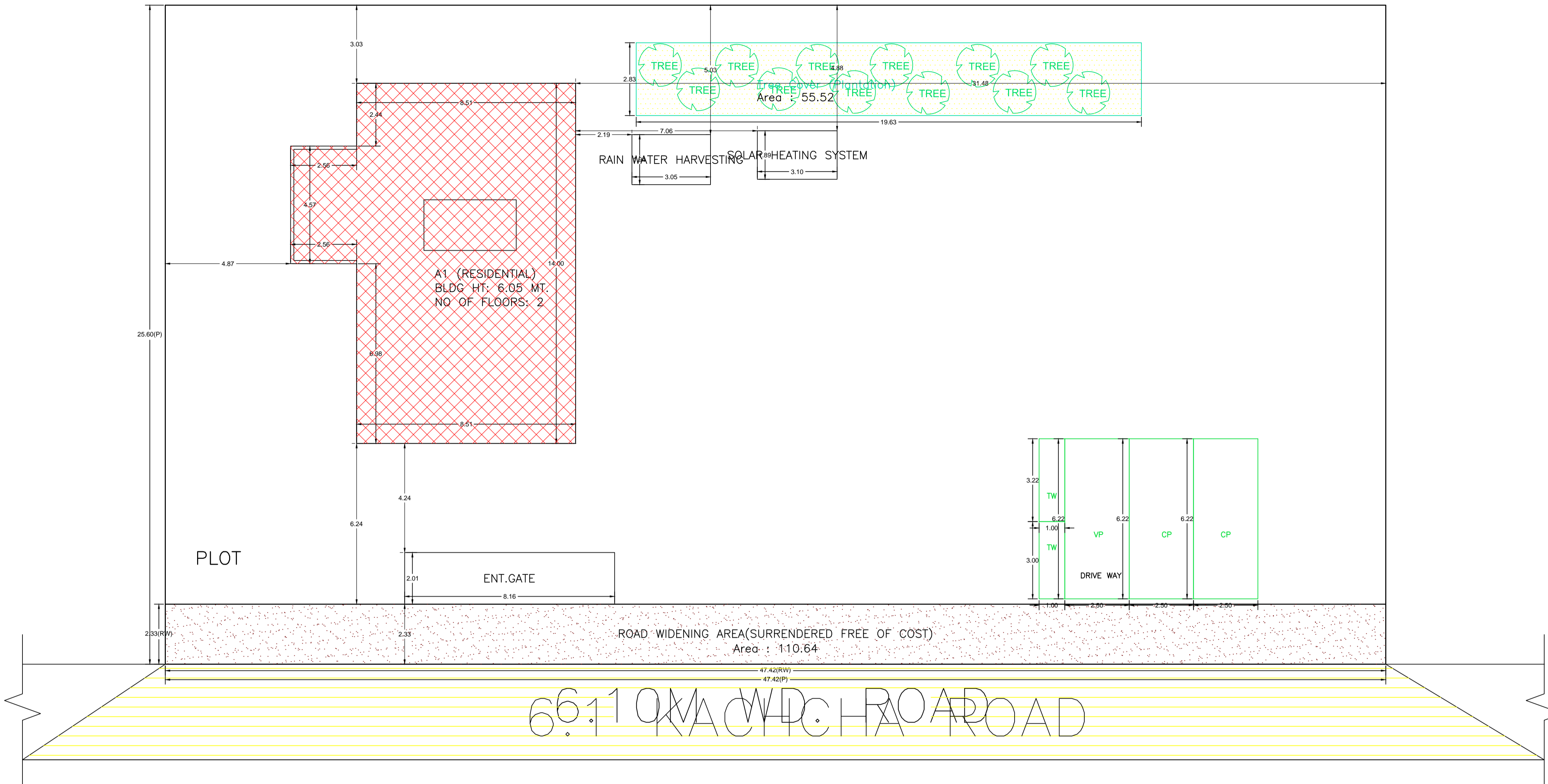

SITE PLAN

FAR & Tenement Details (Table 4c-1)

Building	No. of Same Bldg	Total Built Up Area (Sq.mt.)	Proposed FAR Area (Sq.mt.)	Total FAR Area (Sq.mt.)	Total Consumed Additional FAR Area (Sq.mt.)	Tnmt (No.)
A1 (RESIDENTIAL)	1	265.62	265.62	265.62	265.62	02
Grand Total	1	265.62	265.62	265.62	265.62	02

COLOR INDEX

PLOT BOUNDARY	Black
ABUTTING ROAD	Green
PROPOSED CONSTRUCTION	Red
COMMON PLOT	Yellow
ROAD WIDENING AREA	Blue
EXISTING (To be retained)	Orange
EXISTING (To be demolished)	Light Blue

Required Parking(Table 7a)

Building Name	Type	SubUse	Area (Sq.mt.)	Units		Car		Visitors Car		TwoWheeler		
				Reqd.	Prop.	Reqd./Unit	Prop.	Reqd./Unit	Prop.	Reqd./Unit	Prop.	
A1 (RESIDENTIAL)	Residential	Bungalow/ Dwelling / Non Apartment	> 0	1	2.00	1	2	-	-	-	-	
			> 0	1	2.00	-	-	1	1	-	-	
Total:			-	-	-	2	2	-	1	1	0	2

Parking Check (Table 7b)

Vehicle Type	Reqd.		Prop.	
	No.	Area	No.	Area
Car	-	-	2	31.08
Total Car	2	25.00	2	31.08
Visitor's Car Parking	-	-	1	15.54
Total Visitor Parking	1	12.50	1	15.54
TwoWheeler	-	-	2	6.22
Total TwoWheeler	-	-	2	6.22
Total		37.50		59.06

Buildingwise Floor FAR Details

Floor Name	Building Name		Total	
	Proposed Built Up Area (Sq.mt.)	Proposed FAR Area (Sq.mt.)	Total Proposed Built Up Area (Sq.mt.)	Total FAR Area (Sq.mt.)
Ground Floor	130.81	130.81	130.81	130.81
First Floor	134.81	134.81	134.81	134.81
Terrace Floor	0.00	0.00	0.00	0.00
Total :	265.62	265.62	265.62	265.62

LTP NAME AND SIGNATURE DEELIP KUMAR SINPC/DFTMIN/0003/2023	STRUCTURAL ENG'S NAME AND SIGNATURE	BUILDER NAME AND SIGNATURE	DIGITAL SIGNATURE
--	-------------------------------------	----------------------------	-------------------

Proposal Basic Information

Proposal File No.	SINPC/BI/0518/W04/2024
Owner Name	DAVID KANDULNA JOHN KANDULNA
Khata No	73
Plot No	1393
Village Name	Saldaga
Use	Residential
SubUse	Bungalow/ Dwelling / Non Apartment

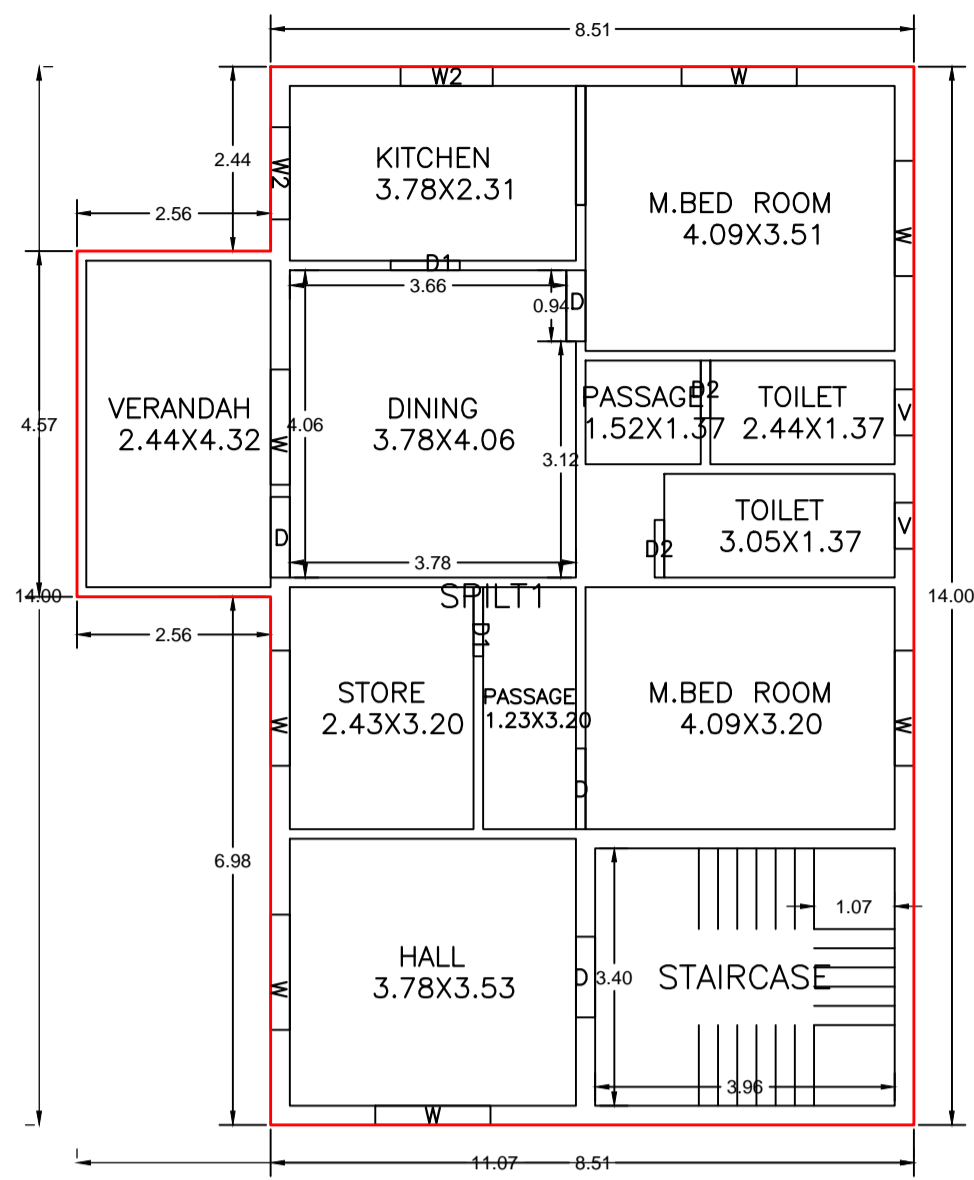

GROUND FLOOR PLAN (Proposed) (SCALE 1:100)

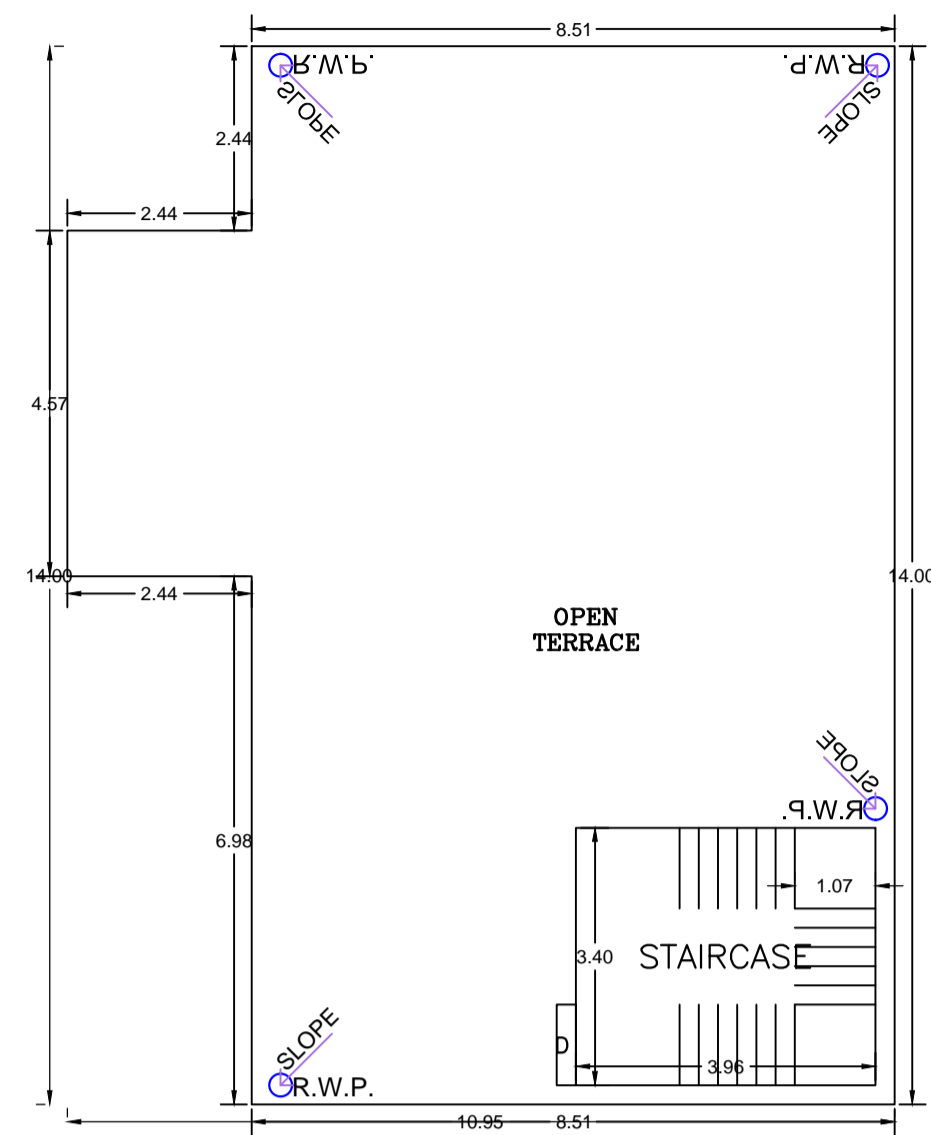

TERRACE FLOOR PLAN (SCALE 1:100)

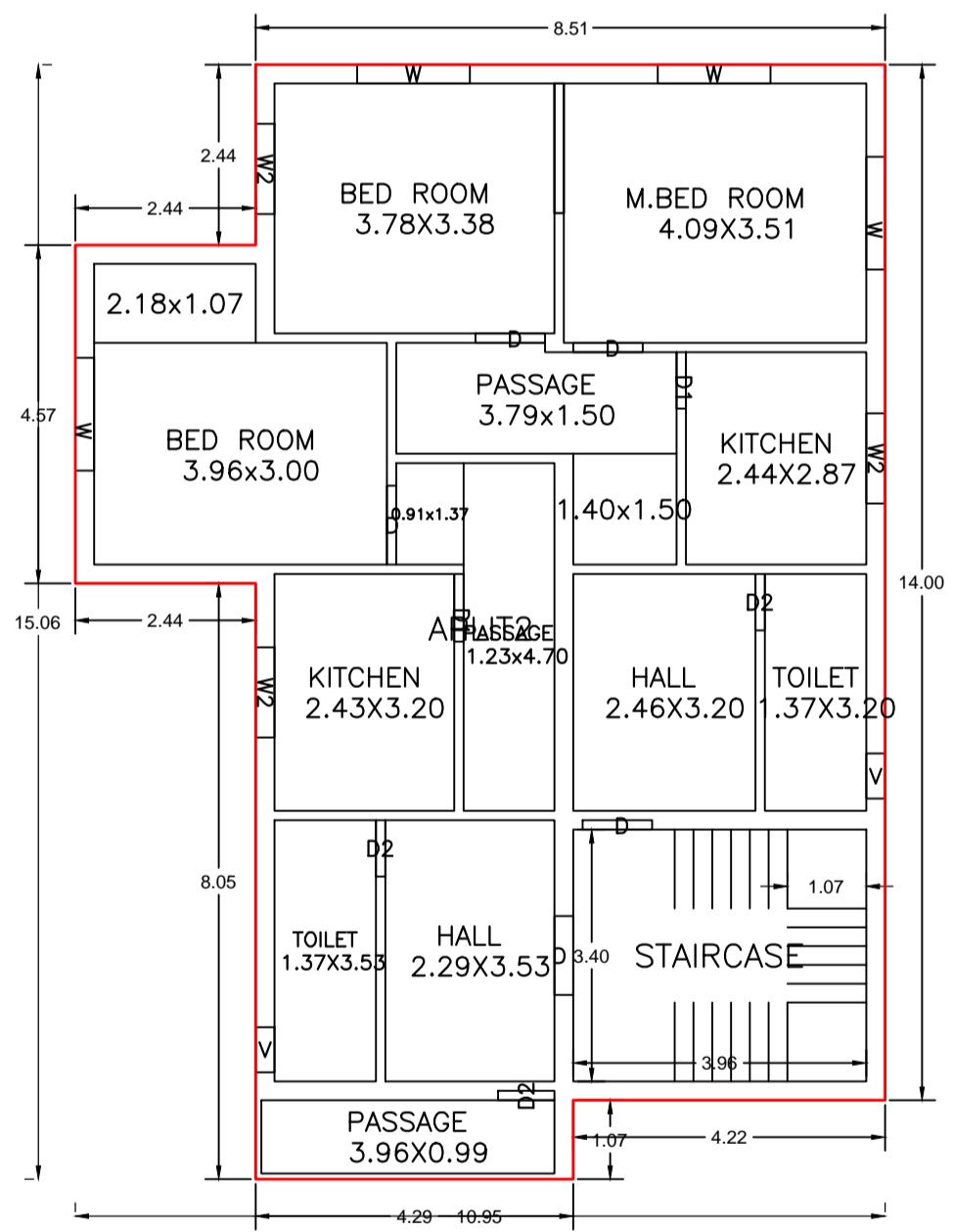

FIRST FLOOR PLAN (Proposed) (SCALE 1:100)



SECTION ON (SCALE 1:100)

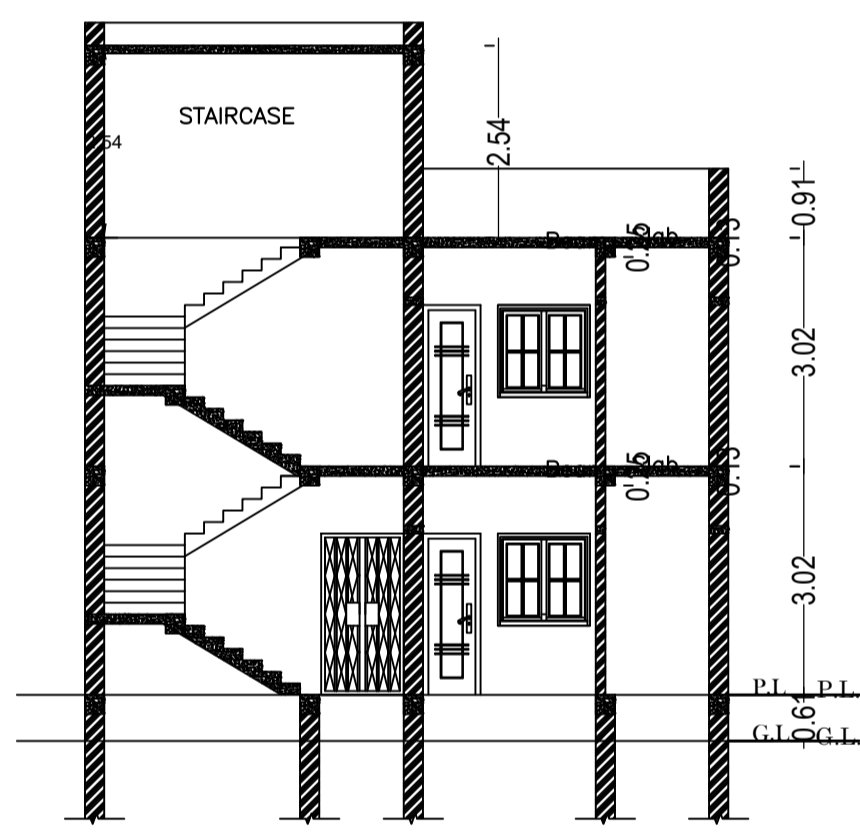

SECTION ON (SCALE 1:100)

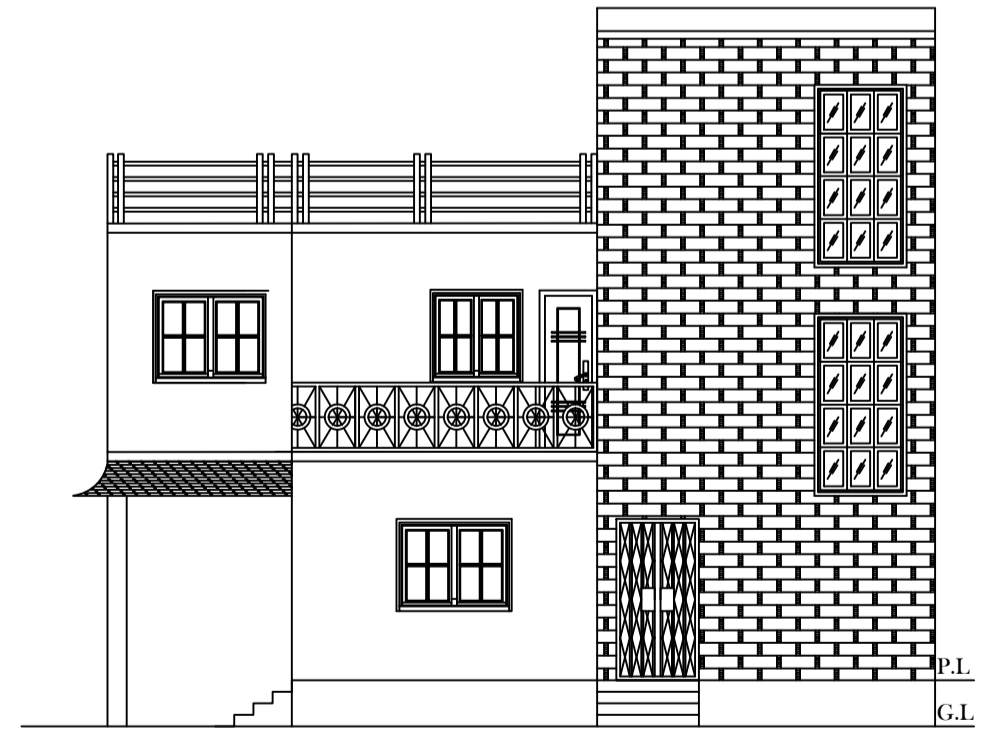

RIGHT SIDE ELEVATION (SCALE 1:100)

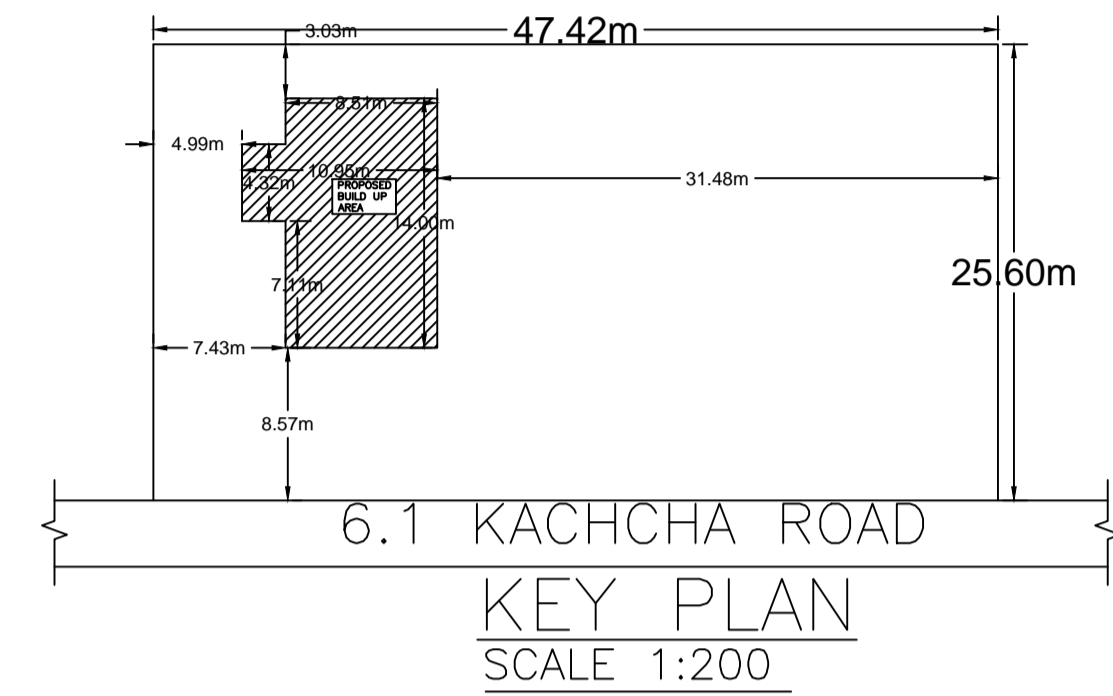

KEY PLAN (SCALE 1:200)

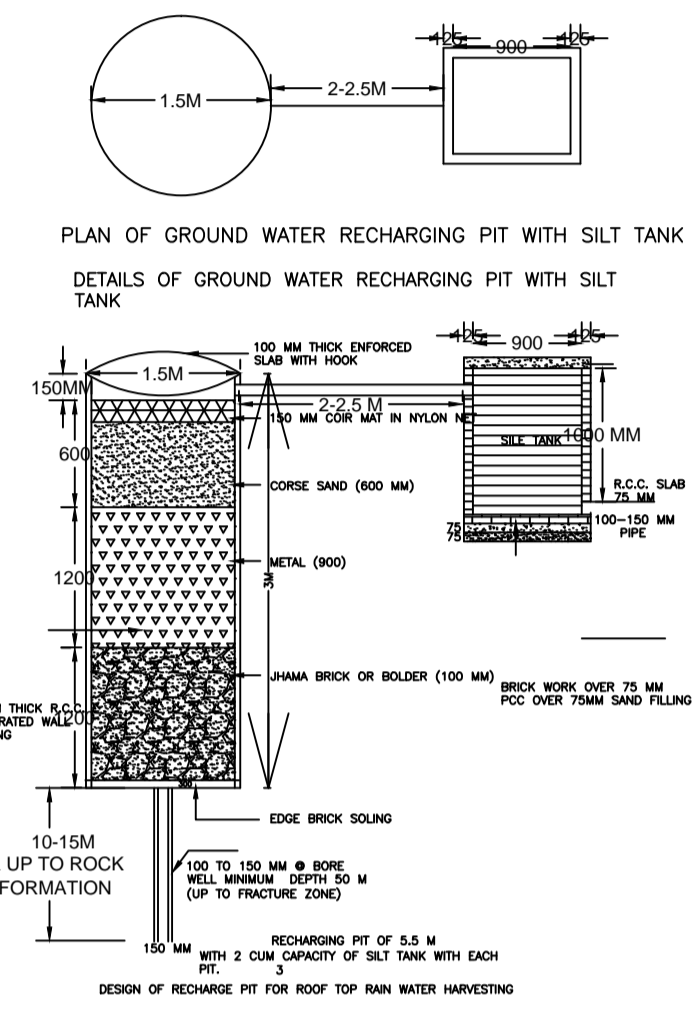

PLAN OF GROUND WATER RECHARGING PIT WITH SILT TANK
DETAILS OF GROUND WATER RECHARGING PIT WITH SILT TANK

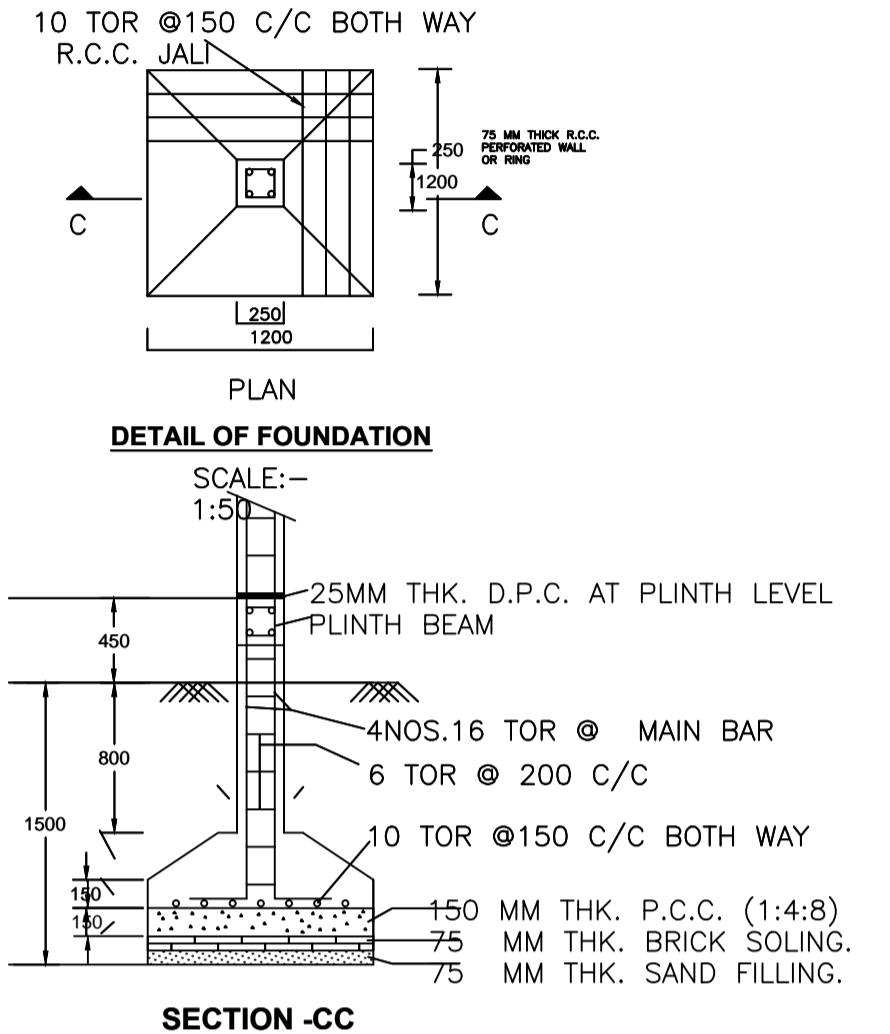

SECTION -CC (SCALE: 1:50)

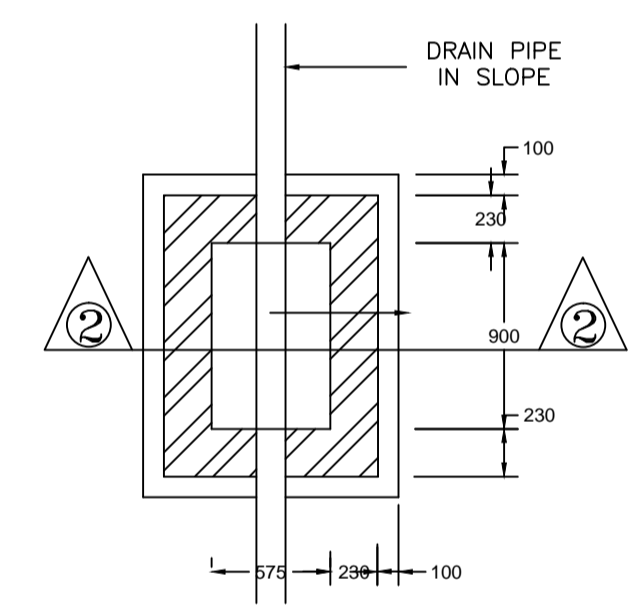

PLAN I.C. DETAILS

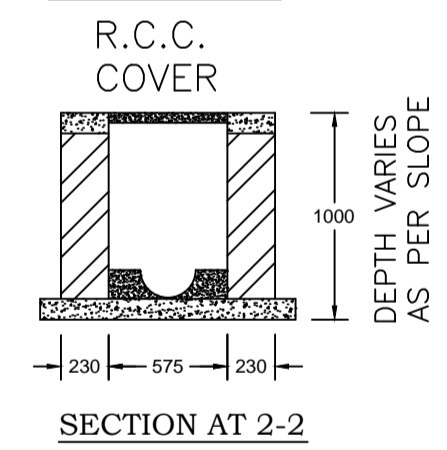

SECTION AT 2-2

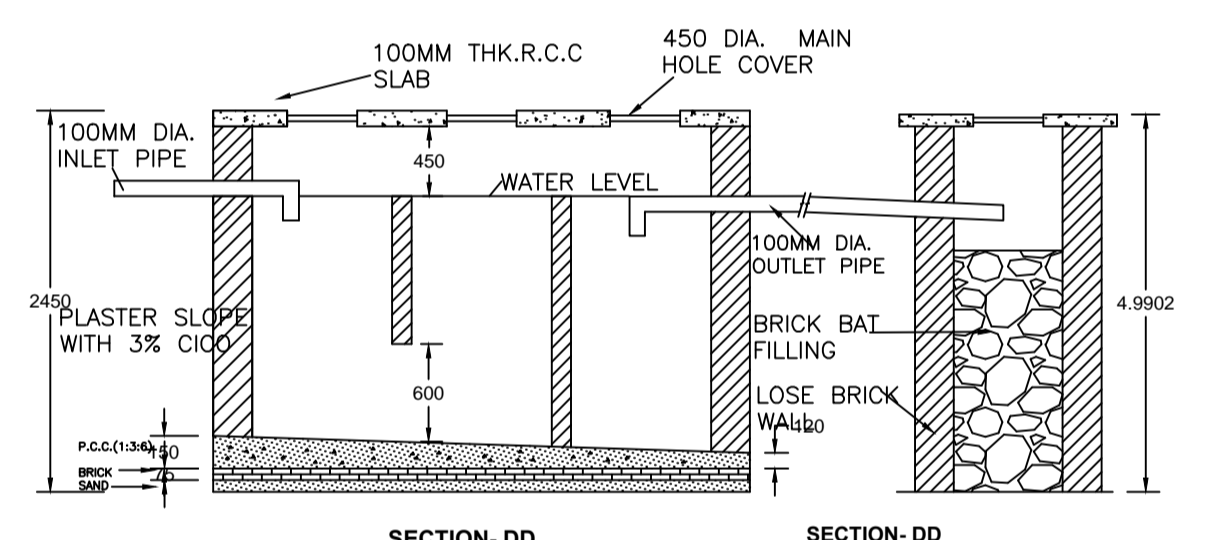

SECTION -DD (SCALE - 1:50)

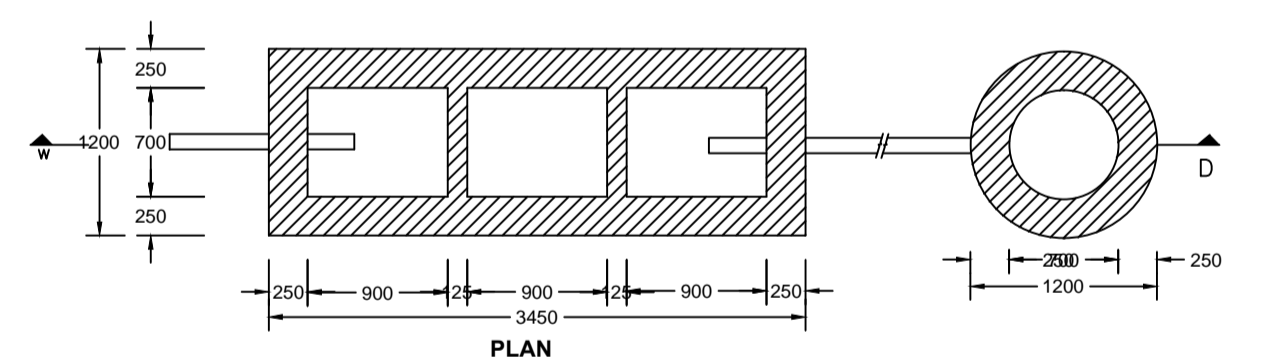

DETAIL OF SEPTIC TANK & SOAKPIT. (SCALE - 1:50)

Building :A1 (RESIDENTIAL)

Floor Name	Total Built Up Area (Sq.mt.)	Proposed FAR Area (Sq.mt.)	Total FAR Area (Sq.mt.)	Total Consumed Additional FAR Area (Sq.mt.)	Tnmt (No.)
Ground Floor	130.81	130.81	130.81	130.81	01
First Floor	134.81	134.81	134.81	134.81	01
Terrace Floor	0.00	0.00	0.00	0.00	00
Total:	265.62	265.62	265.62	265.62	02
Total Number of Same Buildings	1				
Total:	265.62	265.62	265.62	265.62	02

SCHEDULE OF DOOR:

BUILDING NAME	NAME	LENGTH	HEIGHT	NOS
A1 (RESIDENTIAL)	D1	0.76	2.10	01
A1 (RESIDENTIAL)	D2	0.76	2.10	05
A1 (RESIDENTIAL)	D1	0.91	2.10	03
A1 (RESIDENTIAL)	D	0.94	2.10	03
A1 (RESIDENTIAL)	D	1.07	2.10	05

SCHEDULE OF WINDOW/VENTILATION:

BUILDING NAME	NAME	LENGTH	HEIGHT	NOS
A1 (RESIDENTIAL)	V	0.61	1.20	04
A1 (RESIDENTIAL)	W2	1.22	1.20	05
A1 (RESIDENTIAL)	W	1.52	1.20	11

UnitBUA Table for Building :A1 (RESIDENTIAL)

FLOOR	Name	UnitBUA Type	UnitBUA Area	Carpet Area	No. of Rooms	No. of Tenement
GROUND FLOOR PLAN	SPLIT1	FLAT	104.12	103.92	11	1
FIRST FLOOR PLAN	APLIT2	FLAT	107.25	107.03	12	1
Total:	-	-	211.37	210.95	23	2

LTP NAME AND SIGNATURE	STRUCTURAL ENG'S NAME AND SIGNATURE	BUILDER NAME AND SIGNATURE	DIGITAL SIGNATURE
DEELIP KUMAR SINPC/DFTMN/0003/2023			

Proposal Basic Information

Proposal File No.	SINPC/BP/0518/W04/2024
Owner Name	DAVID KANDULNA JOHN KANDULNA
Khata No	73
Plot No	1393
Village Name	Saldega
Use	Residential
SubUse	Bungalow/ Dwelling / Non Apartment

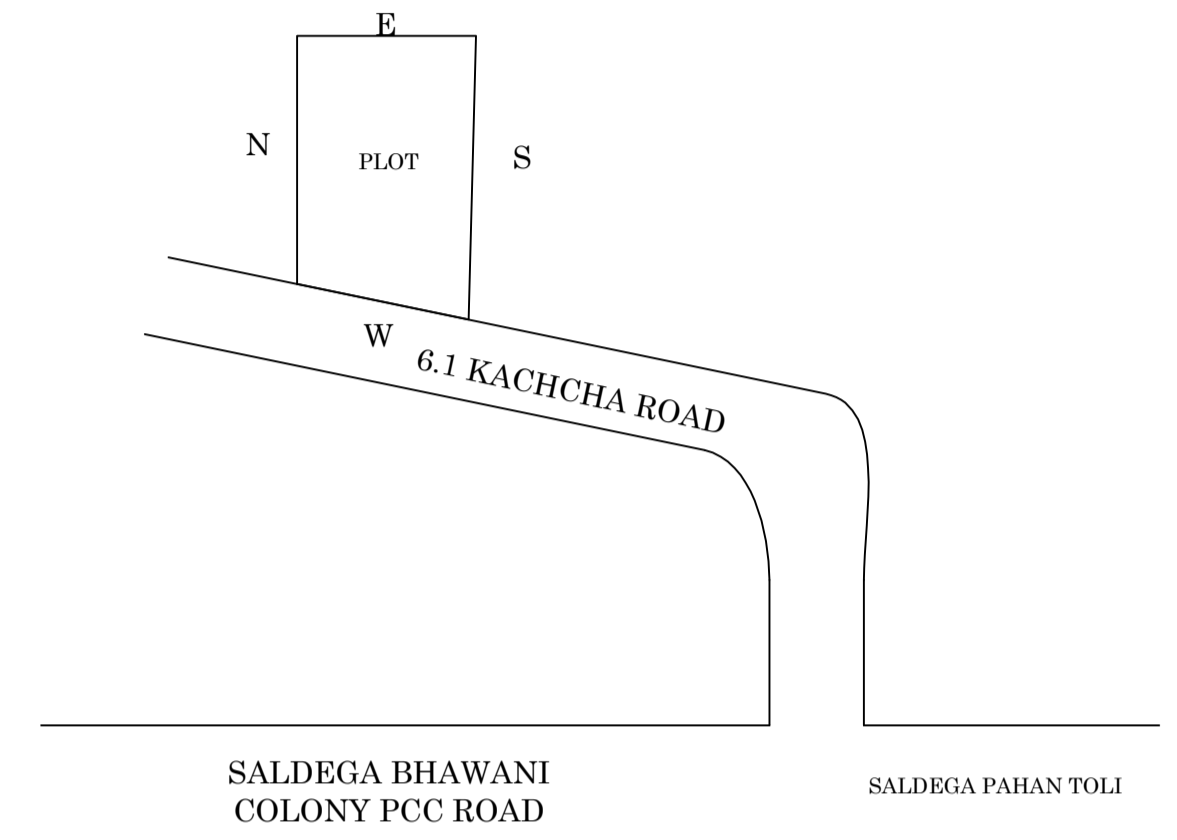

LOCATION PLAN
NOT IN SCALE

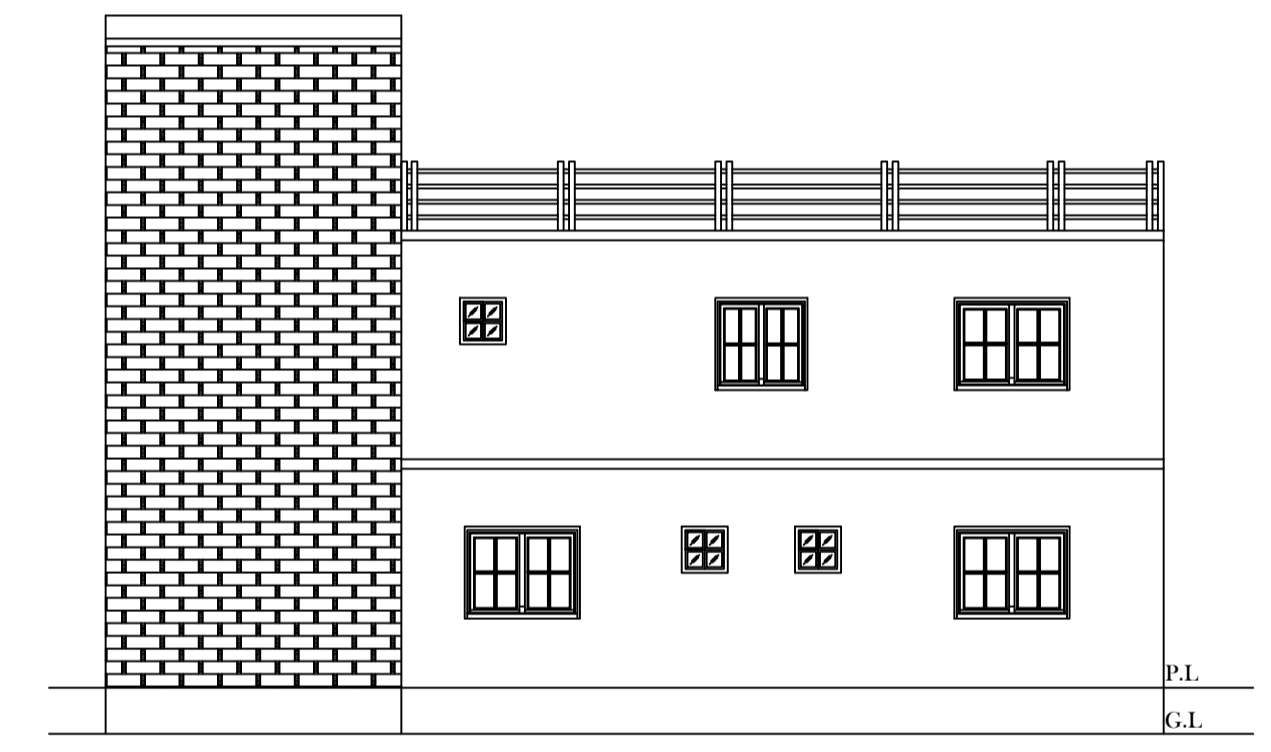

FRONT ELEVATION
SCALE 1:100

LTP NAME AND SIGNATURE	STRUCTURAL ENG'S NAME AND SIGNATURE	BUILDER NAME AND SIGNATURE	DIGITAL SIGNATURE
DEELIP KUMAR SINPC/DFTMN/0003/2023			