

SITE PLAN

FAR & Tenement Details (Table 4c-1)

Building	No. of Same Bldg	Total Built Up Area (Sq.mt.)	Proposed FAR Area (Sq.mt.) Resi.	Total FAR Area (Sq.mt.)	Total Consumed Additional FAR Area (Sq.mt.)	Tnmt (No.)
A1 (RESIDENTIAL)	1	243.87	243.87	243.87	243.87	02
Grand Total :	1	243.87	243.87	243.87	243.87	02

Proposal Basic Information

Proposal File No.	SINPC/BP/0500/W06/2024
Owner Name	INDU MINZ
Khata No	96
Plot No	2239
Village Name	Khijri
Use	Residential
SubUse	Bungalow/ Dwelling / Non Apartment

Required Parking (Table 7a)

Building Name	Type	SubUse	Area (Sq.mt.)	Units		Car		Visitors Car		TwoWheeler	
				Reqd.	Prop.	Reqd./Unit	Prop.	Reqd./Unit	Prop.	Reqd./Unit	Prop.
A1 (RESIDENTIAL)	Residential	Bungalow/ Dwelling / Non Apartment	> 0	1	2.00	1	2	-	-	-	-
			> 0	1	2.00	-	-	1	1	-	-
Total :			-	-	-	-	2	2	-	1	1

Parking Check (Table 7b)

Vehicle Type	Reqd.		Prop.	
	No.	Area	No.	Area
Car	-	-	2	26.42
Total Car	2	25.00	2	26.42
Visitor's Car Parking	-	-	1	13.21
Total Visitor Parking	1	12.50	1	13.21
TwoWheeler	-	-	2	7.39
Total TwoWheeler	-	-	2	7.39
Total		37.50		54.41

AREA STATEMENT SIMDEGA NAGAR PANCHAYAT	VERSION NO: 1.0.70
PROJECT DETAIL:	VERSION DATE: 16/10/2020
Region: JHARKHAND URBAN LOCAL BODIES	Plot Use: Residential
District: SIMDEGA	Plot SubUse: Bungalow/ Dwelling / Non Apartment
Authority: SIMDEGA NAGAR PANCHAYAT	PlotNearby/ReligiousStructure: NA
Inward No: SINPC/BP/0500/W06/2024	Plot/SubPlot No: 2239
Application Type: General Proposal	North: -
Project Type: Building Permission	South: -
Nature of Development: New	East: -
Location of Development Area: Old Area	West: -
AREA DETAILS:	SQ.MT.
AREA OF PLOT (Minimum)	(A) 280.59
Deduction for NetPlot Area	
Surrender Free of Cost	17.04
Total	17.04
NET AREA OF PLOT(Gross Plot Area - Deduction from Gross Plot area)	(A-Deductions) 263.55
Deduction for Balance Plot Area(from Gross Plot Area)	
Surrender Free of Cost	17.04
Common Plot	16.97
Total	34.01
BALANCE AREA OF PLOT(Net Plot Area - Recreational/Amenity space)	(A-Deductions) 246.58
PLOT AREA FOR COVERAGE(Net Plot Area)	(A-Deductions) 263.55
Plot Area for FAR (Net Plot Area + RoadWidening Area)	(A-Deductions) 280.59
COVERAGE CHECK	
Permissible Coverage area ( 60.00 % )	158.13
Proposed Coverage Area ( 43.65 % )	115.03
Total Prop. Coverage Area ( 43.65 % )	115.03
Balance coverage area ( 16.35 % )	43.10
FAR CHECK	
Perm. FAR Area ( 1.500 )	420.89
Total Perm. FAR area	420.89
Residential FAR	243.87
Proposed FAR Area	243.87
Total Proposed FAR Area	243.87
Consumed FAR (Factor)	0.87
Balance FAR Area	177.02
BUILT UP AREA CHECK	
Total Proposed BuiltUp Area	243.87
ARCHITECT (Regd)	DEELIP KUMAR
ENGINEER (Regd)	
SUPERVISOR (Regd)	
OWNER (Regd)	INDU MINZ
DEVELOPMENT AUTHORITY	LOCAL BODY

COLOR INDEX	
PLOT BOUNDARY	Black
ABUTTING ROAD	Green
PROPOSED CONSTRUCTION	Red
COMMON PLOT	Yellow
ROAD WIDENING AREA	Orange
EXISTING (To be retained)	Blue
EXISTING (To be demolished)	Light Blue

Buildingwise Floor FAR Details

Floor Name	Building Name		Total	
	Proposed Built Up Area (Sq.mt.)	Proposed FAR Area (Sq.mt.)	Total Proposed Built Up Area (Sq.mt.)	Total FAR Area (Sq.mt.)
Ground Floor	115.03	115.03	115.03	115.03
First Floor	128.84	128.84	128.84	128.84
Terrace Floor	0.00	0.00	0.00	0.00
Total	243.87	243.87	243.87	243.87

Building USE/SUBUSE Details

Building Name	Building Use	Building SubUse	Building Structure
A1 (RESIDENTIAL)	Residential	Bungalow/ Dwelling / Non Apartment	Non-Highrise

LTP NAME AND SIGNATURE	STRUCTURAL ENG'S NAME AND SIGNATURE	BUILDER NAME AND SIGNATURE	DIGITAL SIGNATURE
DEELIP KUMAR SINPC/DFTMN/0003/2023			

Proposal Basic Information

Proposal File No.	SINPC/BI/0500/W06/2024
Owner Name	INDU MINU
Khata No	96
Plot No	2239
Village Name	Khijri
Use	Residential
SubUse	Bungalow/ Dwelling / Non Apartment

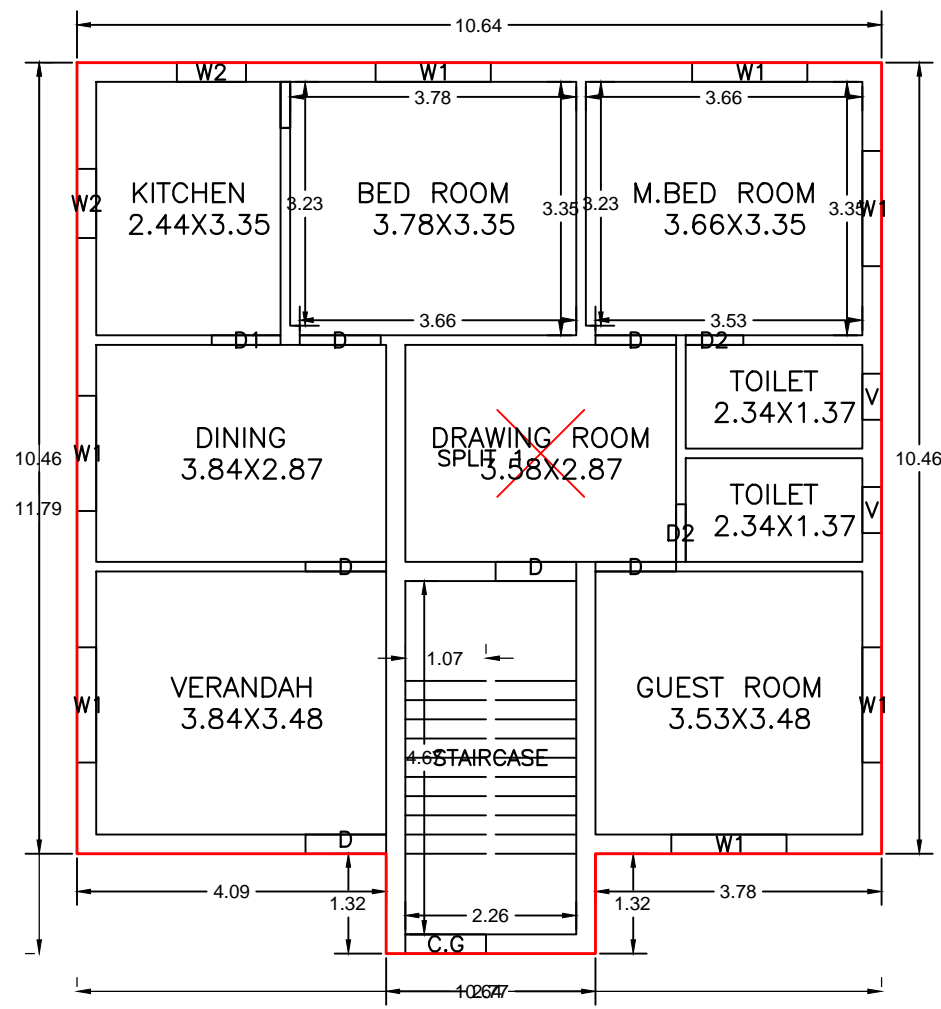

GROUND FLOOR PLAN (Proposed) (SCALE 1:100)

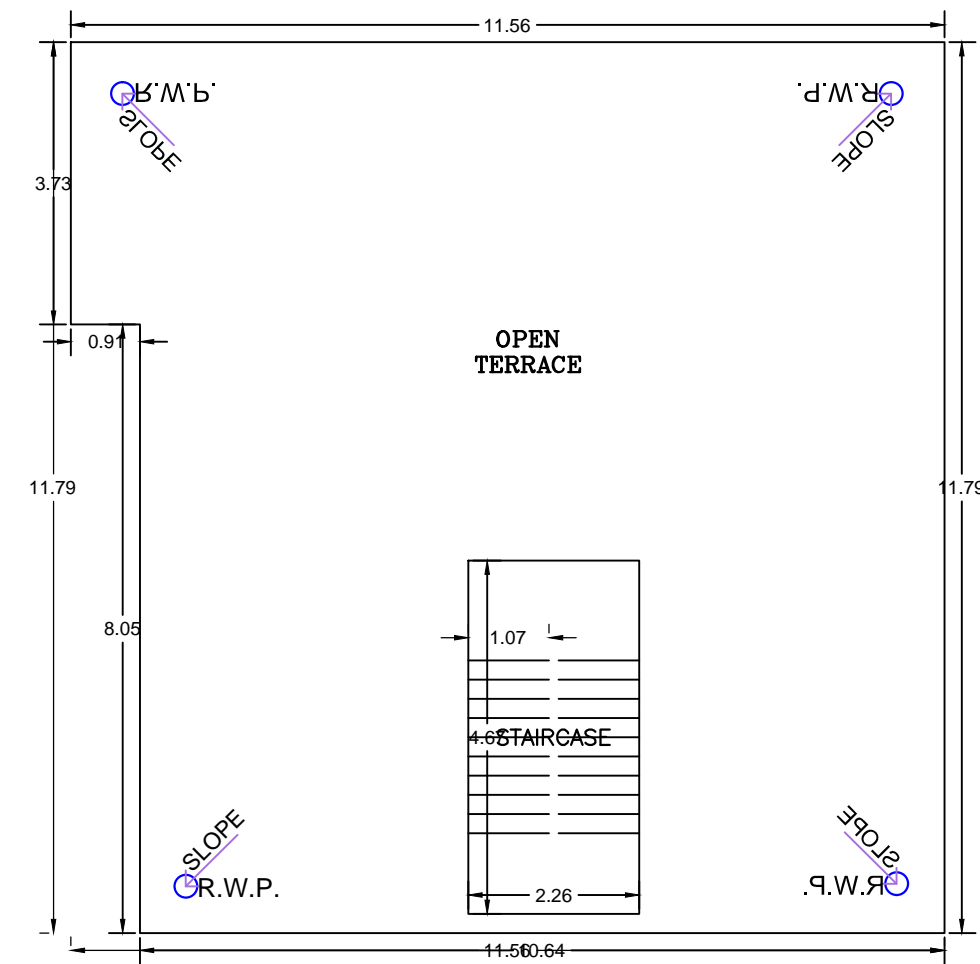

TERRACE FLOOR PLAN (SCALE 1:100)

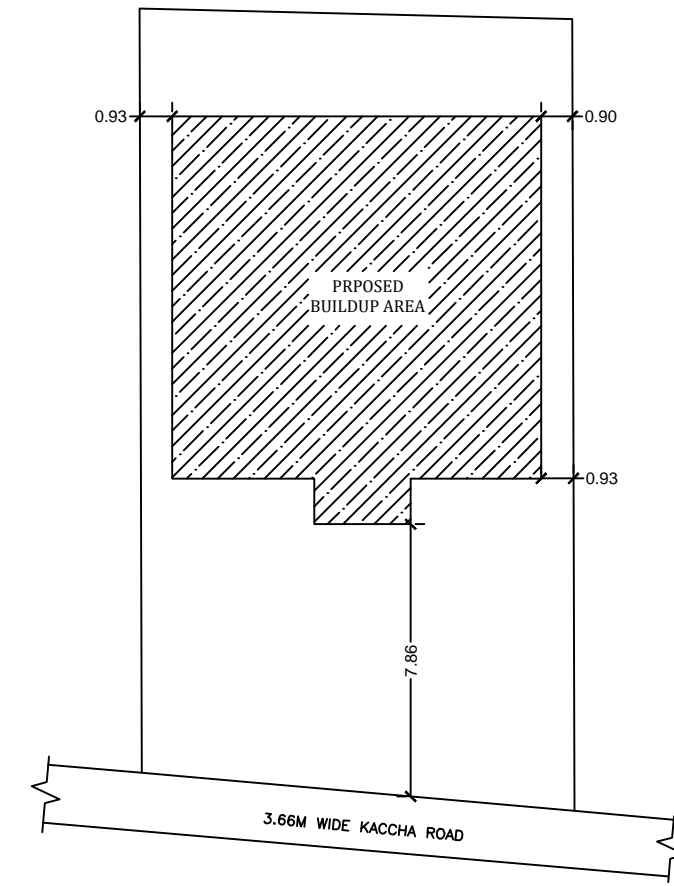

KEY PLAN (SCALE 1:200)

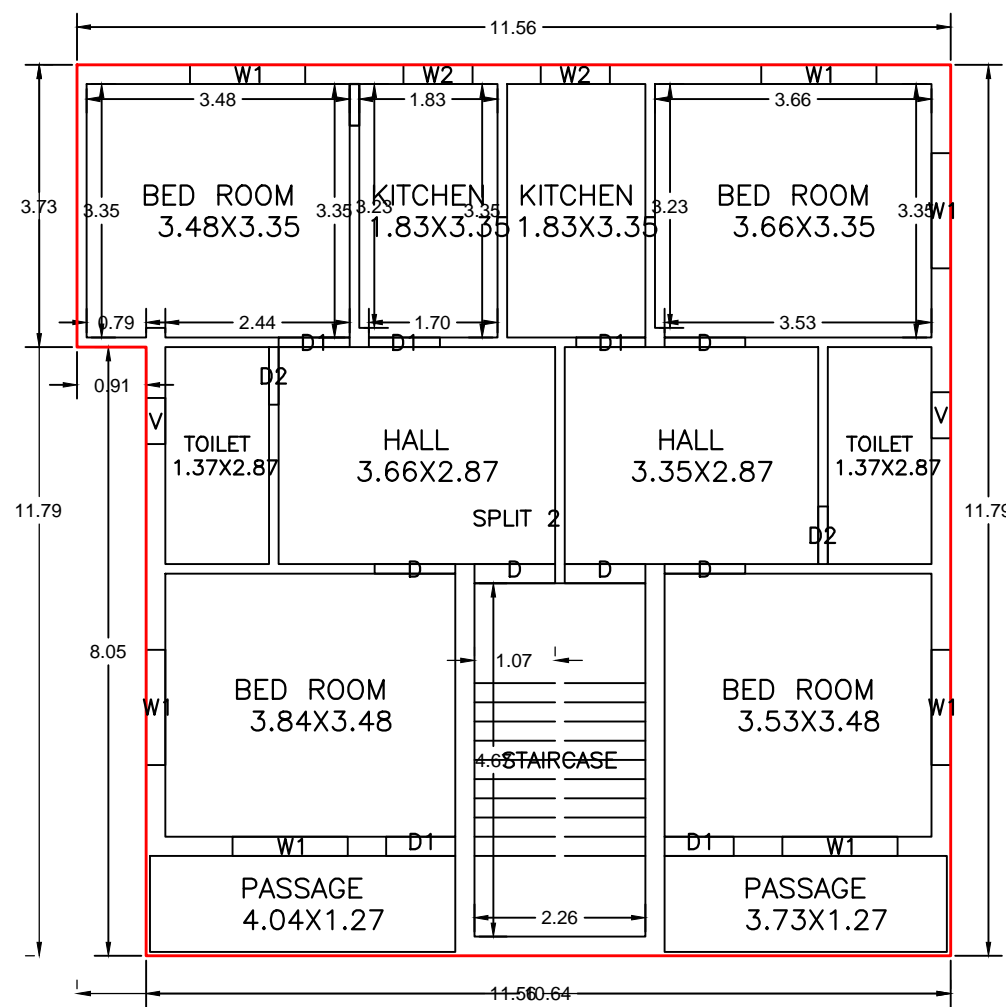

FIRST FLOOR PLAN (Proposed) (SCALE 1:100)

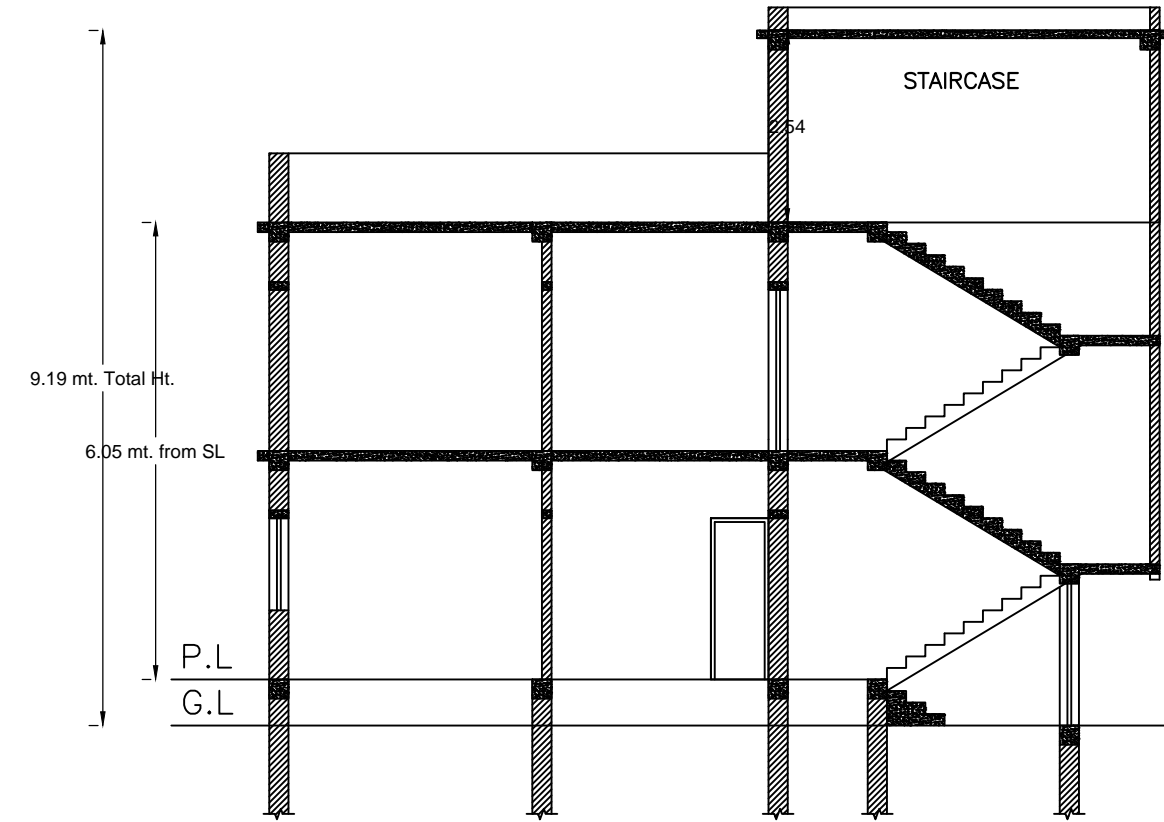

SECTION ON (SCALE 1:100)

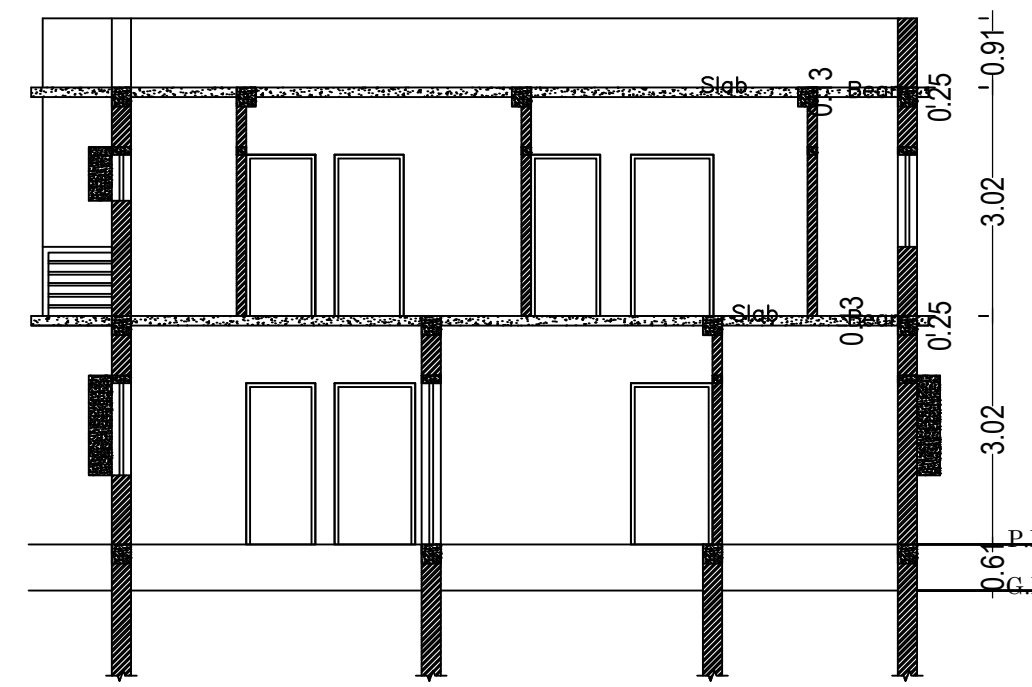

SECTION ON (SCALE 1:100)

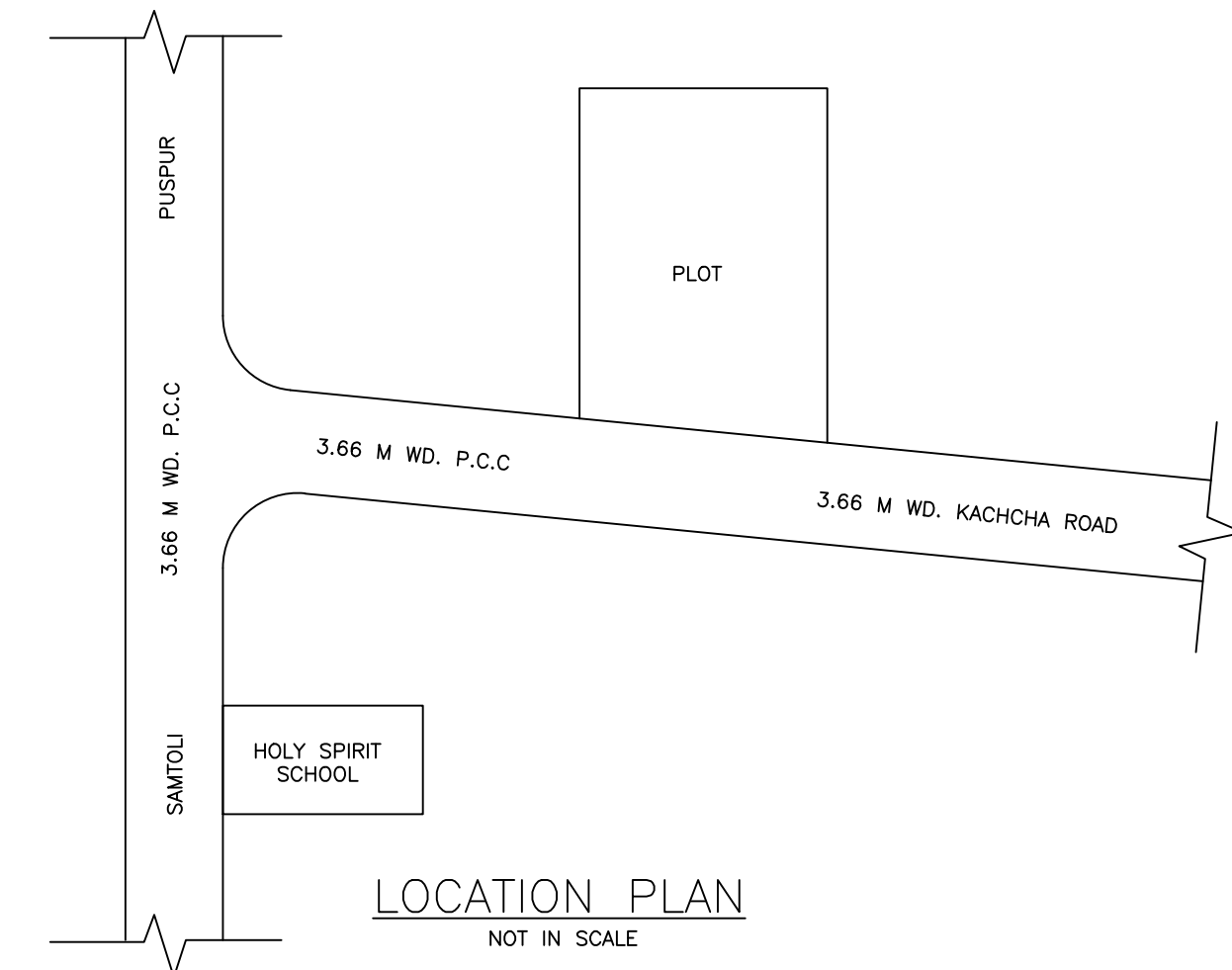

LOCATION PLAN (NOT IN SCALE)

Building :A1 (RESIDENTIAL)

Floor Name	Total Built Up Area (Sq.mt.)	Proposed FAR Area (Sq.mt.)	Total FAR Area (Sq.mt.)	Total Consumed Additional FAR Area (Sq.mt.)	Tnmt (No.)
Ground Floor	115.03	115.03	115.03	115.03	01
First Floor	128.84	128.84	128.84	128.84	01
Terrace Floor	0.00	0.00	0.00	0.00	00
Total:	243.87	243.87	243.87	243.87	02
Total Number of Same Buildings	1				
Total:	243.87	243.87	243.87	243.87	02

SCHEDULE OF DOOR:

BUILDING NAME	NAME	LENGTH	HEIGHT	NOS
A1 (RESIDENTIAL)	D2	0.76	2.10	04
A1 (RESIDENTIAL)	D1	0.91	2.10	04
A1 (RESIDENTIAL)	D1	0.94	2.10	02
A1 (RESIDENTIAL)	D	1.07	2.10	11

SCHEDULE OF WINDOW/VENTILATION:

BUILDING NAME	NAME	LENGTH	HEIGHT	NOS
A1 (RESIDENTIAL)	V	0.61	1.20	04
A1 (RESIDENTIAL)	W2	0.91	1.20	04
A1 (RESIDENTIAL)	W1	1.52	1.20	14

UnitBUA Table for Building :A1 (RESIDENTIAL)

FLOOR	Name	UnitBUA Type	UnitBUA Area	Carpet Area	No. of Rooms	No. of Tenement
GROUND FLOOR PLAN	SPLIT 1	FLAT	90.92	90.84	9	1
FIRST FLOOR PLAN	SPLIT 2	FLAT	106.12	106.05	12	1
Total:	-	-	197.04	196.89	21	2

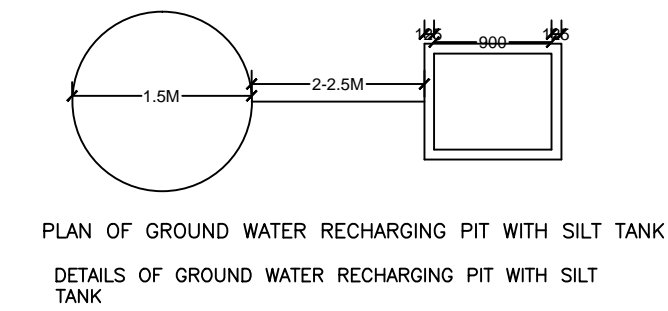

PLAN OF GROUND WATER RECHARGING PIT WITH SILT TANK

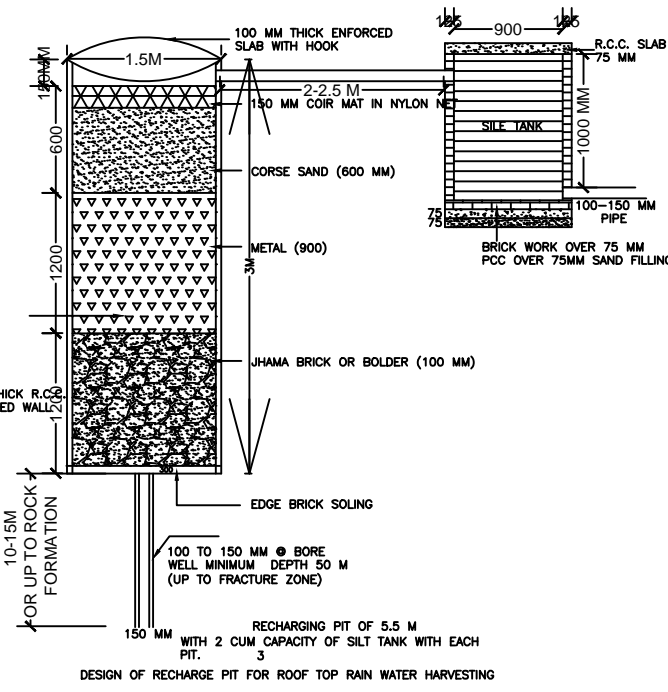

DETAILS OF GROUND WATER RECHARGING PIT WITH SILT TANK

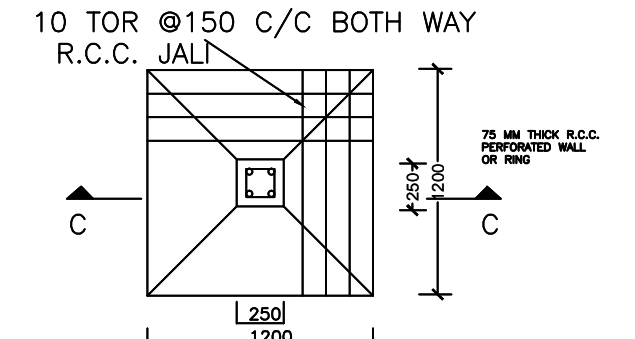

PLAN OF FOUNDATION

SCALE: 1:5

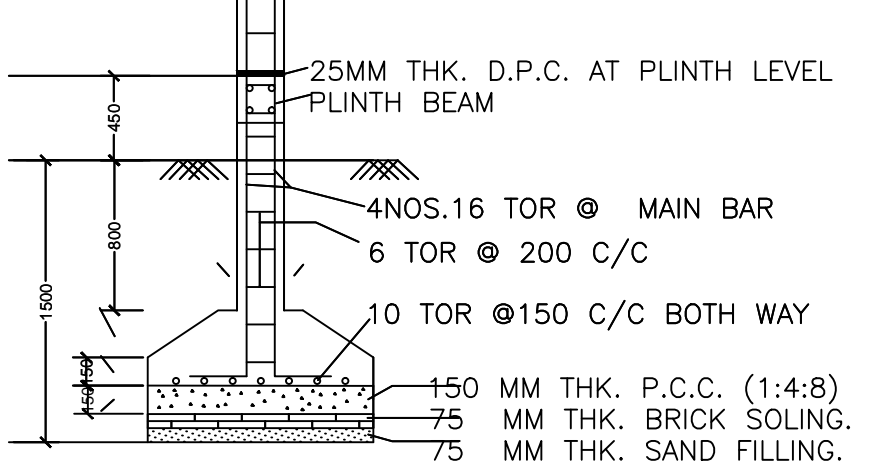

SECTION -CC

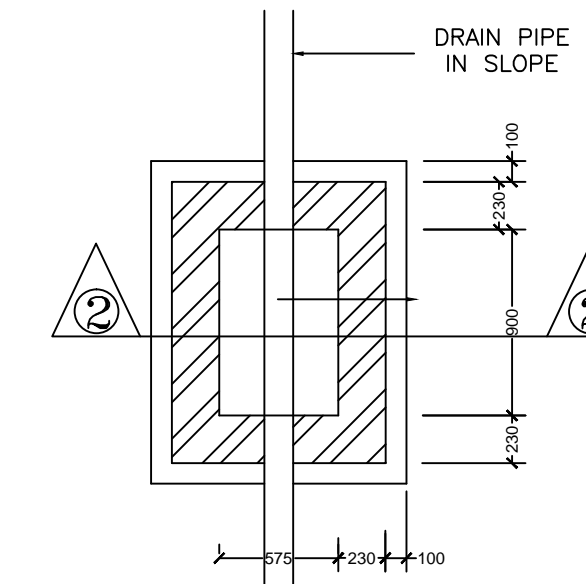

PLAN I.C.DETAILS R.C.C. COVER

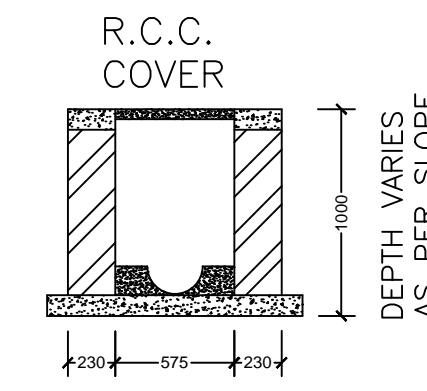

SECTION AT 2-2

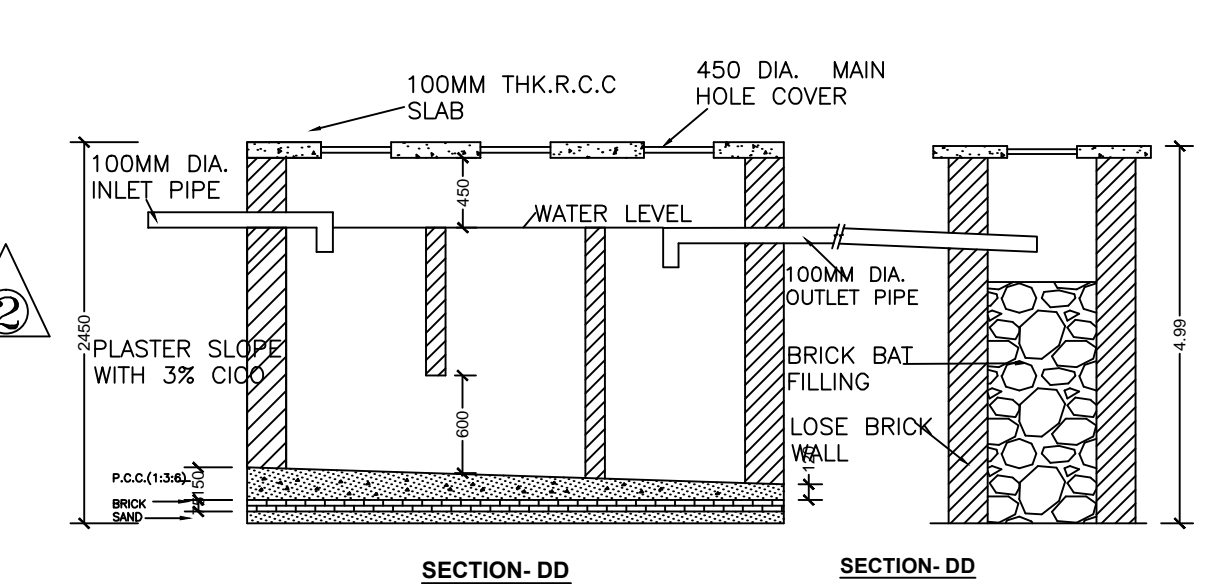

SECTION -DD

SECTION -DD

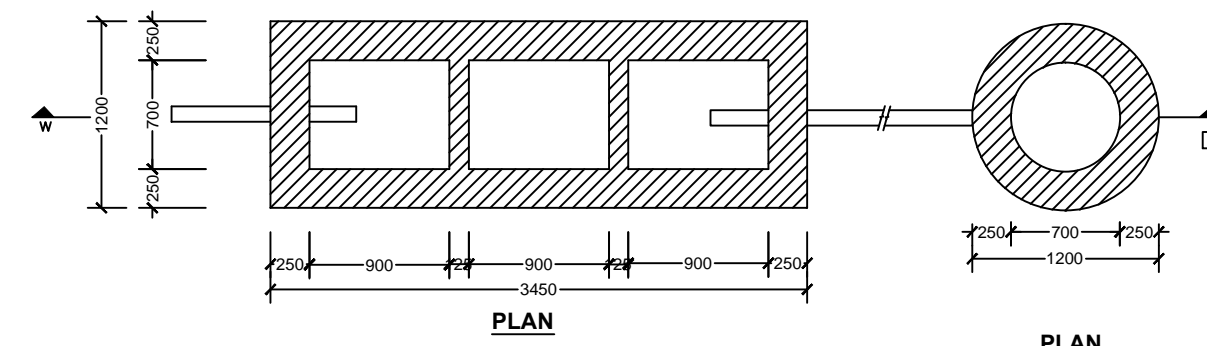

DETAIL OF SEPTIC TANK & SOAKPIT.

PLAN SCALE - 1:50

LTP NAME AND SIGNATURE	STRUCTURAL ENG'S NAME AND SIGNATURE	BUILDER NAME AND SIGNATURE	DIGITAL SIGNATURE
DEELIP KUMAR SINPC/DFTMN/0003/2023			

Proposal Basic Information

Proposal File No.	SINPC/BP/0500/W06/2024
Owner Name	INDU MINU
Khata No	96
Plot No	2239
Village Name	Khijri
Use	Residential
SubUse	Bungalow/ Dwelling / Non Apartment



FRONT ELEVATION  
SCALE 1:100

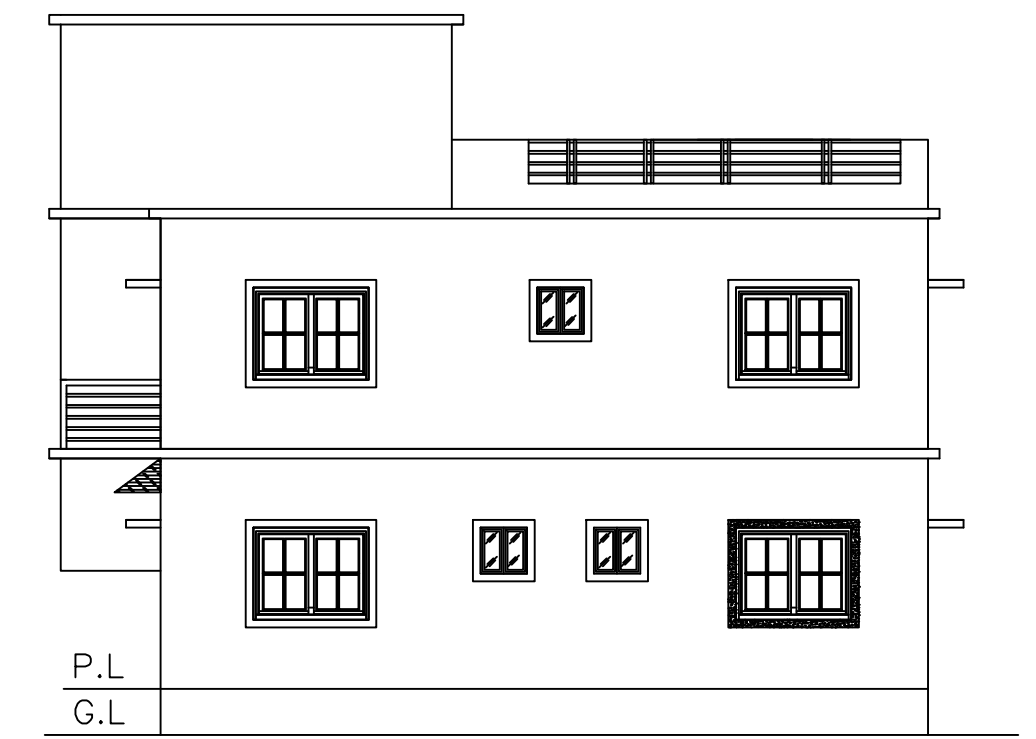

RIGHT SIDE ELEVATION  
SCALE 1:100

LTP NAME AND SIGNATURE	STRUCTURAL ENG'S NAME AND SIGNATURE	BUILDER NAME AND SIGNATURE	DIGITAL SIGNATURE
DEELIP KUMAR SINPC/DFTMN/0003/2023			