

SITE PLAN

FAR & Tenement Details (Table 4c-1)

Building	No. of Same Bldg	Total Built Up Area (Sq.mt.)	Proposed FAR Area (Sq.mt.) Resi.	Total FAR Area (Sq.mt.)	Total Consumed Additional FAR Area (Sq.mt.)	Tnmt (No.)
A1 (RESIDENTIAL)	1	232.90	232.90	232.90	232.90	01
Grand Total :	1	232.90	232.90	232.90	232.90	01

Proposal Basic Information

Proposal File No.	SINPC/BP/0512/W12/2024
Owner Name	PHULMANI XAXA
Khata No	117
Plot No	23
Village Name	Gotra
Use	Residential
SubUse	Bungalow/ Dwelling / Non Apartment

AREA STATEMENT SIMDEGA NAGAR PANCHAYAT	VERSION NO.: 1.0.70
PROJECT DETAIL:	VERSION DATE: 16/10/2020
Region: JHARKHAND URBAN LOCAL BODIES	Plot Use: Residential
District: SIMDEGA	Plot SubUse: Bungalow/ Dwelling / Non Apartment
Authority: SIMDEGA NAGAR PANCHAYAT	PlotNearbyReligiousStructure: NA
Inward No: SINPC/BP/0512/W12/2024	PlotSubPlot No: 23
Application Type: General Proposal	North: -
Project Type: Building Permission	South: -
Nature of Development: New	East: -
Location of Development Area: Old Area	West: -
AREA DETAILS:	SQ.MT.
AREA OF PLOT (Minimum)	(A) 204.39
Deduction for NetPlot Area	
Surrender Free of Cost	10.27
Total	10.27
NET AREA OF PLOT(Gross Plot Area - Deduction from Gross Plot area)	(A-Deductions) 194.11
Deduction for Balance Plot Area(from Gross Plot Area)	
Surrender Free of Cost	10.27
Common Plot	10.50
Total	20.78
BALANCE AREA OF PLOT(Net Plot Area - Recreational/Amenity space)	(A-Deductions) 183.61
PLOT AREA FOR COVERAGE(Net Plot Area)	(A-Deductions) 194.11
Plot Area for FAR (Net Plot Area + RoadWidening Area)	(A-Deductions) 204.39
COVERAGE CHECK	
Permissible Coverage area (70.00 %)	135.88
Proposed Coverage Area (59.99 %)	116.45
Total Prop. Coverage Area (59.99 %)	116.45
Balance coverage area (10.01 %)	19.43
FAR CHECK	
Perm. FAR Area (1.500)	306.58
Total Perm. FAR area	306.58
Residential FAR	232.89
Proposed FAR Area	232.89
Total Proposed FAR Area	232.89
Consumed FAR (Factor)	1.14
Balance FAR Area	73.69
BUILT UP AREA CHECK	
Total Proposed BuiltUp Area	232.90
ARCHITECT (Regd)	DEELIP KUMAR
ENGINEER (Regd)	
SUPERVISOR (Regd)	
OWNER (Regd)	PHULMANI XAXA
DEVELOPMENT AUTHORITY	LOCAL BODY

COLOR INDEX	
PLOT BOUNDARY	Black
ABUTTING ROAD	Green
PROPOSED CONSTRUCTION	Red
COMMON PLOT	Yellow
ROAD WIDENING AREA	Blue
EXISTING (To be retained)	Blue
EXISTING (To be demolished)	Yellow

Buildingwise Floor FAR Details

Floor Name	Building Name		Total	
	Proposed Built Up Area (Sq.mt.)	Proposed FAR Area (Sq.mt.)	Total Proposed Built Up Area (Sq.mt.)	Total FAR Area (Sq.mt.)
Ground Floor	116.45	116.45	116.45	116.45
First Floor	116.45	116.45	116.45	116.45
Terrace Floor	0.00	0.00	0.00	0.00
Total	232.90	232.90	232.90	232.90

Building USE/SUBUSE Details

Building Name	Building Use	Building SubUse	Building Structure
A1 (RESIDENTIAL)	Residential	Bungalow/ Dwelling / Non Apartment	Non-Highrise

LTP NAME AND SIGNATURE	STRUCTURAL ENG'S NAME AND SIGNATURE	BUILDER NAME AND SIGNATURE	DIGITAL SIGNATURE
DEELIP KUMAR SINPC/DFTMN/0003/2023			

Proposal Basic Information

Proposal File No.	SINPC/BI/0512/W12/2024
Owner Name	PHULMANI XAXA
Khata No	117
Plot No	23
Village Name	Gotra
Use	Residential
SubUse	Bungalow/ Dwelling / Non Apartment

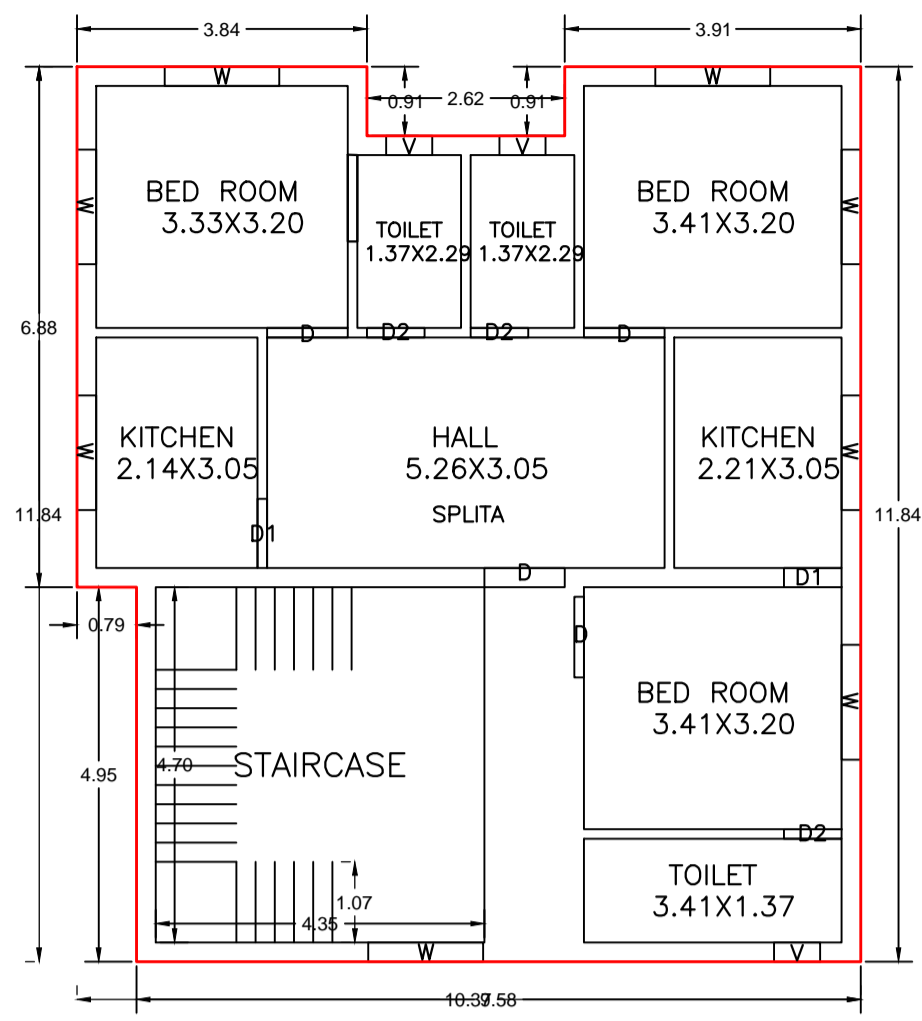

GROUND FLOOR PLAN (Proposed) SCALE 1:100

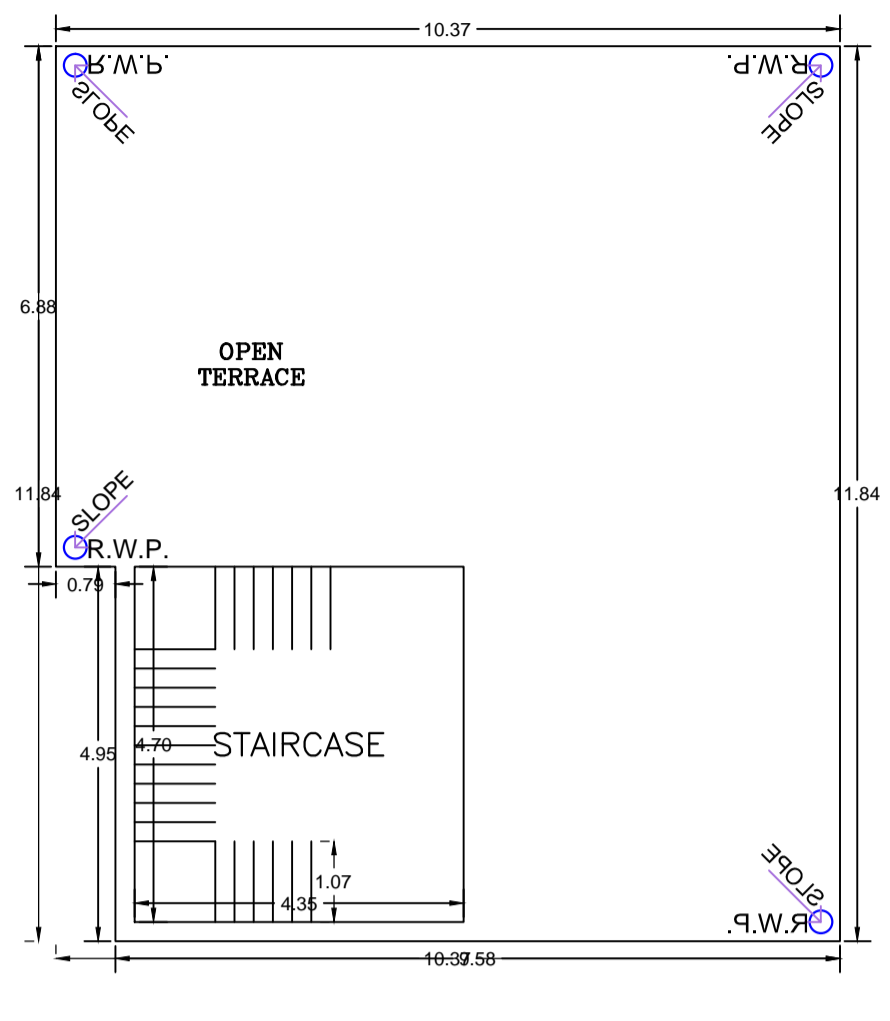

TERRACE FLOOR PLAN (SCALE 1:100)

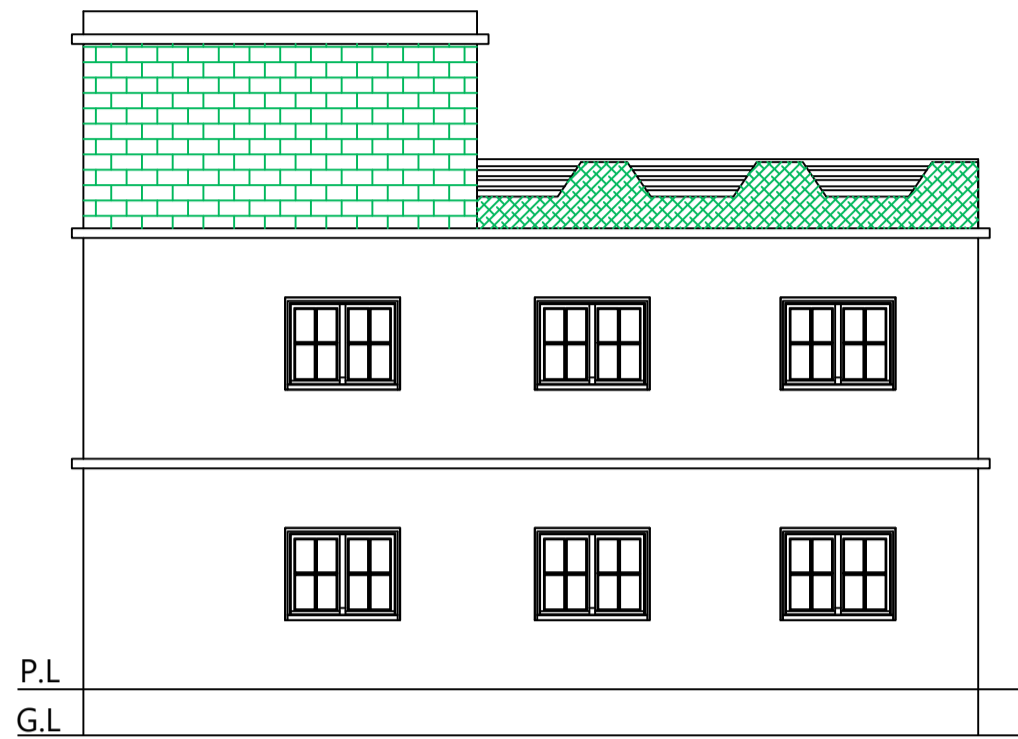

RIGHT ELEVATION SCALE 1:100

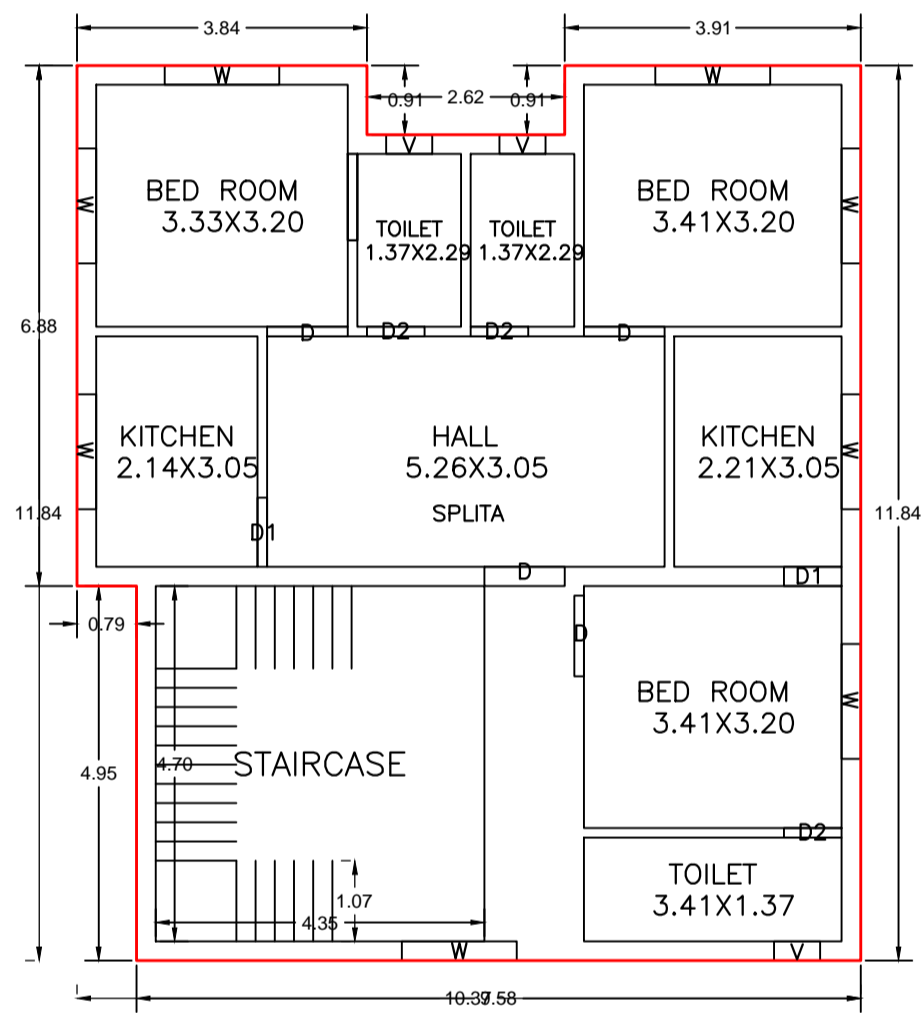

FIRST FLOOR PLAN (Proposed) SCALE 1:100

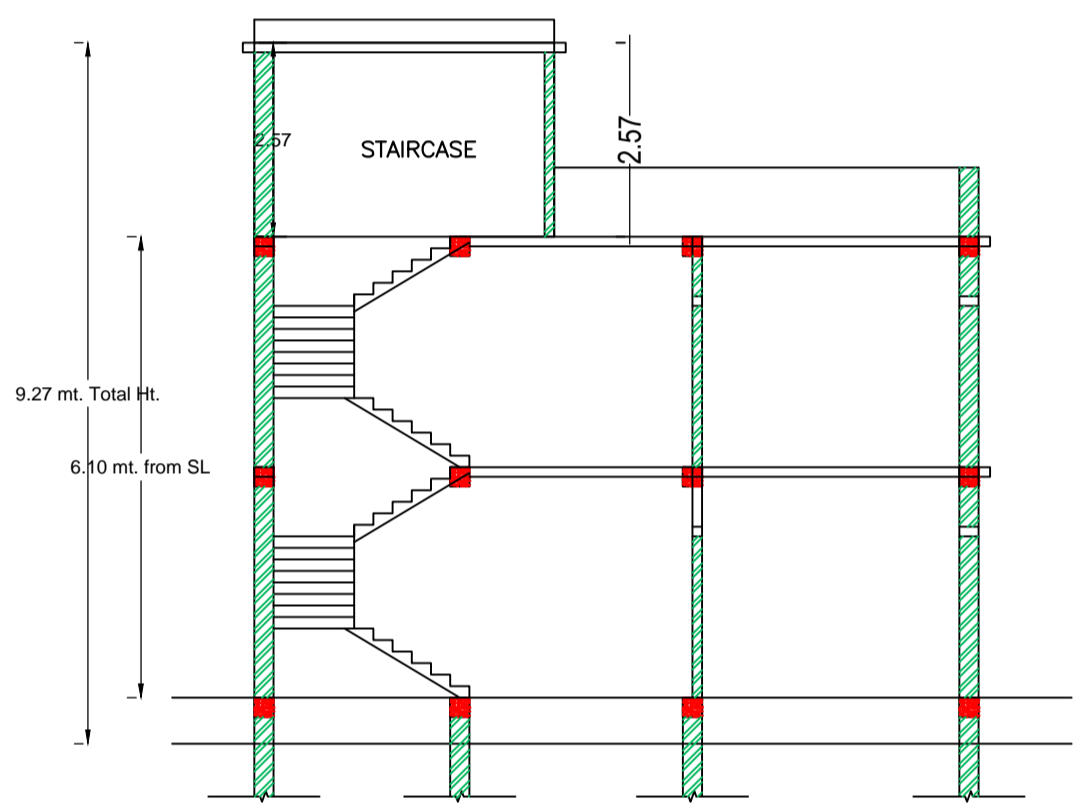

SECTION ON SCALE 1:100

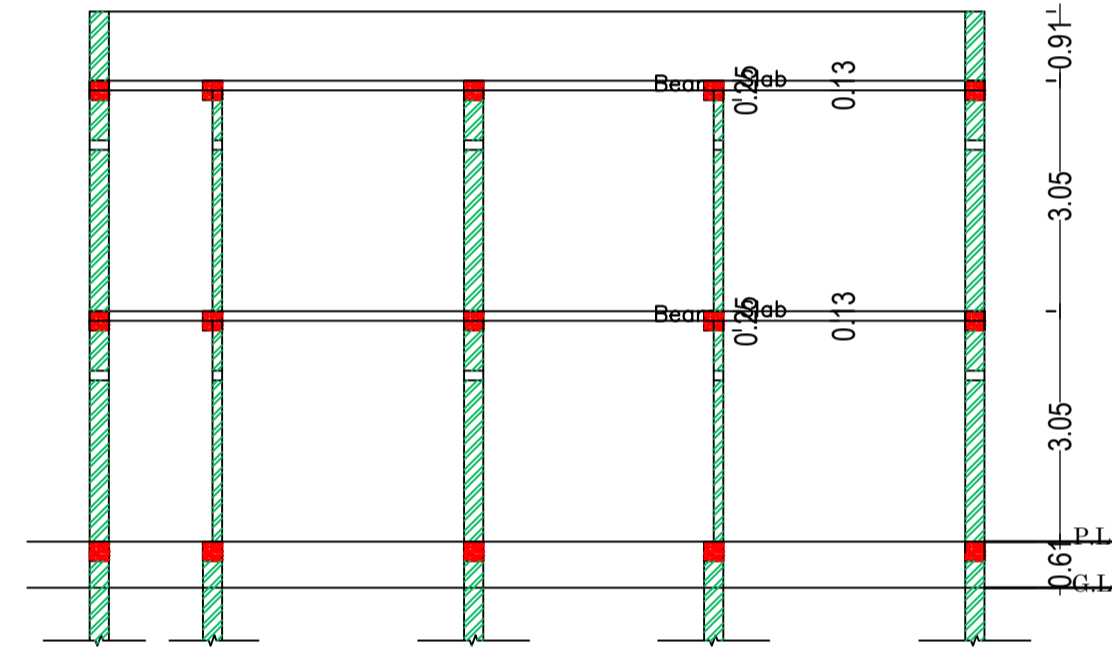

SECTION ON SCALE 1:100

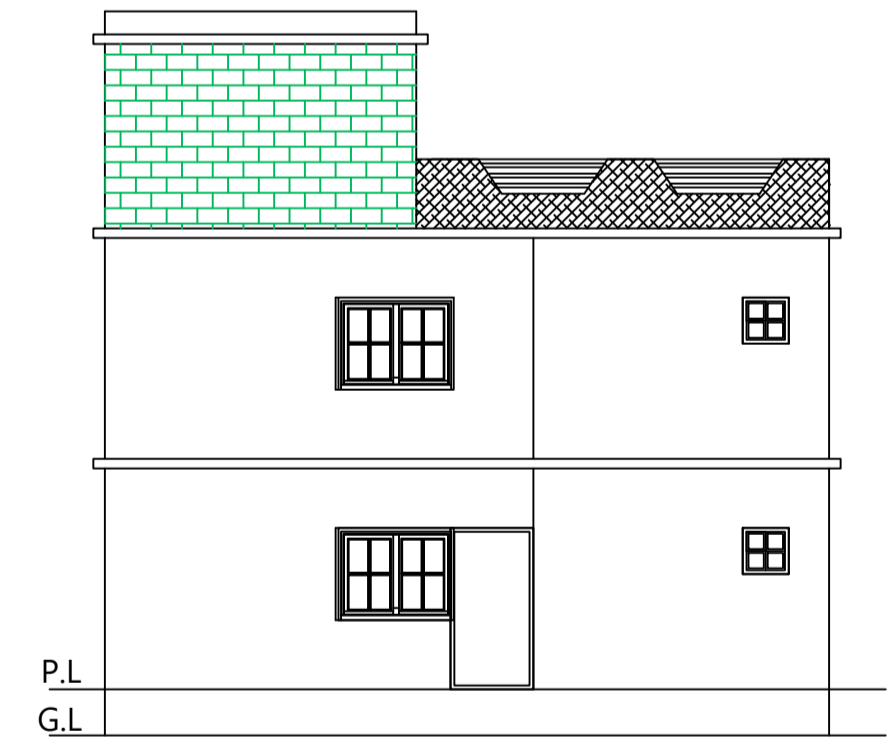

FRONT SIDE ELEVATION SCALE 1:100

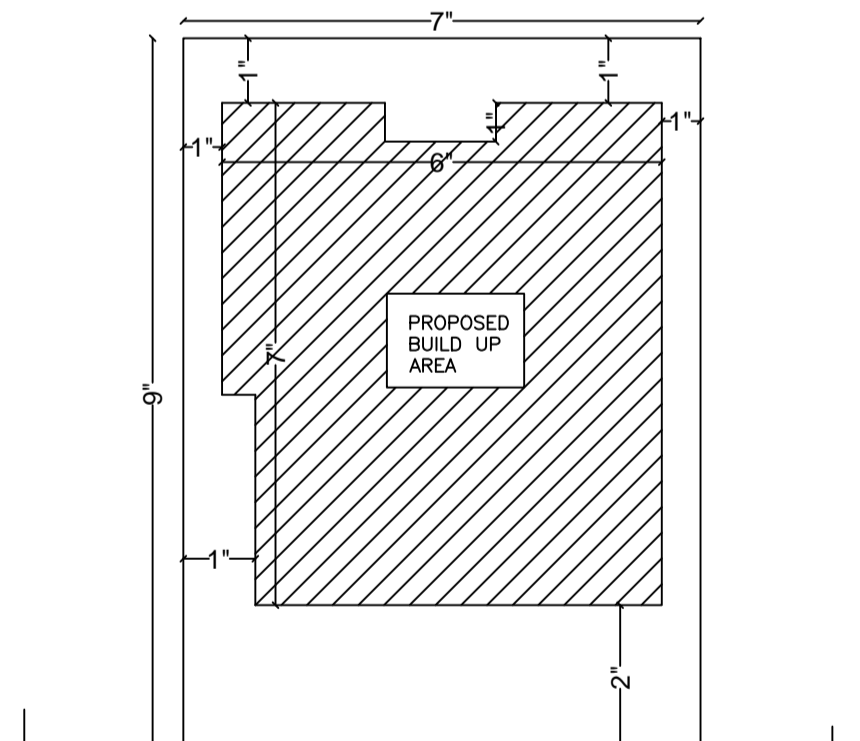

KEY PLAN SCALE 1:200

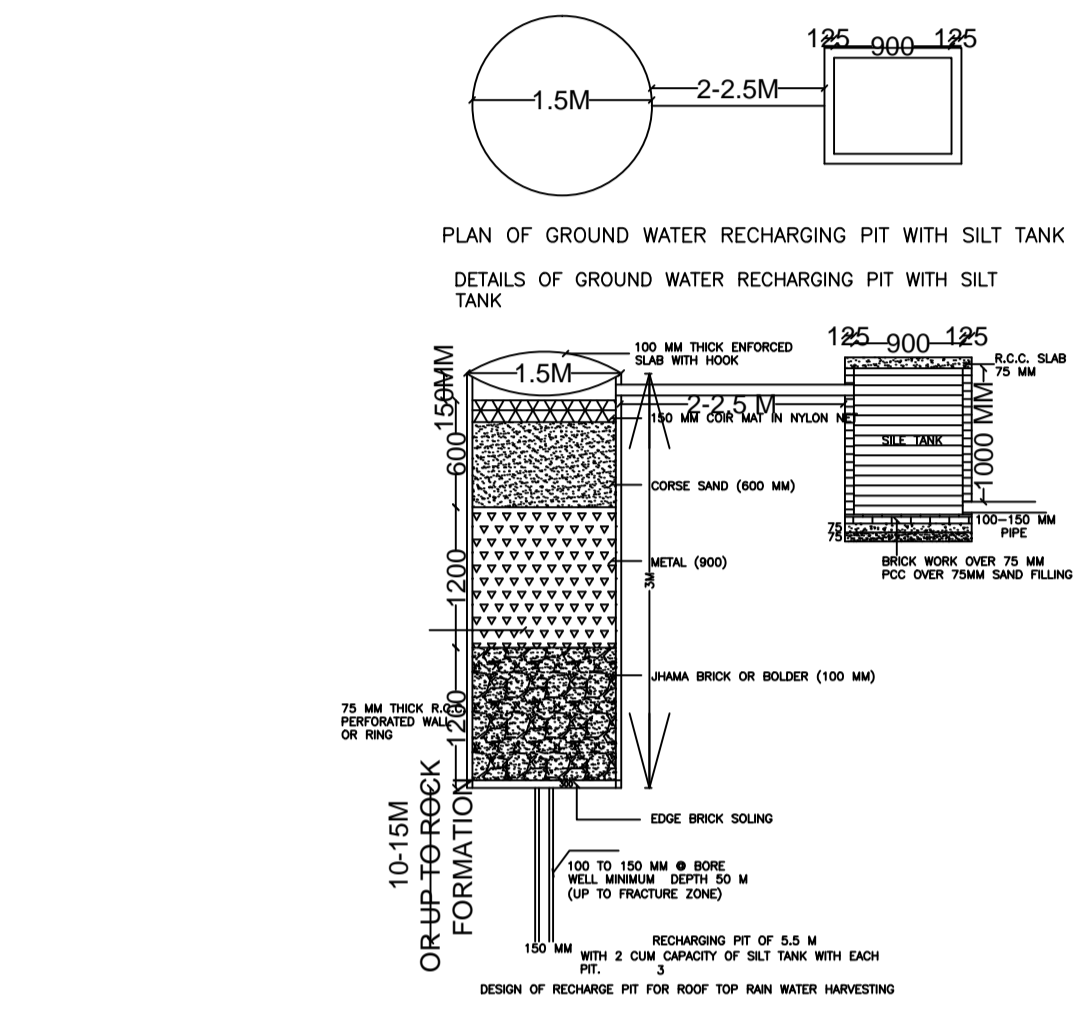

DETAILS OF GROUND WATER RECHARGING PIT WITH SILT TANK

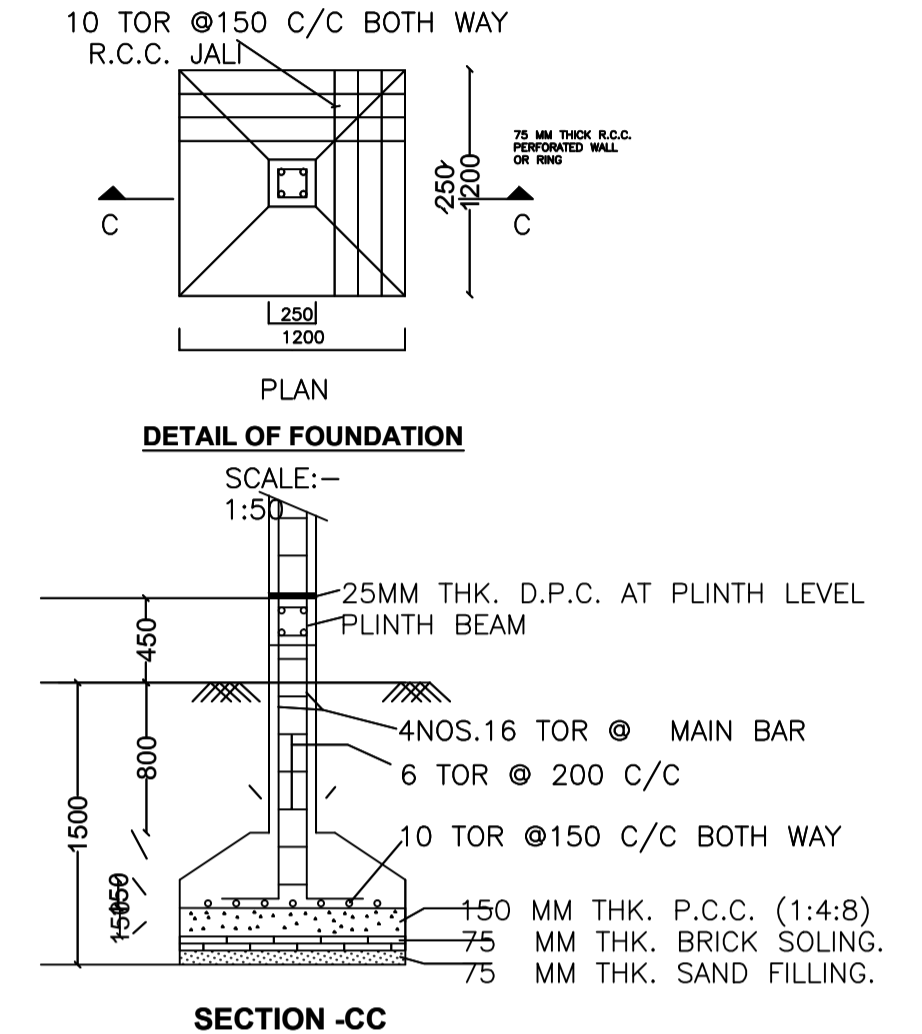

DETAIL OF FOUNDATION SCALE: 1:50

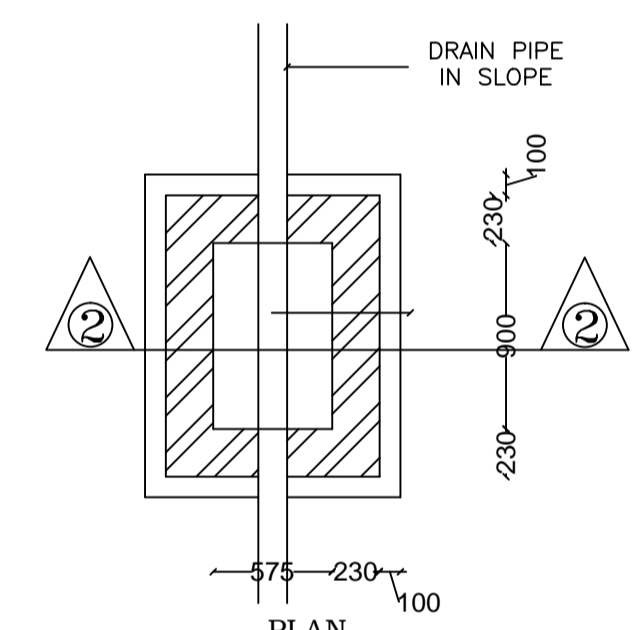

PLAN I.C. DETAILS R.C.C. COVER

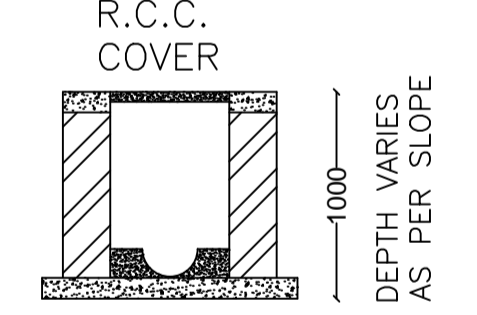

SECTION AT 2-2

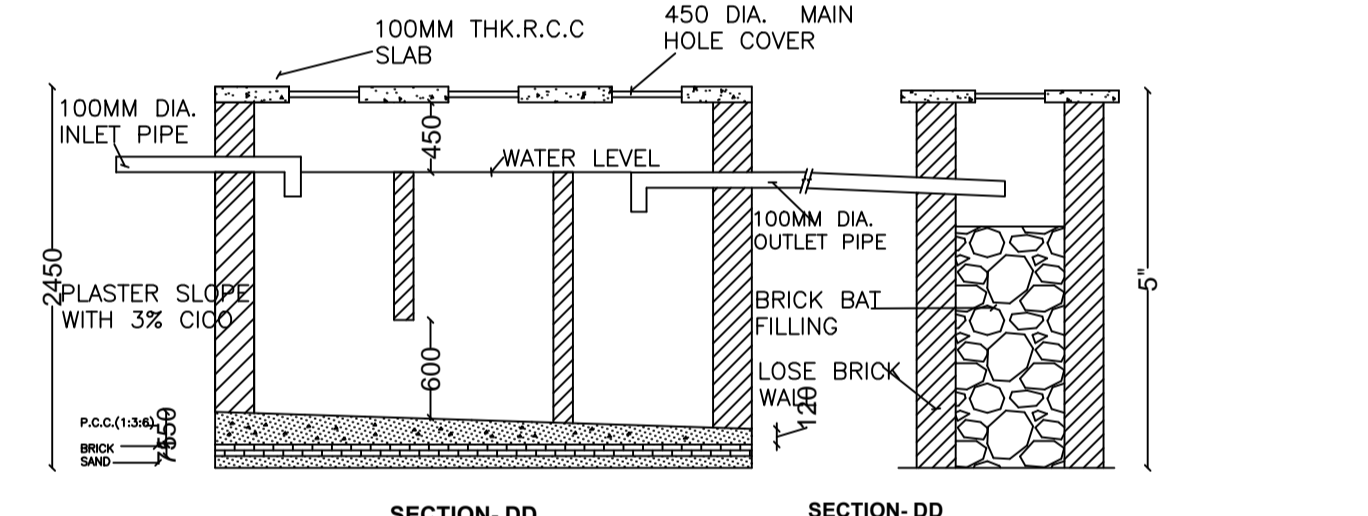

SECTION-DD

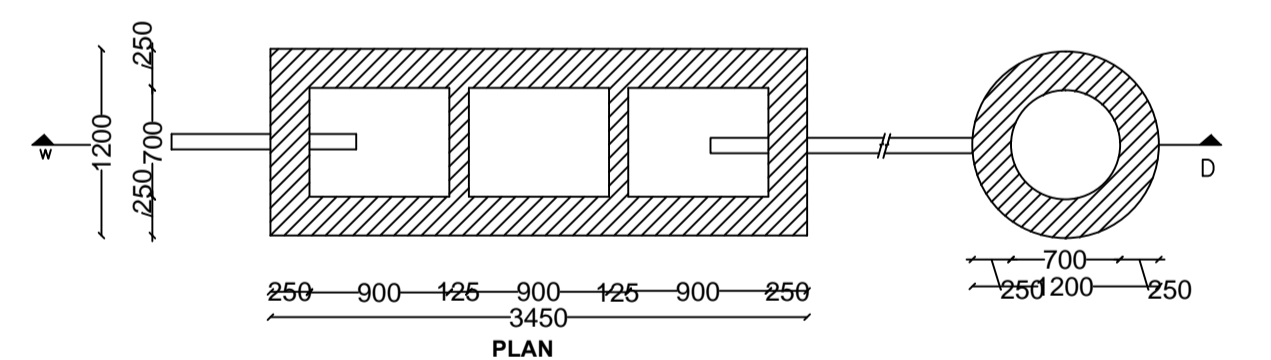

DETAIL OF SEPTIC TANK & SOAKPIT. SCALE - 1:50

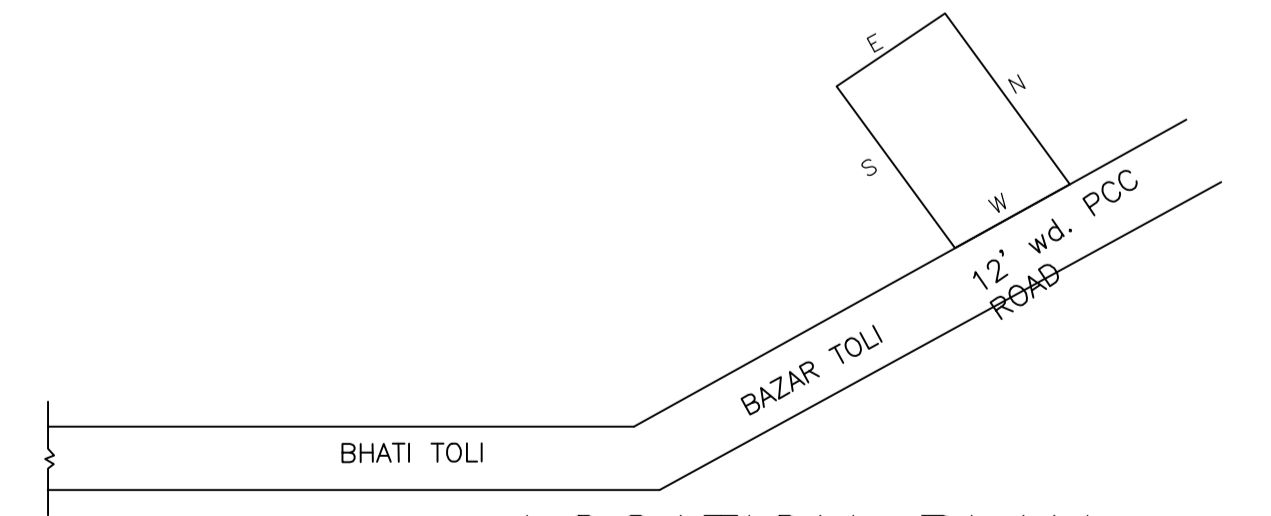

LOCATION PLAN NOT IN SCALE

Building :A1 (RESIDENTIAL)

Floor Name	Total Built Up Area (Sq.mt.)	Proposed FAR Area (Sq.mt.) Resi.	Total FAR Area (Sq.mt.)	Total Consumed Additional FAR Area (Sq.mt.)	Tnmt (No.)
Ground Floor	116.45	116.45	116.45	116.45	01
First Floor	116.45	116.45	116.45	116.45	00
Terrace Floor	0.00	0.00	0.00	0.00	00
Total:	232.90	232.90	232.90	232.90	01
Total Number of Same Buildings	1				
Total:	232.90	232.90	232.90	232.90	01

SCHEDULE OF DOOR:

BUILDING NAME	NAME	LENGTH	HEIGHT	NOS
A1 (RESIDENTIAL)	D2	0.76	2.10	06
A1 (RESIDENTIAL)	D1	0.76	2.10	02
A1 (RESIDENTIAL)	D1	0.91	2.10	02
A1 (RESIDENTIAL)	D	1.06	2.10	02
A1 (RESIDENTIAL)	D	1.07	2.10	06

SCHEDULE OF WINDOW/VENTILATION:

BUILDING NAME	NAME	LENGTH	HEIGHT	NOS
A1 (RESIDENTIAL)	V	0.61	1.20	06
A1 (RESIDENTIAL)	W	1.52	1.20	16

UnitBUA Table for Building :A1 (RESIDENTIAL)

FLOOR	Name	UnitBUA Type	UnitBUA Area	Carpet Area	No. of Rooms	No. of Tenement
GROUND FLOOR PLAN	SPLITA	FLAT	155.04	154.75	9	1
FIRST FLOOR PLAN	SPLITA	FLAT	0.00	0.00	9	0
Total:	-	-	155.04	154.75	18	1

LTP NAME AND SIGNATURE	STRUCTURAL ENG'S NAME AND SIGNATURE	BUILDER NAME AND SIGNATURE	DIGITAL SIGNATURE
DEELIP KUMAR SINPC/DFTMN/0003/2023			