

Proposal Basic Information	
Proposal File No.	SNPC/BP/0006/W04/2018
Owner Name	PURNA CHANDRA SOREN
Khata No	108
Plot No	104/a
Village Name	Hansahudi
Use	Residential
SubUse	Residential Bldg/Apartment

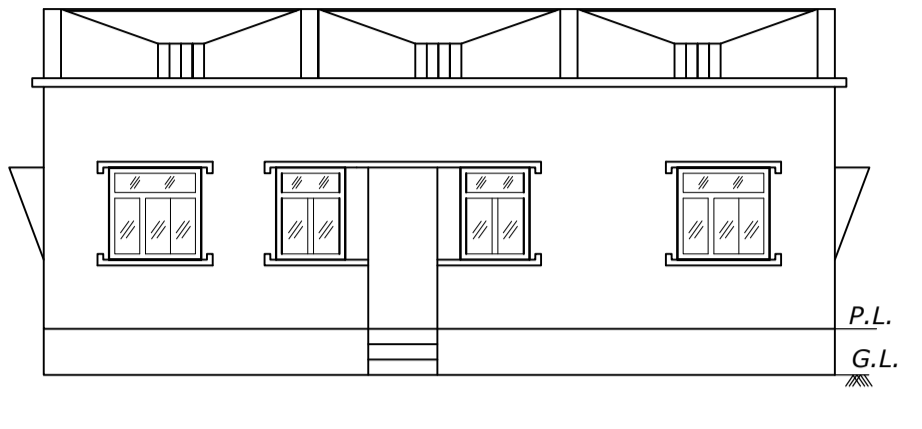
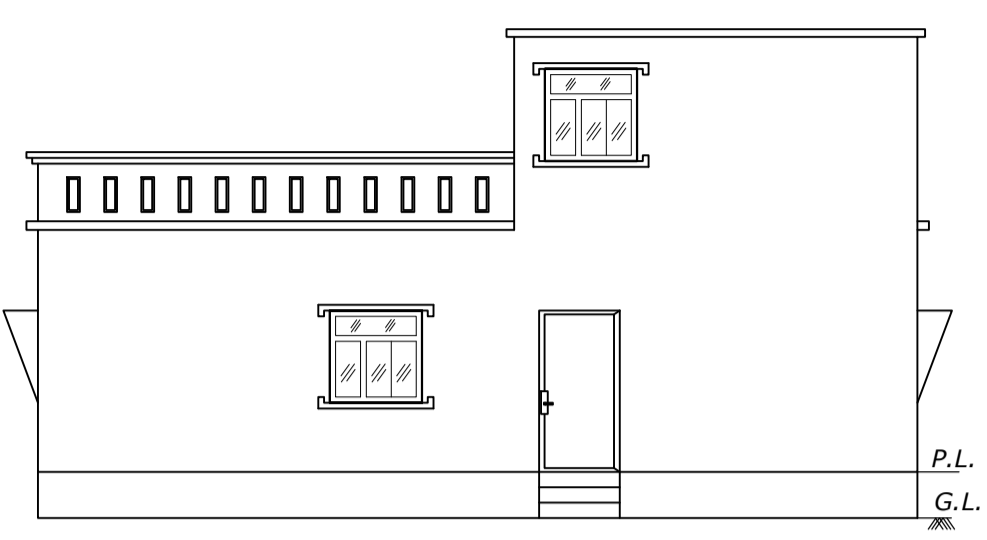
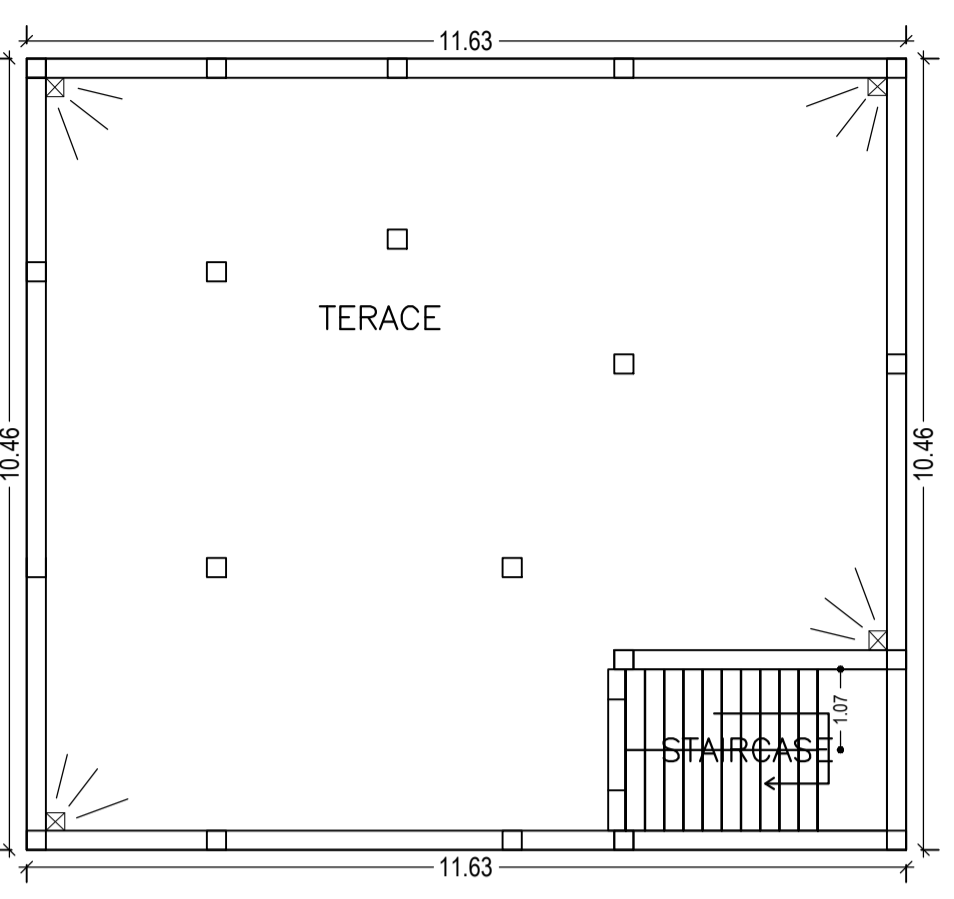
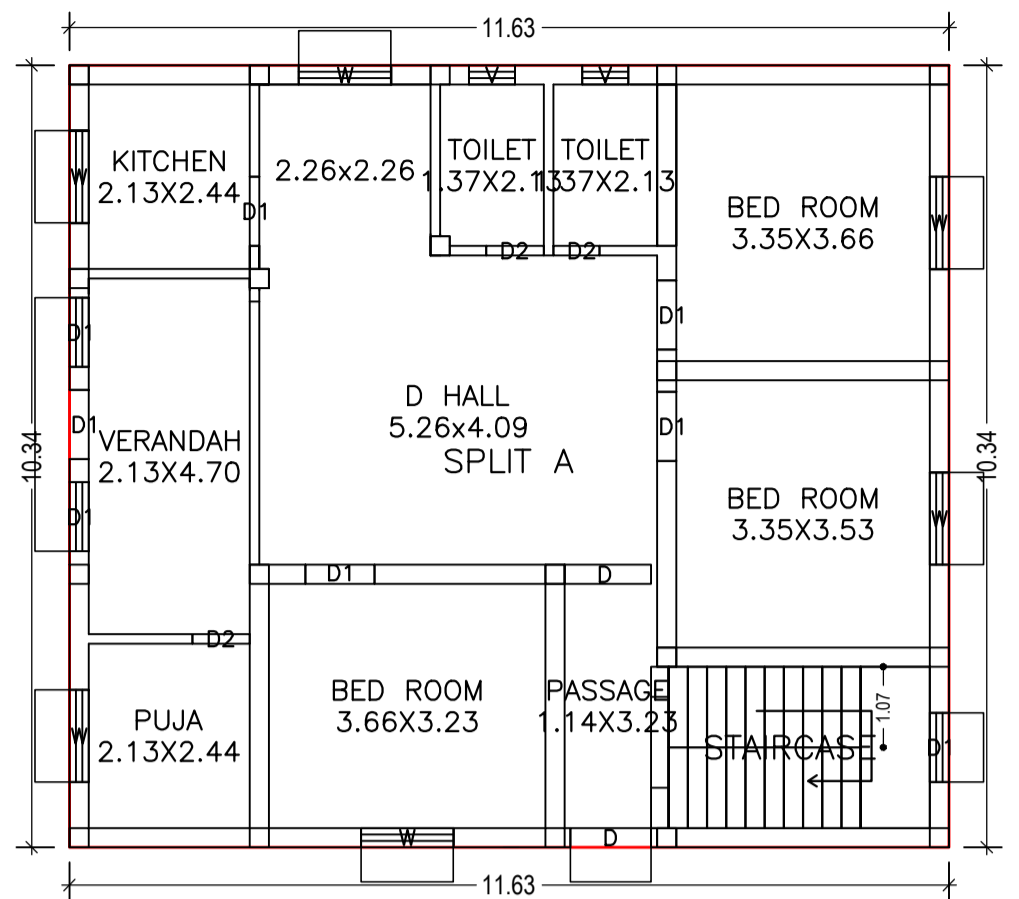
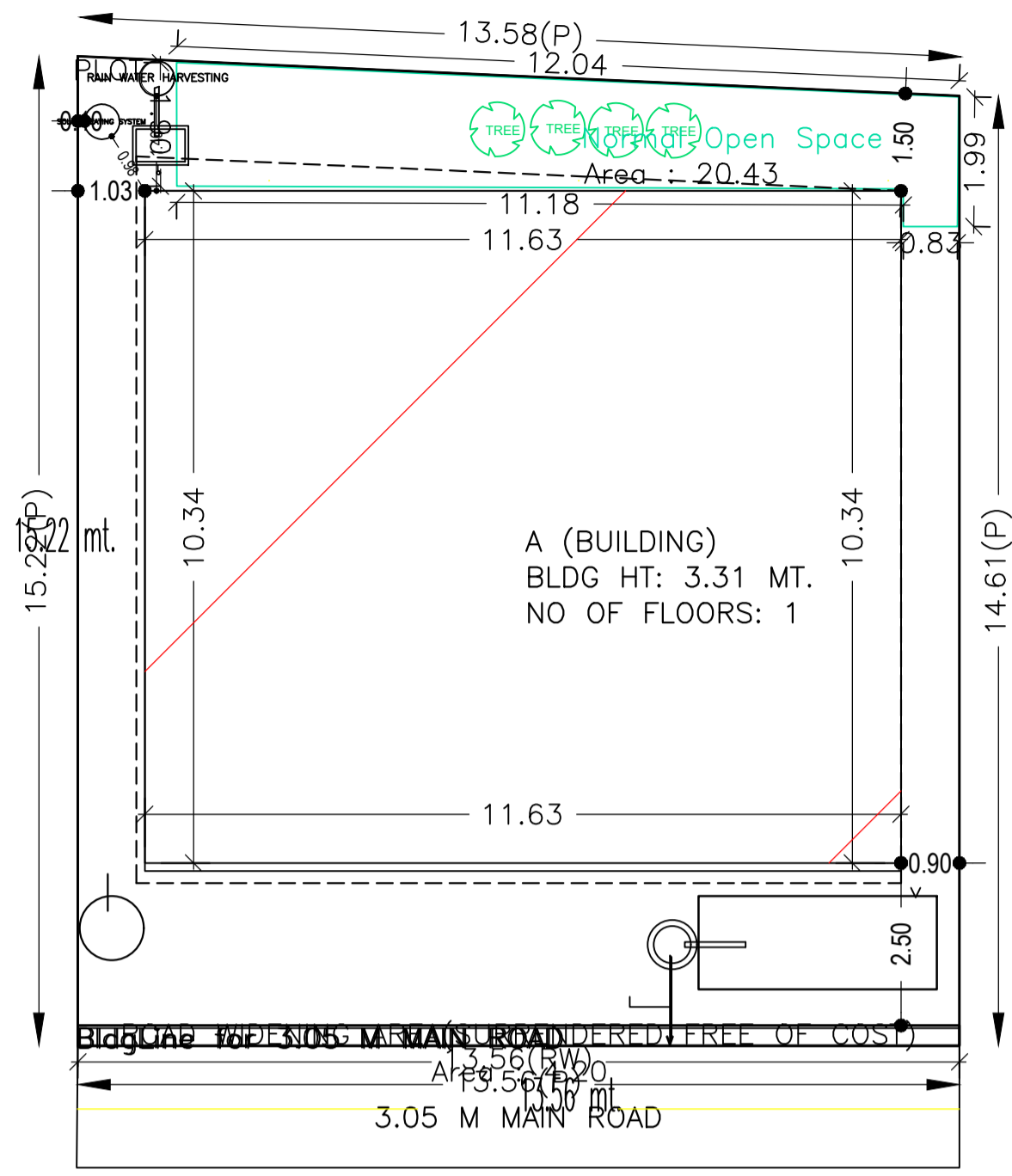

EAST SIDE ELEVATION

FRONT ELEVATION

GROUND FLOOR PLAN (Proposed) (SCALE 1:100)

TERRACE FLOOR PLAN (SCALE 1:100)

LOCATION PLAN NOT TO SCALE

SERAIKELLA MUNICIPALITY  
WARD NO - 04  
THANA-SERAIKELLA(301)  
DIST-SERAIKELLA-KHARSAWAN

AREA STATEMENT		VERSION NO. : 1.0.42
SARAIKELA NAGAR PANCHAYAT		VERSION DATE: 29/04/2019
PROJECT DETAIL:		
Region: JHARKHAND URBAN LOCAL BODIES	Plot Use: Residential	
District: SERAIKELA	Plot SubUse: Residential Bldg/Apartment	
Authority: SERAIKELA NAGAR PANCHAYAT	PlotNearbyReligiousStructure: NA	
Inward No: SNPC/BP/0006/W04/2018	Plot/SubPlot No: 104/a	
Application Type: General Proposal	North Road Width - 3.05	
Project Type: Building Permission	South Road Width - 2.43	
Nature of Development: New	East Road Width - 3.05	
Location of Development Area: Old Area	West: Plot No. - PART OF PLOT 104/MUNI DEVI	
AREA DETAILS:		
AREA OF PLOT (Minimum)	(A)	SQ.MT. 202.33
Deduction for NetPlot Area		
Surrender Free of Cost		4.20
Total		4.20
NET AREA OF PLOT(Gross Plot Area - Deduction from Gross Plot area)	(A-Deductions)	198.12
Deduction for Balance Plot Area(from Gross Plot Area)		
Surrender Free of Cost		4.20
Common Plot		20.43
Total		24.64
BALANCE AREA OF PLOT(Net Plot Area - Recreational/Amenity space)	(A-Deductions)	177.69
PLOT AREA FOR COVERAGE(Net Plot Area)	(A-Deductions)	198.12
Plot Area for FAR (Net Plot Area + RoadWidening Area)	(A-Deductions)	202.33
COVERAGE CHECK		
Permissible Coverage area ( 70.00 % )		138.68
Proposed Coverage Area ( 60.72 % )		120.30
Total Prop. Coverage Area ( 60.72 % )		120.30
Balance coverage area ( 9.28 % )		18.38
FAR CHECK		
Perm. FAR area ( 1.20 )		242.80
Total Perm. FAR area		242.80
Residential FAR		120.30
Proposed FAR Area		120.30
Total Proposed FAR Area		120.30
Consumed FAR (Factor)		0.59
Balance FAR Area		122.50
BUILT UP AREA CHECK		
Total Proposed BuiltUp Area		120.30
ARCHITECT (Regd)		DURGA PRASAD DUBEY
ENGINEER (Regd)		
SUPERVISOR (Regd)		
OWNER (Regd)		PURNA CHANDRA SOREN
DEVELOPMENT AUTHORITY LOCAL BODY		

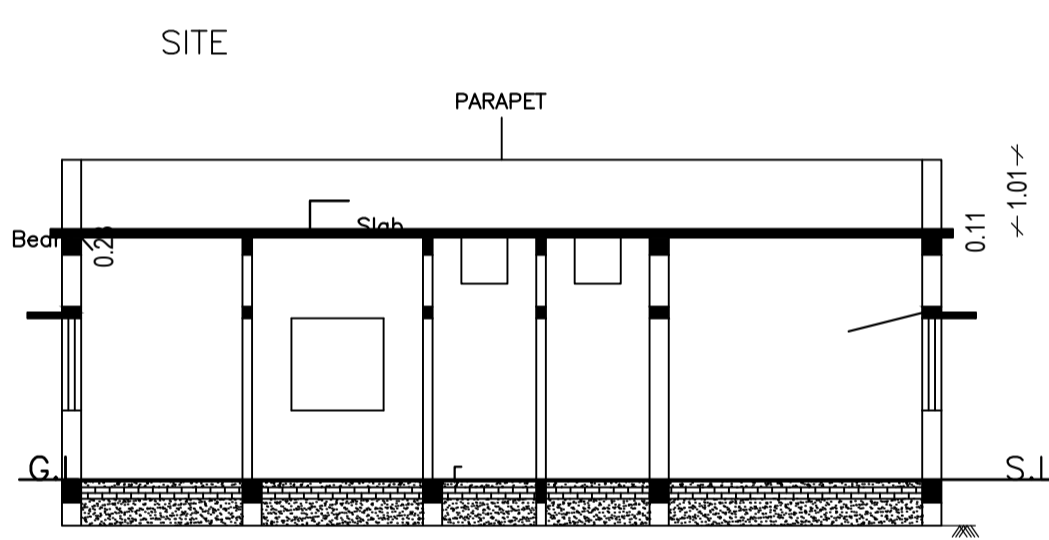
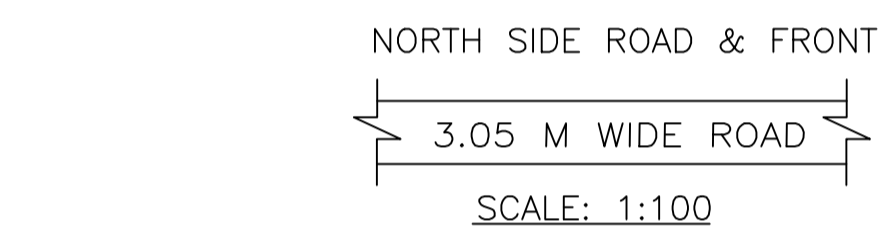

C/S AT A-A'

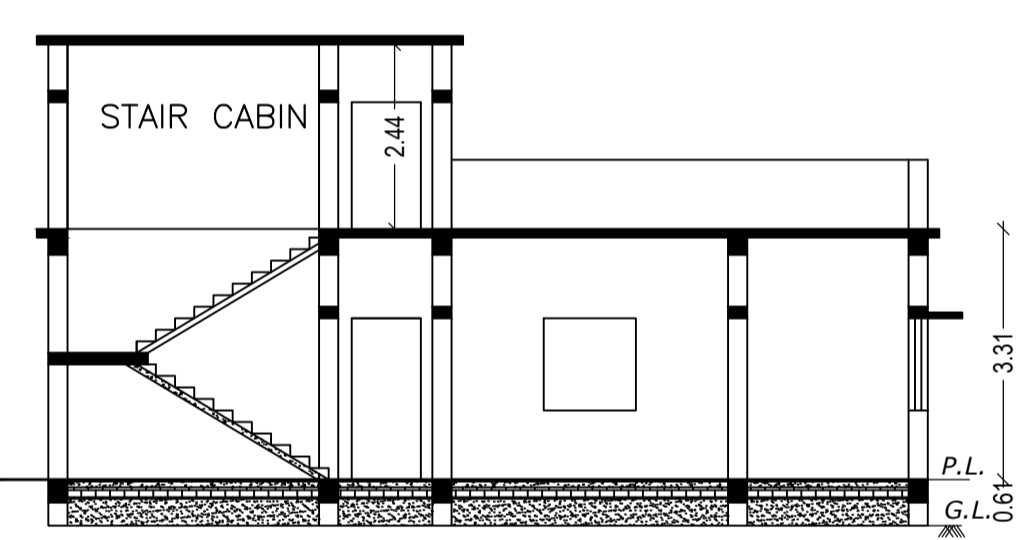

C/S AT X-X'

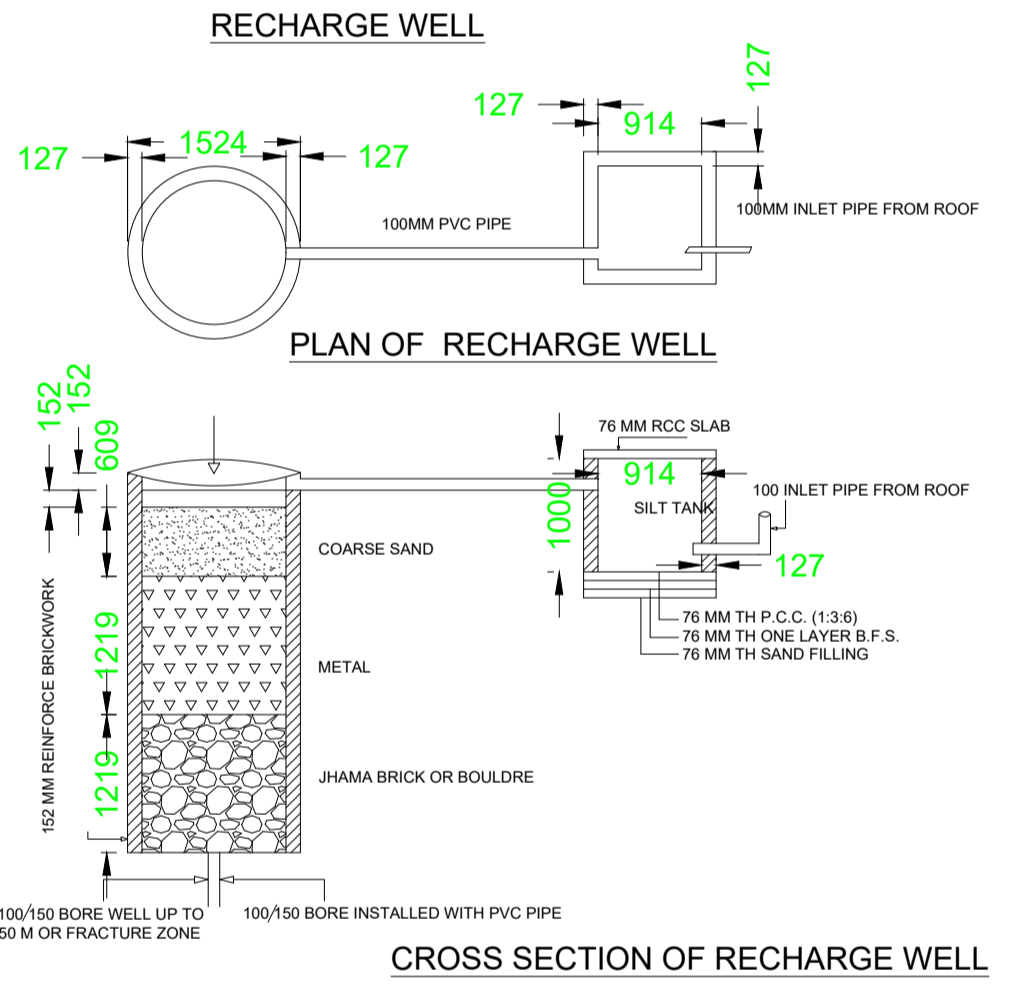

CROSS SECTION OF RECHARGE WELL

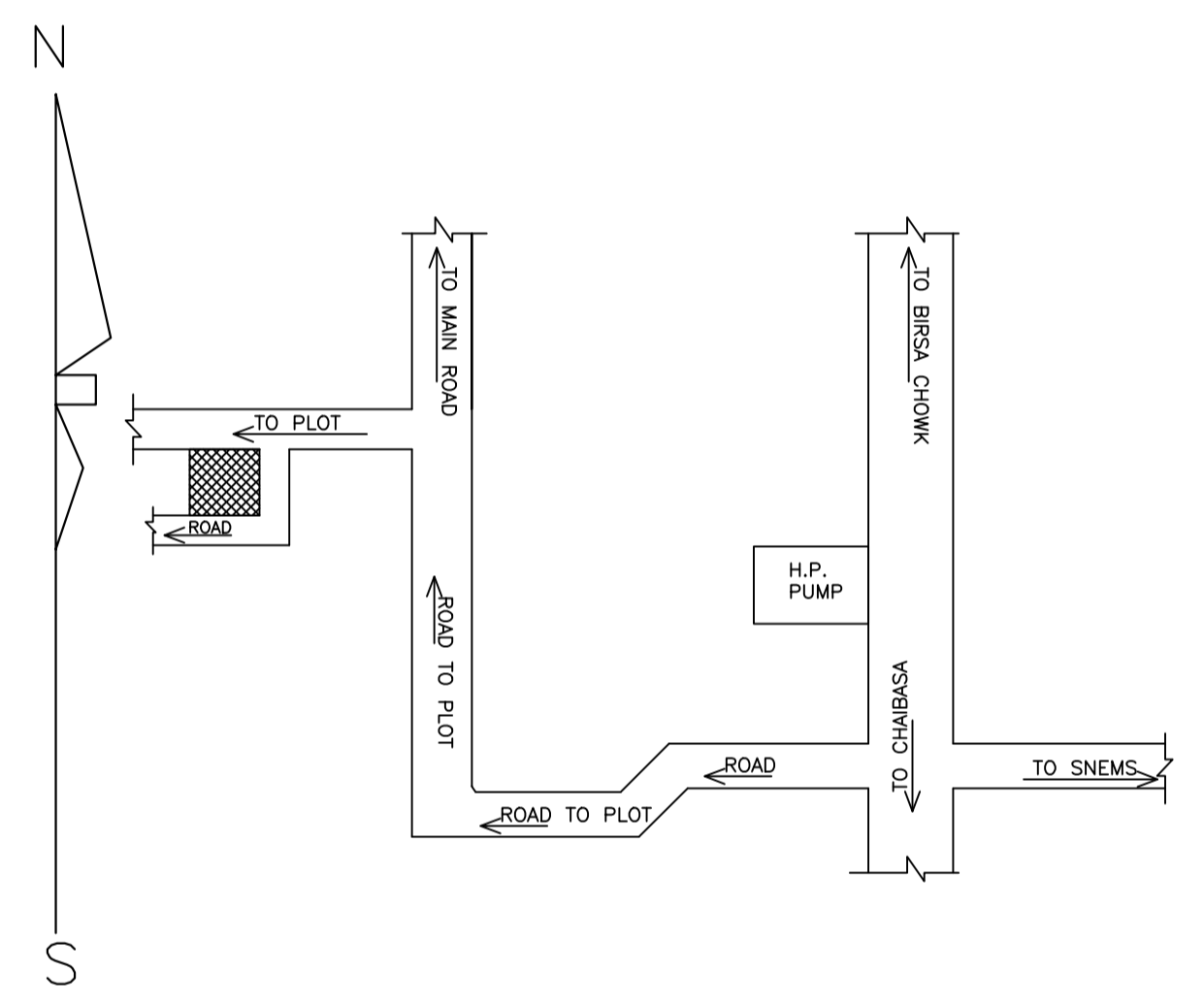

N.B.-NEW WORK SITE SHOWN IN [Symbol]

SCHEDULE OF DOOR:

BUILDING NAME	NAME	LENGTH	HEIGHT	NOS
A (BUILDING)	D2	0.61	2.10	01
A (BUILDING)	D2	0.76	2.10	02
A (BUILDING)	D1	0.91	2.10	07
A (BUILDING)	D	1.07	2.10	01
A (BUILDING)	D	1.14	2.10	01

SCHEDULE OF WINDOW/VENTILATION:

BUILDING NAME	NAME	LENGTH	HEIGHT	NOS
A (BUILDING)	V	0.61	1.20	02
A (BUILDING)	W	1.22	1.20	02
A (BUILDING)	W	1.23	1.20	04

UnitBUA Table for Building :A (BUILDING)

FLOOR	Name	UnitBUA Type	UnitBUA Area	Carpet Area	No. of Rooms	No. of Tenement
GROUND FLOOR PLAN	SPLIT A	FLAT	100.60	100.05	10	1
Total:	-	-	100.60	100.05	10	1

FAR & Tenement Details (Table 4c-1)

Building	No. of Same Bldg	Total Built Up Area (Sq.mt.)	Proposed FAR Area (Sq.mt.) Resi.	Total FAR Area (Sq.mt.)	Total Consumed Additional FAR Area (Sq.mt.)	Tnmt (No.)
A (BUILDING)	1	120.30	120.30	120.30	120.30	01
Grand Total	-	120.30	120.30	120.30	120.30	01

SEPTIK TANK & SOAK PIT

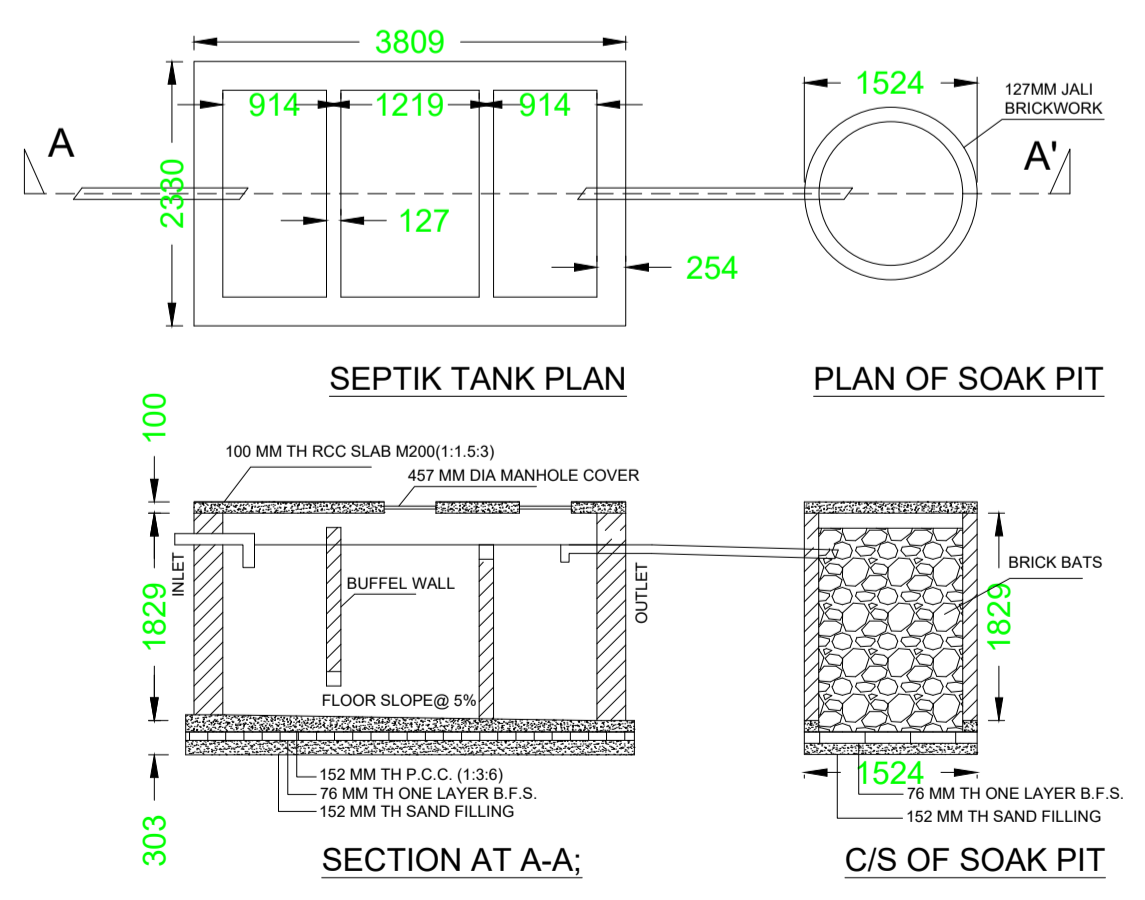

SECTION AT A-A'

C/S OF SOAK PIT

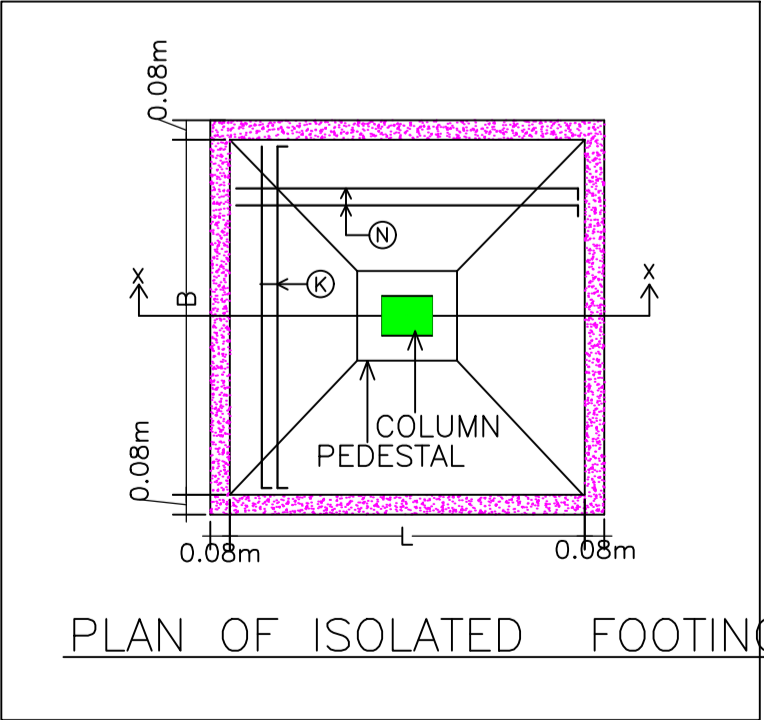

PLAN OF ISOLATED FOOTING

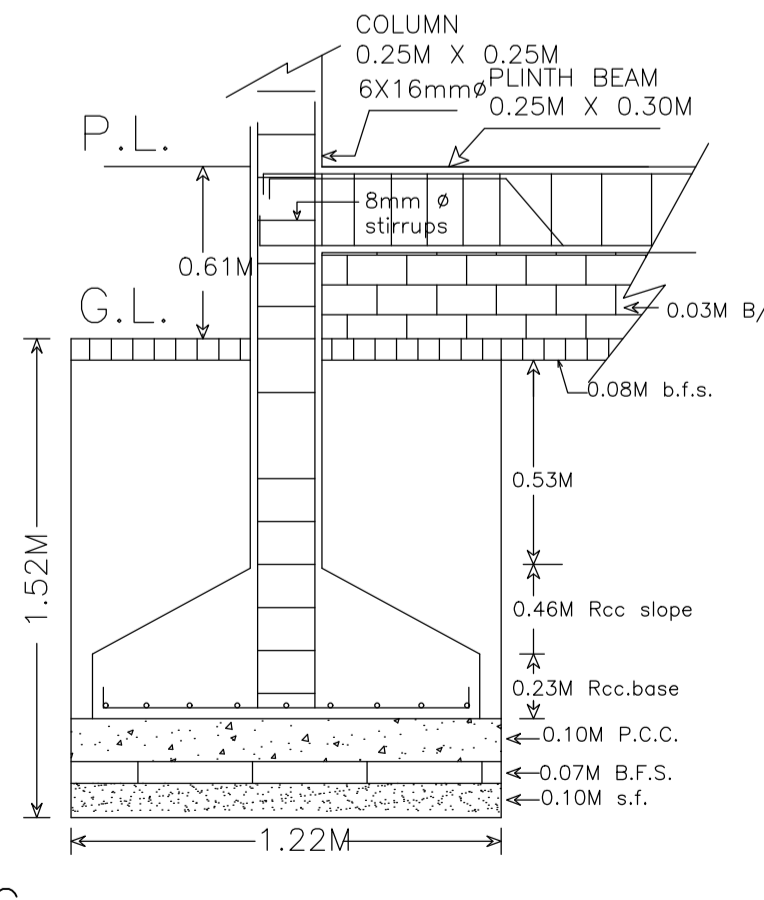

C/S OF FOOTING

Floor Name	Total Built Up Area (Sq.mt.)	Proposed FAR Area (Sq.mt.) Resi.	Total FAR Area (Sq.mt.)	Total Consumed Additional FAR Area (Sq.mt.)	Tnmt (No.)
Ground Floor	120.30	120.30	120.30	120.30	01
Terrace Floor	0.00	0.00	0.00	0.00	00
Total :	120.30	120.30	120.30	120.30	01
Total Number of Same Buildings :	1				
Total :	120.30	120.30	120.30	120.30	01

COLOR INDEX	
PLOT BOUNDARY	[Black Line]
ABUTTING ROAD	[Green Line]
PROPOSED CONSTRUCTION	[Red Line]
COMMON PLOT	[Yellow Line]
ROAD WIDENING AREA	[Blue Line]
EXISTING (To be retained)	[Blue Line]
EXISTING (To be demolished)	[Yellow Line]

Floor Name	Building Name A (BUILDING)		Total	
	Proposed Built Up Area (Sq.mt.)	Proposed FAR Area (Sq.mt.)	Total Proposed Built Up Area (Sq.mt.)	Total FAR Area (Sq.mt.)
Ground Floor	120.30	120.30	120.30	120.30
Terrace Floor	0.00	0.00	0.00	0.00
Total :	120.30	120.30	120.30	120.30

Building Name	Building Use	Building SubUse	Building Structure
A (BUILDING)	Residential	Bungalow/ Dwelling / Non Apartment	Non-Highrise

LTP NAME AND SIGNATURE	STRUCTURAL ENG'S NAME AND SIGNATURE	BUILDER NAME AND SIGNATURE	DIGITAL SIGNATURE
DURGA PRASAD DUBEY SNPC/ENG/0004/2017			