

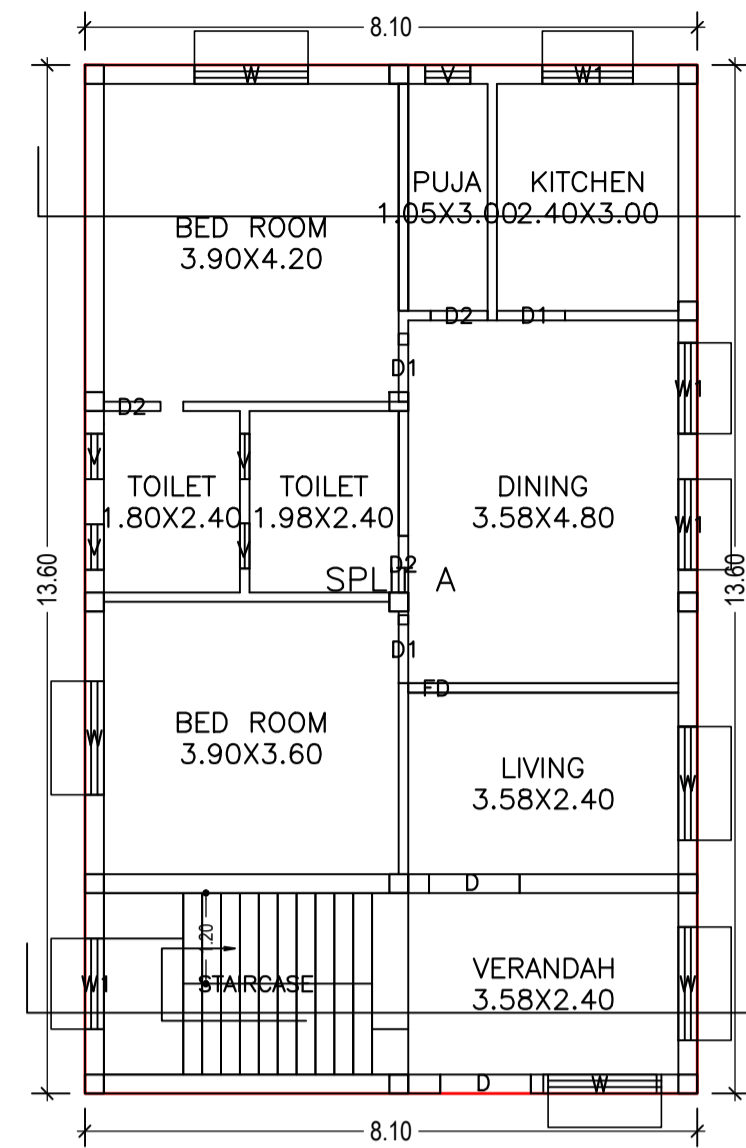

Proposal Basic Information

Proposal File No.	SNPC/BP/0023/W04/2018
Owner Name	DILIP KUMAR ACHARYA
Khata No	315
Plot No	315/A
Village Name	Hansahudi
Use	Residential
SubUse	Residential Bldg/Apartment



GROUND FLOOR PLAN (Proposed) (SCALE 1:100)

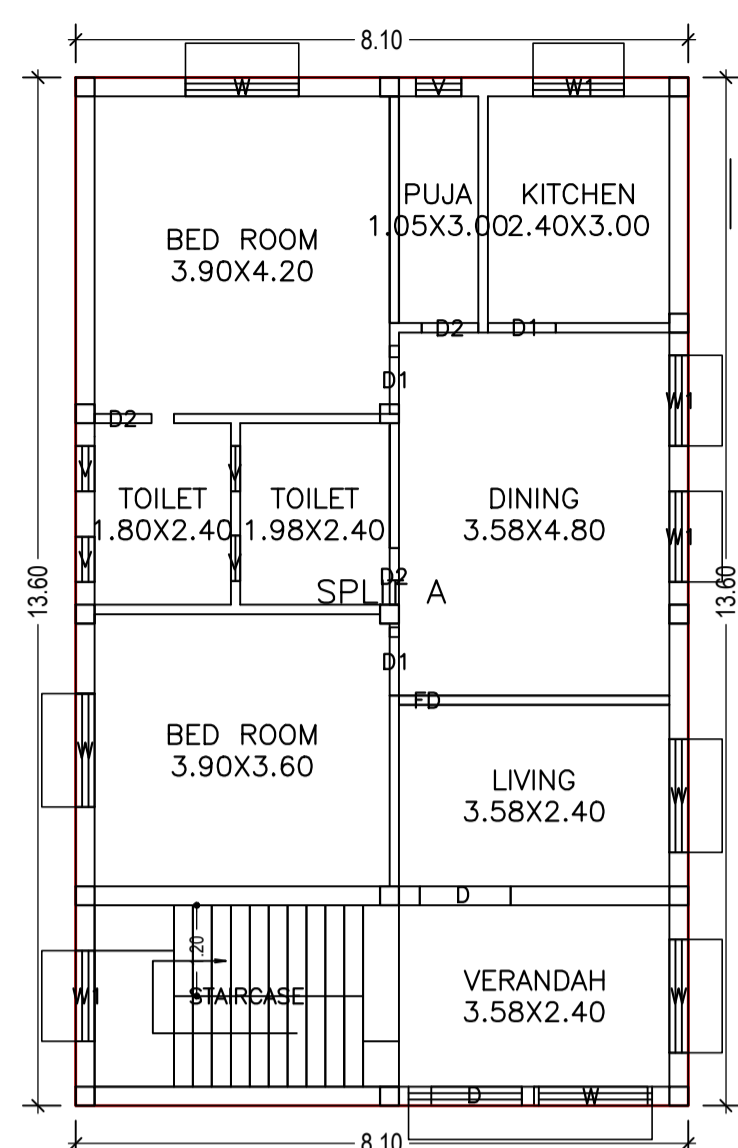

FIRST FLOOR PLAN (Proposed) (SCALE 1:100)

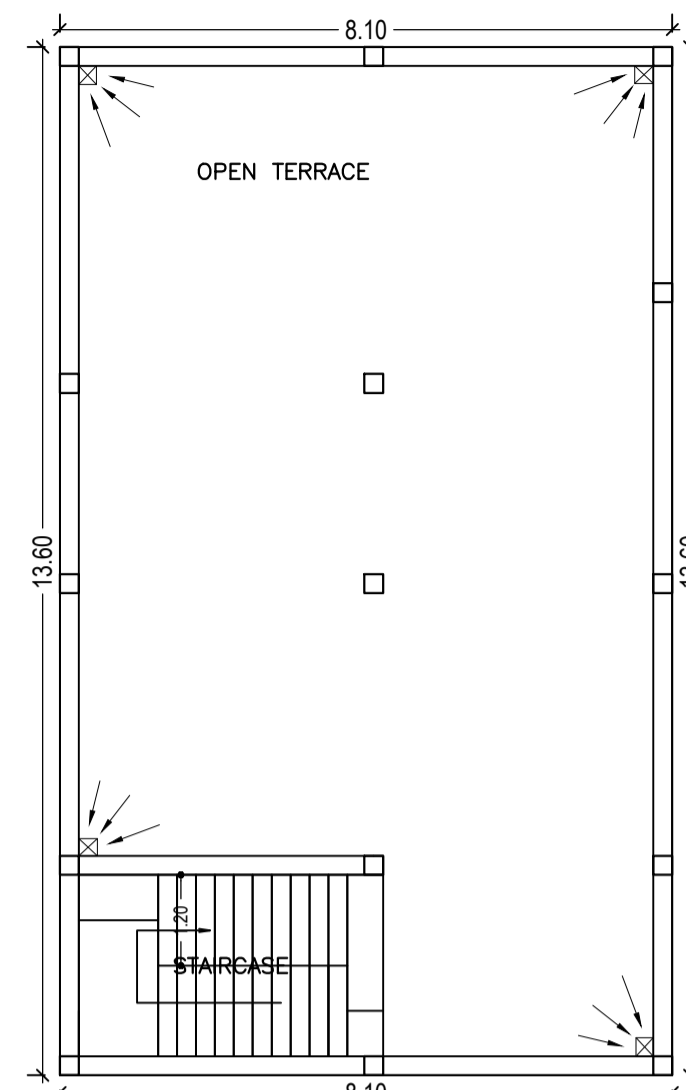

TERRACE FLOOR PLAN (SCALE 1:100)

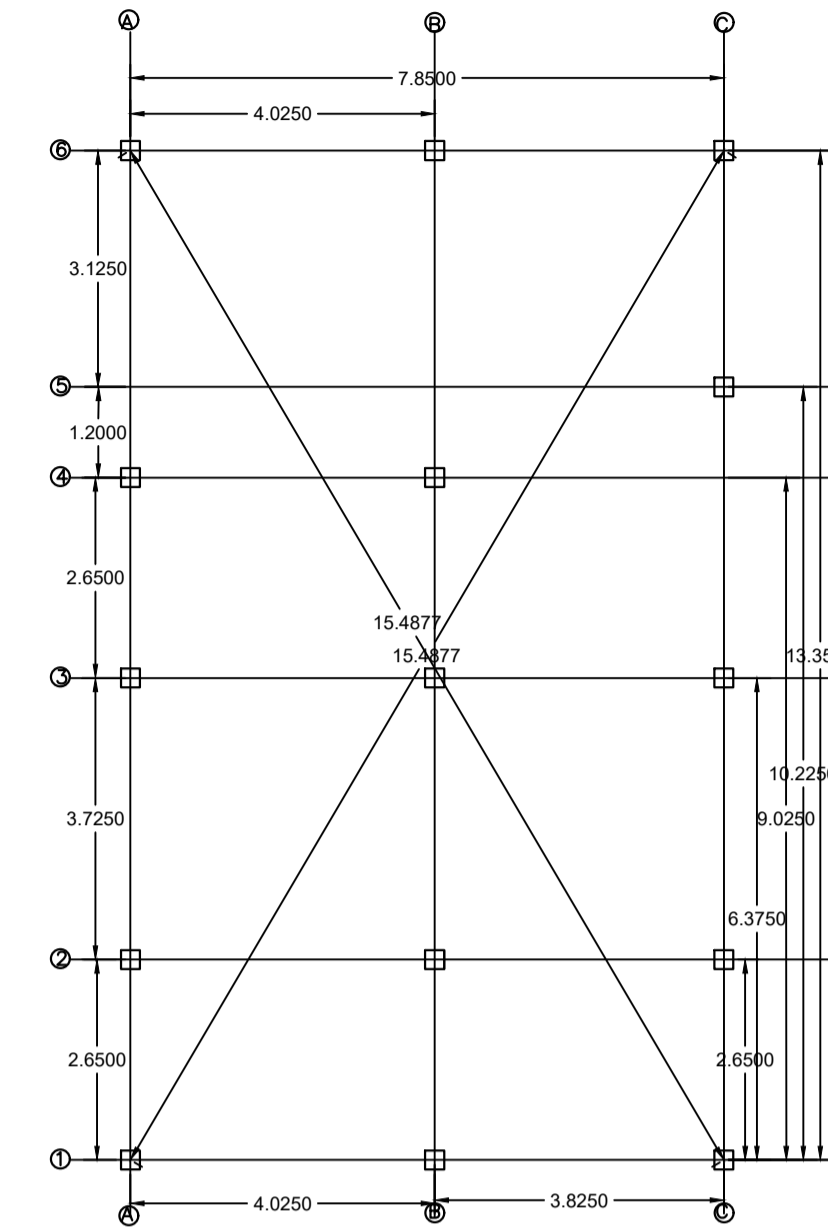

Building :A (RESIDENTIAL)

Floor Name	Total Built Up Area (Sq.mt.)	Proposed FAR Area (Sq.mt.) Resi.	Total FAR Area (Sq.mt.)	Total Consumed Additional FAR Area (Sq.mt.)	Tnmt (No.)
Ground Floor	110.16	110.16	110.16	110.16	01
First Floor	110.16	110.16	110.16	110.16	00
Terrace Floor	0.00	0.00	0.00	0.00	00
Total :	220.32	220.32	220.32	220.32	01
Total Number of Same Buildings :	1				
Total :	220.32	220.32	220.32	220.32	01

SCHEDULE OF DOOR:

BUILDING NAME	NAME	LENGTH	HEIGHT	NOS
A (RESIDENTIAL)	D2	0.75	2.10	06
A (RESIDENTIAL)	D1	0.90	2.10	06
A (RESIDENTIAL)	D	1.20	2.10	04
A (RESIDENTIAL)	FD	3.58	2.10	02

SCHEDULE OF WINDOW/VENTILATION:

BUILDING NAME	NAME	LENGTH	HEIGHT	NOS
A (RESIDENTIAL)	V	0.60	0.60	10
A (RESIDENTIAL)	W1	1.20	1.20	08
A (RESIDENTIAL)	W	1.50	1.20	10

UnitBUA Table for Building :A (RESIDENTIAL)

FLOOR	Name	UnitBUA Type	UnitBUA Area	Carpet Area	No. of Rooms	No. of Tenement
GROUND FLOOR PLAN	SPLIT A	FLAT	177.79	177.04	9	1
FIRST FLOOR PLAN	SPLIT A	FLAT	0.00	0.00	9	0
Total:	-	-	177.79	177.04	18	1

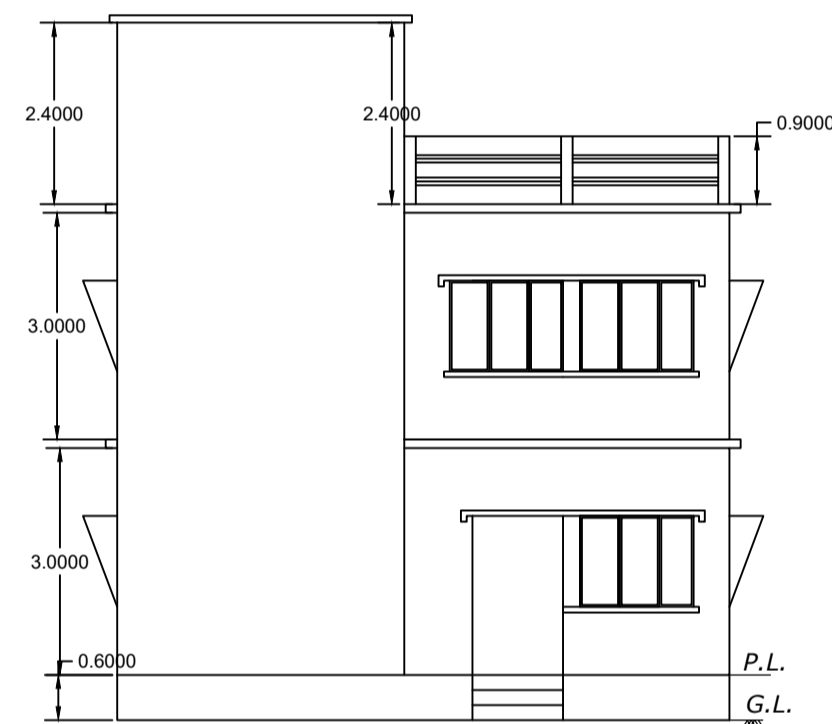

FRONT ELEVATION

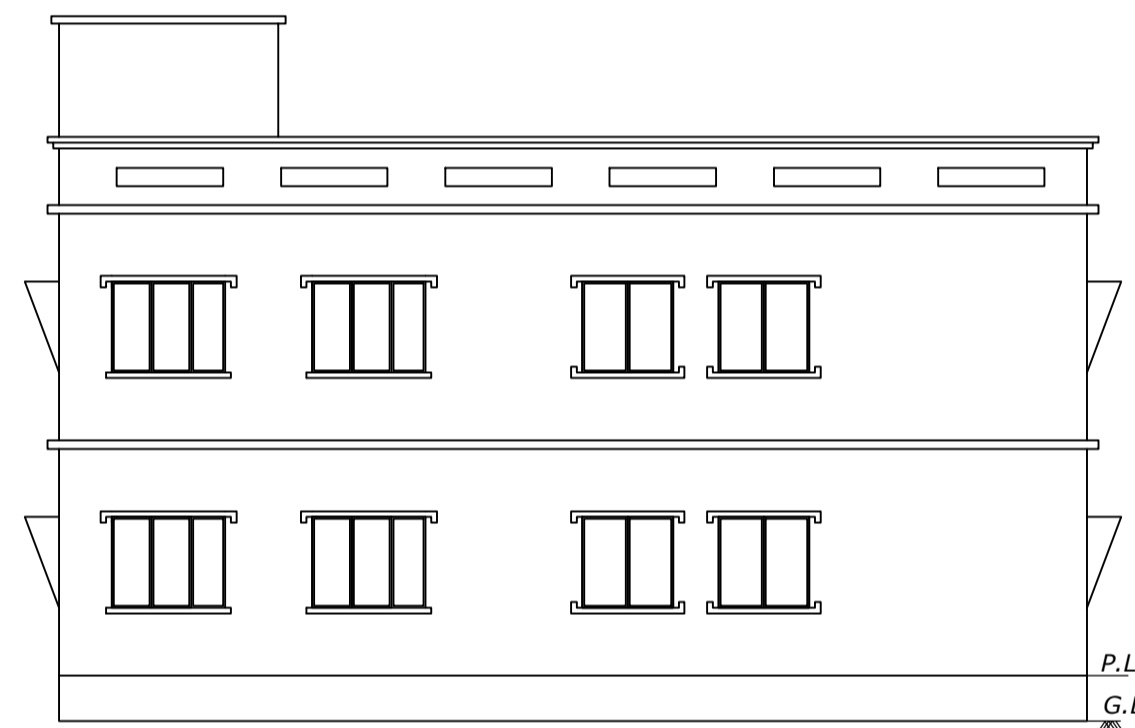

SOUTH SIDE ELEVATION

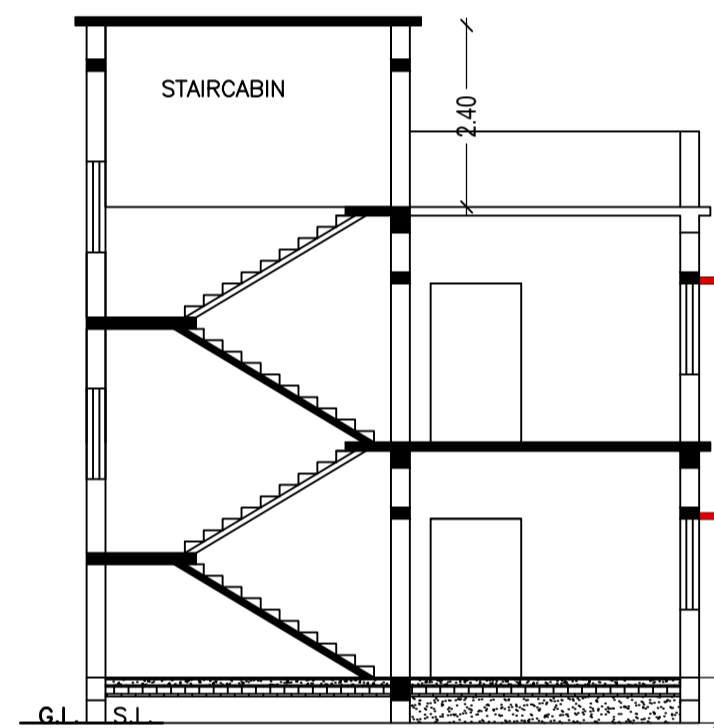

C/S AT X-X'

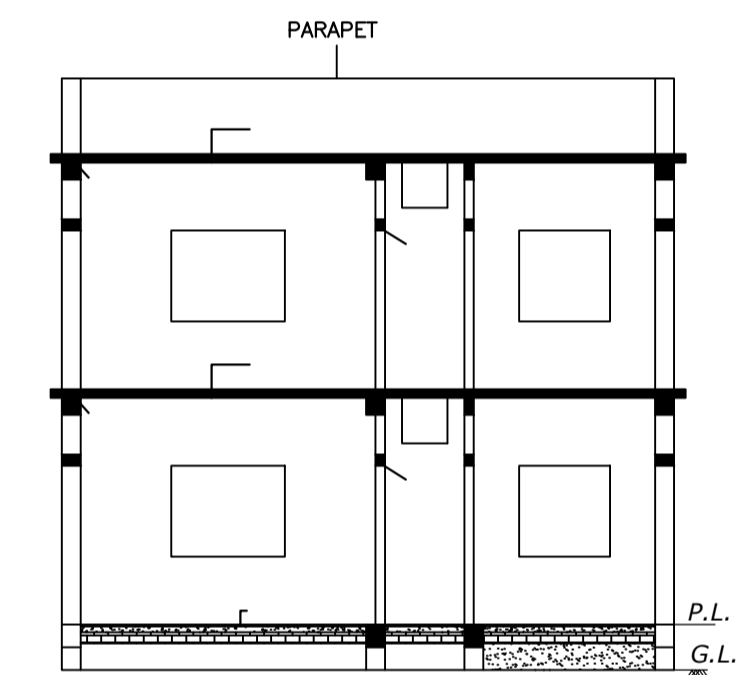

C/S AT A-A'

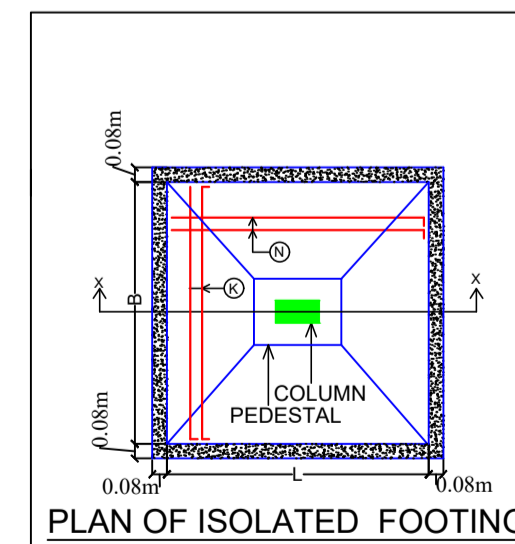
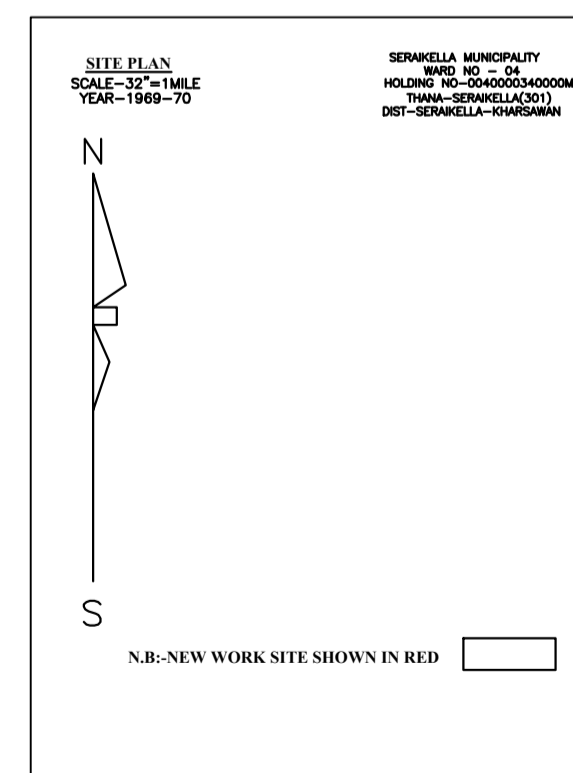

PLAN OF ISOLATED FOOTING

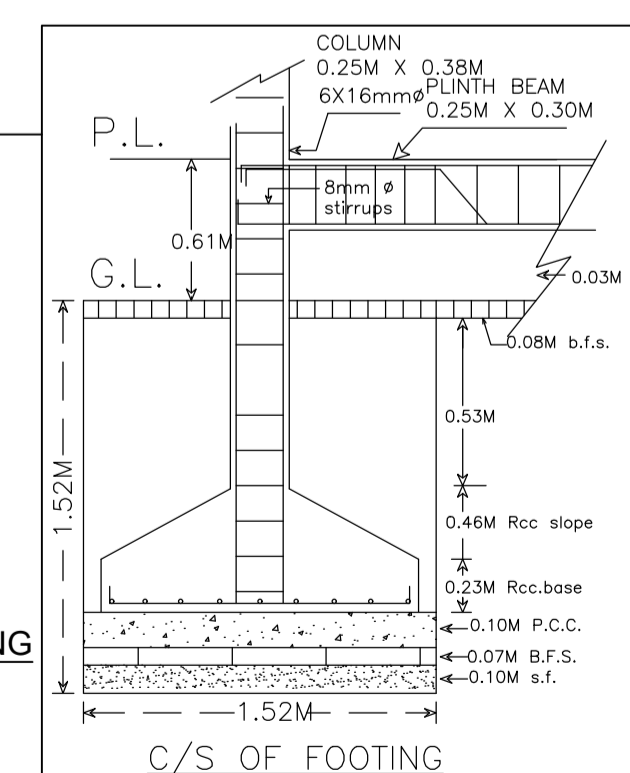

C/S OF FOOTING

LTP NAME AND SIGNATURE DURGA PRASAD DUBEY SNPC/ENG/0004/2017	STRUCTURAL ENG'S NAME AND SIGNATURE	BUILDER NAME AND SIGNATURE
--	-------------------------------------	----------------------------