

SCHEDULE OF DOOR:

BUILDING NAME	NAME	LENGTH	HEIGHT	NOS
A (A1)	D1	0.53	2.10	01
A (A1)	D2	0.75	2.10	04
A (A1)	D1	0.90	2.10	06
A (A1)	D	1.21	2.10	02

SCHEDULE OF WINDOW/VENTILATION:

BUILDING NAME	NAME	LENGTH	HEIGHT	NOS
A (A1)	V	0.67	1.20	03
A (A1)	W1	0.91	1.20	03
A (A1)	W	1.22	1.20	08

Proposal Basic Information

Proposal File No.	SNPC/BP/0004/W04/2019
Owner Name	BANDANA KABI
Khata No	101
Plot No	768
Village Name	Hansahudi
Use	Residential
SubUse	Other Residential Building

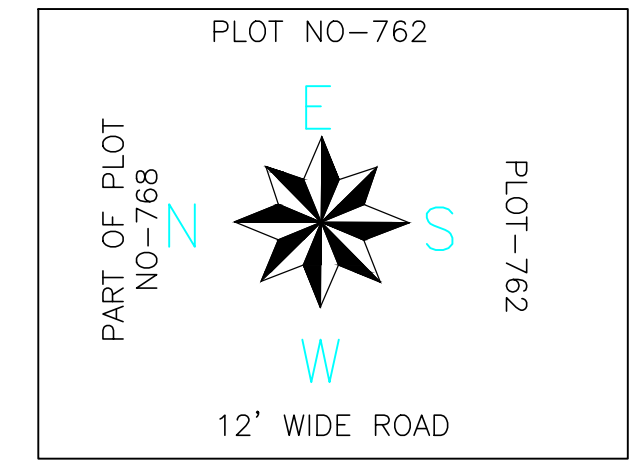

FAR & Tenement Details (Table 4c-1)

Building	No of Same Bldg	Total Built Up Area (Sq.mt.)	Proposed FAR Area (Sq.mt.)	Total FAR Area (Sq.mt.)	Total Consumed Additional FAR Area (Sq.mt.)	Tnmt (No.)
A (A1)	1	128.44	128.44	128.44	128.44	01
Grand Total :	1	128.44	128.44	128.44	128.44	01

Building USE/SUBUSE Details

Building Name	Building Use	Building SubUse	Building Structure
A (A1)	Residential	Other Residential Building	Non-Highrise

Buildingwise Floor FAR Details

Floor Name	Building Name A (A1)		Total	
	Proposed Built Up Area (Sq.mt.)	Proposed FAR Area (Sq.mt.)	Total Proposed Built Up Area (Sq.mt.)	Total FAR Area (Sq.mt.)
Ground Floor	128.44	128.44	128.44	128.44
Terrace Floor	0.00	0.00	0.00	0.00
Total	128.44	128.44	128.44	128.44

UnitBUA Table for Building :A (A1)

FLOOR	Name	UnitBUA Type	UnitBUA Area	Carpet Area	No. of Rooms	No. of Tenement
GROUND FLOOR PLAN	SPLIT a	FLAT	103.08	101.13	7	1
FLOOR PLAN	SPLIT a	FLAT	0.00	0.00	6	1
Total:	-	-	103.08	101.13	13	1

COLOR INDEX

PLOT BOUNDARY	Black
ABUTTING ROAD	Green
PROPOSED CONSTRUCTION	Red
COMMON PLOT	Yellow
ROAD WIDENING AREA	Blue
EXISTING (To be retained)	White
EXISTING (To be demolished)	Orange

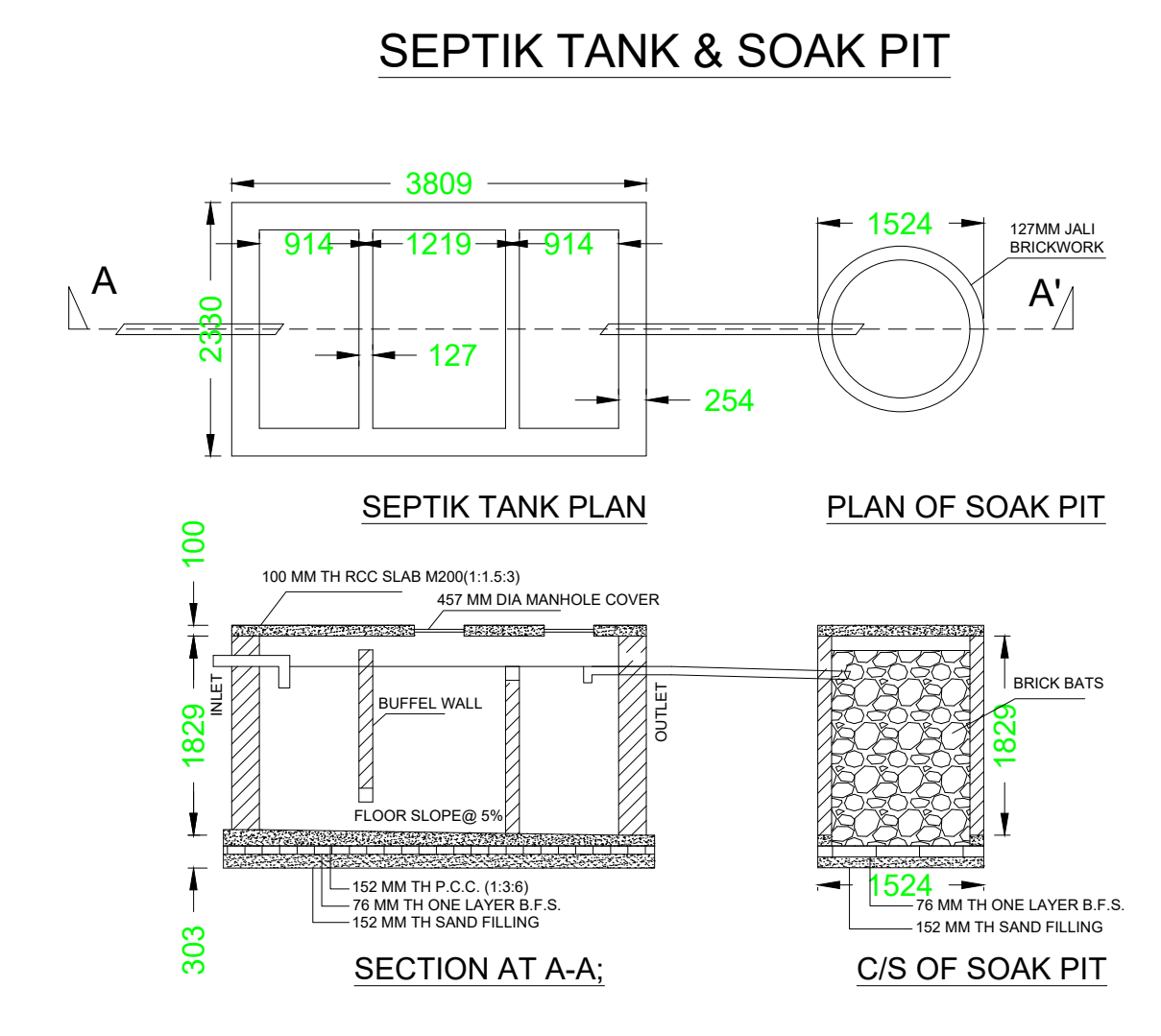
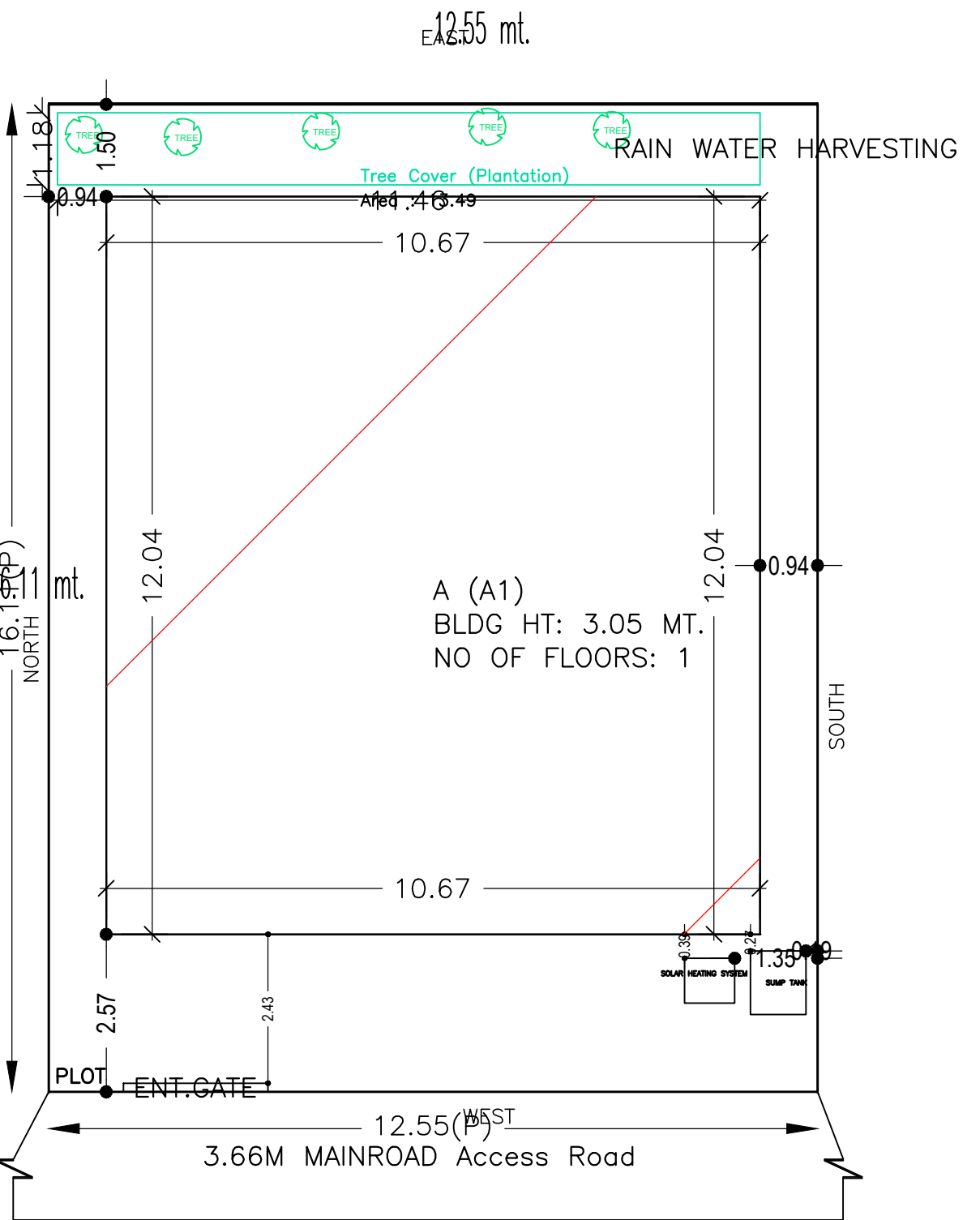
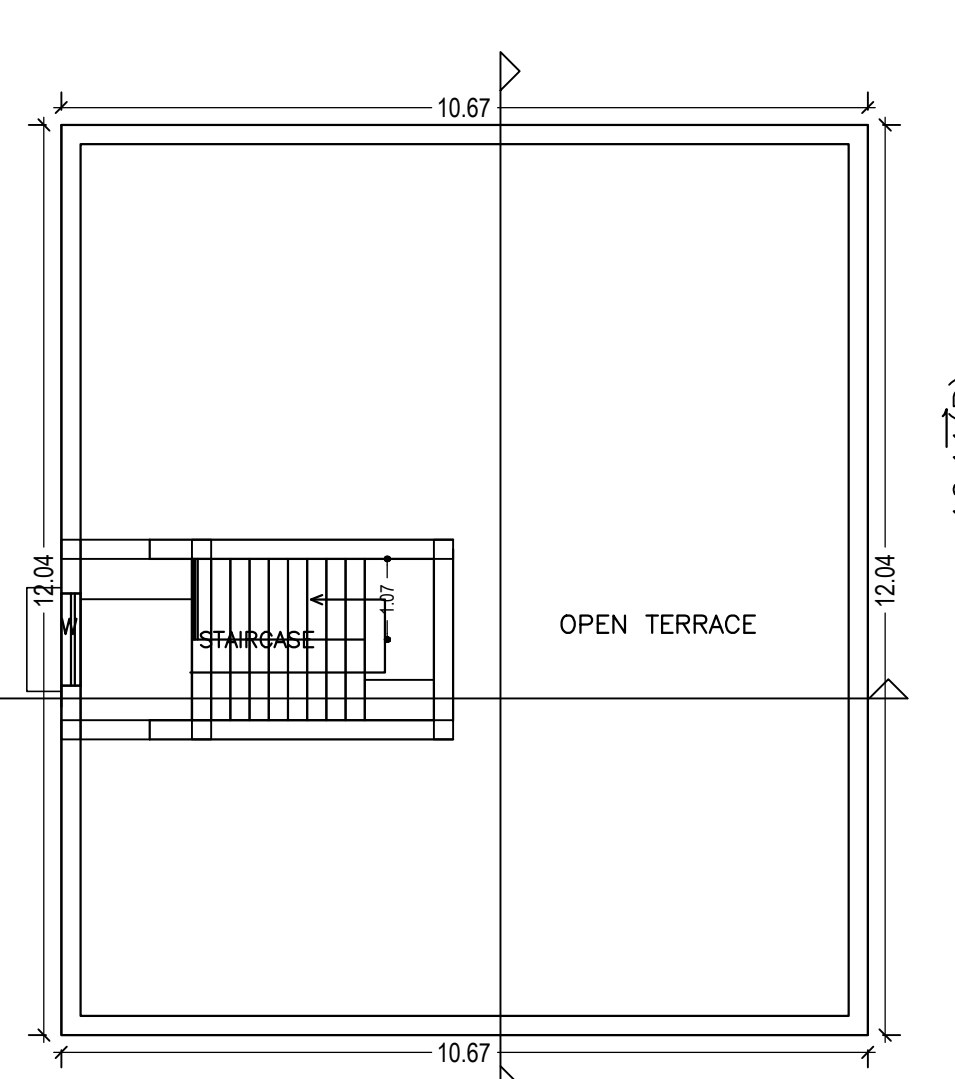
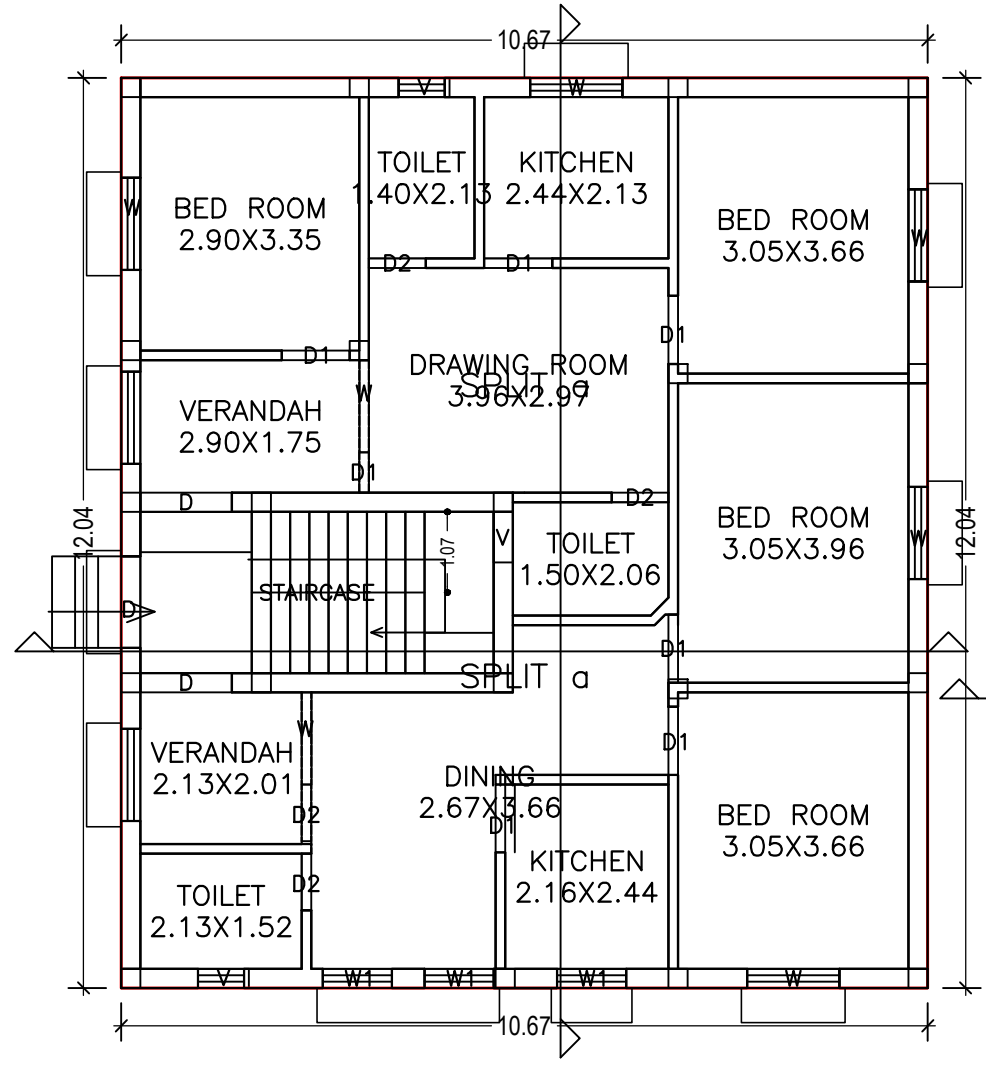
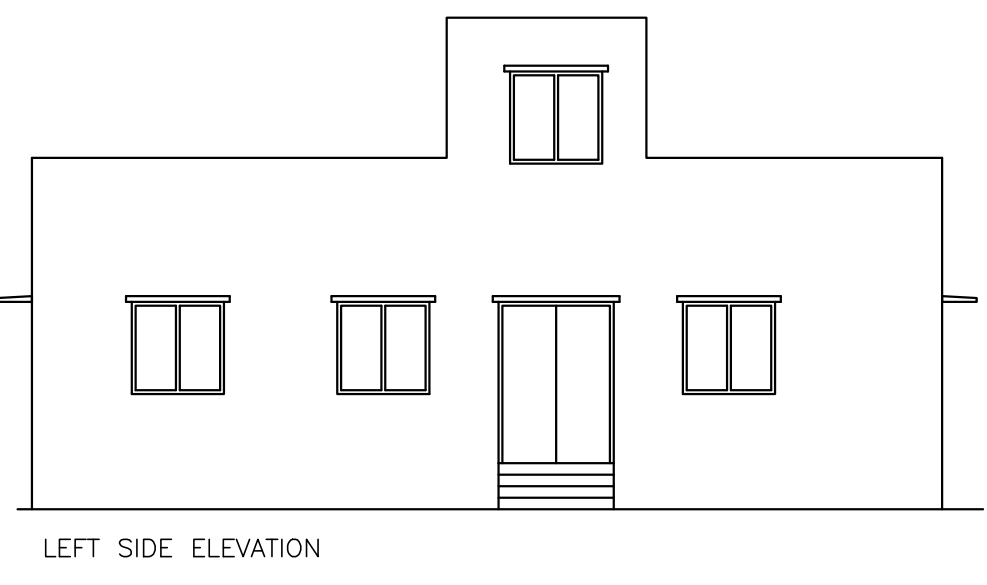
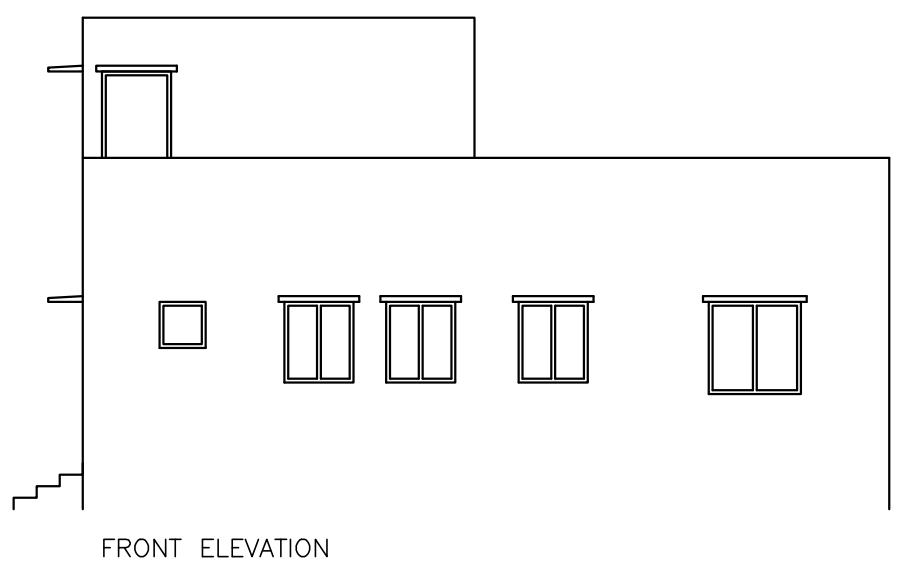
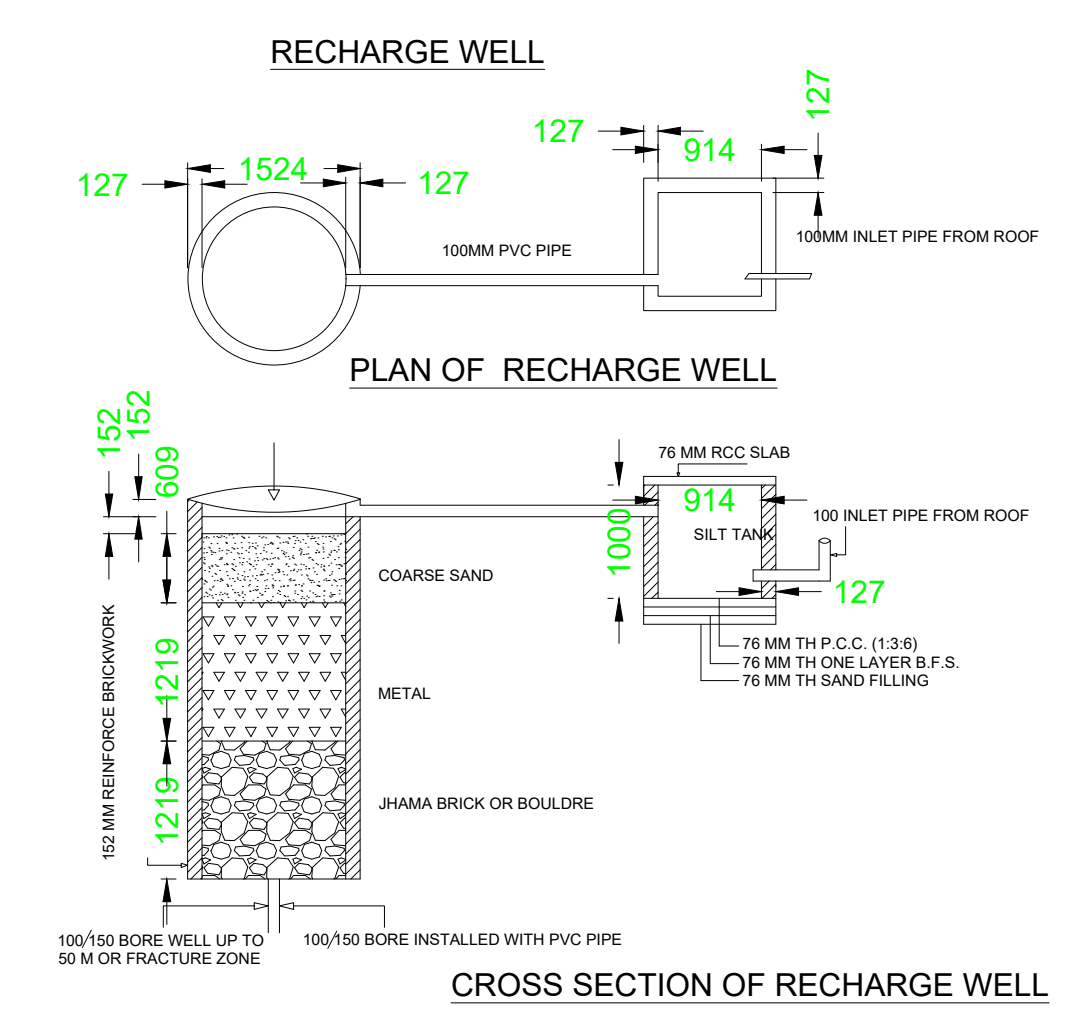
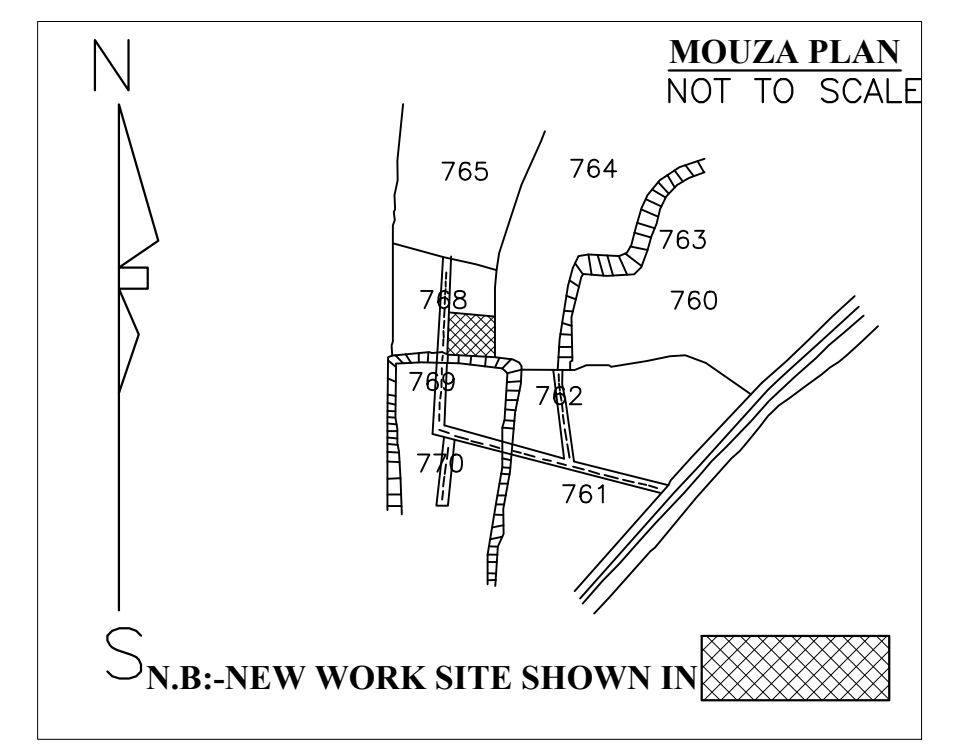
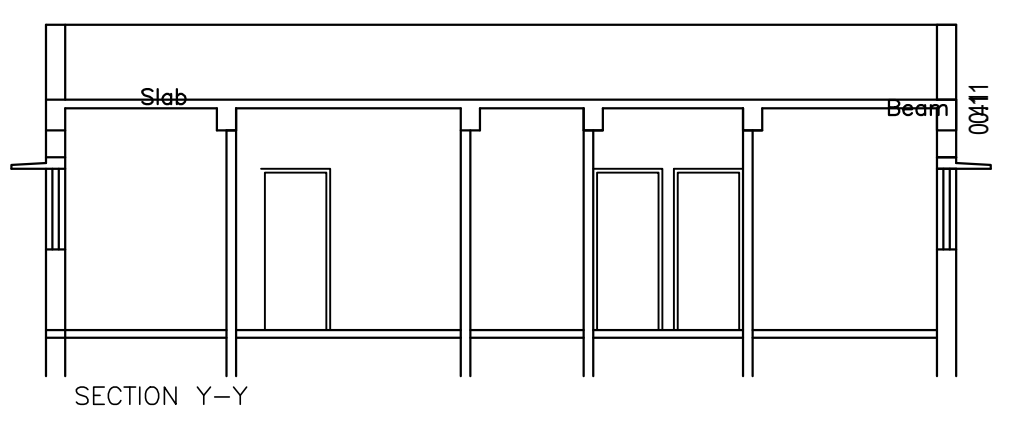
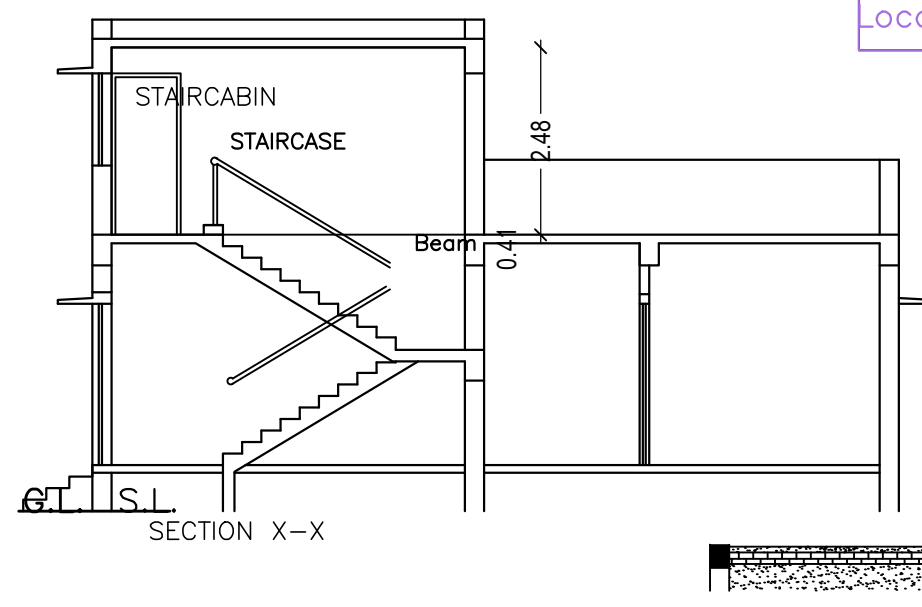

AREA STATEMENT

AREA OF PLOT (Minimum)	(A)	SQ.MT.	202.20
NET AREA OF PLOT(Gross Plot Area - Deduction from Gross Plot area)	(A-Deductions)		202.20
Deduction for Balance Plot Area(from Gross Plot Area)			13.49
Balance AREA OF PLOT(Net Plot Area - Recreational/Amenity space)	(A-Deductions)		188.71
PLOT AREA FOR COVERAGE(Net Plot Area)	(A-Deductions)		202.20
Plot Area for FAR (Net Plot Area + Road/Widening Area)	(A-Deductions)		202.20

COVERAGE CHECK

Permissible Coverage area (70.00 %)	141.54
Proposed Coverage Area (63.52 %)	128.44
Total Prop. Coverage Area (63.52 %)	128.44
Balance coverage area (6.48 %)	13.10

FAR CHECK

Perm. FAR Area (1.50)	303.30
Total Perm. FAR area	303.30
Residential FAR	128.44
Proposed FAR Area	128.44
Total Proposed FAR Area	128.44
Consumed FAR (Factor)	0.64
Balance FAR Area	174.86

BUILT UP AREA CHECK

Total Proposed BuiltUp Area	128.44
-----------------------------	--------

ARCHITECT (Regd) DURGA PRASAD DUBEY

ENGINEER (Regd)

SUPERVISOR (Regd)

OWNER (Regd) BANDANA KABI

DEVELOPMENT AUTHORITY LOCAL BODY

LTP NAME AND SIGNATURE	STRUCTURAL ENG'S NAME AND SIGNATURE	BUILDER NAME AND SIGNATURE	DIGITAL SIGNATURE
DURGA PRASAD DUBEY SNPC/ENG/0004/2017			