

C/S AT A-A'

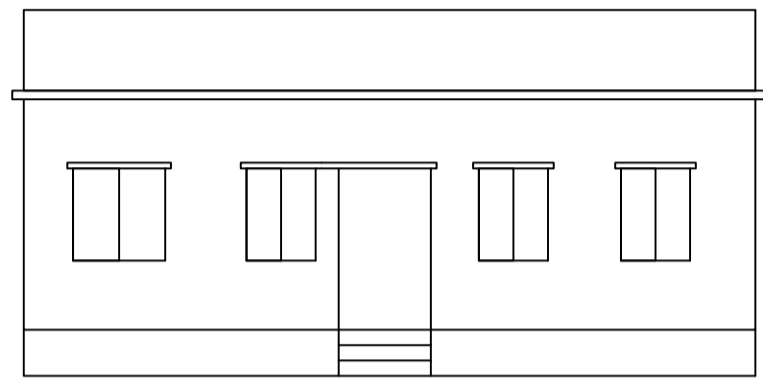

FRONT ELEVATION

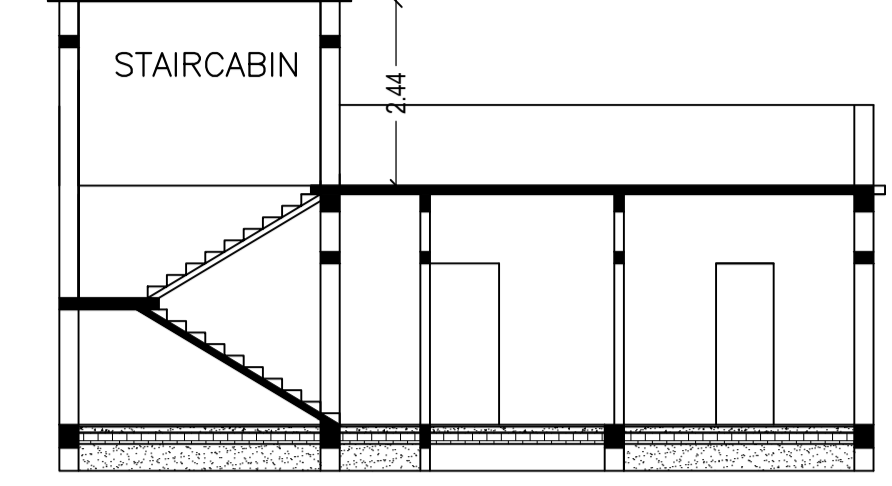

C/S AT X-X'

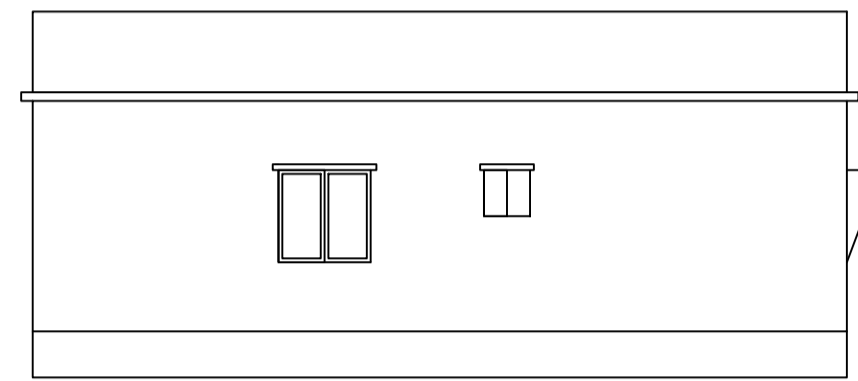

RIGHT SIDE ELEVATION

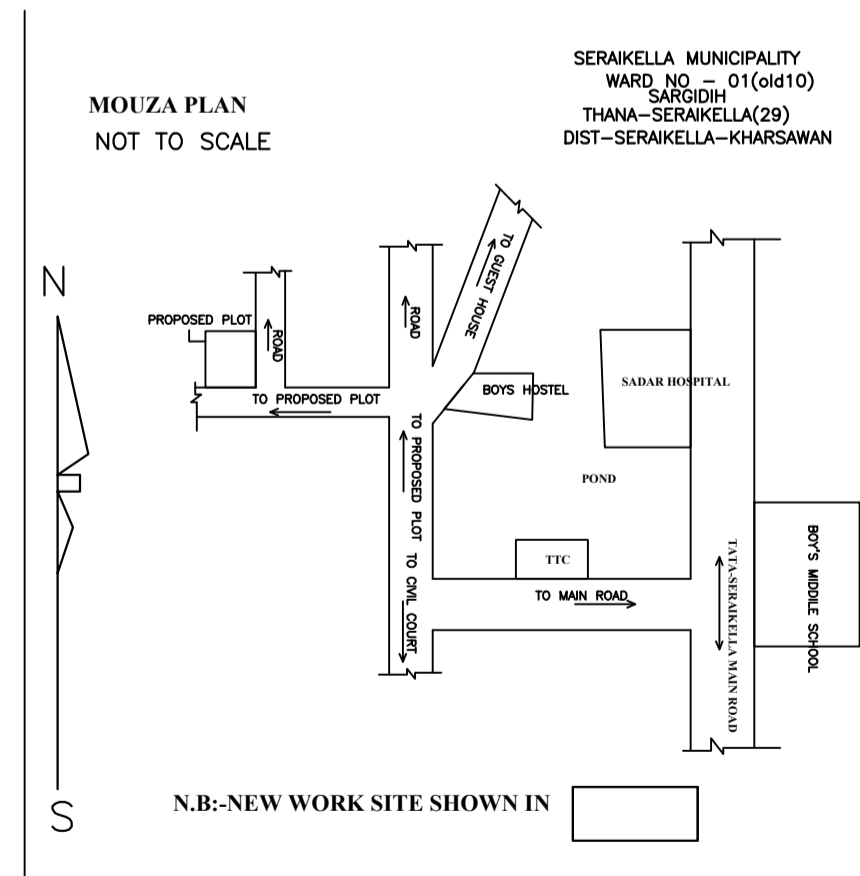
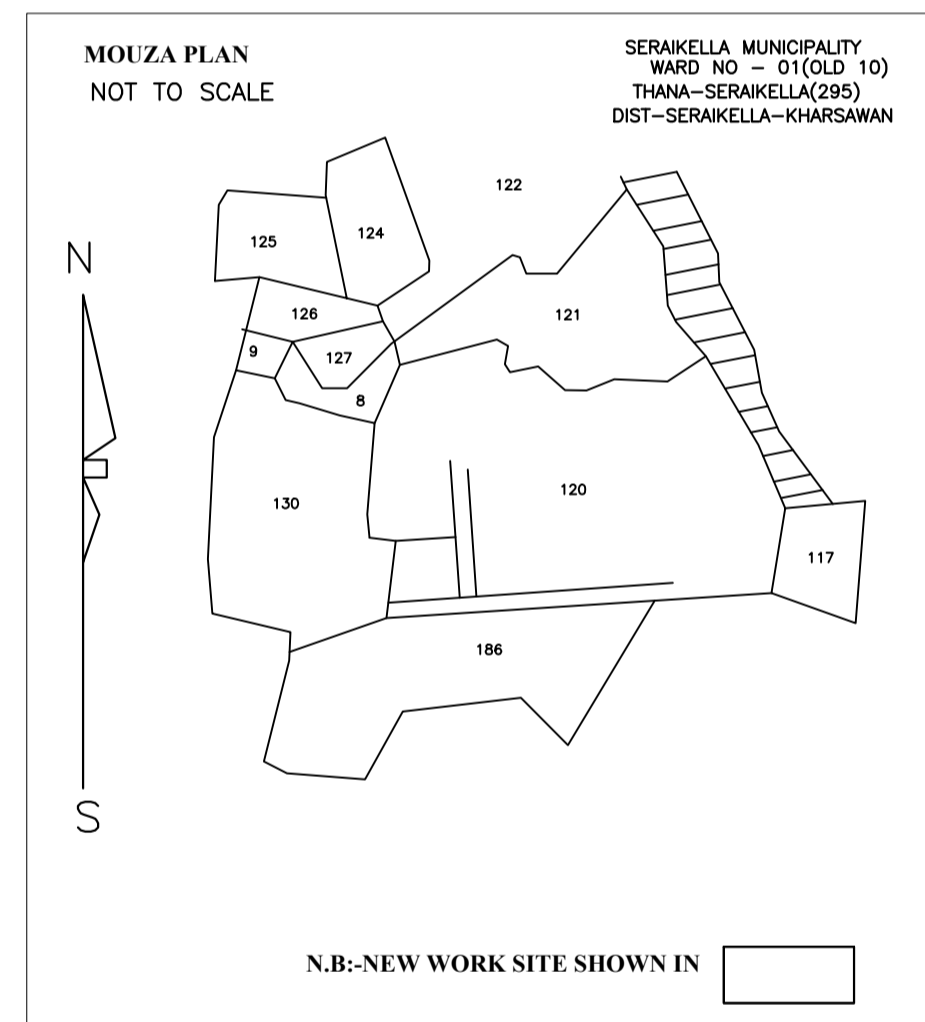
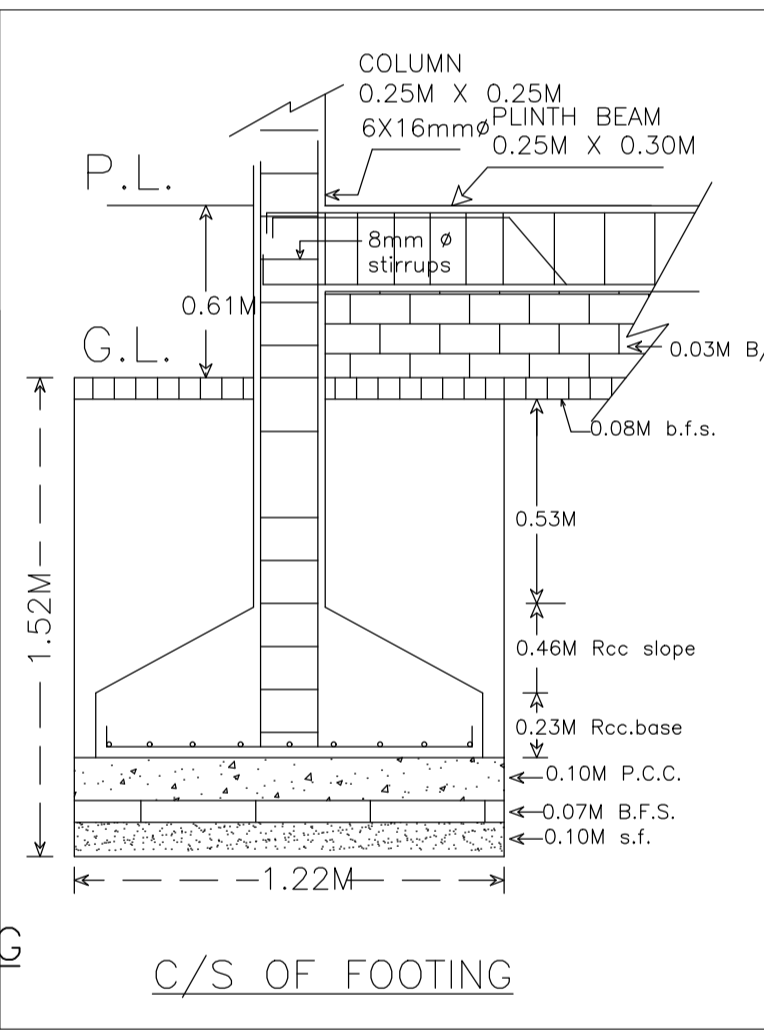
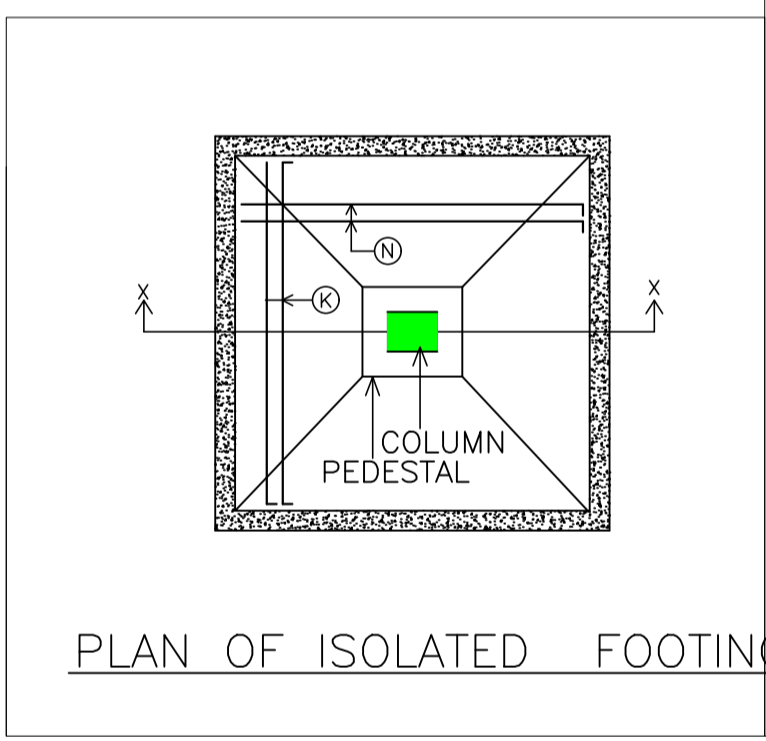
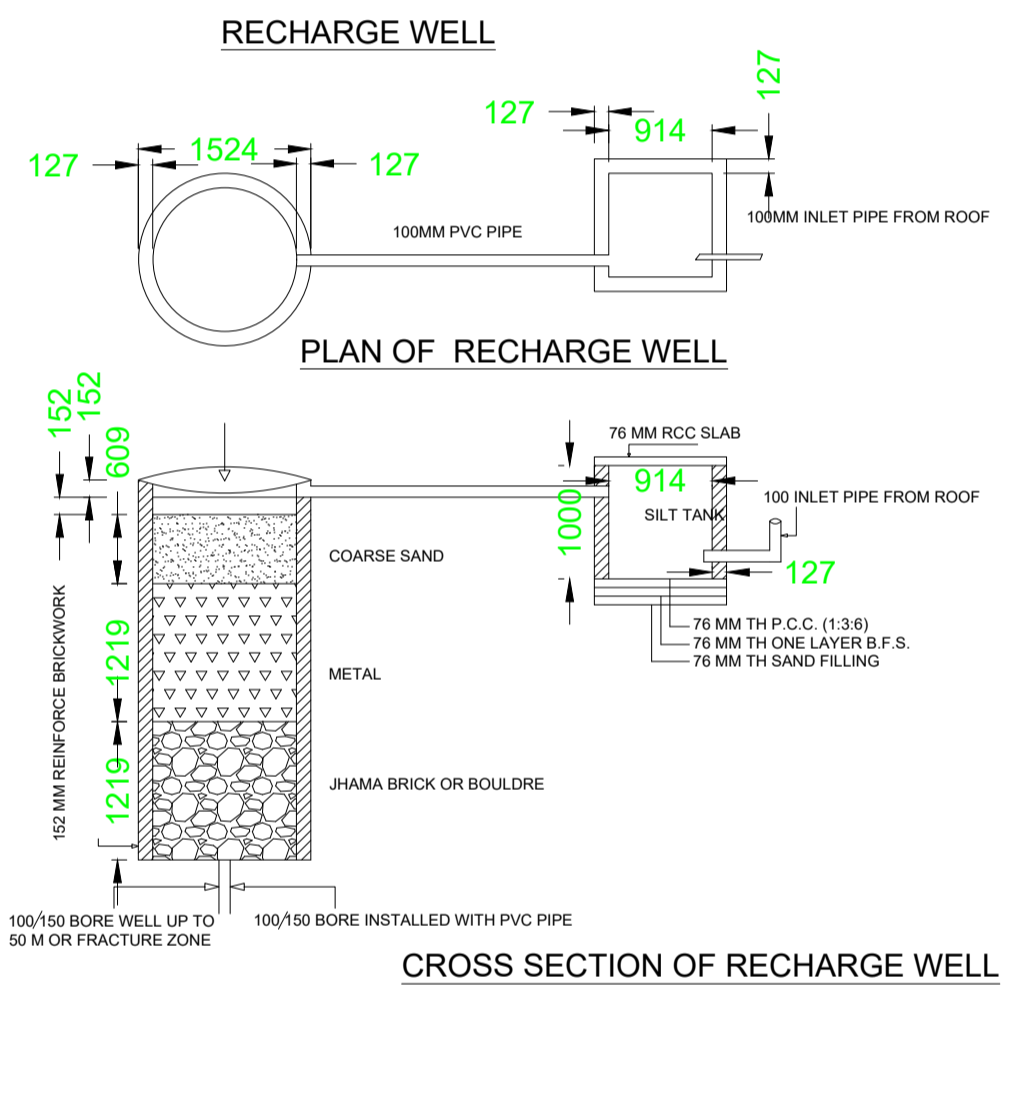

AREA STATEMENT SARAIKELLA NAGAR PANCHAYAT	VERSION NO.: 1.0.39	
PROJECT DETAIL:	VERSION DATE: 29/04/2019	
Region: JHARKHAND URBAN LOCAL BODIES	Plot Use: Residential	
District: SERAIKELLA	Plot SubUse: Other Residential Building	
Authority: SARAIKELLA NAGAR PANCHAYAT	PlotNearbyReligiousStructure: NA	
Inward_No: SNPC/BP/0032/W01/2019	Plot/SubPlot No: 115	
Application Type: General Proposal	North: Plot No. - 120	
Project Type: Building Permission	South: Road Width - 4.88	
Nature of Development: New	East: Road Width - 4.88	
Location of Development Area: Old Area	West: Plot No. - 130	
AREA DETAILS:		
AREA OF PLOT (Minimum)	(A)	SQ.MT.
NET AREA OF PLOT(Gross Plot Area - Deduction from Gross Plot area)	(A-Deductions)	204.35
Deduction from Balance Plot Area(from Gross Plot Area)		
Common Plot		26.44
Total		26.44
BALANCE AREA OF PLOT(Net Plot Area - Recreational/Amenity space)	(A-Deductions)	177.91
PLOT AREA FOR COVERAGE(Net Plot Area)	(A-Deductions)	204.35
Plot Area for FAR (Net Plot Area + Road Widening Area)	(A-Deductions)	204.35
COVERAGE CHECK		
Permissible Coverage area (70.00 %)		143.04
Proposed Coverage Area (51.00 %)		104.22
Total Prop. Coverage Area (51 %)		104.22
Balance coverage area (19.00 %)		38.82
FAR CHECK		
Perm. FAR Area (1.80)		367.83
Total Perm. FAR area		367.83
Residential FAR		104.22
Proposed FAR Area		104.22
Total Proposed FAR Area		104.22
Consumed FAR (Factor)		0.51
Balance FAR Area		263.61
BUILT UP AREA CHECK		
Total Proposed BuiltUp Area		104.22
ARCHITECT (Regd)		DURGA PRASAD DUBEY
ENGINEER (Regd)		
SUPERVISOR (Regd)		
OWNER (Regd)		BABITA KANDEYANG
DEVELOPMENT AUTHORITY		LOCAL BODY

COLOR INDEX	
PLOT BOUNDARY	Black
ABUTTING ROAD	Green
PROPOSED CONSTRUCTION	Red
COMMON PLOT	Yellow
ROAD WIDENING AREA	Blue
EXISTING (To be retained)	Light Blue
EXISTING (To be demolished)	Light Yellow

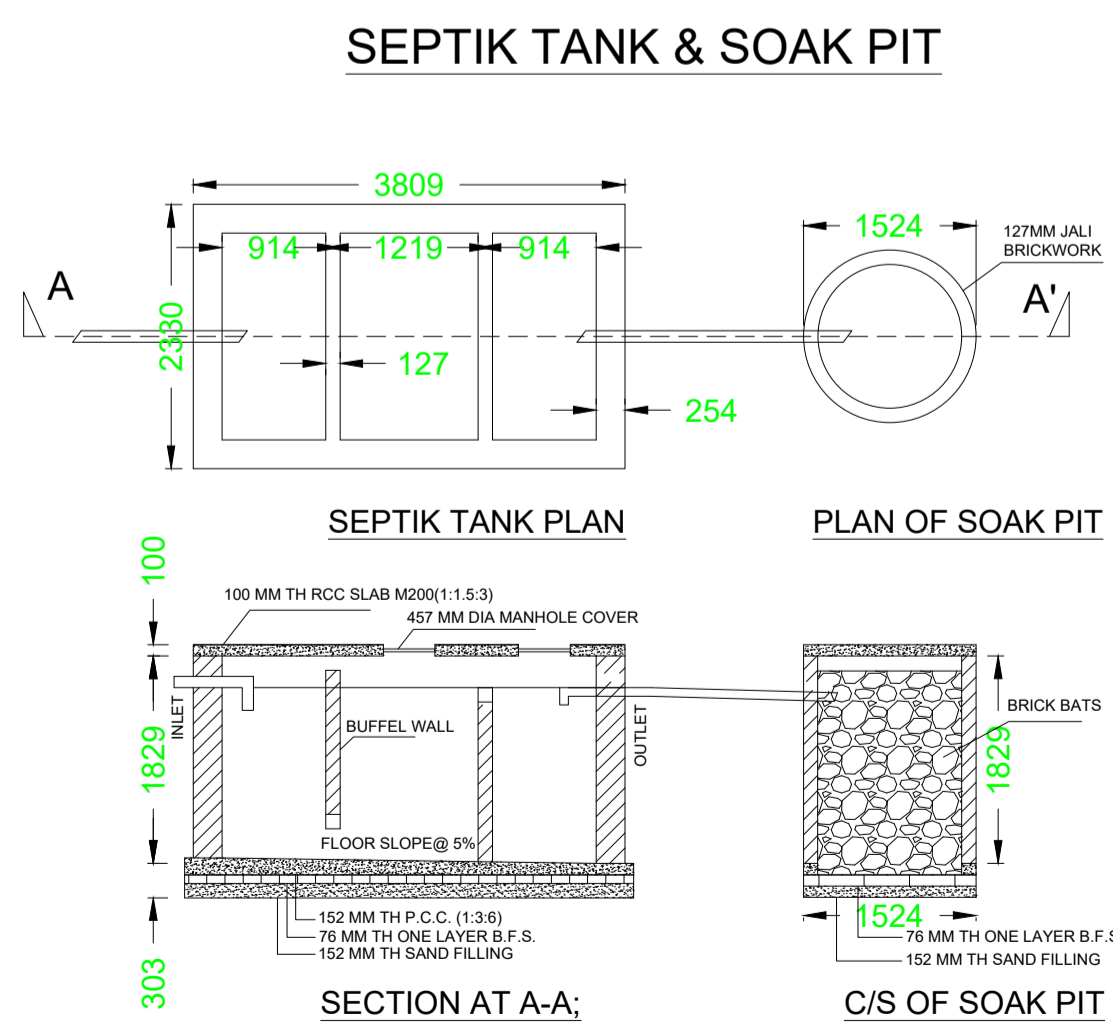

SCHEDULE OF DOOR:

BUILDING NAME	NAME	LENGTH	HEIGHT	NOS
A (RESIDENTIAL)	D2	0.76	2.10	04
A (RESIDENTIAL)	D1	0.90	2.10	04
A (RESIDENTIAL)	D	1.20	2.10	02

SCHEDULE OF WINDOW/VENTILATION:

BUILDING NAME	NAME	LENGTH	HEIGHT	NOS
A (RESIDENTIAL)	V	0.61	0.61	03
A (RESIDENTIAL)	W1	0.90	1.20	04
A (RESIDENTIAL)	W	1.20	1.20	04

UnitBUA Table for Building :A (RESIDENTIAL)

FLOOR	Name	UnitBUA Type	UnitBUA Area	Carpet Area	No. of Rooms	No. of Tenement
GROUND FLOOR PLAN	SPLIT A	FLAT	85.84	79.89	9	1
Total:	-	-	85.84	79.89	9	1

Building :A (RESIDENTIAL)

Floor Name	Total Built Up Area (Sq.mt.)	Proposed FAR Area (Sq.mt.) Resi.	Total FAR Area (Sq.mt.)	Total Consumed Additional FAR Area (Sq.mt.)	Tnmt (No.)
Ground Floor	104.22	104.22	104.22	104.22	01
Terrace Floor	0.00	0.00	0.00	0.00	00
Total :	104.22	104.22	104.22	104.22	01
Total Number of Same Buildings :	1				
Total :	104.22	104.22	104.22	104.22	01

Buildingwise Floor FAR Details

Floor Name	Building Name		Total	
	A (RESIDENTIAL)	Total Proposed Built Up Area (Sq.mt.)	Total Proposed Built Up Area (Sq.mt.)	Total FAR Area (Sq.mt.)
Ground Floor	104.22	104.22	104.22	104.22
Terrace Floor	0.00	0.00	0.00	0.00
Total :	104.22	104.22	104.22	104.22

FAR & Tenement Details (Table 4c-1)

Building	No. of Same Bldg	Total Built Up Area (Sq.mt.)	Proposed FAR Area (Sq.mt.) Resi.	Total FAR Area (Sq.mt.)	Total Consumed Additional FAR Area (Sq.mt.)	Tnmt (No.)
A (RESIDENTIAL)	1	104.22	104.22	104.22	104.22	01
Grand Total :	1	104.22	104.22	104.22	104.22	01

Building USE/SUBUSE Details

Building Name	Building Use	Building SubUse	Building Structure
A (RESIDENTIAL)	Residential	Other Residential Building	Non-Highrise

LTP NAME AND SIGNATURE	STRUCTURAL ENG'S NAME AND SIGNATURE	BUILDER NAME AND SIGNATURE	DIGITAL SIGNATURE
DURGA PRASAD DUBEY SNPC/ENG/0004/2017			