

Proposal Basic Information

Proposal File No.	SNPC/BP/0002/W03/2020/REV1
Owner Name	SMT. SUBHASHINI SAHU
Khata No	113,147
Plot No	487,488/A
Village Name	Bazar Sai
Use	Residential
SubUse	ResiComm Bldg

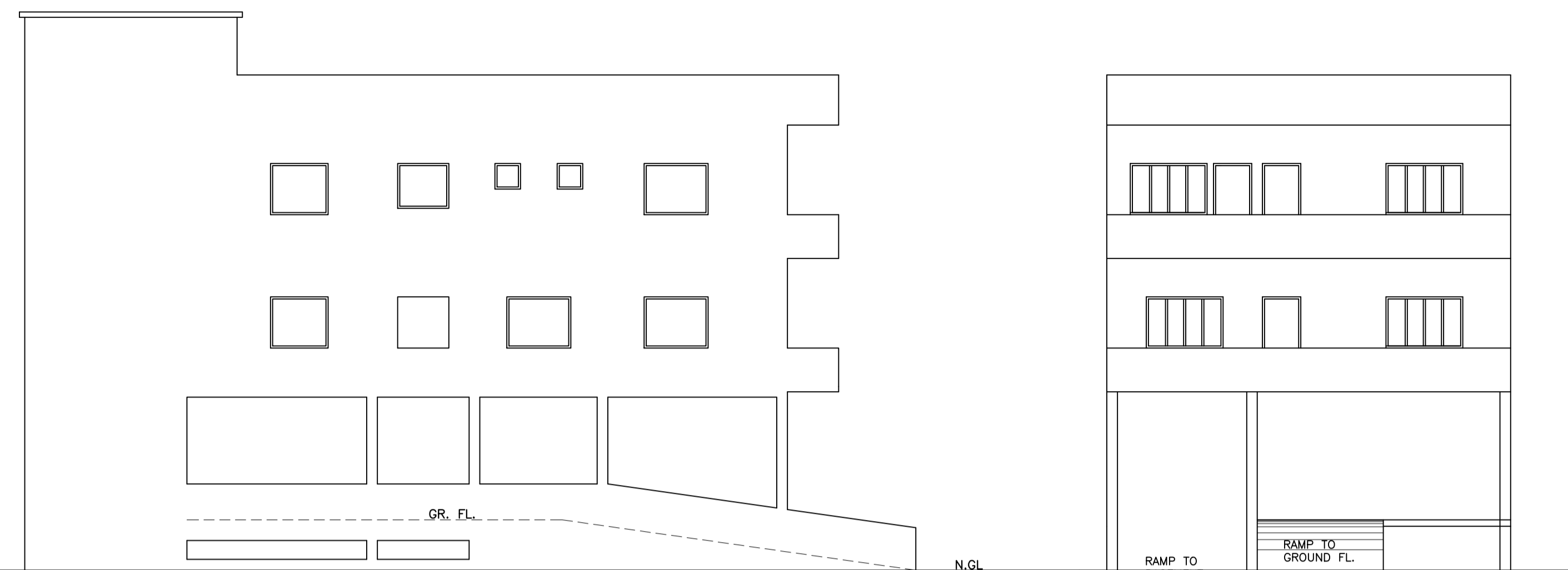

LEFT SIDE ELEVATION

FRONT ELEVATION

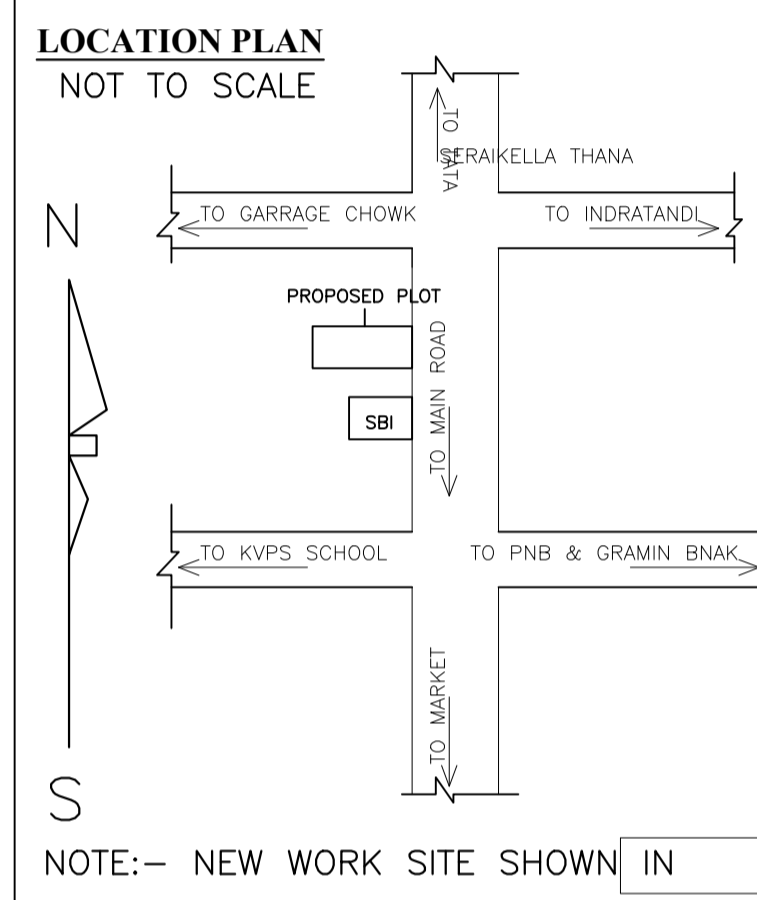
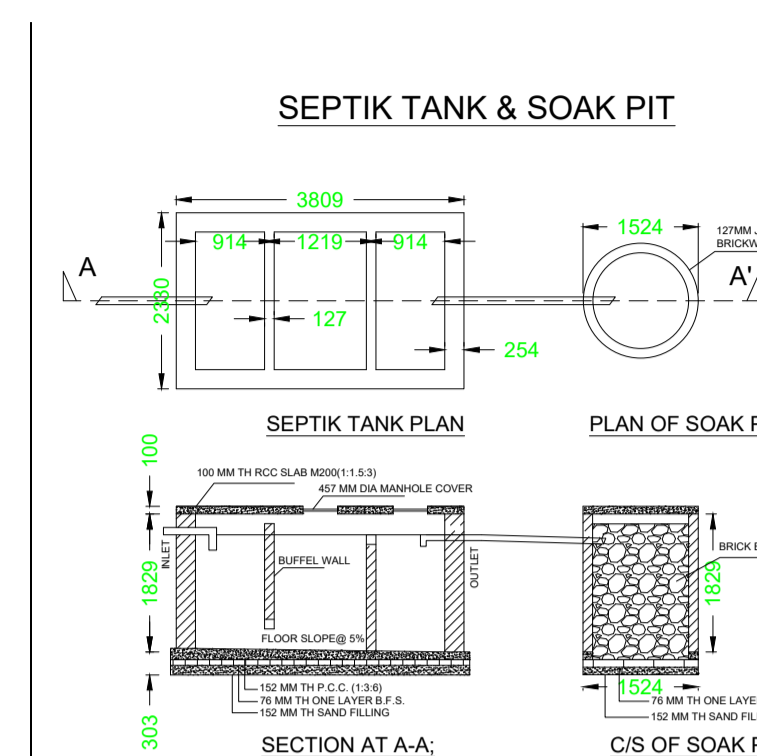

SCHEDULE OF DOOR:

BUILDING NAME	NAME	LENGTH	HEIGHT	NOS
A (RESIDENTIAL)	D2	0.75	2.10	04
A (RESIDENTIAL)	D2	0.76	2.10	01
A (RESIDENTIAL)	D	0.90	2.10	03
A (RESIDENTIAL)	D1	0.91	2.10	04
A (RESIDENTIAL)	D	0.93	2.10	02
A (RESIDENTIAL)	D1	1.05	2.10	05

SCHEDULE OF WINDOW/VENTILATION:

BUILDING NAME	NAME	LENGTH	HEIGHT	NOS
A (RESIDENTIAL)	V	0.60	0.75	01
A (RESIDENTIAL)	V	0.60	0.90	04
A (RESIDENTIAL)	W2	1.20	1.20	01
A (RESIDENTIAL)	W	1.50	1.20	01
A (RESIDENTIAL)	W1	1.50	1.20	13
A (RESIDENTIAL)	W	1.80	1.20	02
A (RESIDENTIAL)	W	1.83	1.20	02

Balcony Calculations Table

FLOOR	SIZE	AREA	TOTAL AREA
SECOND FLOOR PLAN	1.20 X 3.45 X 1 X 1	4.14	10.19
	1.20 X 5.04 X 1 X 1	6.05	
Total	-	-	10.19

UnitBUA Table for Building :A (RESIDENTIAL)

FLOOR	Name	UnitBUA Type	UnitBUA Area	Carpet Area	No. of Rooms	No. of Tenement
FIRST FLOOR PLAN	SPLIT A	FLAT	232.75	227.53	4	1
SECOND FLOOR PLAN	SPLIT A	FLAT	0.00	0.00	7	0
Total:	-	-	232.75	227.53	18	1

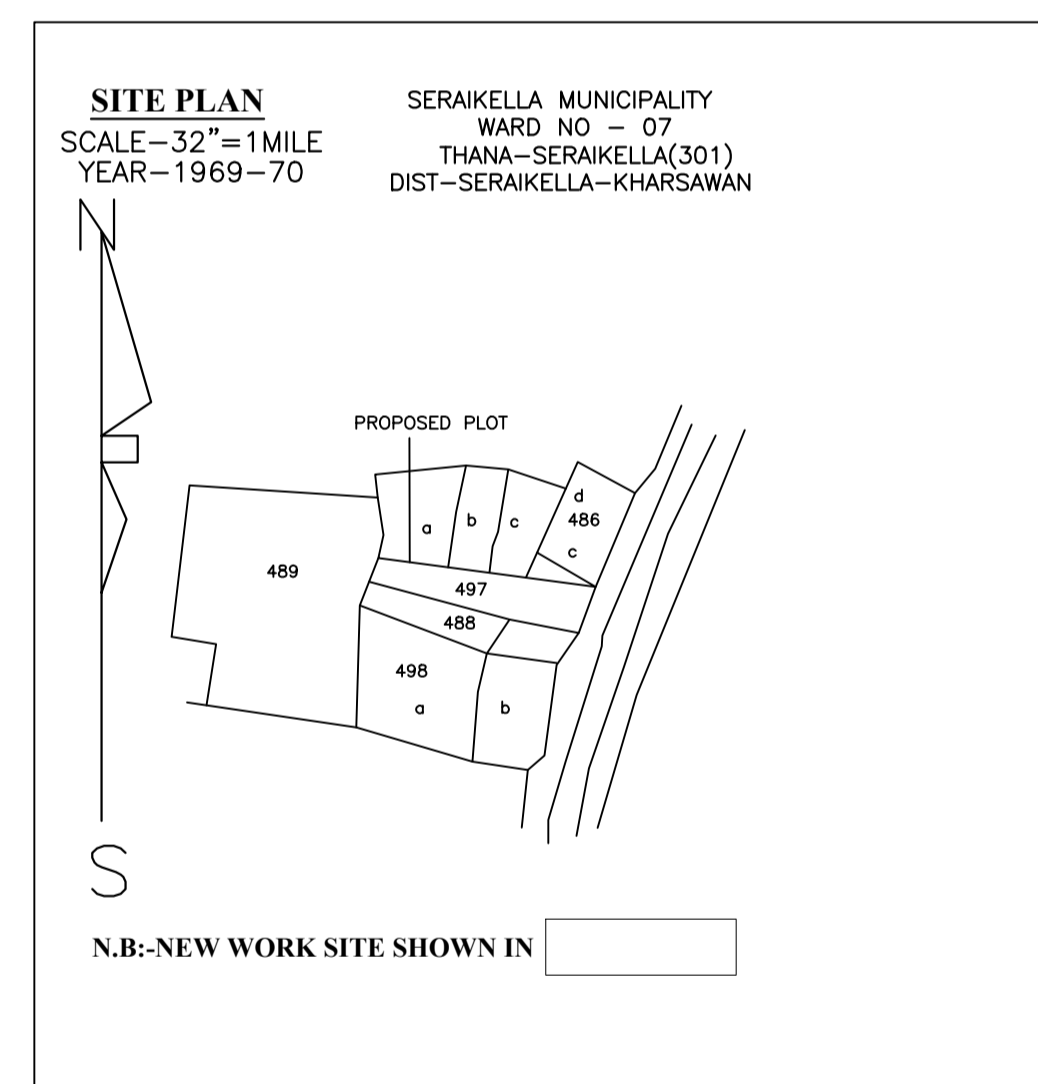
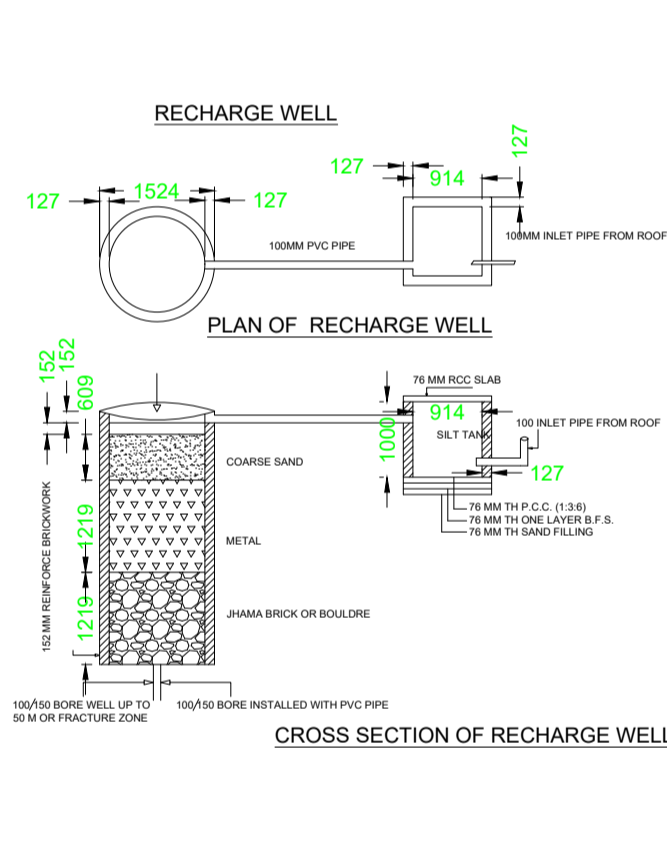

LTP NAME AND SIGNATURE DURGA PRASAD DUBEY SNPC/ENG/0004/2017	STRUCTURAL ENG'S NAME AND SIGNATURE	BUILDER NAME AND SIGNATURE
--	-------------------------------------	----------------------------

Name : RAJENDRA PRASAD GUPTA
Designation : Executive Engineer
Organization : KATRAJI MUNICIPAL COUNCIL

Proposal Basic Information	
Proposal File No.	SNPC/BP/0002/W03/2020/REV1
Owner Name	SMT. SUBHASHINI SAHU
Khata No	113,147
Plot No	487,488/A
Village Name	Bazar Sai
Use	Residential
SubUse	ResiComm Bldg

LTP NAME AND SIGNATURE	STRUCTURAL ENG'S NAME AND SIGNATURE	BUILDER NAME AND SIGNATURE
DURGA PRASAD DUBEY SNPC/ENG/0004/2017		

Name : RAJENDRA PRASAD GUPTA
Designation : Executive Engineer
Organization : KATPALI MUNICIPAL COUNCIL